



x2



1.5h



für Mamas & Papas entschieden haben.

Seit über 30 Jahren entwickeln wir mit großem Engagement für Eltern in aller Welt Produkte, die für Qualität, Individualität und Stil stehen. Die erste Inspiration gaben uns unsere Töchter, die mittlerweile erwachsen sind, selbst Kinder haben und uns nun dabei helfen, die Mütter und Väter ihrer Generation mit unserer Begeisterung für Babyprodukte anzustecken. Wir hoffen, dass es Ihnen Spaß machen wird, sich unsere neue Kollektion anzusehen, und heißen Sie herzlich willkommen in unserer Welt.

Wir haben es uns zur Aufgabe gemacht, Produkte auf höchstem Niveau zu entwerfen, die Ihre Familie genießen kann. Daher freuen wir uns immer über Ihr Feedback oder Ihre Kommentare.

Die Mamas & Papas-Familie.

Grazie per aver scelto Mamas & Papas.

Da oltre 30 anni lavoriamo per creare un mondo di qualità, unicità e stile per i genitori di tutto il mondo. All'inizio abbiamo tratto ispirazione dalle nostre figlie; adesso che sono cresciute e hanno a loro volta dei figli, ci aiutano a far conoscere alla loro generazione di mamme e papà la nostra passione nel vivere l'esperienza di genitori. Ci auguriamo che apprezzerete la nostra nuova collezione e vi diamo un caloroso benvenuto nel nostro mondo

Il nostro impegno è quello di progettare e realizzare prodotti rispondenti agli standard più elevati per la vostra famiglia e saremo lieti di ricevere suggerimenti o commenti da parte vostra.

La famiglia di Mamas & Papas.

Hartelijk dank dat u voor een product van Mamas & Papas heeft gekozen.

Al meer dan 30 jaar zetten wij ons in om een wereld van kwaliteit, individualiteit en stijl te scheppen voor ouders verspreid over de hele aardbol. In het begin werden we geïnspireerd door onze eigen dochters. Nu die volwassen zijn en zelf kinderen hebben, helpen zij ons onze passie voor ouderschap te delen met vaders en moeders van hun eigen generatie. We hopen dat u onze nieuwe collectie met plezier zult verkennen en heten u van harte welkom in onze wereld.

Wij hopen dat u met uw gezin van onze producten zult genieten en mocht u feedback willen geven of andere opmerkingen hebben, dan horen we graag van u.

De Mamas & Papas Familie.



EN **IMPORTANT!**
RETAIN FOR FUTURE REFERENCE:
READ CAREFULLY





















ES **¡IMPORTANTE!**
LEA ESTAS INSTRUCCIONES DETENIDAMENTE Y
GUÁRDELAS PARA FUTURA REFERENCIA

FR **IMPORTANT !**
VEUILLEZ LIRE CES CONSIGNES AVEC ATTENTION
ET LES CONSERVER POUR VOUS Y REPORTER
ULTÉRIEUREMENT

D **ACHTUNG!**
BITTE LESEN SIE SICH DIESE ANWEISUNGEN
SORGFÄLTIG DURCH UND BEWAHREN SIE SIE FÜR
ZUKÜNFTIGE VERWENDUNG AUF

IT **IMPORTANTE!**
LEGGERE ATTENTAMENTE QUESTE ISTRUZIONI E
CONSERVARLE COME RIFERIMENTO FUTURO

NL **BELANGRIJK!**
BEWAAR VOOR TOEKOMSTIGE REFERENTIE:
LEES DIT ZORGVULDIG DOOR

-  1
-  1
-  2
-  7 x4
-  10 x3
-  11 x3
-  13 x3
-  14
-  15
-  18
- 
-  2
-  3
-  4
-  5 x3
-  6
-  8 x2
-  9
-  12 x3
-  16
-  17

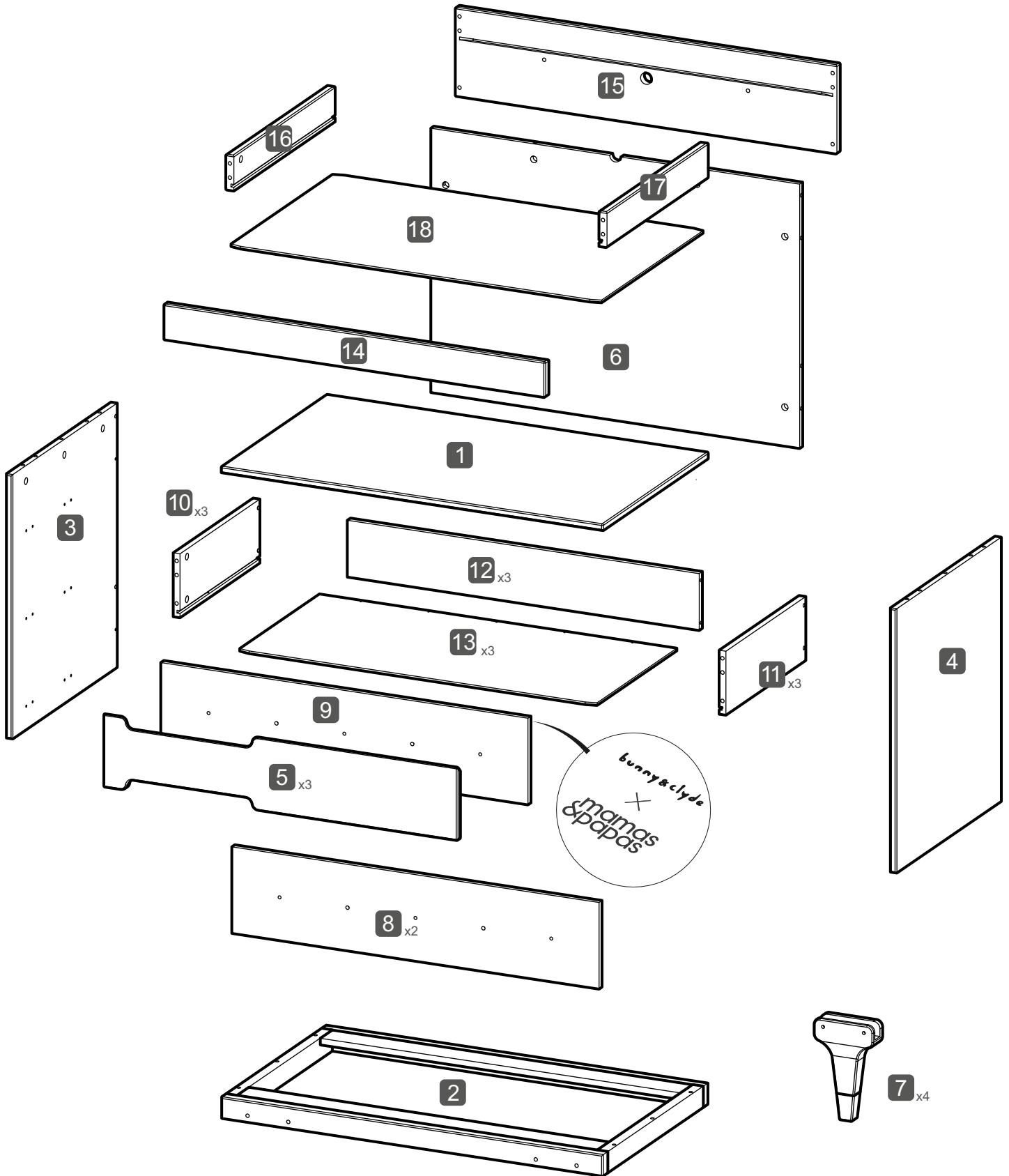

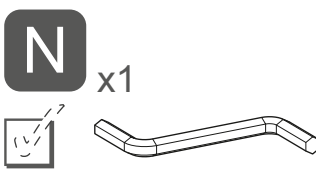
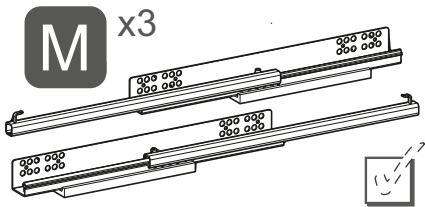
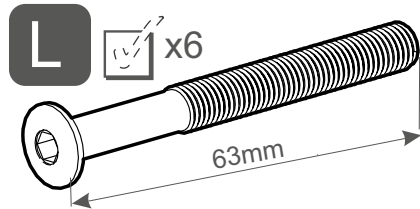
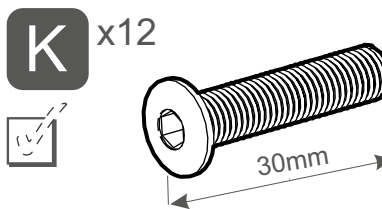
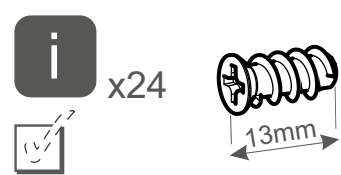
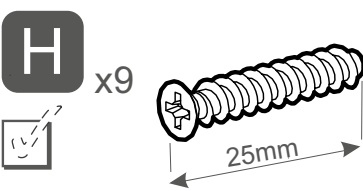
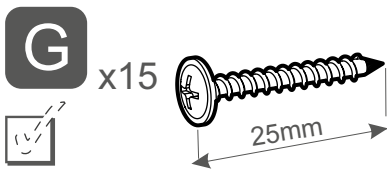
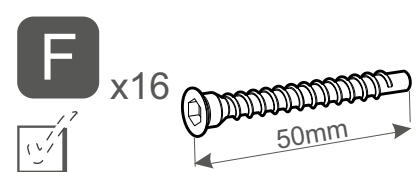
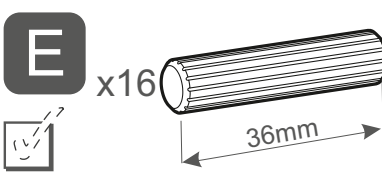
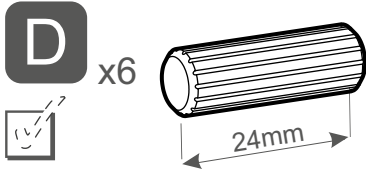
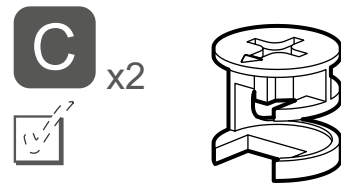
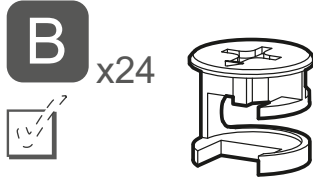
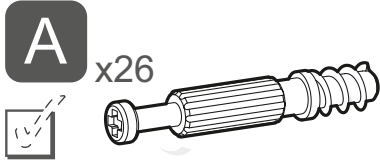
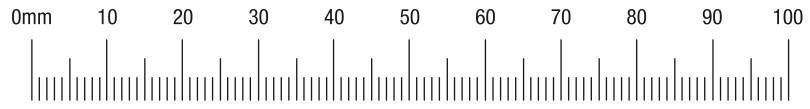

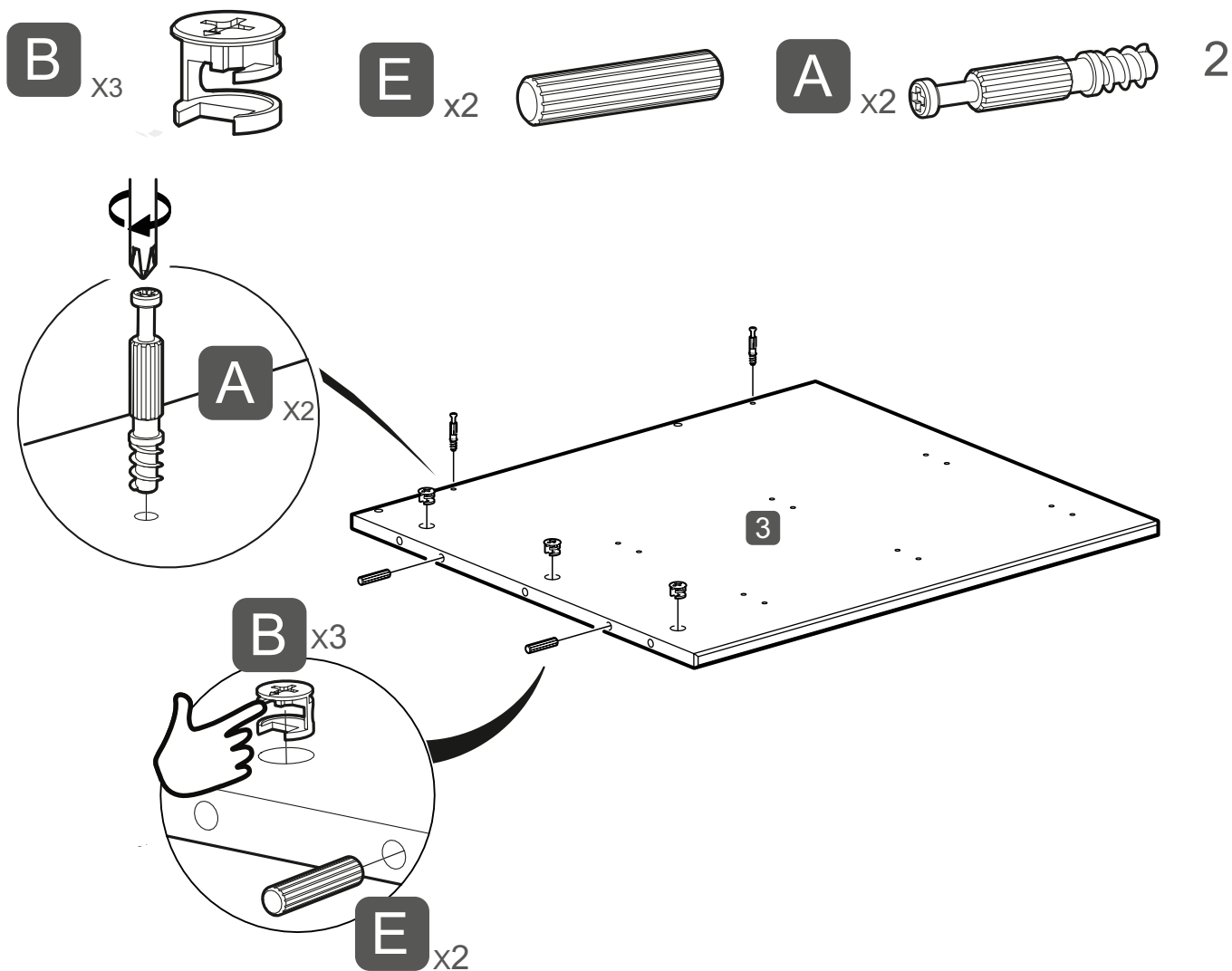
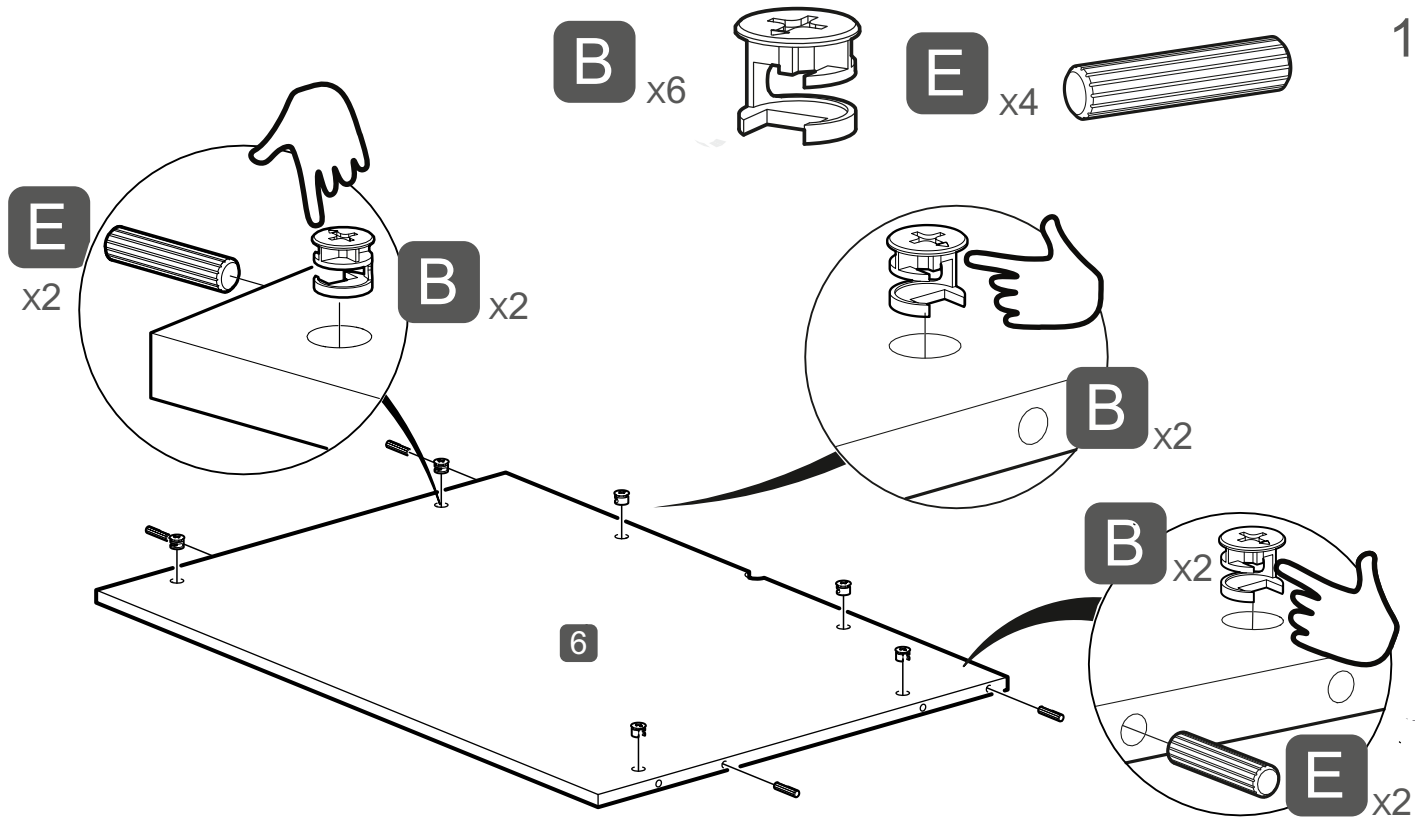

3

M

x3

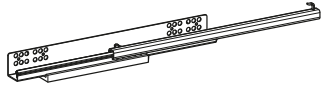

i

x12



M

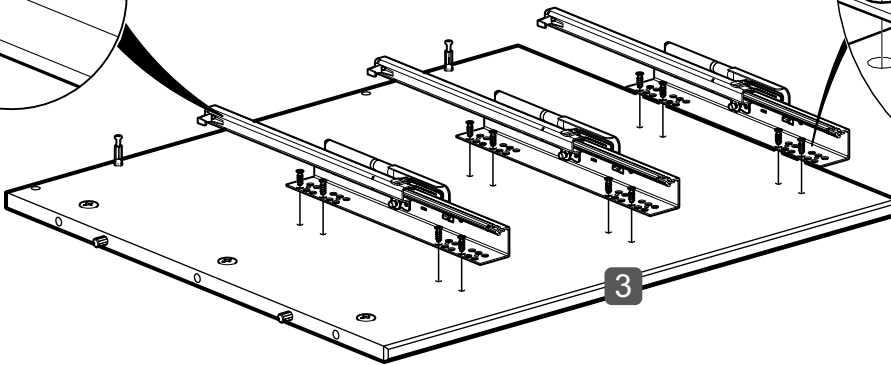
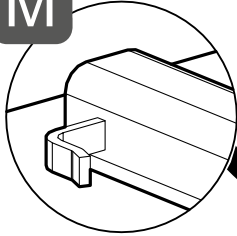

i

x12

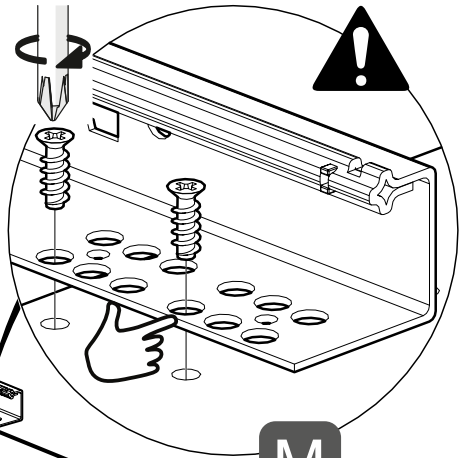

M

x3

4

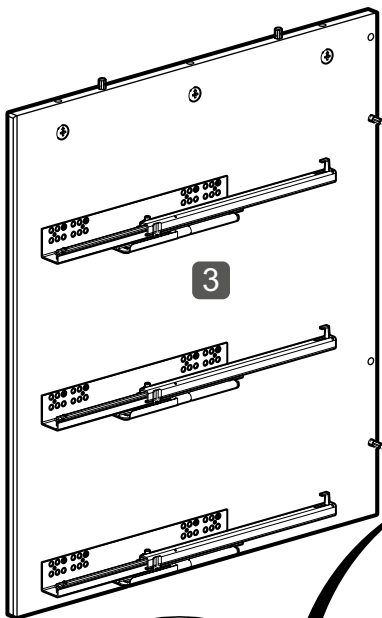

3

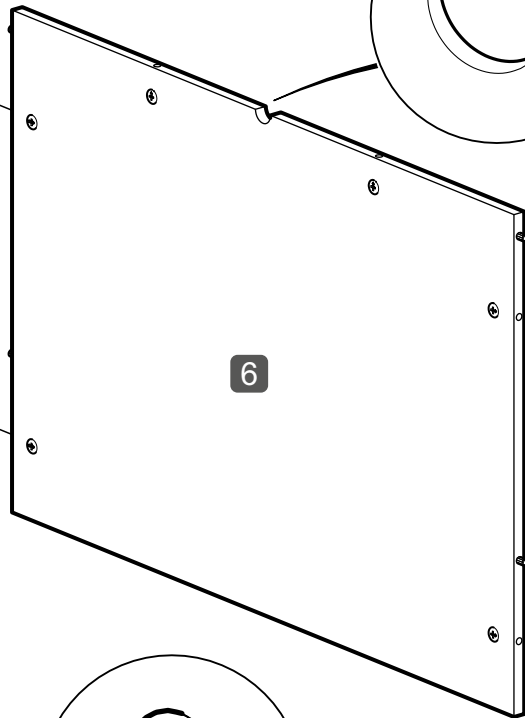

6

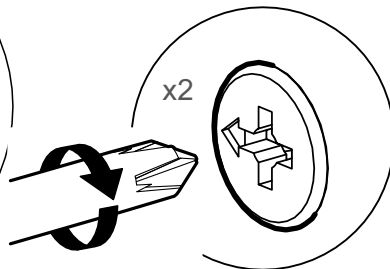
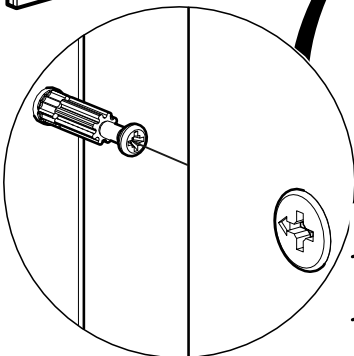

x2

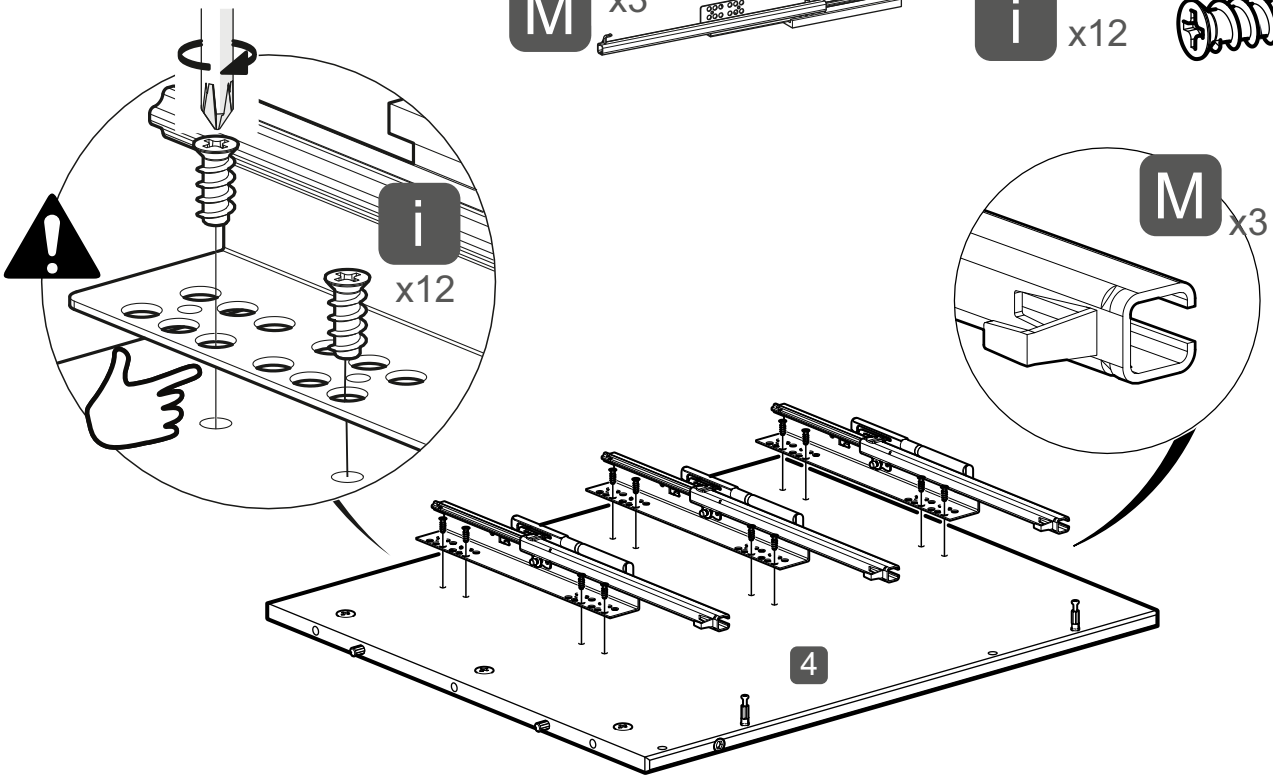
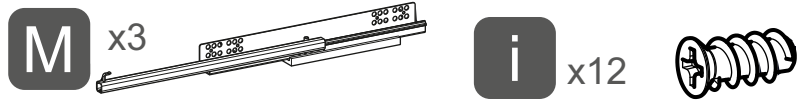
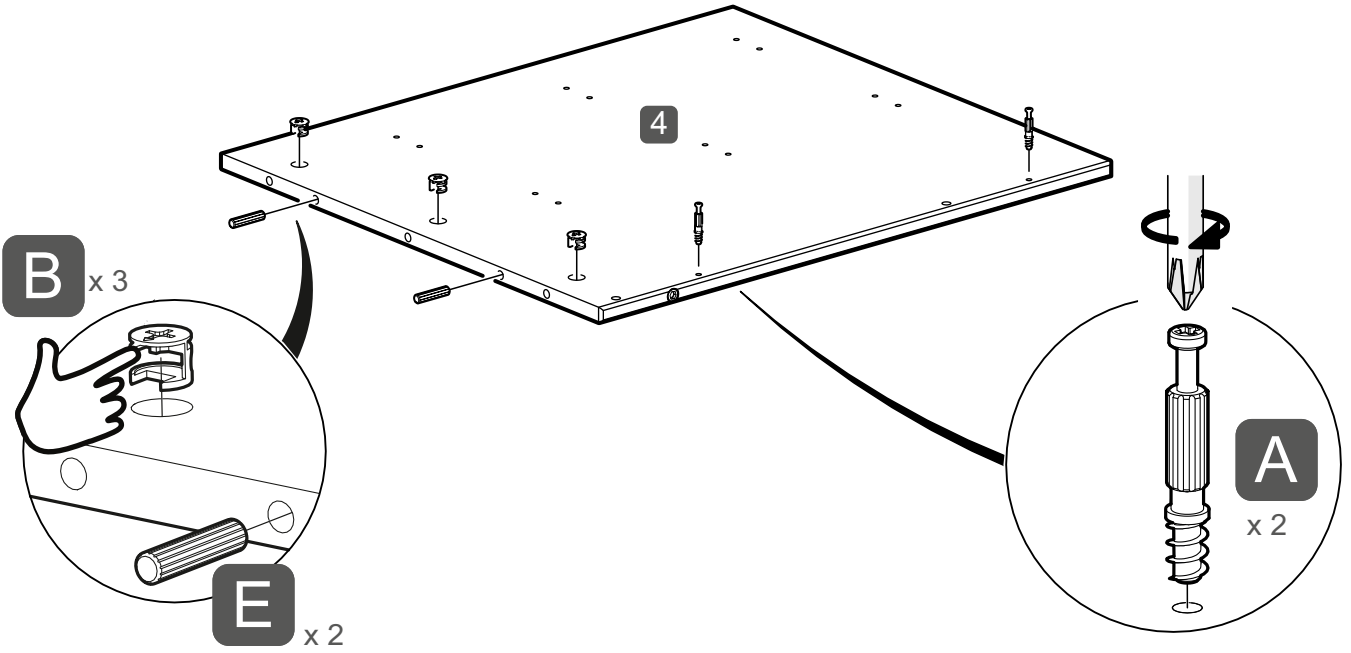
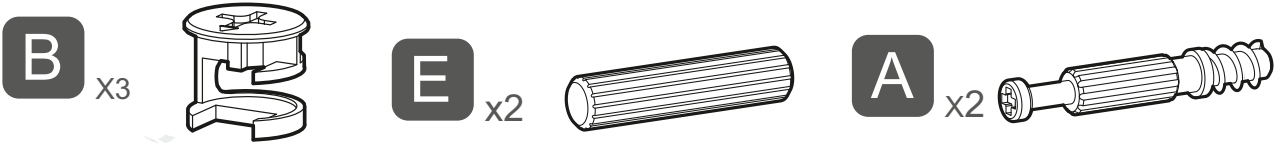

7

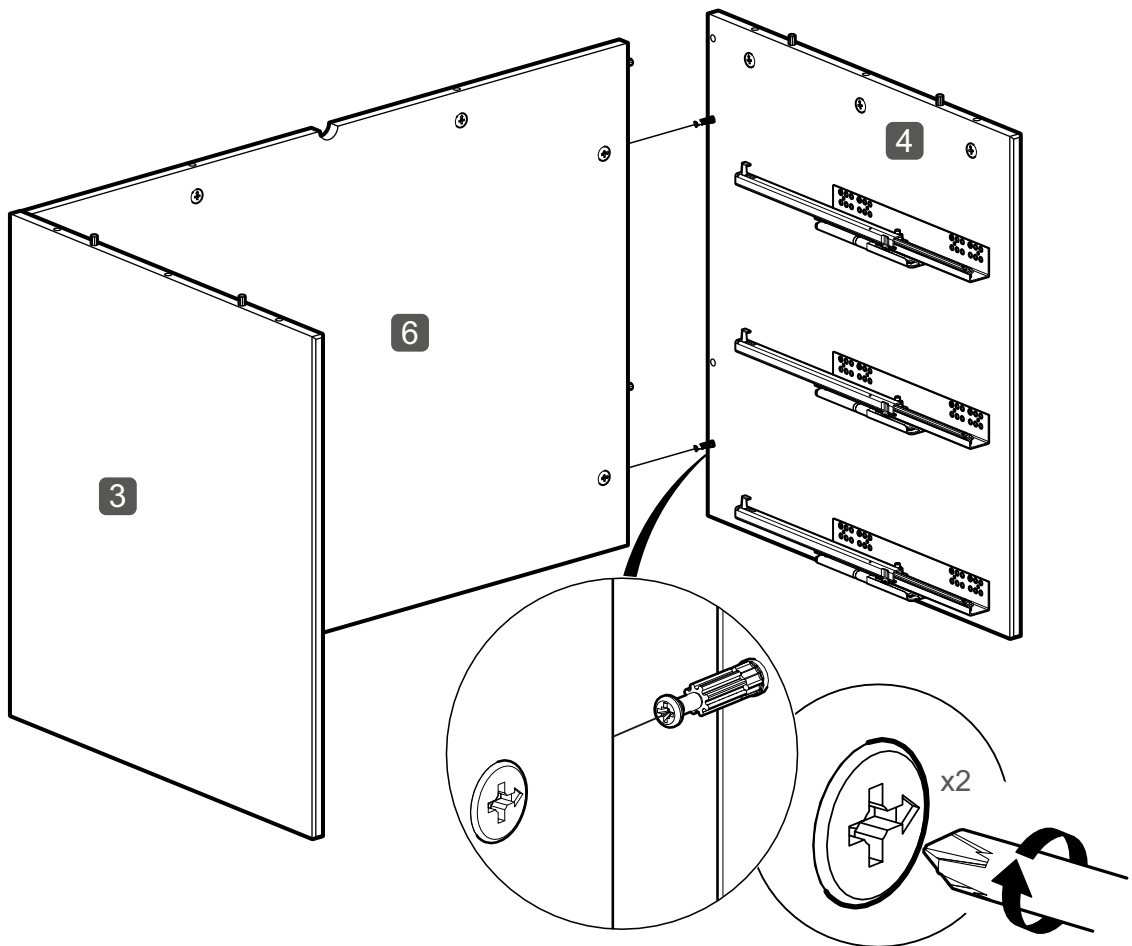

8

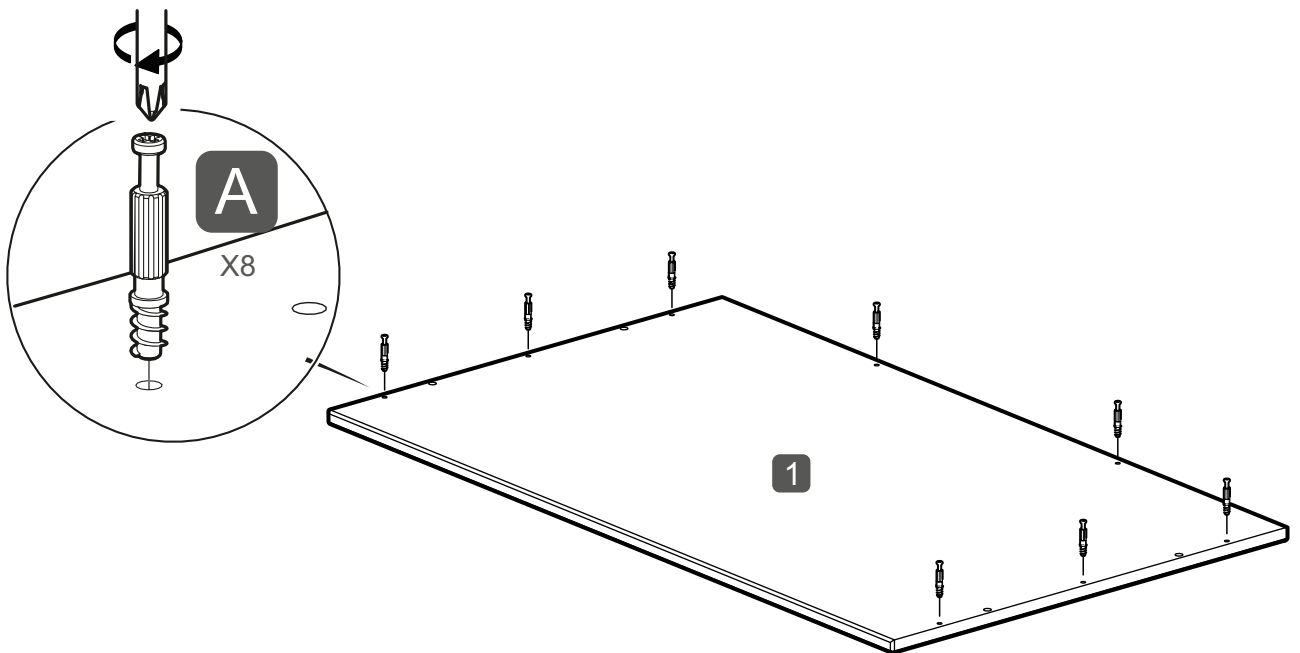
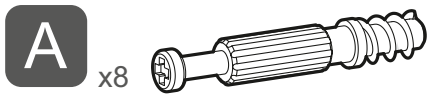

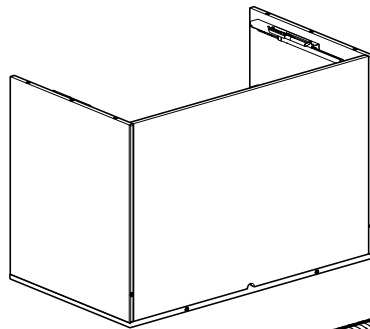
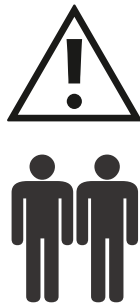
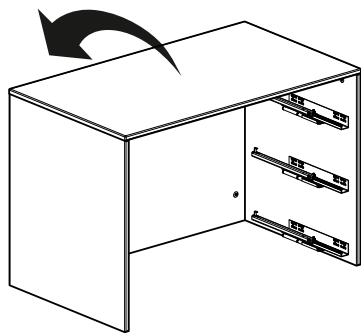
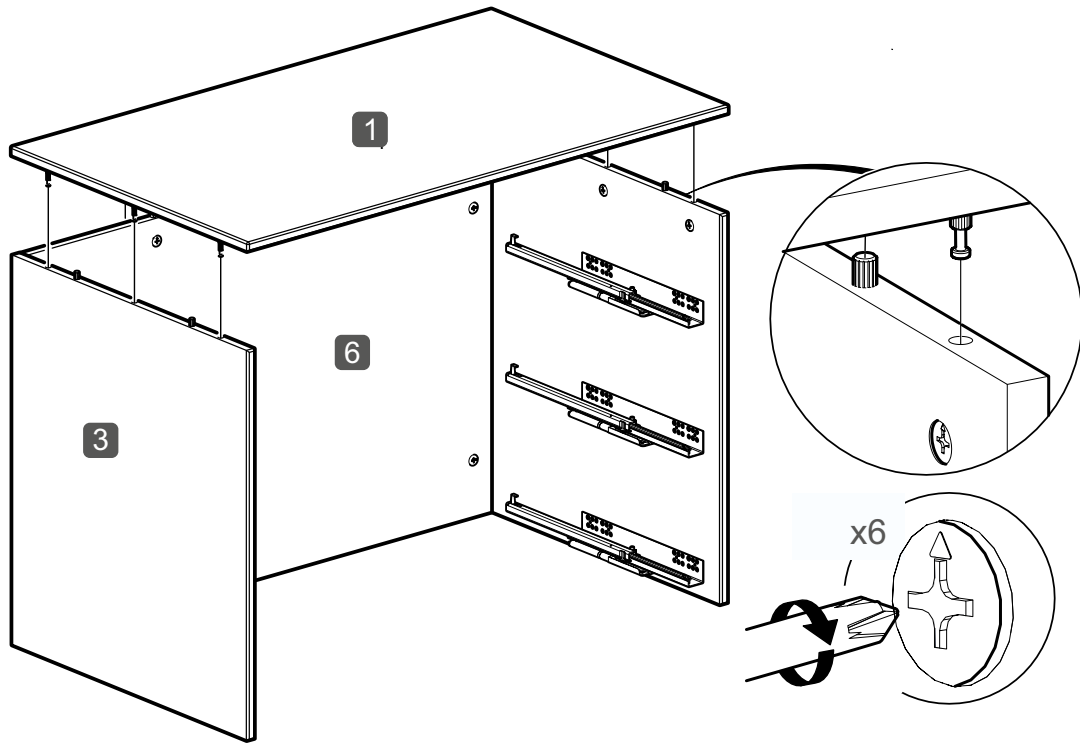

L x6

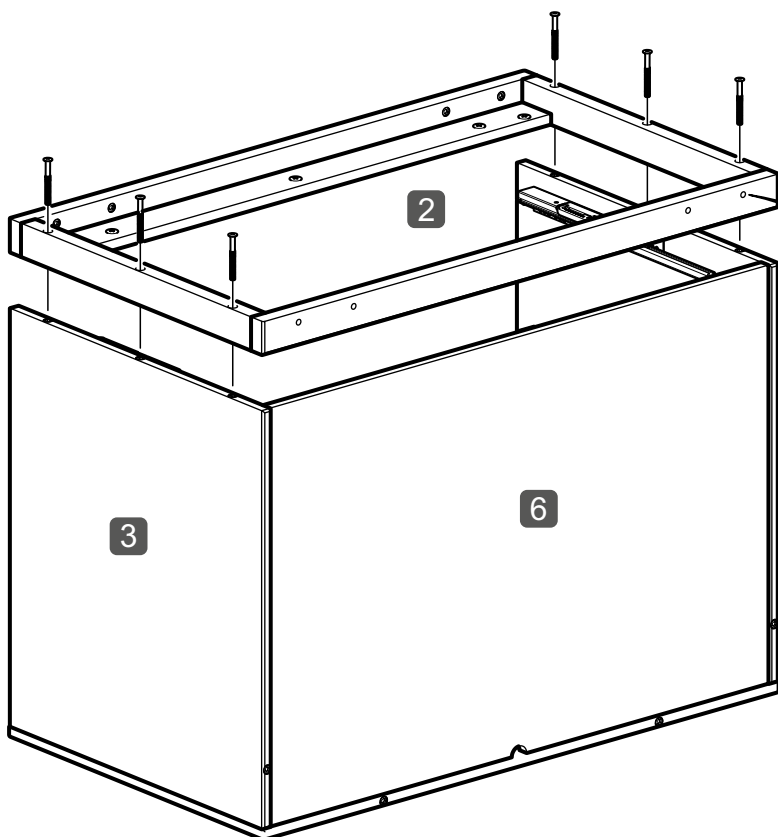
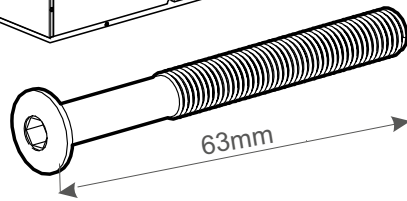

L x6

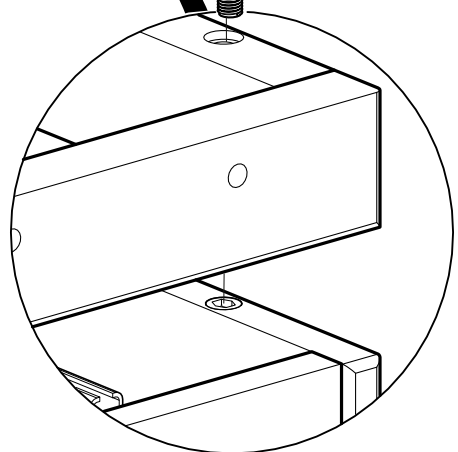

11

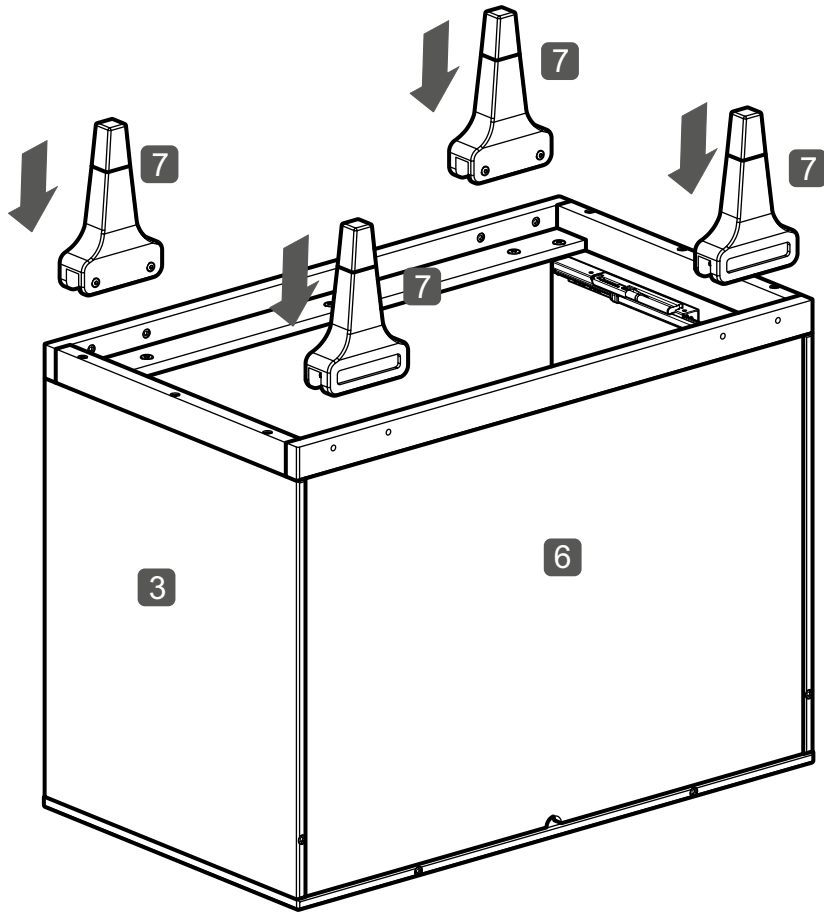

12

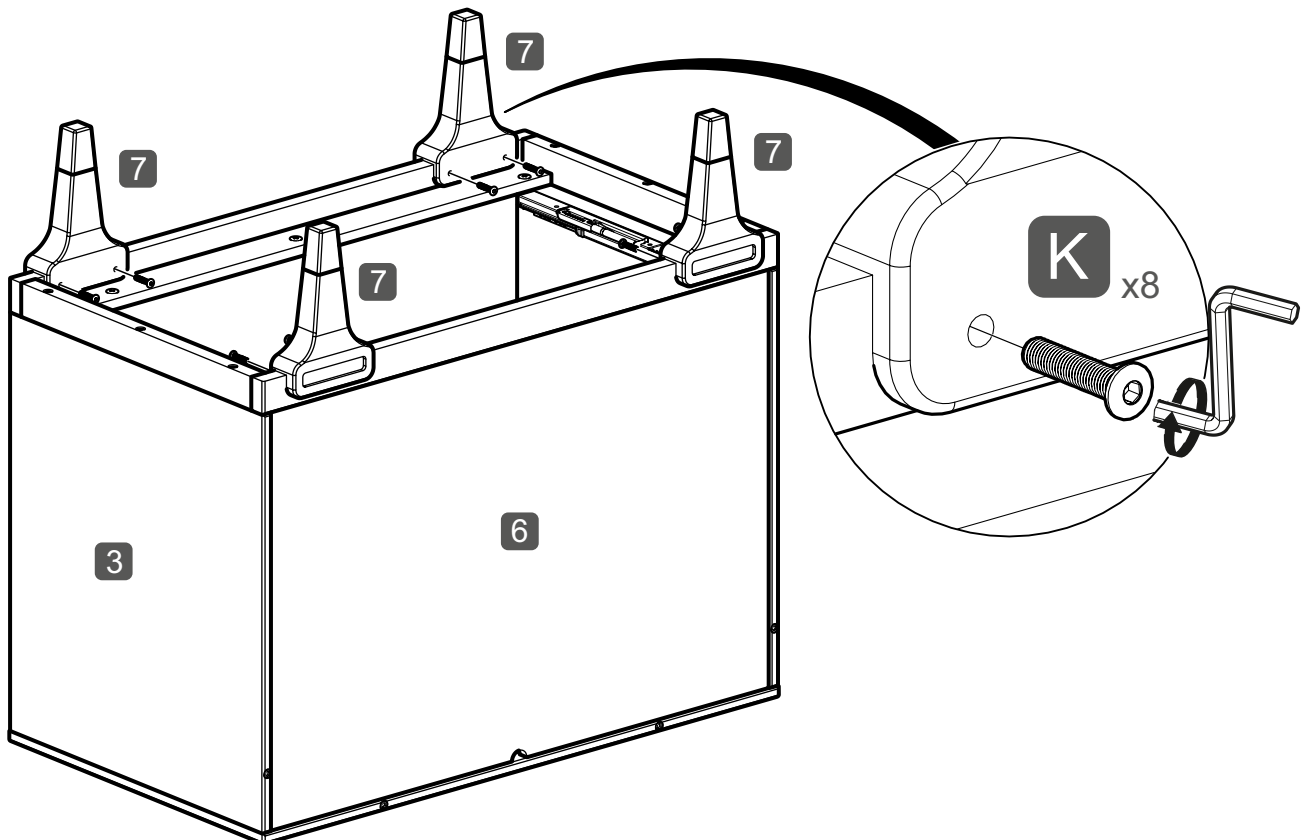
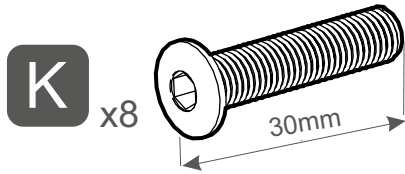

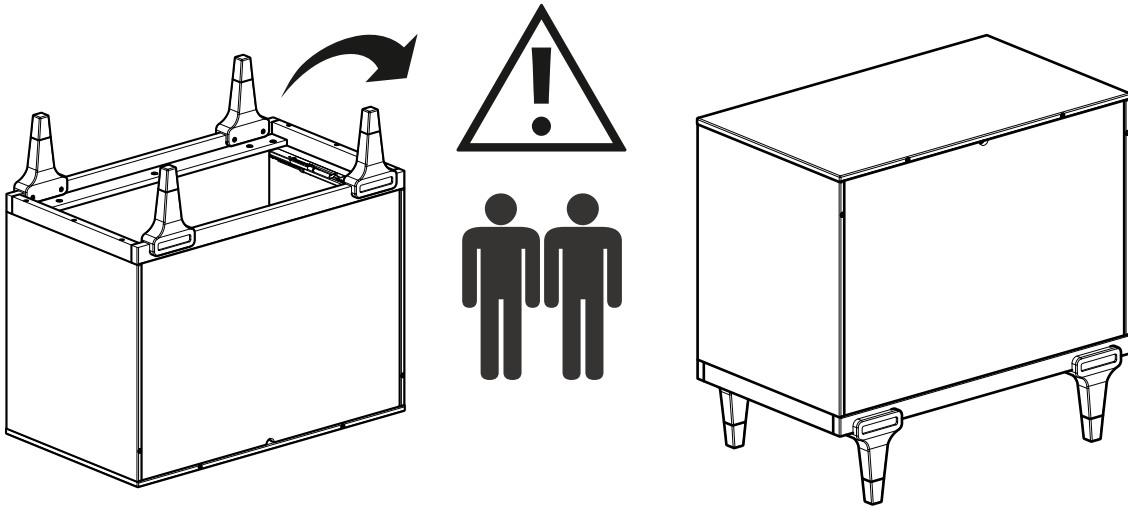

13

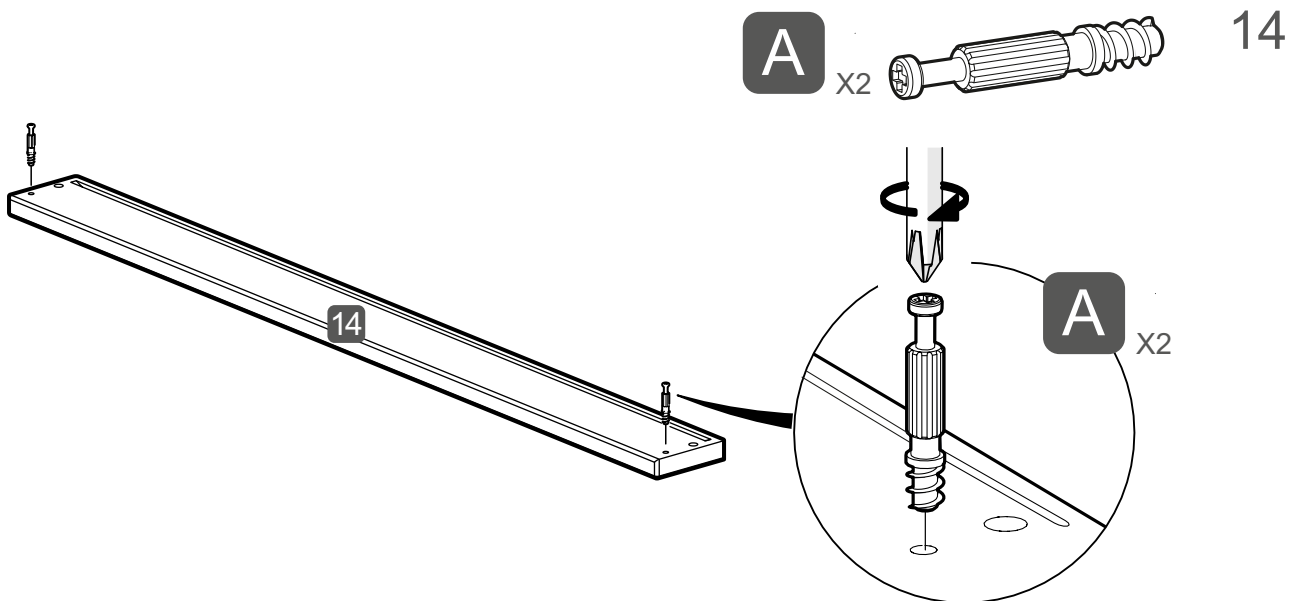
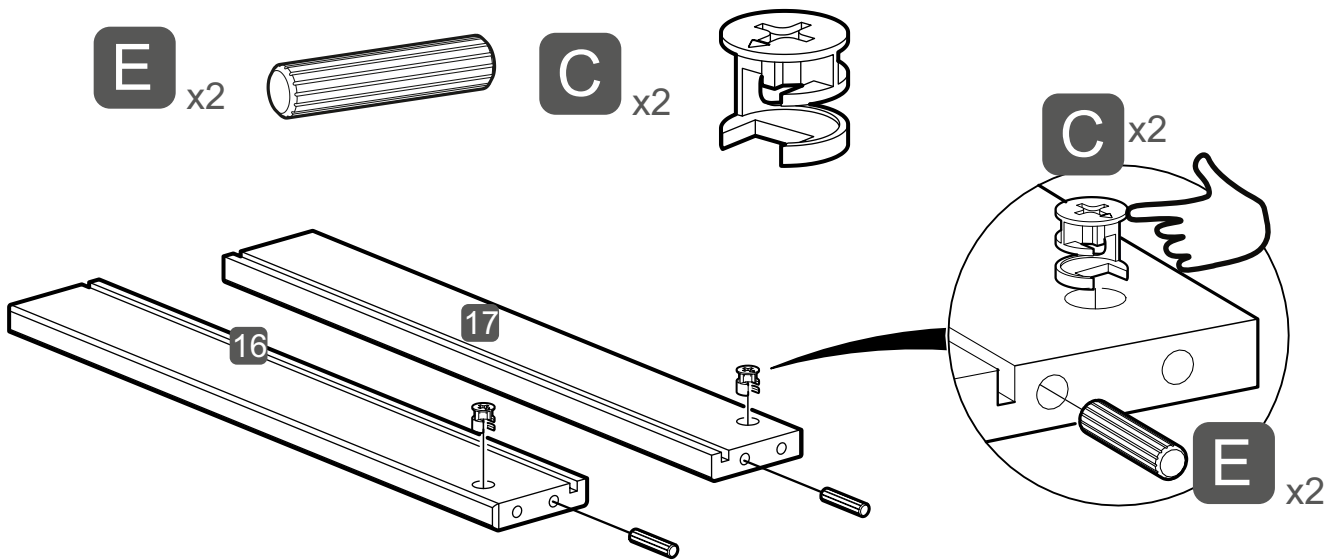

15

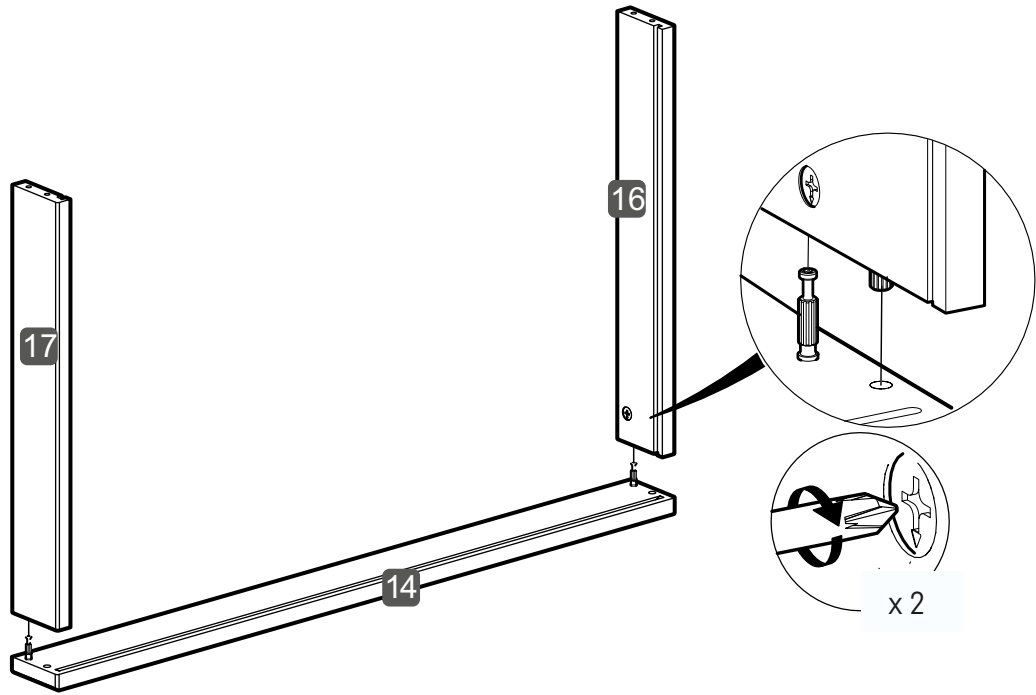

16

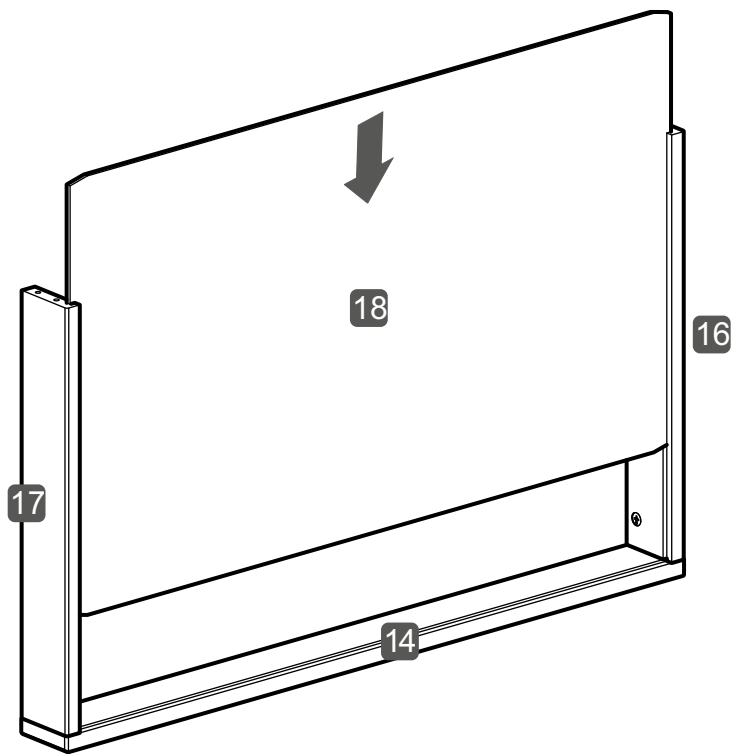

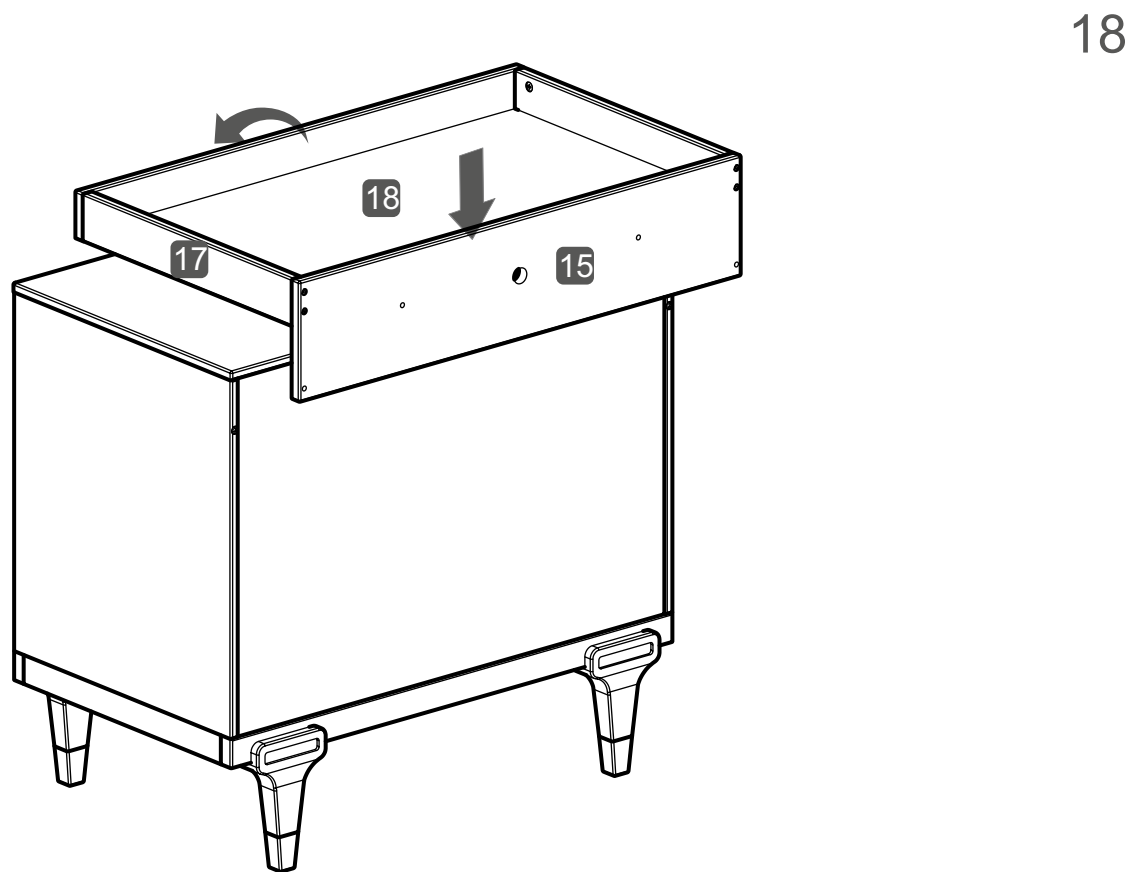
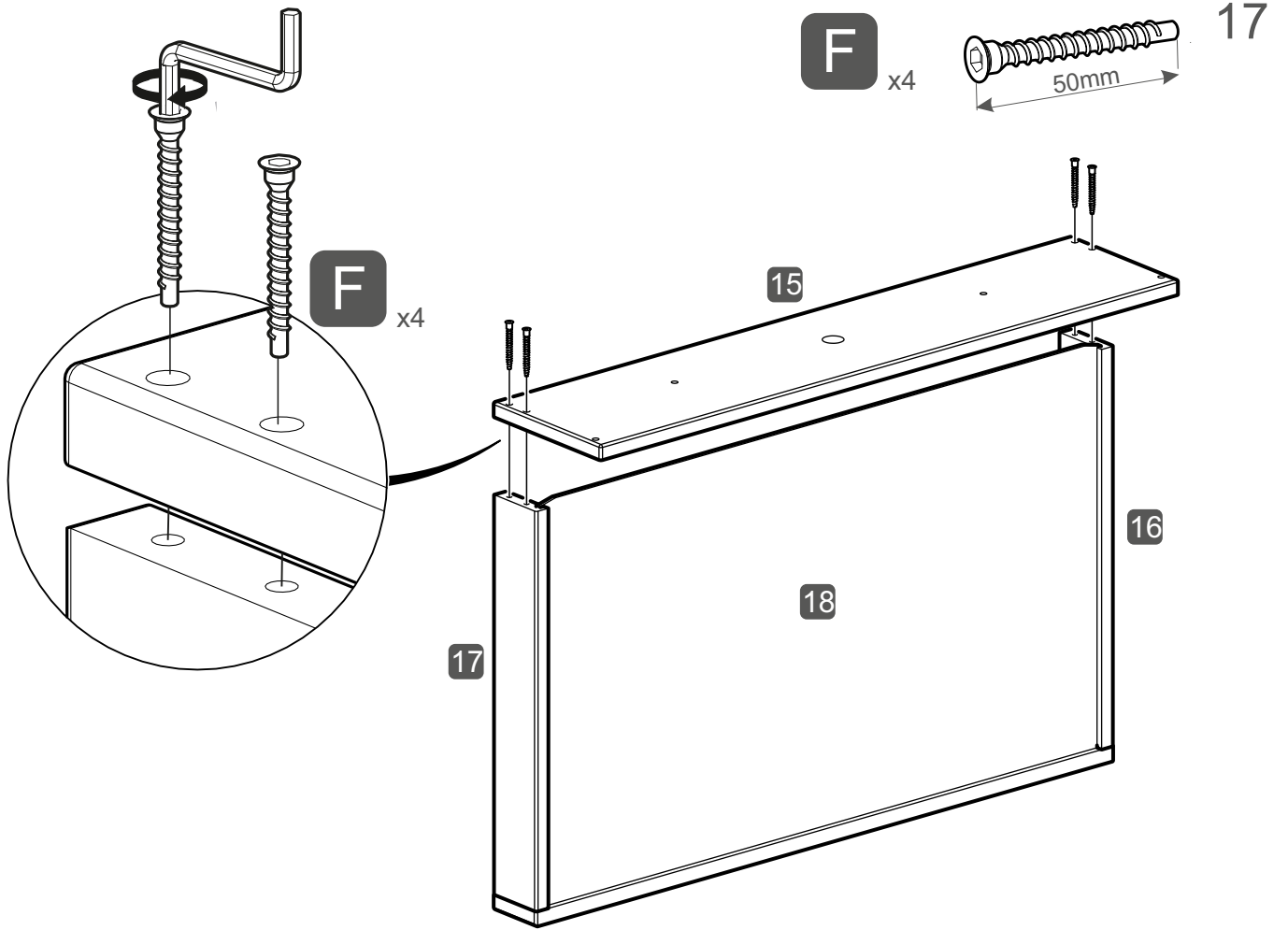

19

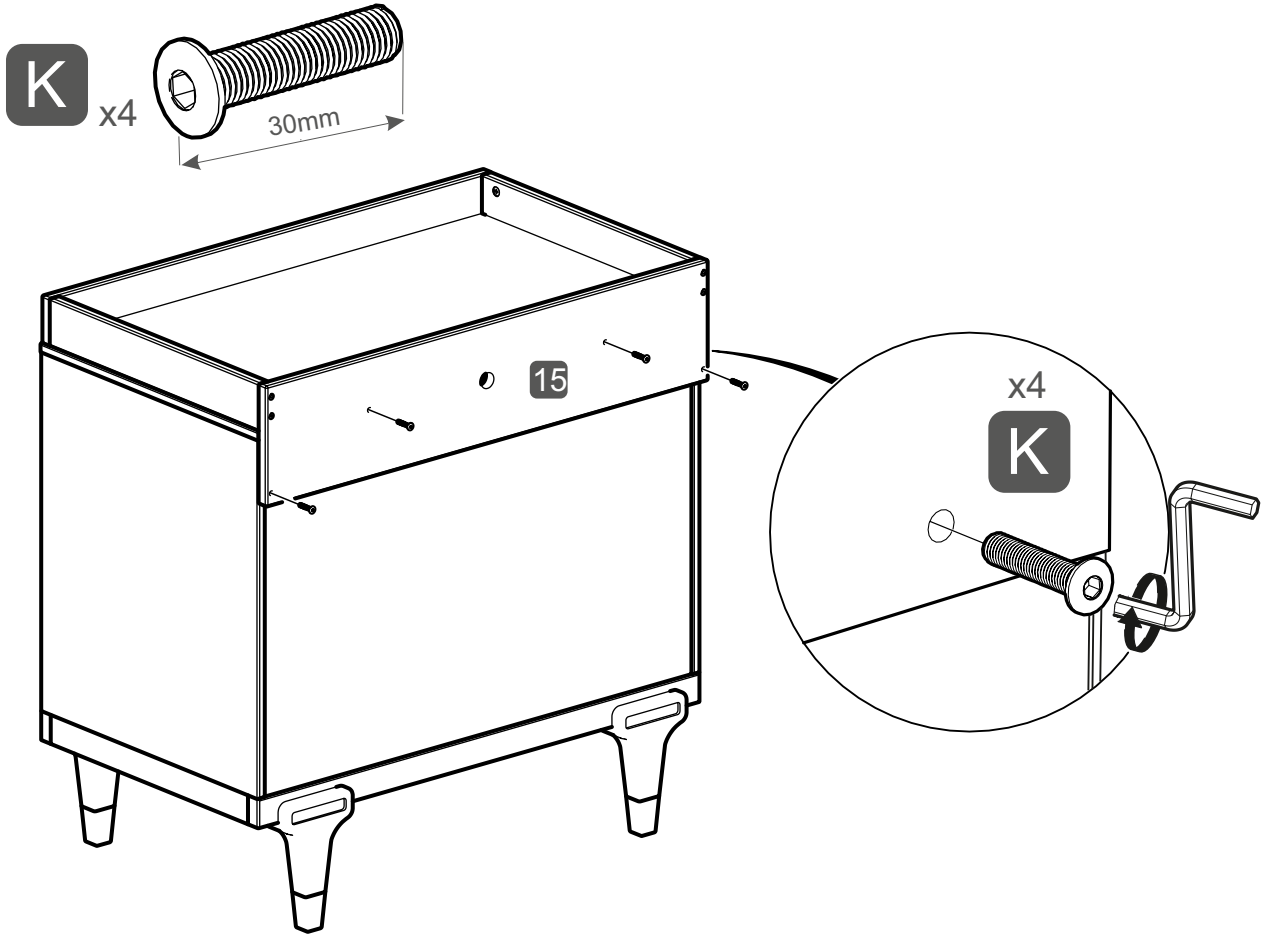

20

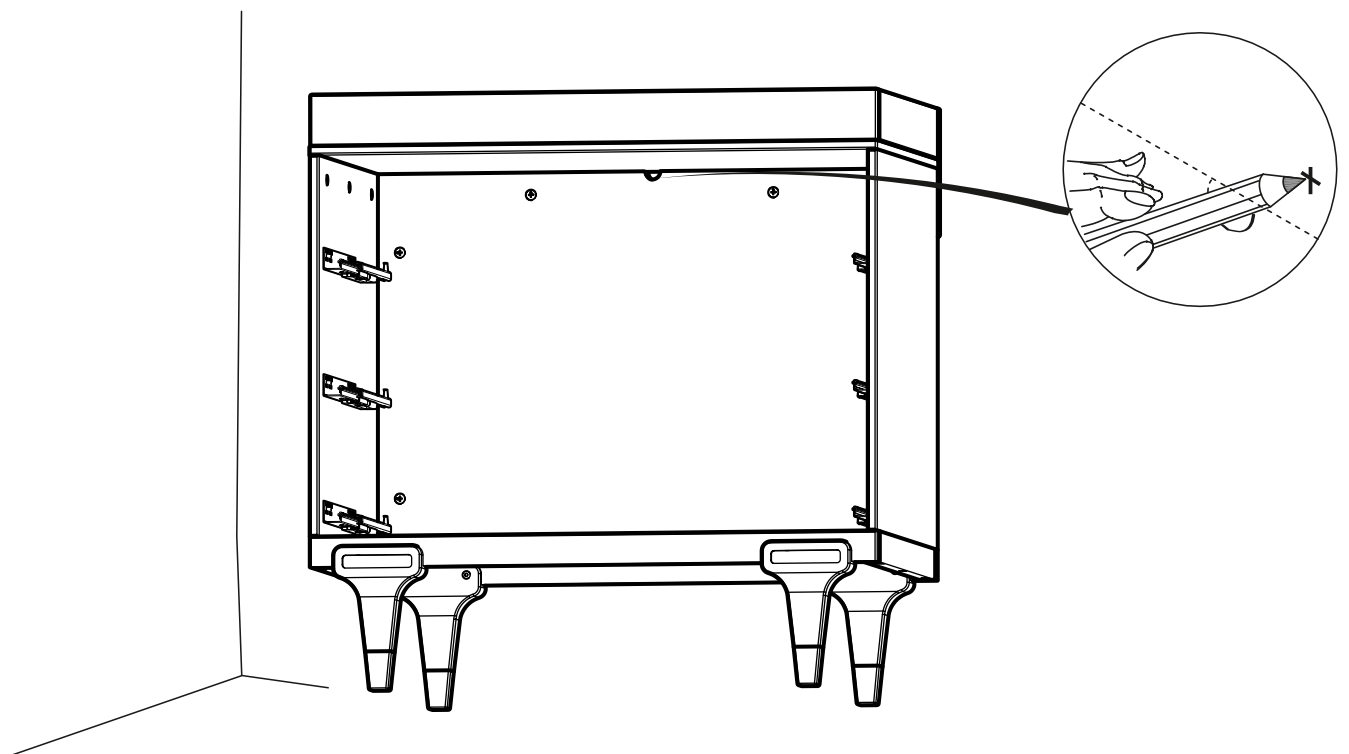
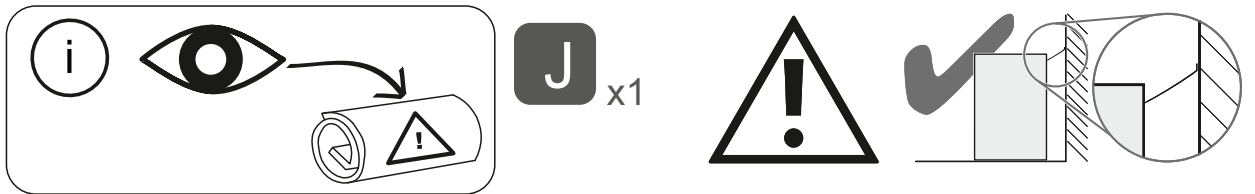

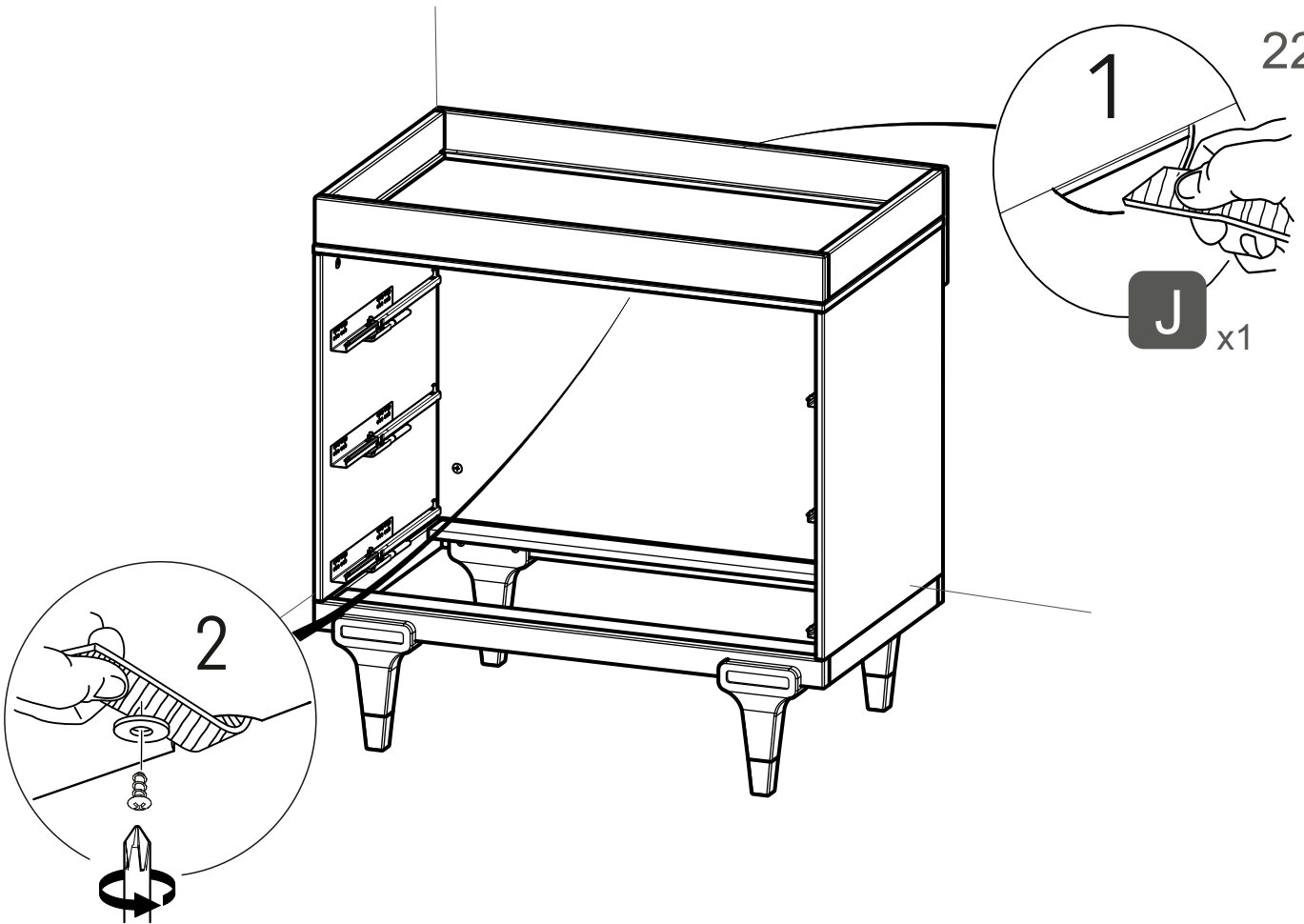
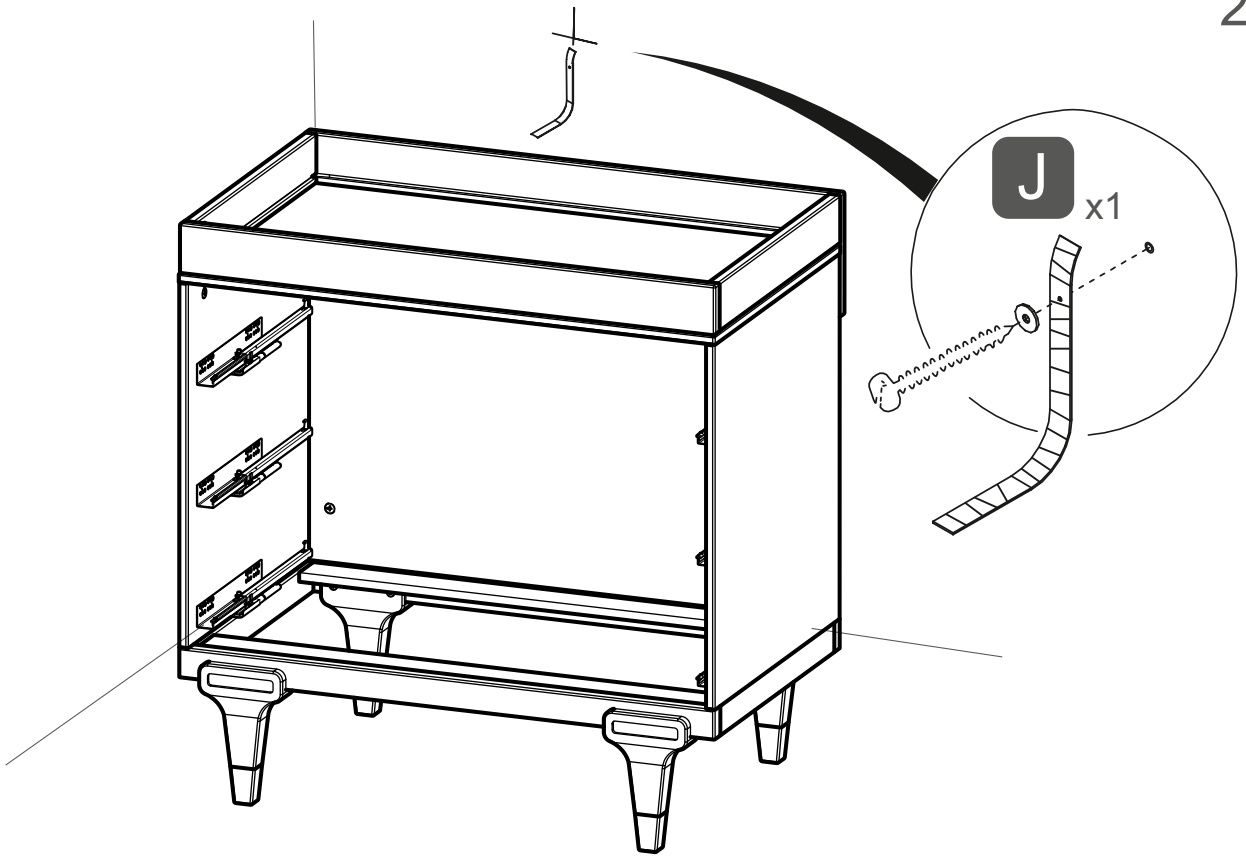

24

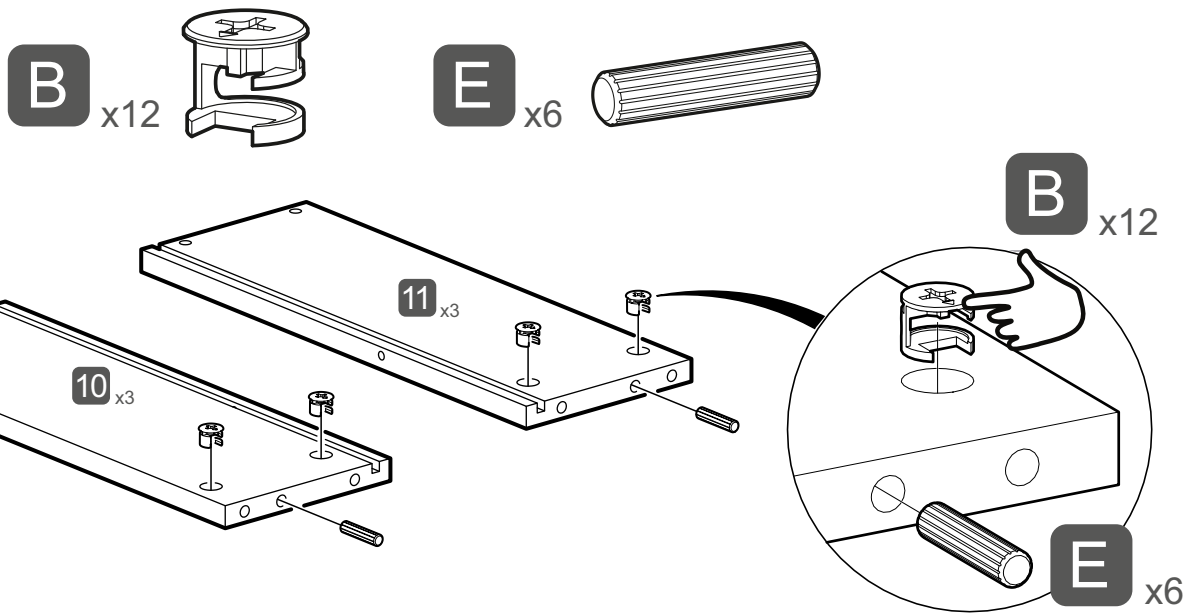

25

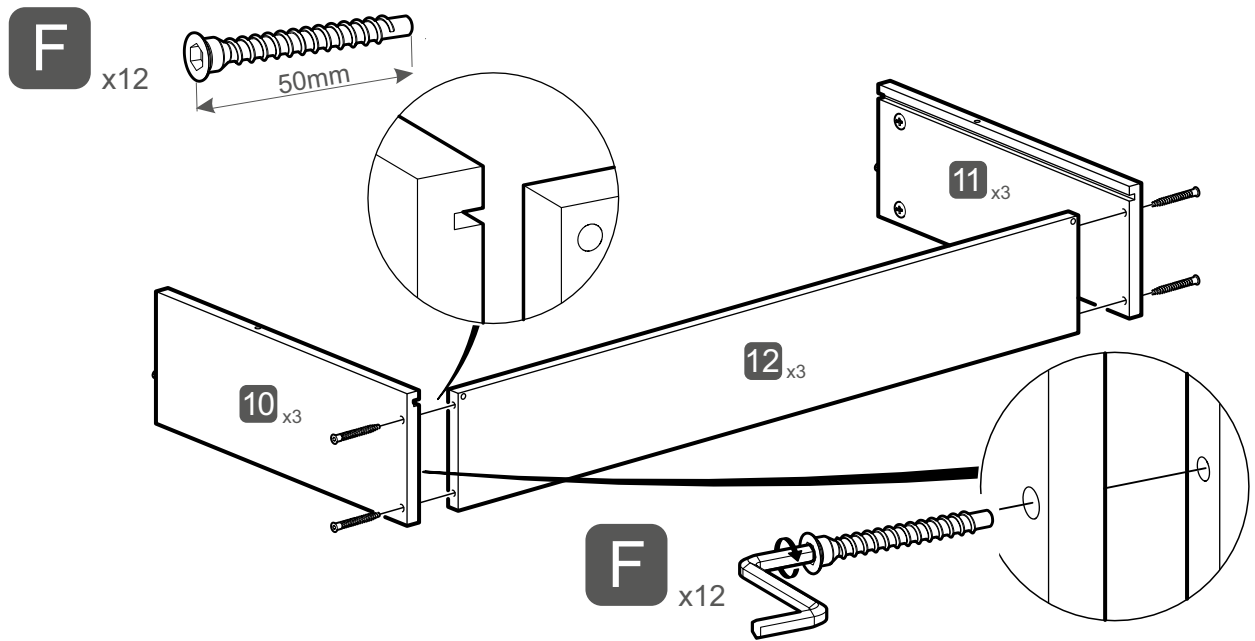

26

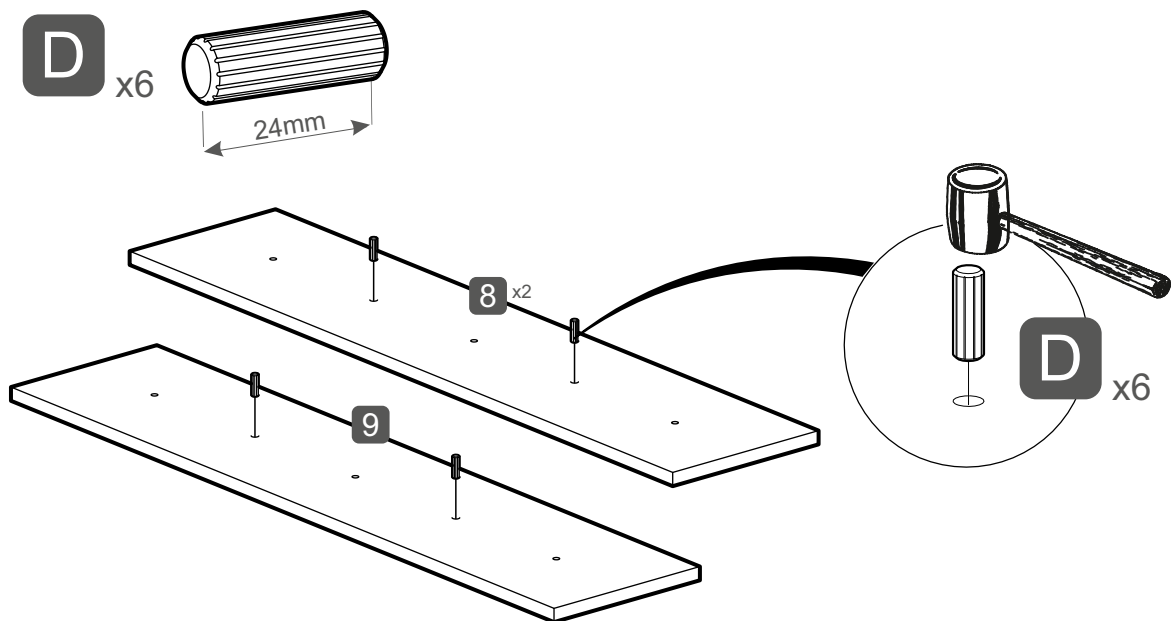

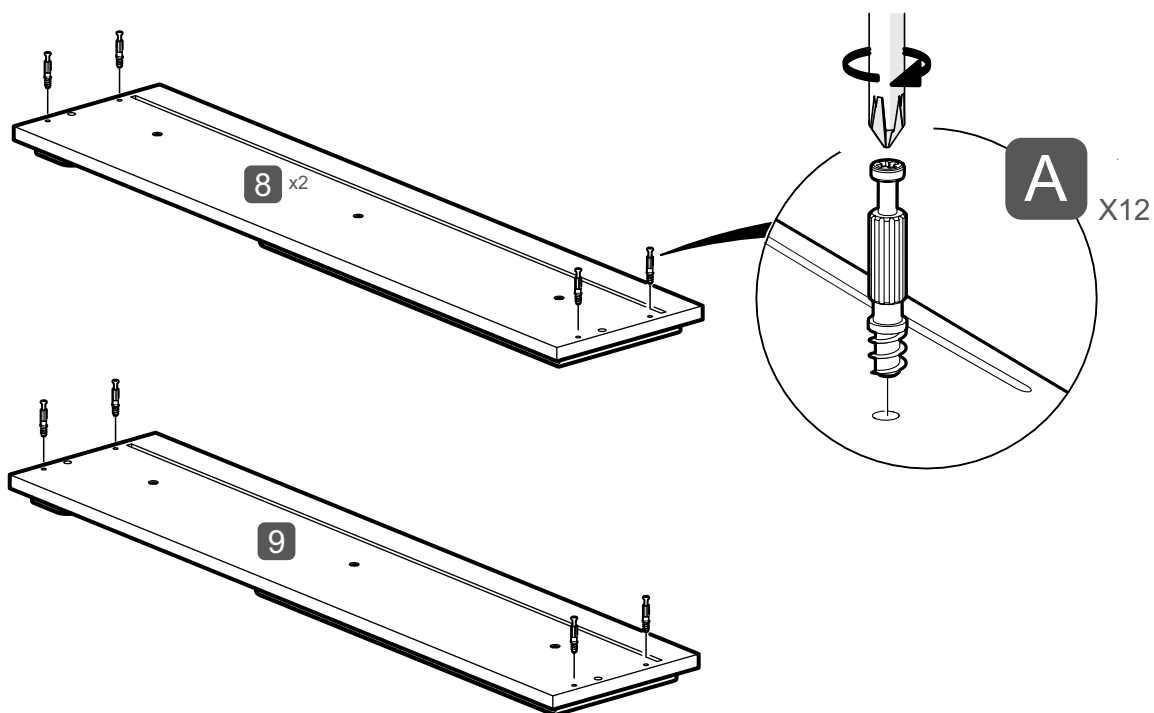
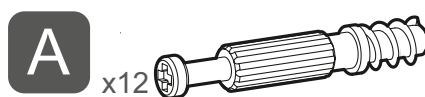
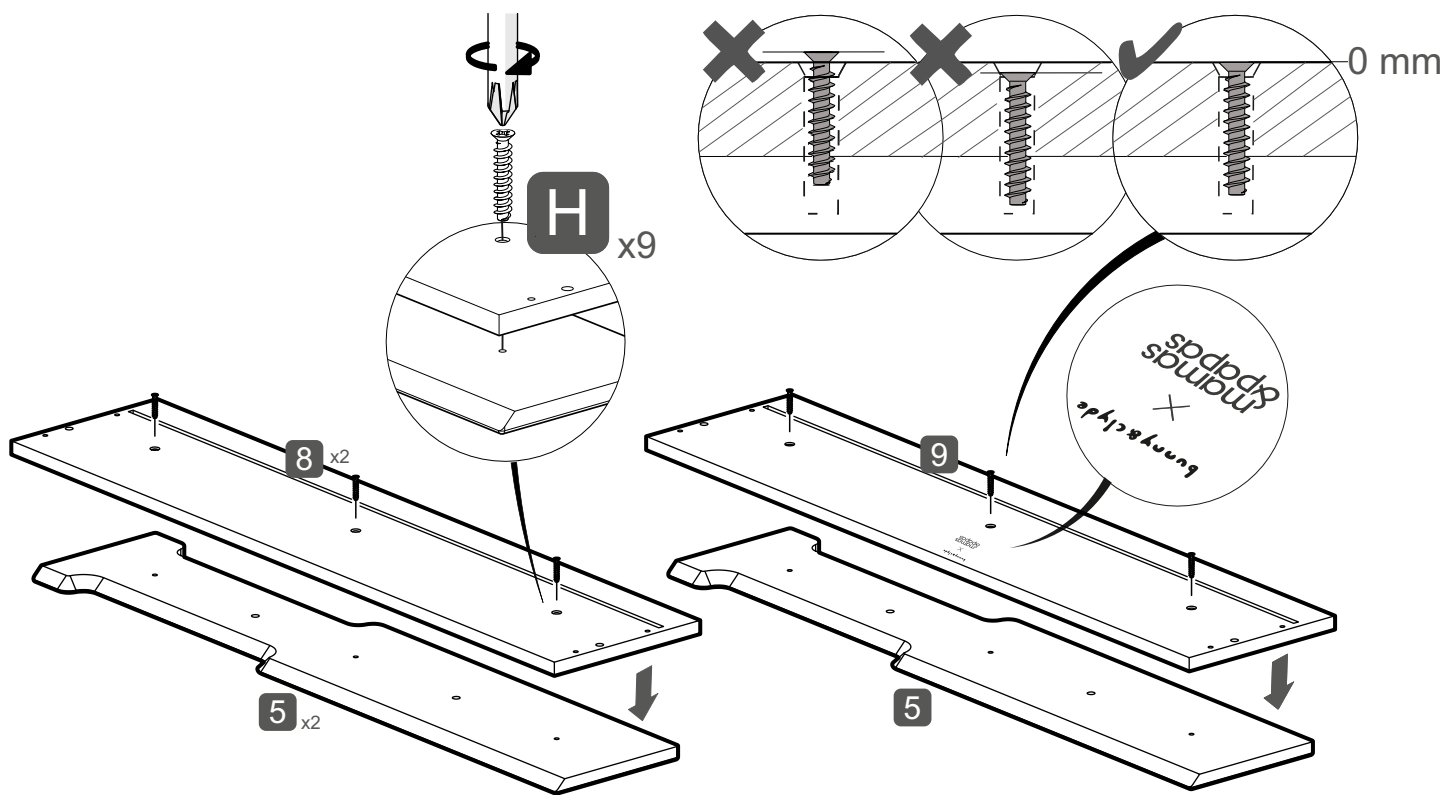
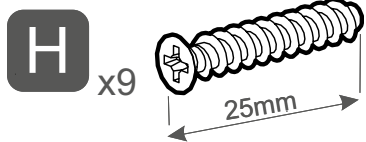

29

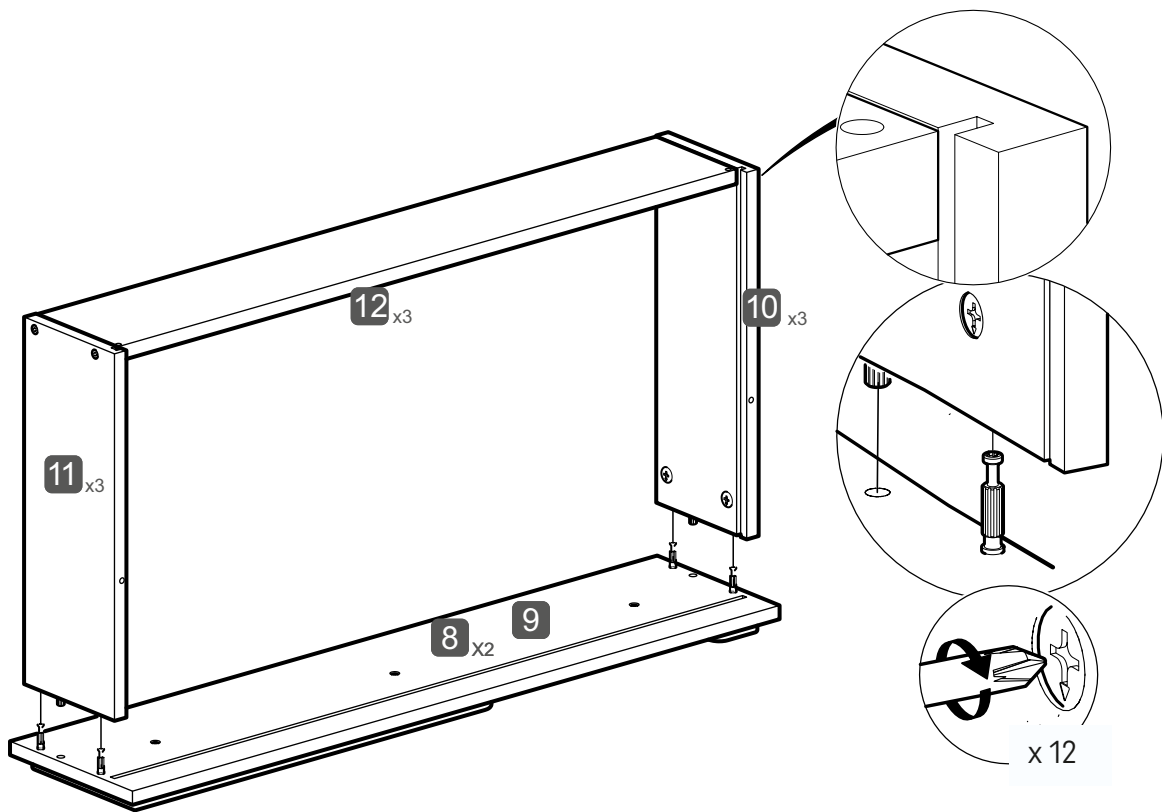

30

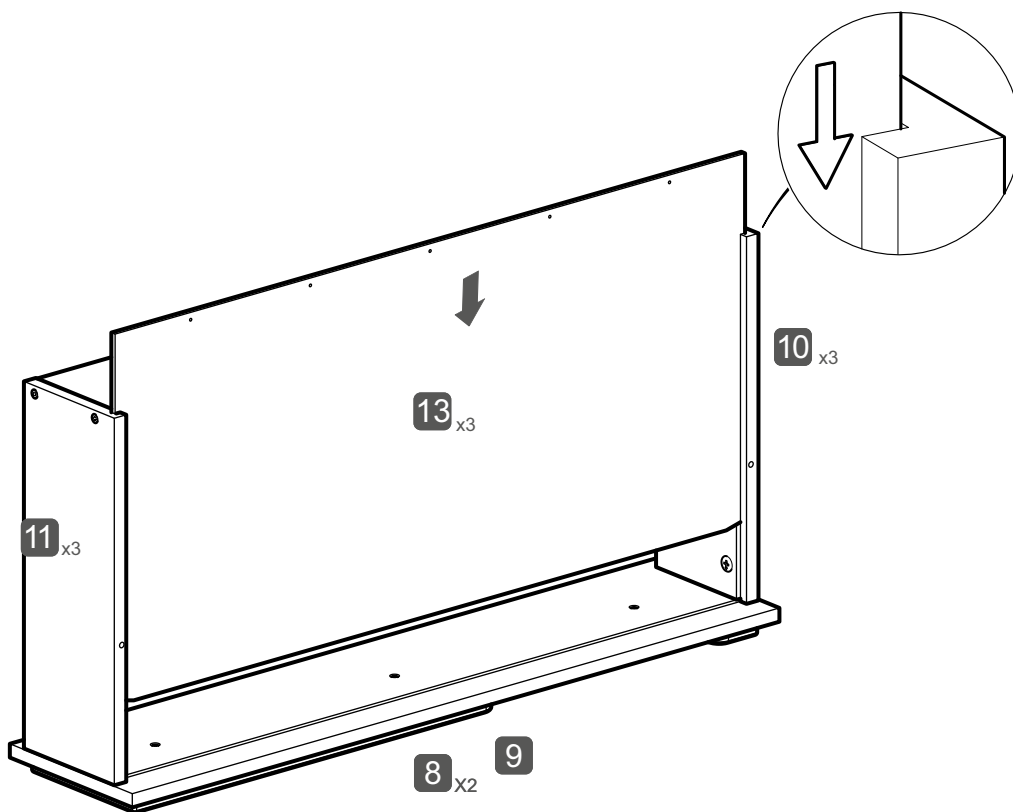

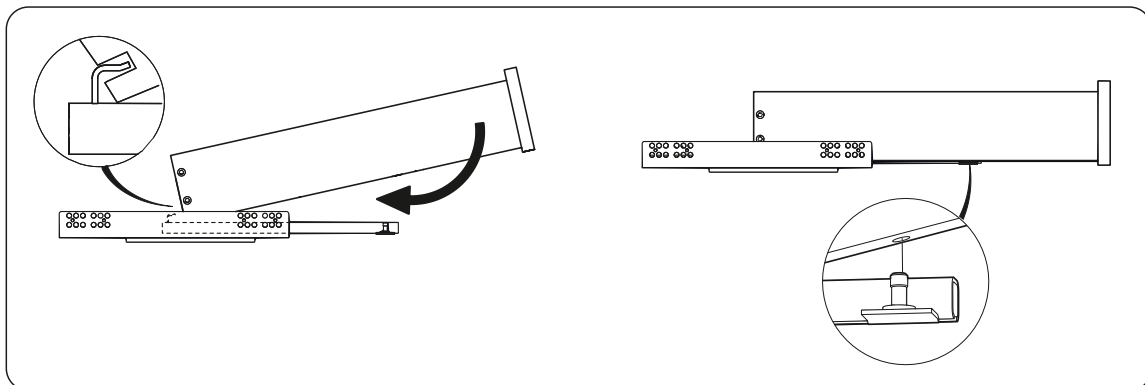
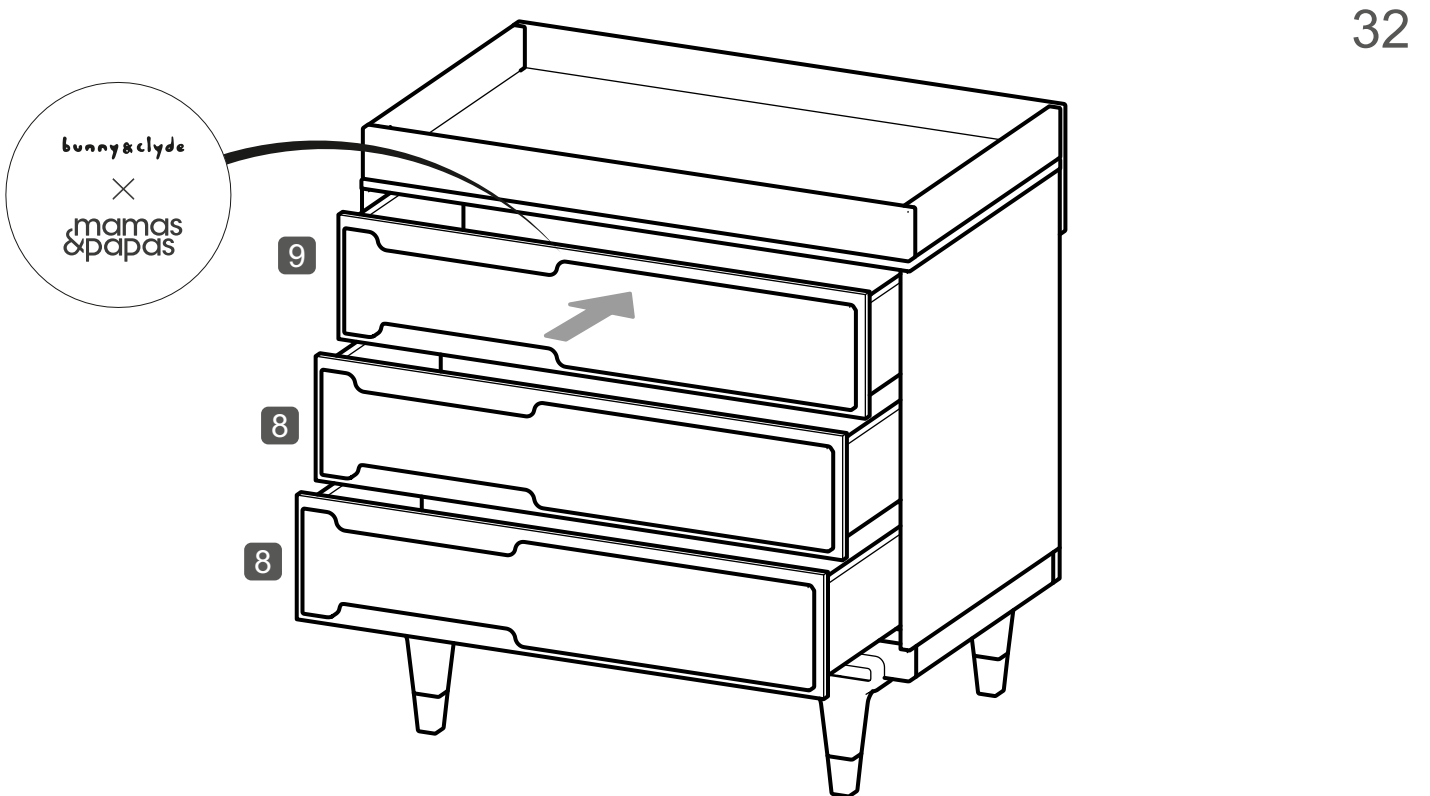
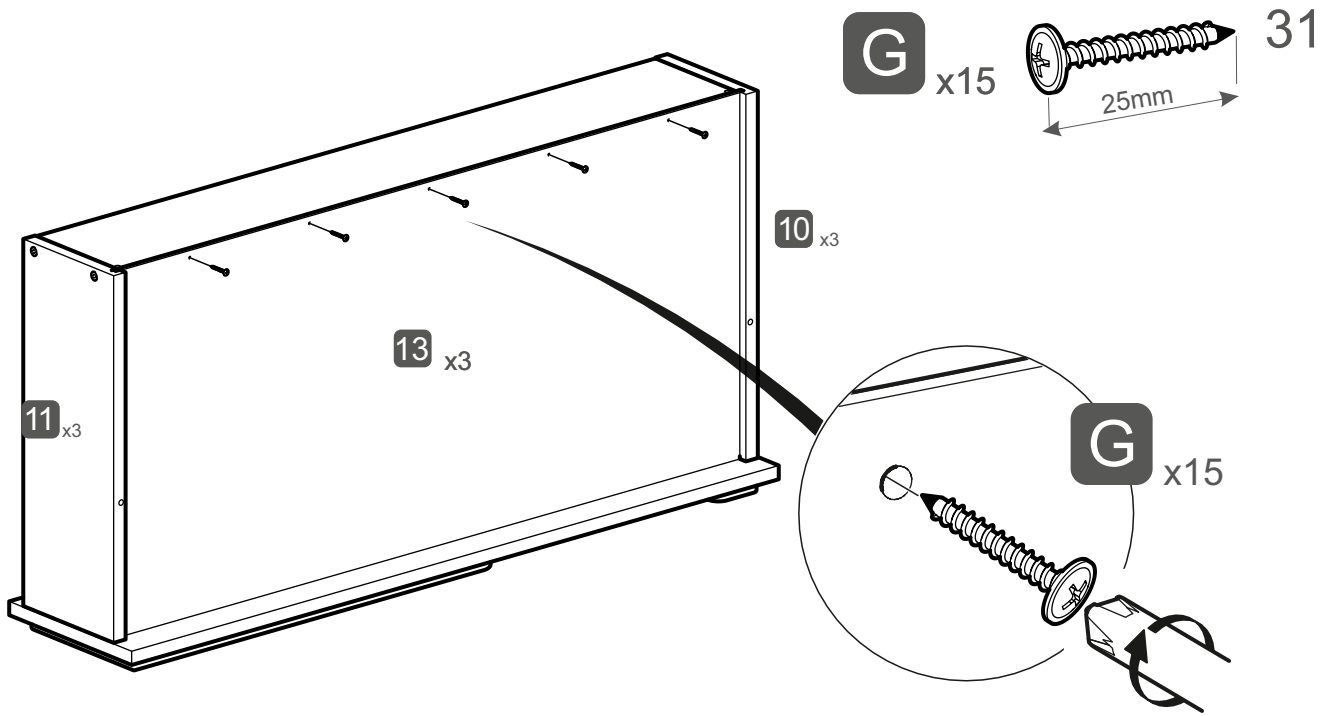

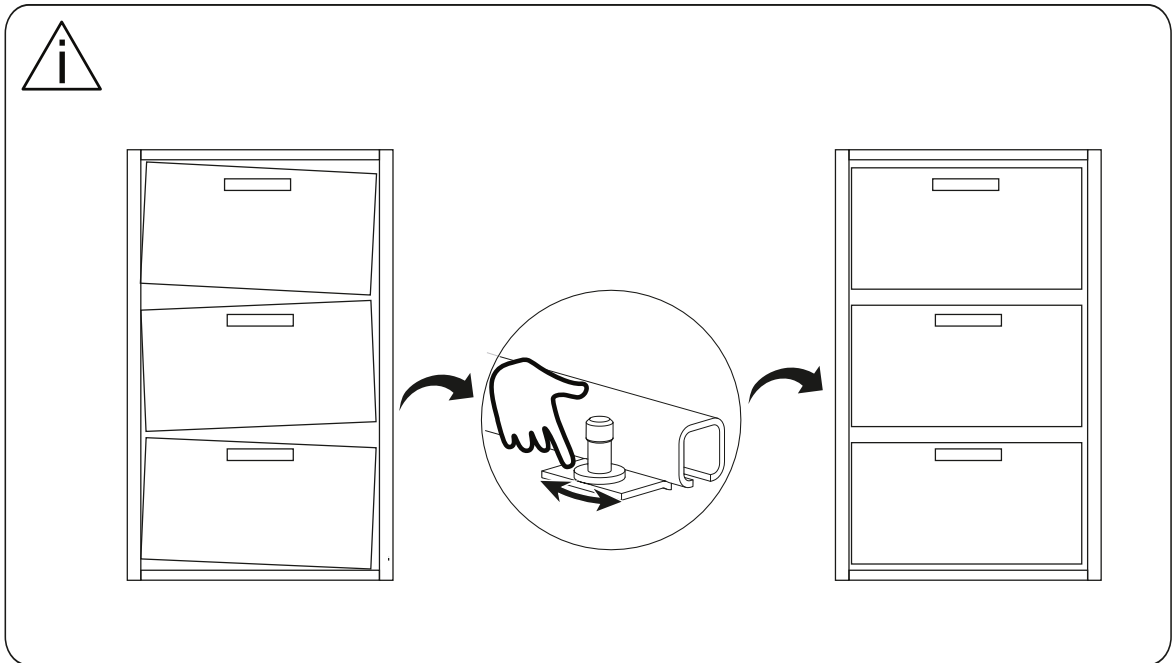

Finished

Concluido

Fini

Fertig

Finito

Voltooid

UK**WALL STRAP INFORMATION**

- The wall strap is only intended to be used with the Mamas & Papas product that it is supplied with.
- Never attempt to modify or change the wall attachment strap in any way. Never use any other fittings for attaching the strap to your furniture than those supplied.
- Never use the screw provided to attach the strap to the wall. No wall attachment fittings are supplied. This is because the type of fittings required to attach the strap to the chosen wall is determined by the composition of the wall. If you are in any doubt about the correct type of fittings to use, consult a professional before attempting to attach the strap to the wall.
- The wall strap must not be used to replace any other fitting supplied with your piece of furniture.
- Furniture falling over is generally due to the surface the furniture is placed on. A warped floor or wall-to-wall carpeting will enable the furniture to rock, so greatly increasing the potential for the furniture to fall. If the furniture is placed on a flat level wood or tiled floor the risk is reduced, but we still recommend the wall strap is fitted.

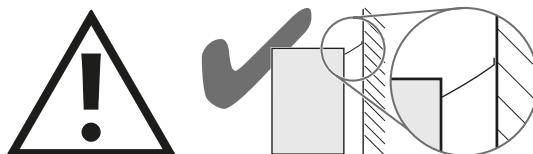
**FR****INFORMATIONS SUR LA SANGLE MURALE**

- La sangle murale est destinée à être exclusivement utilisée avec le produit Mamas & Papas avec laquelle elle est fournie.
- N'essayez jamais de modifier ou de changer la sangle de fixation murale de quelque façon que ce soit. N'utilisez jamais d'autres fixations pour fixer la sangle à vos meubles que celles fournies.
- N'utilisez jamais la vis fournie pour fixer la sangle au mur. La sangle n'est fournie avec aucune fixation murale. En effet, le type de fixation nécessaire pour fixer la sangle au mur choisi dépend de la composition du mur. En cas de doute quant au bon type de fixation à utiliser, consultez un professionnel avant d'essayer de fixer la sangle au mur.
- La sangle murale ne doit pas être utilisée pour remplacer toute autre fixation fournie avec votre meuble.
- Lorsqu'un meuble se renverse, cela est généralement dû à la surface sur laquelle il repose. Un sol ondulé ou de la moquette de mur à mur présente un risque que le meuble bascule, et donc augmente de beaucoup le risque que le meuble se renverse. Si le meuble repose sur un parquet ou un carrelage bien plat, le risque s'en trouve réduit de beaucoup, mais nous recommandons malgré tout d'utiliser la sangle murale.

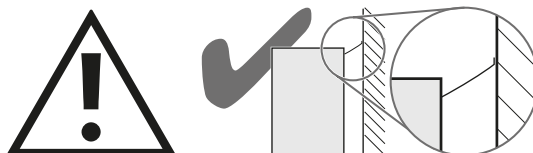
**ES****INFORMACIÓN SOBRE ANCLAJE A LA PARED**

- El anclaje a la pared ha sido diseñado para su uso exclusivo con el producto Mamas & Papas con el que ha sido suministrado.
- No intente modificar ni cambiar de modo alguno el anclaje de sujeción a la pared. No utilice ningún otro herraje diferente al que se suministra para sujetar el anclaje al mueble.
- Nunca utilice el tornillo que se suministra para sujetar el anclaje a la pared. No se suministran herrajes de sujeción. Esto se debe a que los tipos de anclajes necesarios para sujetar el anclaje a la pared elegida dependen de la composición de la pared en cuestión. Si tiene dudas sobre el tipo correcto de herrajes a utilizar, consulte a un profesional antes de intentar sujetar el anclaje a la pared.
- El anclaje no debe ser utilizado para sustituir a ningún otro herraje suministrado con el mueble.
- Cuando se produce la caída de un mueble, ésta se debe normalmente a la superficie sobre la que está colocado. Un suelo abombado o una moqueta de pared a pared permitirán que el mueble oscile incrementando con ello enormemente la posibilidad de que caiga. Si el mueble está colocado sobre un suelo llano de madera o baldosa se reduce el riesgo, pero aún en ese caso recomendamos la colocación del anclaje a la pared.

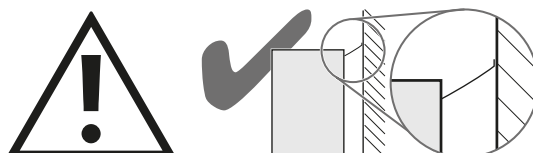

D**HINWEISE FÜR EINE SICHERE VERWENDUNG**

- Der Wandriemen ist nur zur Verwendung mit dem von Mamas & Papas gelieferten Produkt vorgesehen.
- Versuchen Sie niemals, den Wandbefestigungsriemen in irgendeiner Weise zu verändern. Verwenden Sie nur die im Lieferumfang enthaltenen Befestigungen zum Anbringen des Riemens an Ihrem Möbelstück.
- Verwenden Sie niemals die vorhandenen Schrauben, um den Riemen an der Wand zu befestigen. Im Lieferumfang sind keine Wandbefestigungen enthalten. Der Grund hierfür ist, dass die Art der zum Anbringen des Riemens an der ausgewählten Wand benötigten Befestigungen von der Zusammensetzung der Wand abhängt. Sollten Sie in Bezug auf die zu verwendenden Befestigungen irgendwelche Zweifel haben, wenden Sie sich an einen Fachmann, bevor Sie versuchen, den Riemen an der Wand zu befestigen.
- Der Wandriemen darf nicht verwendet werden, um andere Befestigungen zu ersetzen, die im Lieferumfang Ihres Möbelstücks enthalten ist.
- Das Umstürzen von Möbelstücken ist im Allgemeinen auf die Oberfläche zurückzuführen, auf die die Möbelstücke gestellt wurden. Ein verzogener Boden oder ein von Wand zu Wand ausgelegter Teppich führt dazu, dass das Möbelstück schwankt, so dass das Umsturzrisiko erhöht ist. Steht das Möbelstück dagegen auf einem flachen, waagerechten Boden aus Holz oder Fliesen, ist das Risiko geringer. Wir empfehlen dennoch, den Wandriemen anzubringen.

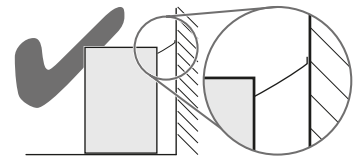
**IT****INFORMAZIONI SUL SUPPORTO DI FISSAGGIO A PARETE**

- Il supporto di fissaggio a parete deve essere utilizzato esclusivamente con il prodotto di Mamas & Papas insieme al quale viene fornito.
- Non tentare in nessun modo di modificare o manomettere il supporto di fissaggio a parete. Non usare in nessun caso attacchi diversi da quelli forniti per fissare il supporto al mobile.
- Non usare in nessun caso la vite fornita per fissare il supporto alla parete. La fornitura non comprende gli attacchi per il fissaggio a parete. Questo perché il tipo di attacchi richiesti per fissare il supporto alla parete prescelta dipende dalle caratteristiche della parete stessa. In caso di dubbi sul tipo corretto di attacchi da utilizzare, richiedere la consulenza di un professionista prima di tentare di fissare il supporto alla parete.
- Non usare il supporto di fissaggio a parete per sostituire altri attacchi forniti insieme al mobile.
- La caduta del mobile è solitamente causata dal tipo di superficie sulla quale questo viene posizionato. Un pavimento irregolare o interamente rivestito di moquette tenderà a bloccare il movimento del mobile, aumentando notevolmente le possibilità che questo cada o si rovesci. Qualora il mobile sia posizionato su un pavimento piano in legno o mattonelle, il rischio viene ridotto. Si raccomanda tuttavia il fissaggio alla parete tramite l'apposito supporto.

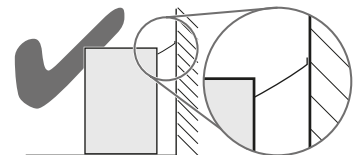
**NL****INFORMATIE WANDBEVESTIGINGSRIEM**

- De wandbevestigingsriem is uitsluitend bedoeld om te gebruiken met het product van Mamas & Papas waarbij het wordt geleverd.
- Probeer de wandbevestigingsriem op geen enkele wijze aan te passen of te veranderen. Gebruik geen andere bevestigingsmaterialen om de riem aan uw meubelstuk vast te maken dan degene die zijn geleverd.
- De geleverde schroef niet gebruiken om de riem aan de muur te bevestigen. Het product wordt geleverd zonder materialen om deze aan de muur te bevestigen. Dit is gedaan, omdat het soort bevestigingsmateriaal om de riem aan de muur te bevestigen, afhankelijk is van de samenstelling van de muur. Mocht u twijfelen over het juiste type bevestigingsmateriaal dat gebruikt moet worden, raadpleeg dan een deskundige voordat u probeert de riem aan de muur te bevestigen.
- De wandbevestigingsriem moet niet als vervanging worden gebruikt van andere bevestigingsmaterialen die bij een meubelstuk worden geleverd.
- Het omvallen van een meubelstuk heeft meestal te maken met de ondergrond waarop het meubelstuk is geplaatst. Door een kromgetrokken vloer of een kamerbrede vloerbedekking kunnen meubelstukken wiebelen, waardoor de mogelijkheid om om te vallen sterk wordt vergroot. Het risico is minder als het meubelstuk is geplaatst op een gelijke, vlakke houten of betegelde vloer, desondanks adviseren we de wandbevestigingsriem aan te brengen.

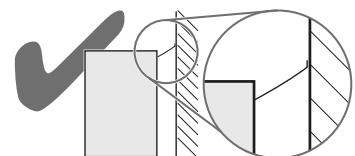

UK



WARNING:

- DO NOT LEAVE THE CHILD UNATTENDED. The safety of your child is your responsibility
- In order to prevent overturning this product must be used with the wall attachment device provided
- This product is intended for children from birth up to 11kg (12 months approximately).
- Check regularly that all the fittings and screws are correctly tightened and are not damaged. Loose screws can pinch parts of the body and clothing resulting in the risk of strangulation.
- Do not use replacement parts that are not recommended or supplied by Mamas & Papas.
- Be aware of the risk of open fire and other sources of strong heat, such as electric bar fires, gas fires, etc. in the near vicinity of the changing unit.
- Always leave your product clean and dry. Wipe away any spillage straight away. Your product can be cleaned with a damp cloth. Never use harsh abrasives, bleach or strong detergents
- Before use, ensure the dresser is on a stable, level surface.
- Do not allow children to climb on the dresser.
- Never use the dresser if any parts are broken or missing.
- Never pivot or drag the dresser on its feet, the dresser must always be lifted by at least two people when moved.
- A changing mattress is not supplied with this product. We recommend that you only use a Mamas & Papas changing mattress with your dresser. Lay the changing mattress on the changing surface, within the retaining rails.
- The dresser changer must be fixed to the wall for safe use and the fastenings used should be appropriate to the wall.
- Maximum weight of the child: 11kg.
- This product conforms to BS EN 12221:2008 + A1:2013

ES



ADVERTENCIA:

- NO DEJE SÓLO LA NIÑO. La seguridad de su hijo es su responsabilidad
- Para evitar vuelcos, este producto debe utilizarse con el accesorio para fijación a pared suministrado
- Este producto está diseñado para niños desde el nacimiento hasta 11 kg (aproximadamente 12 meses).
- Compruebe regularmente que todos los herrajes y tornillos están correctamente apretados y que no están dañados. Si hay tornillos flojos, éstos pueden pillar partes del cuerpo o la ropa con el consiguiente riesgo de estrangulamiento.
- No use piezas de repuesto no recomendadas o suministradas por Mamas & Papas.
- No ponga el producto cerca de chimeneas ni de otras fuentes de calor fuerte como fuegos eléctricos o de gas.
- Deje siempre el producto limpio y seco. Limpie cualquier suciedad con un trapo inmediatamente. Puede limpiar el producto con un trapo húmedo. No utilice nunca detergentes fuertes, abrasivos o lejía.
- Antes de usar, asegúrese de que el mueble cambiador se encuentra sobre una superficie llana y estable.
- No permita que los niños se suban al mueble cambiador.
- No use nunca el mueble cambiador si alguna de las piezas está rota o si falta alguna pieza.
- Nunca haga girar ni arrastre el mueble cambiador sobre sus patas. Para moverlo, al menos dos personas deben levantarlo.
- Este producto no incluye colchoneta. Recomendamos que use únicamente una colchoneta Mamas & Papas con este mueble cambiador. Ponga la colchoneta sobre la superficie dentro de los railes de contención.
- Se debe sujetar el mueble cambiador a la pared para un uso seguro. Las sujeciones deben ser apropiadas para la pared.
- Peso máximo del niño: 11 kg
- Este producto es conforme a la EN 12221:2008 + A1:2013

FR



AVERTISSEMENT! / MISE EN GARDE!

- NE LAISSEZ PAS LA ENFANT SANS SURVEILLANCE. La sécurité de votre enfant relève de votre responsabilité.
- Afin d'éviter le retournement, ce produit doit être utilisé avec le dispositif de fixation au mur
- Vérifiez régulièrement que toutes les fixations et les vis sont bien serrées et ne sont pas abimées. Les vis desserrées peuvent pincer des parties du corps et de vêtements et présenter ainsi un risque de strangulation.
- Ce produit est destiné à des enfants depuis la naissance jusqu'à 11 kg (12 mois. environ).
- N'utilisez pas de pièces de rechange qui n'ont pas été recommandées ou fournies par Mamas & Papas.
- Ne posez pas votre produit à proximité de feux de cheminée ou d'autres sources de chaleur intense, comme des feux électriques ou au gaz.
- Maintenez constamment le produit en parfait état de propreté et sec. Essuyez immédiatement tout déversement accidentel. Entretien : Le produit peut être nettoyé au chiffon humide. N'utilisez jamais d'abrasifs, d'eau de Javel ou de détergents puissants.
- Avant utilisation, vérifiez que la commode à langer repose sur une surface stable et de niveau.
- Ne laissez pas vos enfants grimper sur la commode à langer.
- N'utilisez jamais la commode à langer si des parties sont cassées ou manquantes.
- Ne pivotez jamais la commode et ne la traînez jamais par les pieds : pour être déplacée, la commode à langer doit toujours être soulevée par au moins deux personnes.
- Un matelas à langer n'est pas fourni avec ce produit. Nous vous recommandons d'utiliser exclusivement un matelas à langer Mamas & Papas avec votre commode à langer. Posez le matelas à langer sur la surface à langer, entre les rails de retenue.
- La commode à langer doit être fixée au mur pour être utilisée en toute sécurité et les attaches utilisées doivent convenir au type de mur.
- Poids maximum de l'enfant : 11 kg.
- Ce produit est conforme à EN 12221:2008 + A1:2013

D



WARNUNG:

- LASSEN SIE DAS KIND NIEMALS UNBEAUFICHTIGT. Für die Sicherheit Ihres Kindes sind SIE verantwortlich.
- Um ein Umkippen zu vermeiden muss dieses Produkt mit der zur Verfügung gestellten Wandbefestigung verwendet werden
- Dieser Produkt ist für Kinder von 0 bis 11 kg (ca. 12 Monaten) vorgesehen.
- Überprüfen Sie regelmäßig, dass alle Befestigungen und Schrauben korrekt angezogen und unbeschädigt sind. An lockeren Schrauben können Körperteile und Kleidung hängen bleiben und ein Strangulationsrisiko darstellen.
- Verwenden Sie keine Ersatzteile, die nicht von Mamas & Papas empfohlen oder geliefert wurden.
- Stellen Sie Ihr Produkt nicht in der unmittelbaren Nähe von offenem Feuer oder anderen intensiven Wärmequellen - wie z. B. Elektro- oder Gasöfen - auf.
- Achten Sie darauf, dass Ihr Produkt immer sauber und trocken ist. Verschüttete Flüssigkeiten müssen immer sofort abgewischt werden. Ihr Produkt kann mit einem feuchten Tuch gereinigt werden. Verwenden Sie weder Bleichmittel noch aggressive Scheuermittel oder starke Reinigungsmittel.
- Stellen Sie vor der Verwendung sicher, dass sich die Wickelkommode auf einer stabilen, waagerechten Oberfläche befindet.
- Lassen Sie Ihr Kind nicht auf die Wickelkommode klettern.
- Verwenden Sie die Wickelkommode nicht, wenn Teile defekt sind oder fehlen.
- Vermeiden Sie es, die Wickelkommode auf ihren Füßen zu ziehen oder zu drehen. Um die Wickelkommode zu versetzen, muss sie immer von zwei Personen angehoben werden.
- Eine Wechselmatratze gehört nicht zum Lieferumfang dieses Produkts. Wir empfehlen, die Wickelkommode zusammen mit einer Wechselmatratze von Mamas & Papas zu verwenden. Legen Sie die Wechselmatratze innerhalb der Halteschienen auf die Oberfläche.
- Zur sicheren Verwendung muss die Wickelkommode mit Hilfe von geeigneten Befestigungsmaterialien an der Wand befestigt werden.
- Das maximale Gewicht des Kindes beträgt 11kg.
- Dieses Produkt entspricht der Norm EN 12221:2008. + A1:2013

IT



AVVERTENZA:

- NON LASCIARE IL BAMBINO INCUSTODITO. Il genitore è responsabile della sicurezza del bambino.
- Per impedire che si ribalti, questo prodotto deve essere usato con il dispositivo per attacco a parete fornito.
- Mezzo adatto ai bambini dalla nascita fino a 11 kg (circa 12 mesi).
- Verificare regolarmente che tutti gli elementi di fissaggio e le viti siano correttamente serrati e in buone condizioni. Le viti allentate possono provocare lesioni sul corpo e sui vestiti del bambino, con il rischio di strangolamento.
- Non usare componenti di ricambio che non siano raccomandati o forniti da Mamas & Papas.
- Non posizionare il prodotto nelle vicinanze di fiamme o altre fonti di calore quali radiatori, fornelli elettrici o a gas.
- Mantenere sempre il prodotto pulito e asciutto. Eliminare immediatamente eventuali liquidi. Pulire con un panno umido. Non applicare mai sbiancanti, candeggina o detersivi abrasivi.
- Prima dell'uso, verificare che il fasciatoio sia in posizione stabile e orizzontale.
- Non consentire al bambino di arrampicarsi sul fasciatoio.
- Non usare mai il fasciatoio qualora vi fossero componenti mancanti o danneggiati.
- Non ruotare mai o trascinare il fasciatoio facendo leva sui piedini, ma sollevarlo sempre con l'aiuto di almeno un'altra persona per spostarlo.
- Il prodotto non comprende il materassino. Si raccomanda di utilizzare esclusivamente un materassino Mamas & Papas con questo fasciatoio. Posizionare il materassino sull'apposito piano, all'interno delle guide di blocco.
- Per la massima sicurezza, fissare il fasciatoio alla parete; verificare che gli elementi di fissaggio siano idonei per la parete utilizzata.
- Peso massimo del bambino: 11kg.
- Prodotto conforme alla norma EN 12221:2008 + A1:2013

NL



WAARSCHUWING:

- LAAT UW KIND NIET ZONDER TOEZICHT ACHTER. De veiligheid van uw kind is uw verantwoordelijkheid.
- Om te voorkomen dat dit product omkantelt, moet het worden gebruikt met de bijgeleverde muurbevestiging.
- Deze product is bedoeld voor kinderen vanaf de geboorte tot 11 kg (ongeveer 12 maanden).
- Controleer regelmatig of alle onderdelen en schroeven stevig en goed bevestigd zijn en niet zijn beschadigd. Door losse schroeven kunnen delen van het lichaam en kleding bekneld raken met als gevolg het risico van wurging.
- Gebruik alleen vervangende onderdelen die door Mamas & Papas worden aanbevolen of geleverd.
- Plaats het product niet in de buurt van open vuur of andere sterke hittebronnen, zoals elektrische kachels of gaskachels.
- Laat het product altijd schoon en droog achter. Als er op het product gemorst is, maak het dan meteen schoon. Het product kan met een vochtige doek worden afgenomen. Gebruik geen agressieve schuur- of bleekmiddelen of andere sterke schoonmaakproducten.
- Plaats de commode voor gebruik op een stabiele, gelijke ondergrond.
- Laat kinderen niet op de commode klimmen.
- Gebruik de commode niet als een onderdeel is gebroken of ontbreekt.
- Versleep of draai de commode nooit op de poten. Gebruik bij het verplaatsen van de commode altijd minstens twee personen om deze op te tillen.
- Dit product wordt geleverd zonder aankleedkussens. We raden aan dat u voor uw commode alleen aankleedkussens van Mamas & Papas gebruikt. Plaats het aankleedkussen op het aankleedschap, binnen de opstaande randen.
- Om de commode veilig te kunnen gebruiken, moet deze aan de muur worden vastgezet. De bevestigingsmaterialen die u hiervoor gebruikt, moeten geschikt zijn voor de muur.
- Maximum gewicht van het kind: 11 kg.
- Dit product voldoet aan norm EN 12221:2008 + A1:2013

mamas & papas®

HD5 0RH, UK



mamasandpapas.com
mamasandpapas.ca
mamasandpapas.kr

UK T: +44 (0)345 268 2000

USA T: 1-800-490-0331

CAN T: 1-800-667-4111



[/mamasandpapasuk](#)
[/mamasandpapasusa](#)
[/mamasandpapasmaltaregion](#)
[/mamasandpapasmagyarorszag](#)



[@mamasandpapas](#)



[/user/mamasandpapasglobal](#)



[mamasandpapasblog.com](#)



[/mamasandpapas](#)



[/mamasandpapasuk](#)
[/mamasandpapasus](#)



[/+mamasandpapas](#)

[SC14]
Bunny & Clyde
Dresser Changer
Lot:
00417
Made in Poland
Mamas & Papas
HD5 0RH, UK

F_0239_0112_V3