

X2



1.5h



**Thank you for ordering from
Mamas & Papas.**

For over 30 years, we have been committed to creating a world of quality, individuality and style for parents around the world. At the very beginning we were inspired by our daughters — now we see them all grown up, with children of their own, helping us to share our passion for parenting to their generation of Mums and Dads. We hope you enjoy exploring our new collection and wish you a very warm welcome to our world.

We are committed to designing and developing products to the highest standards, for your family to enjoy and we welcome any feedback or comments you may have.

The Mamas & Papas Family.

**Gracias por elegir
Mamas & Papas.**

Durante más de 30 años, nuestro compromiso ha sido crear un mundo de calidad, individualidad y estilo para padres de todo el mundo. Al principio nos inspiraron nuestras propias hijas, que ahora son adultas y tienen sus propios hijos, y nos ayudan a compartir nuestra pasión por la paternidad con su generación de mamás y papás. Esperamos que disfruten descubriendo nuestra nueva colección y les damos una calurosa bienvenida a nuestro mundo.

Nos comprometemos a diseñar y elaborar productos de la mejor calidad, con el fin de que su familia los disfrute y nosotros recibamos las respuestas y comentarios que le puedan surgir.

La Familia Mamas & Papas.

**Merci d'avoir choisi
Mamas & Papas.**

Cela fait plus de 30 années que nous nous consacrons à créer un monde de qualité, d'individualité et de style pour les parents dans le monde entier. Au tout début, nous étions inspirés par nos filles — à présent celles-ci ont grandi, elles ont des enfants aussi et nous aident à partager avec vous notre passion de création en nous adressant à leur génération de mamans et de papas. Nous espérons que vous passerez un agréable moment à découvrir notre nouvelle collection et nous sommes heureux de vous accueillir dans notre monde.

Nous nous engageons à concevoir et à développer des produits de la plus haute qualité, pour le plaisir de votre famille et nous serions heureux de recevoir vos réactions et observations éventuelles.

La Famille Mamas & Papas.



für Mamas & Papas entschieden haben.

Seit über 30 Jahren entwickeln wir mit großem Engagement für Eltern in aller Welt Produkte, die für Qualität, Individualität und Stil stehen. Die erste Inspiration gaben uns unsere Töchter, die mittlerweile erwachsen sind, selbst Kinder haben und uns nun dabei helfen, die Mütter und Väter ihrer Generation mit unserer Begeisterung für Babyprodukte anzustecken. Wir hoffen, dass es Ihnen Spaß machen wird, sich unsere neue Kollektion anzusehen, und heißen Sie herzlich willkommen in unserer Welt.

Wir haben es uns zur Aufgabe gemacht, Produkte auf höchstem Niveau zu entwerfen, die Ihre Familie genießen kann. Daher freuen wir uns immer über Ihr Feedback oder Ihre Kommentare.

Die Mamas & Papas-Familie.

Grazie per aver scelto Mamas & Papas.

Da oltre 30 anni lavoriamo per creare un mondo di qualità, unicità e stile per i genitori di tutto il mondo. All'inizio abbiamo tratto ispirazione dalle nostre figlie; adesso che sono cresciute e hanno a loro volta dei figli, ci aiutano a far conoscere alla loro generazione di mamme e papà la nostra passione nel vivere l'esperienza di genitori. Ci auguriamo che apprezzerete la nostra nuova collezione e vi diamo un caloroso benvenuto nel nostro mondo

Il nostro impegno è quello di progettare e realizzare prodotti rispondenti agli standard più elevati per la vostra famiglia e saremo lieti di ricevere suggerimenti o commenti da parte vostra.

La famiglia di Mamas & Papas.

Hartelijk dank dat u voor een product van Mamas & Papas heeft gekozen.

Al meer dan 30 jaar zetten wij ons in om een wereld van kwaliteit, individualiteit en stijl te scheppen voor ouders verspreid over de hele aardbol. In het begin werden we geïnspireerd door onze eigen dochters. Nu die volwassen zijn en zelf kinderen hebben, helpen zij ons onze passie voor ouderschap te delen met vaders en moeders van hun eigen generatie. We hopen dat u onze nieuwe collectie met plezier zult verkennen en heten u van harte welkom in onze wereld.

Wij hopen dat u met uw gezin van onze producten zult genieten en mocht u feedback willen geven of andere opmerkingen hebben, dan horen we graag van u.

De Mamas & Papas Familie.



EN **IMPORTANT!**
RETAIN FOR FUTURE REFERENCE:
READ CAREFULLY

ES **¡IMPORTANTE!**
LEA ESTAS INSTRUCCIONES DETENIDAMENTE Y
GUÁRDELAS PARA FUTURA REFERENCIA

FR **IMPORTANT !**
VEUILLEZ LIRE CES CONSIGNES AVEC ATTENTION
ET LES CONSERVER POUR VOUS Y REPORTER
ULTÉRIEUREMENT

D **ACHTUNG!**
BITTE LESEN SIE SICH DIESE ANWEISUNGEN
SORGFÄLTIG DURCH UND BEWAHREN SIE SIE FÜR
ZUKÜNFTIGE VERWENDUNG AUF

IT **IMPORTANTE!**
LEGGERE ATTENTAMENTE QUESTE ISTRUZIONI E
CONSERVARLE COME RIFERIMENTO FUTURO

NL **BELANGRIJK!**
BEWAAR VOOR TOEKOMSTIGE REFERENTIE:
LEES DIT ZORGVULDIG DOOR

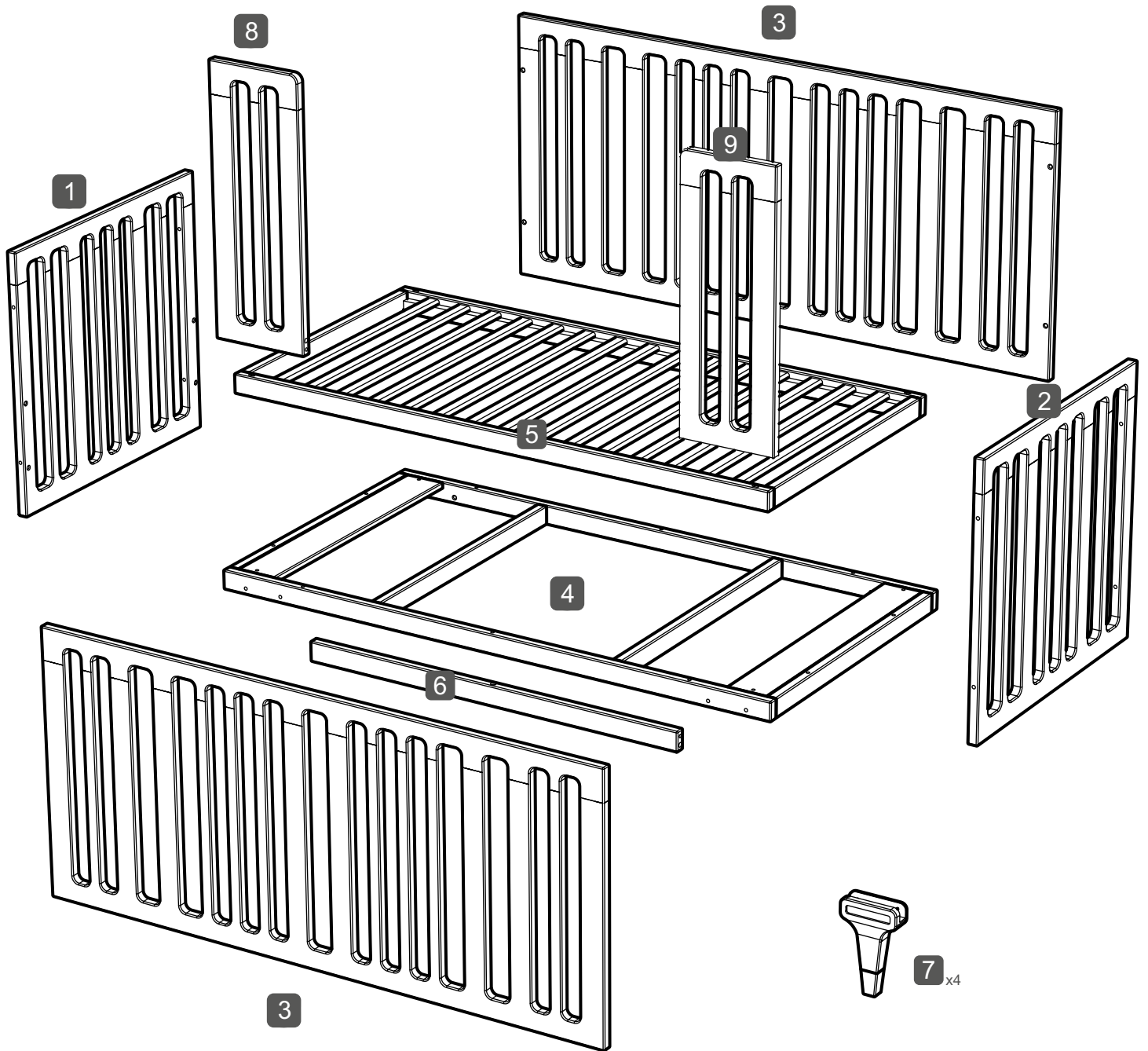
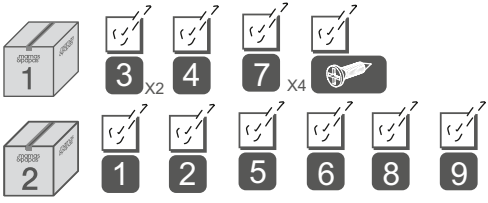

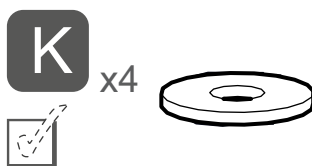
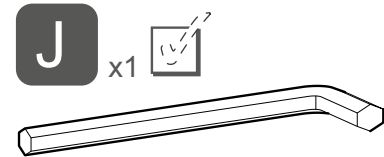
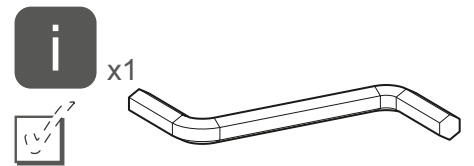
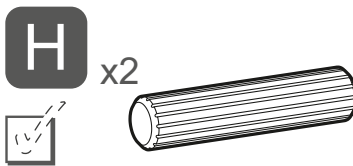
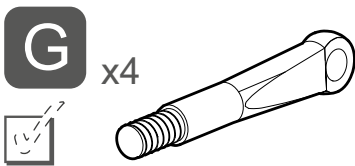
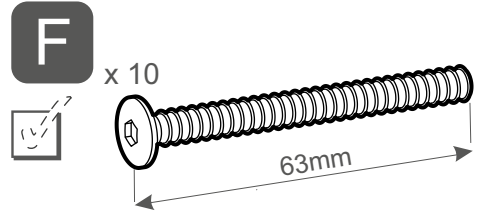
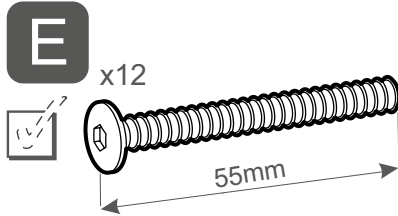
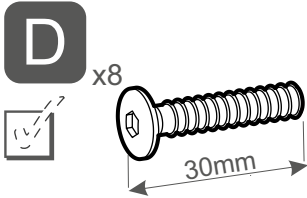
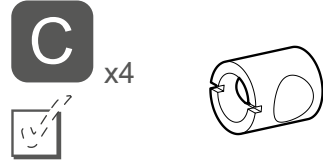
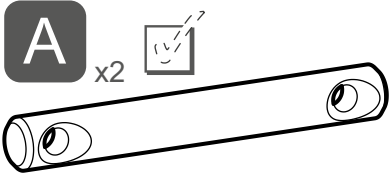
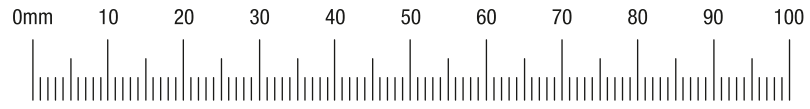

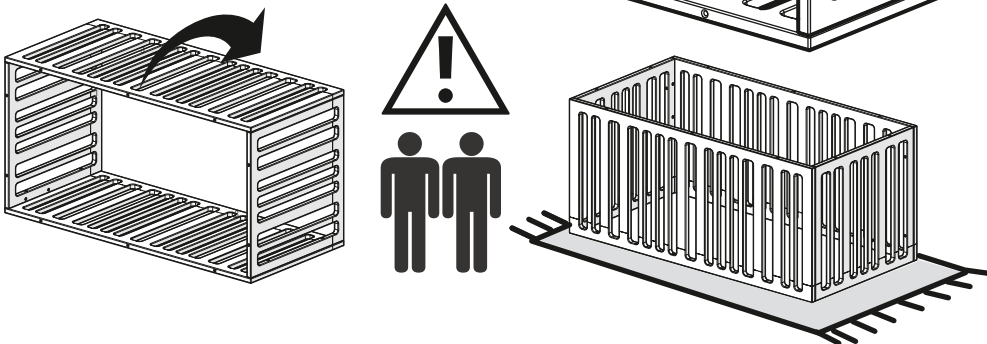
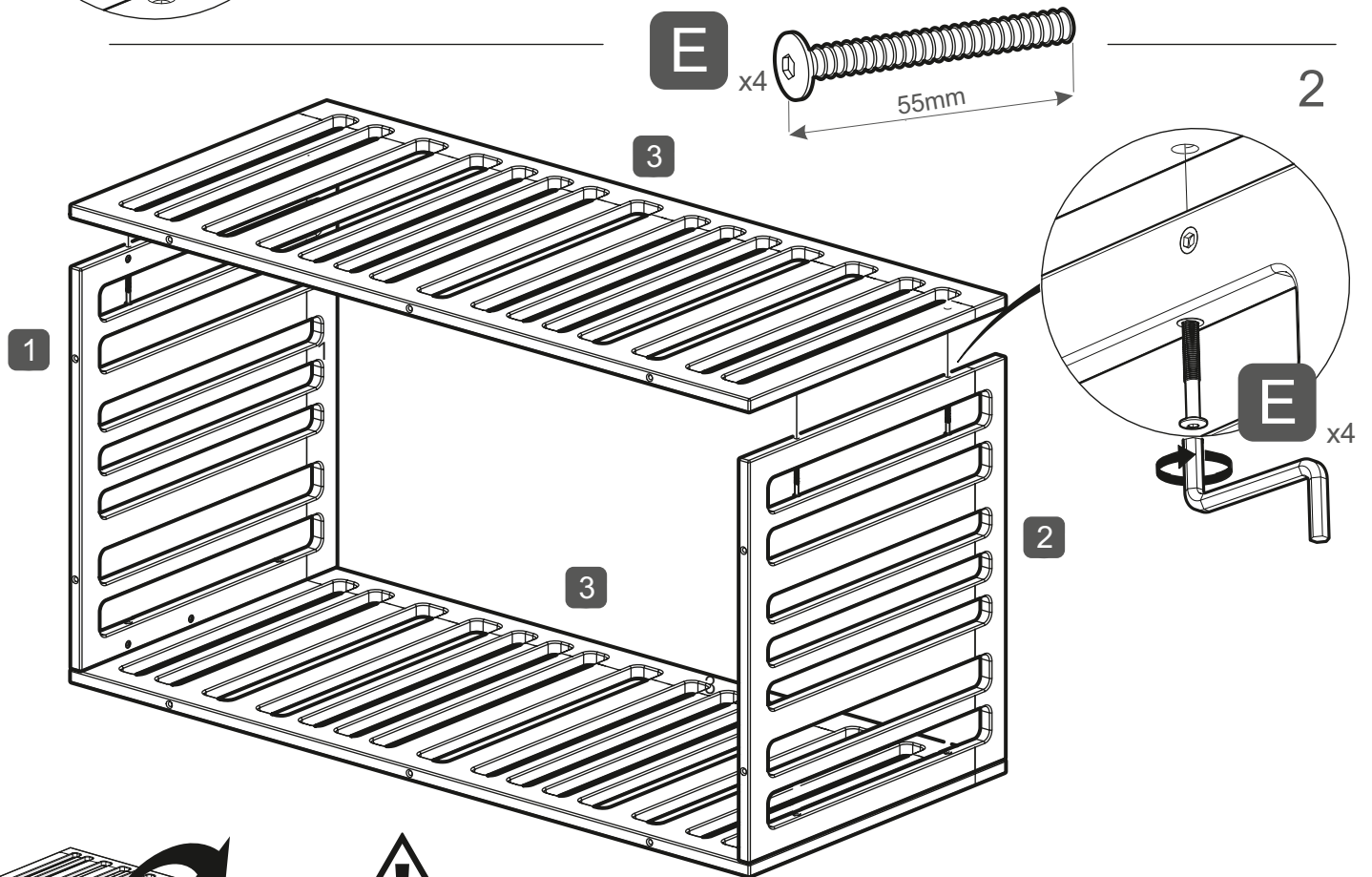
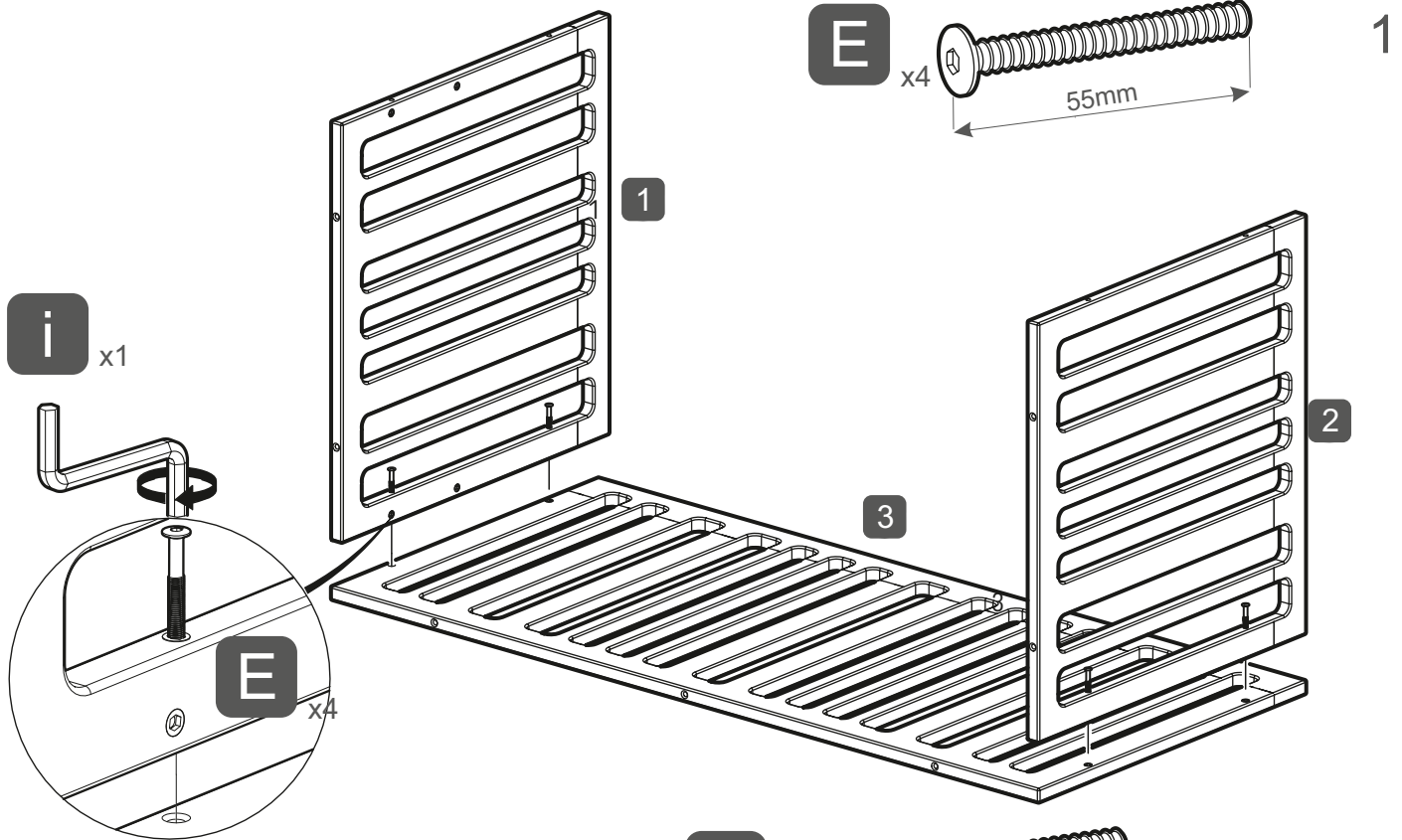

3

F

x 10

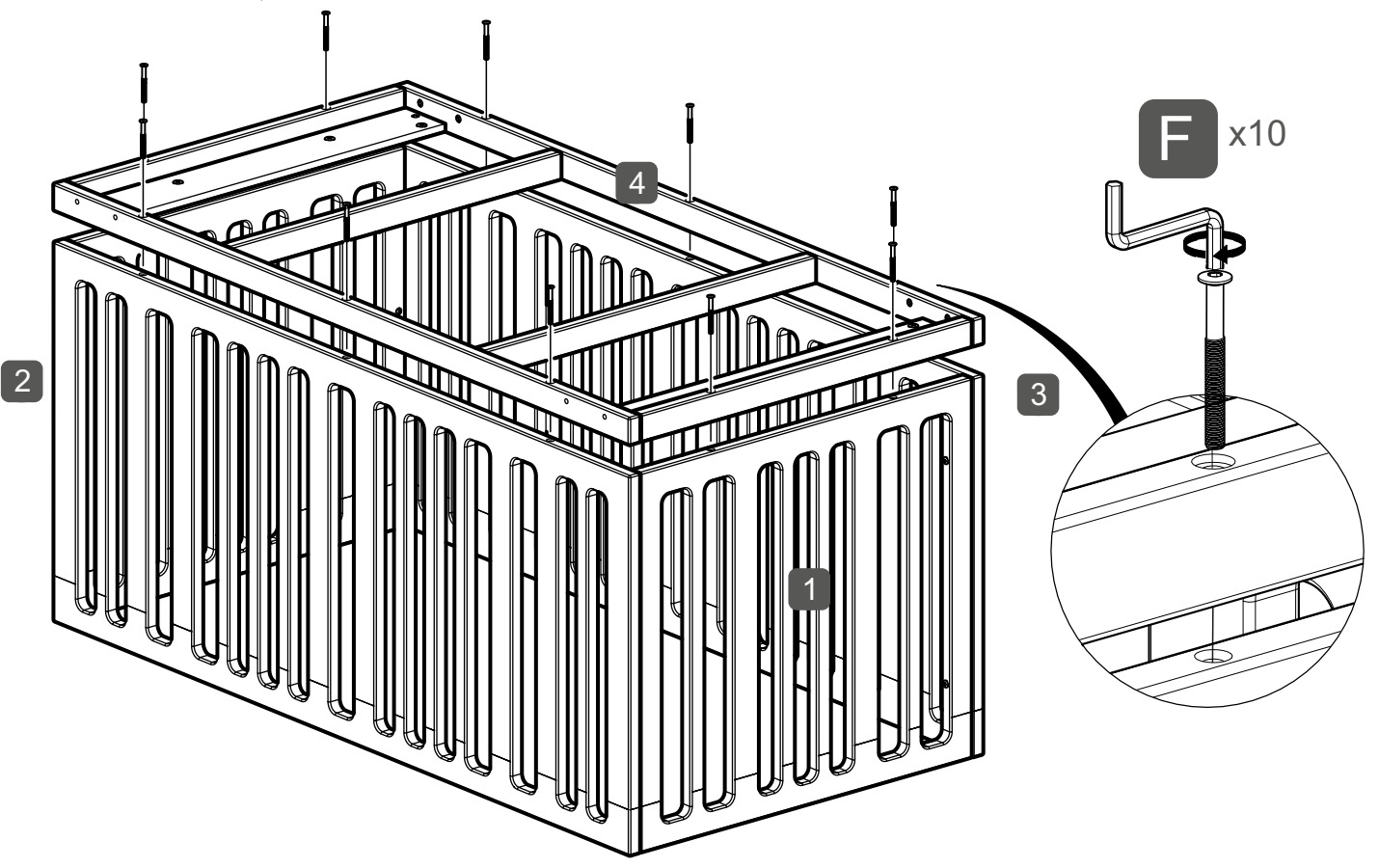
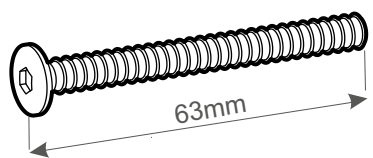

4

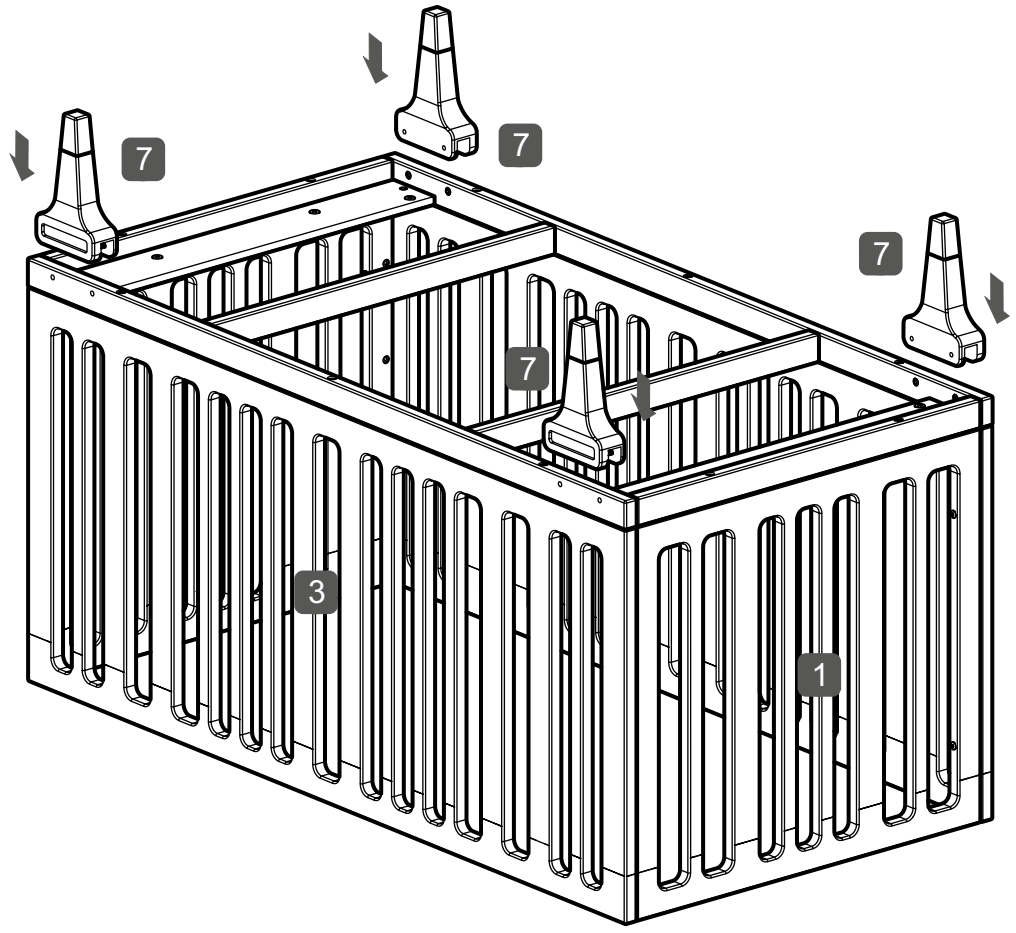

5

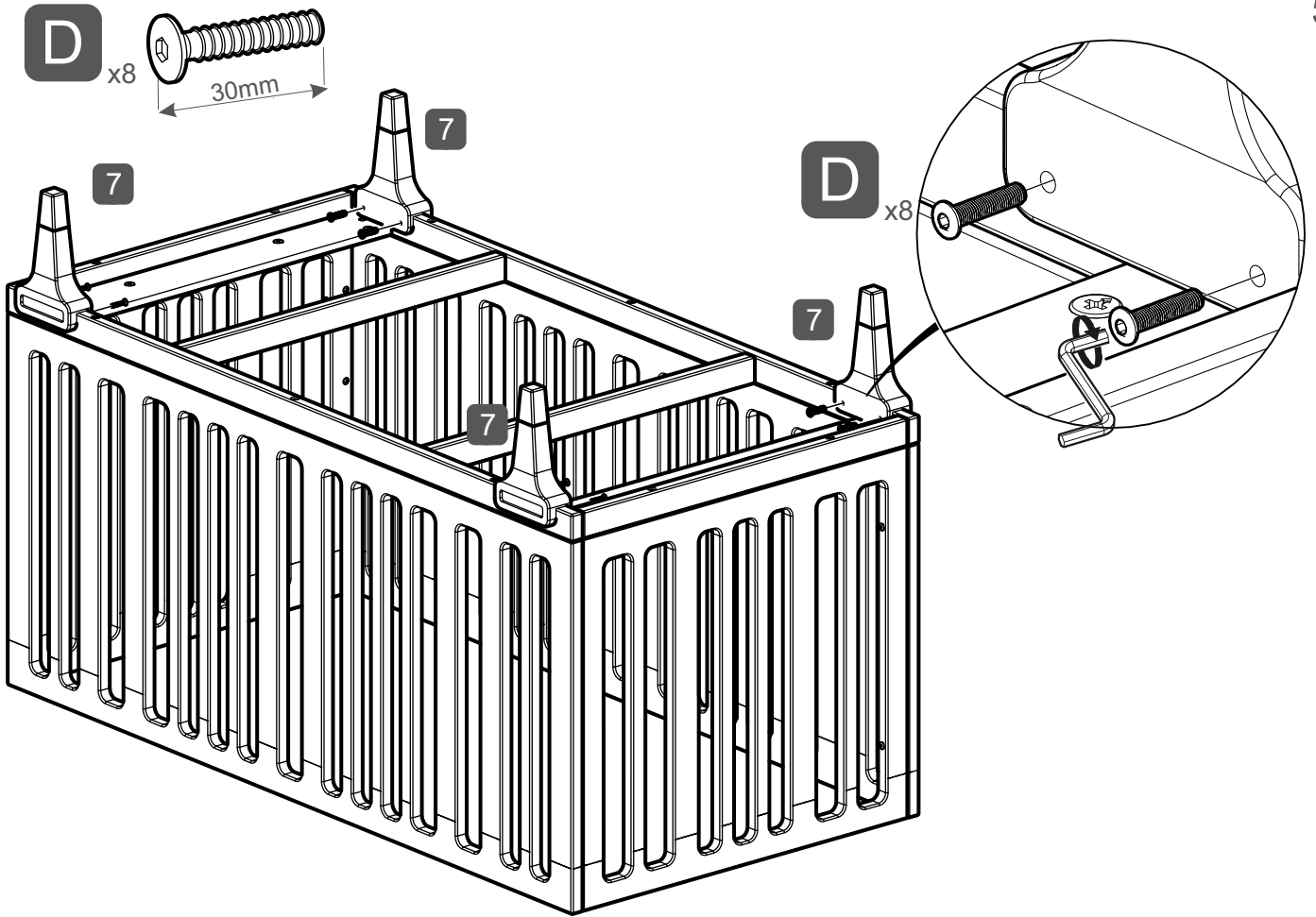

6

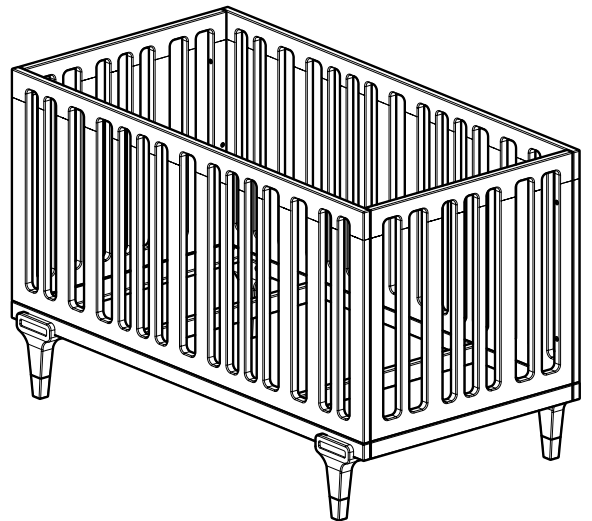
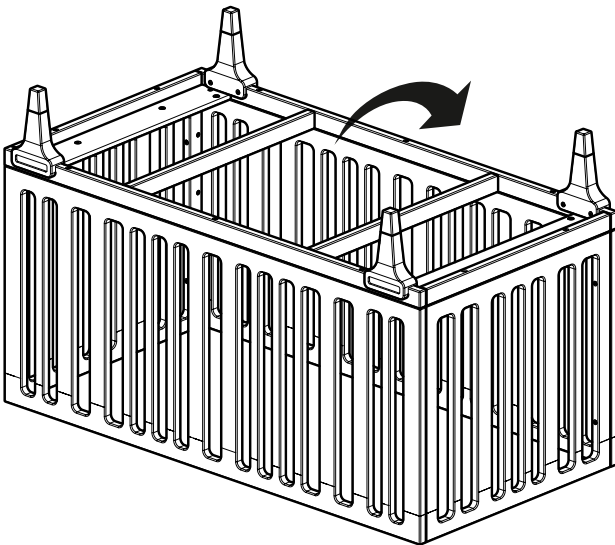
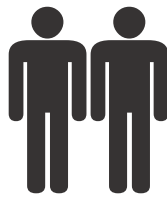

7

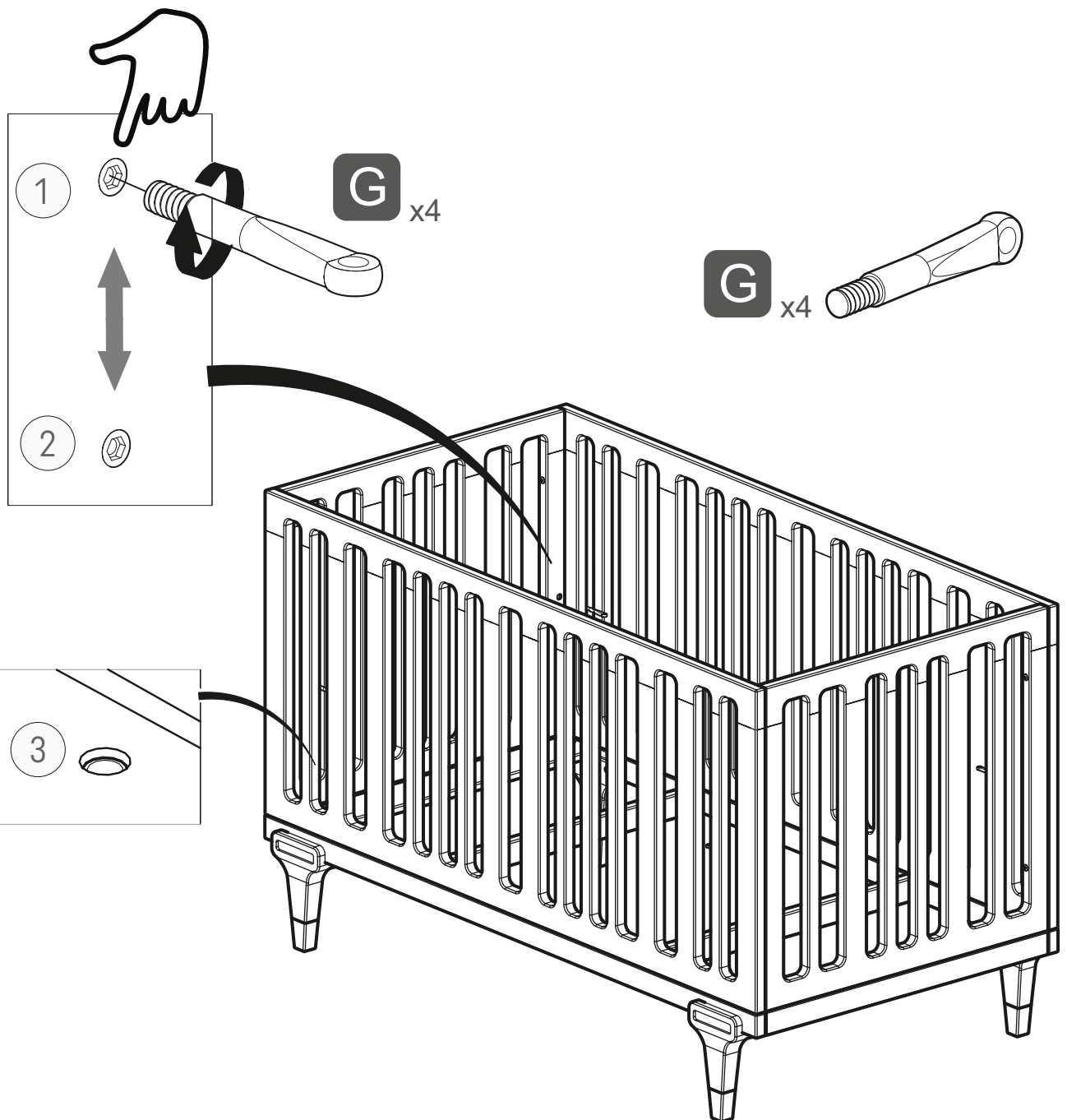
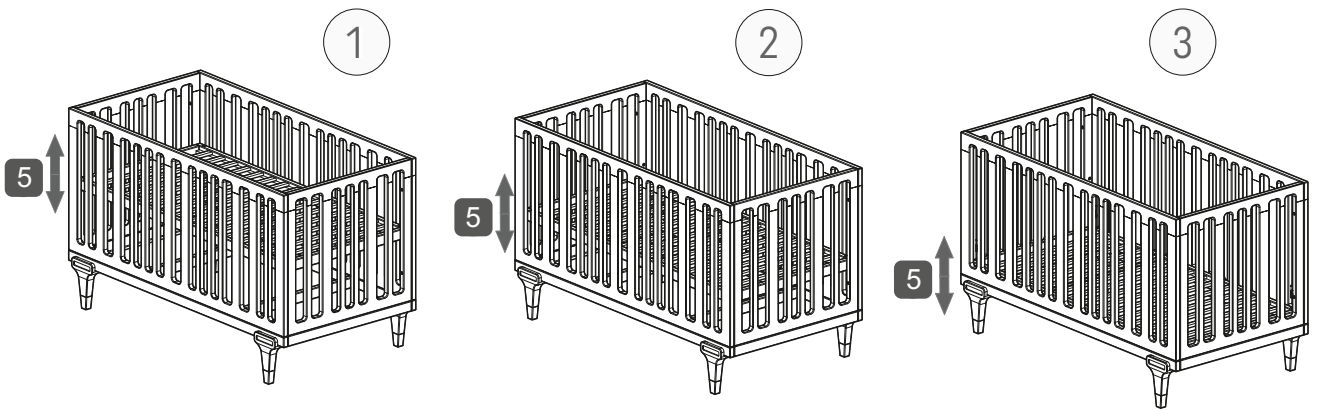



1

2

K x4



E x4

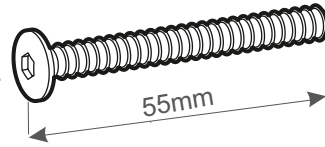

8

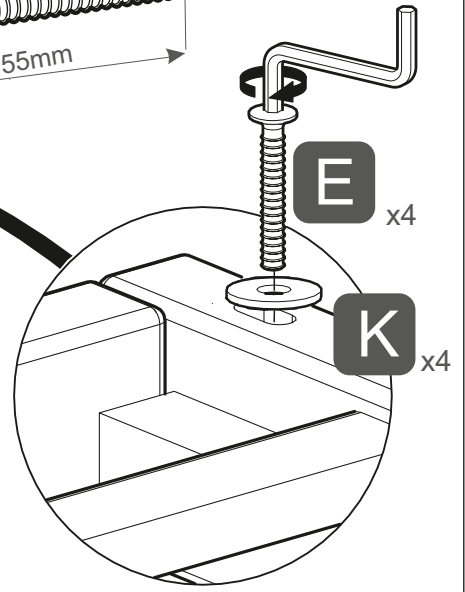
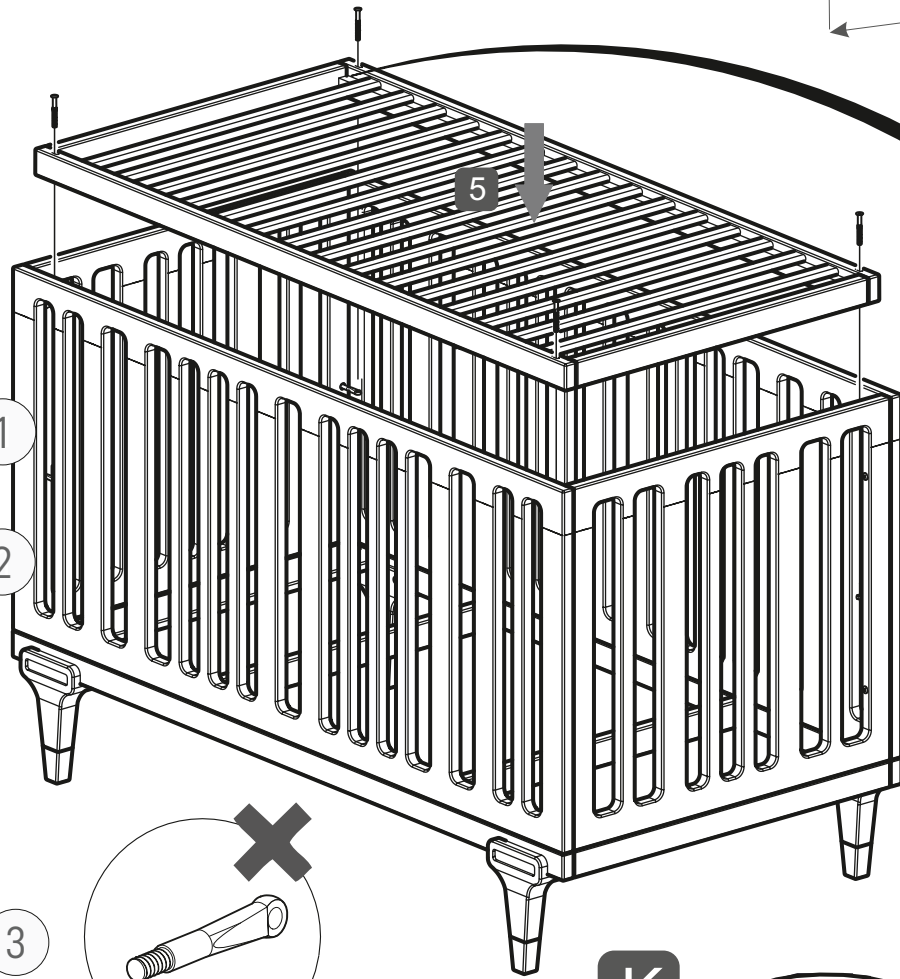

1

2

3

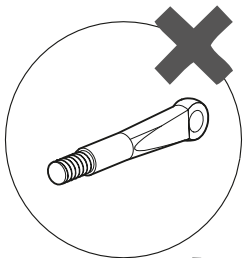

K x4



E x4

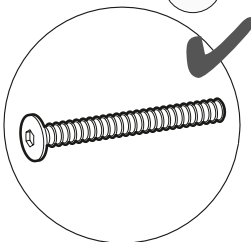
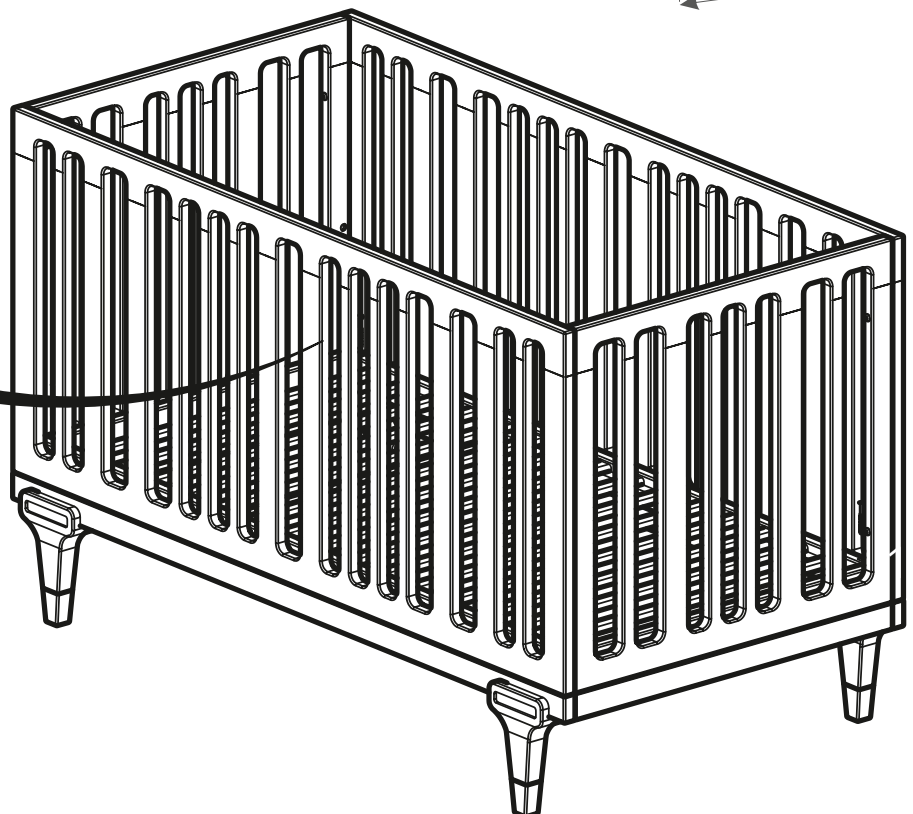
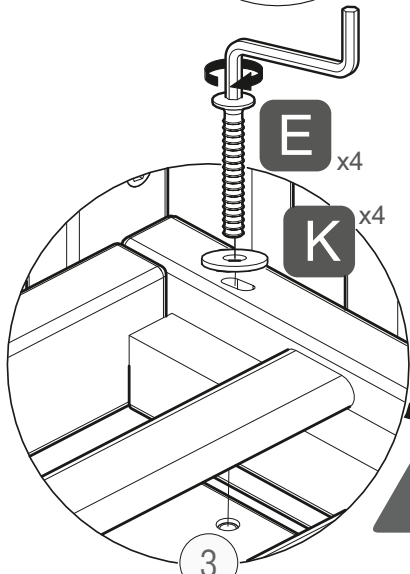
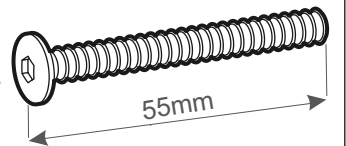

9

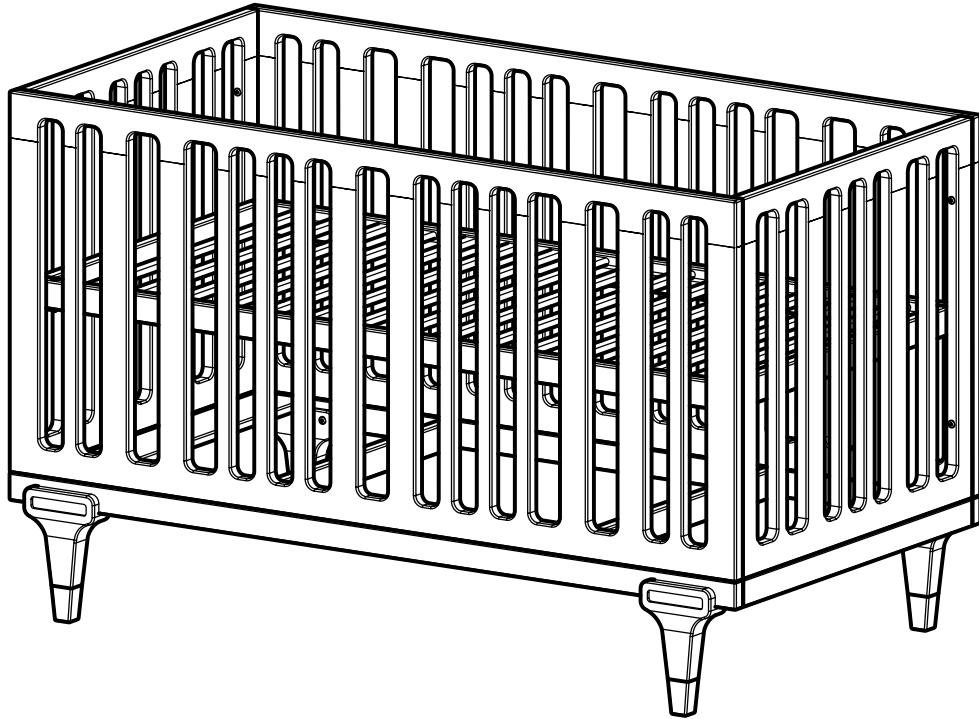

Finished

Concluido

Fini

Fertig

Finito

Voltooid

10

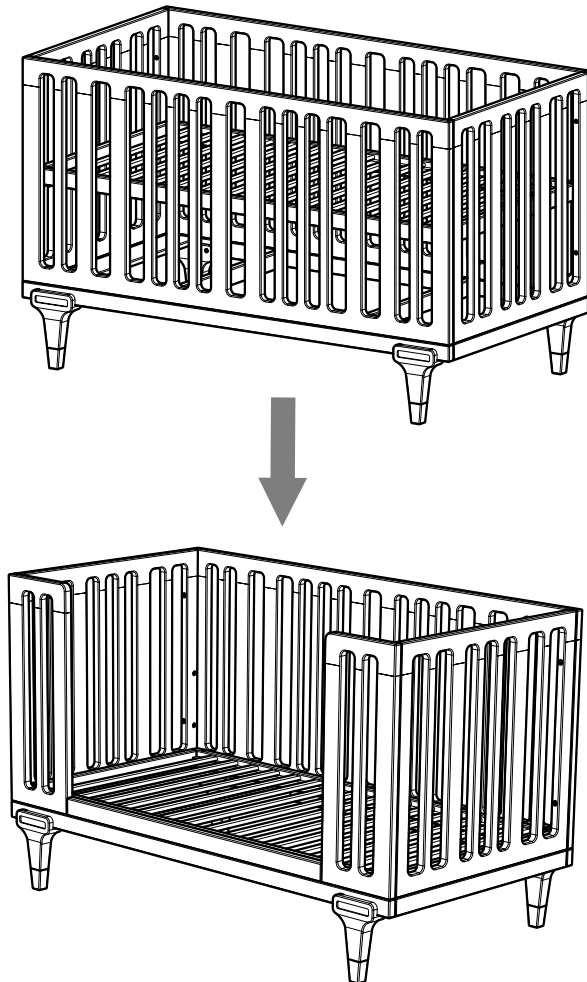

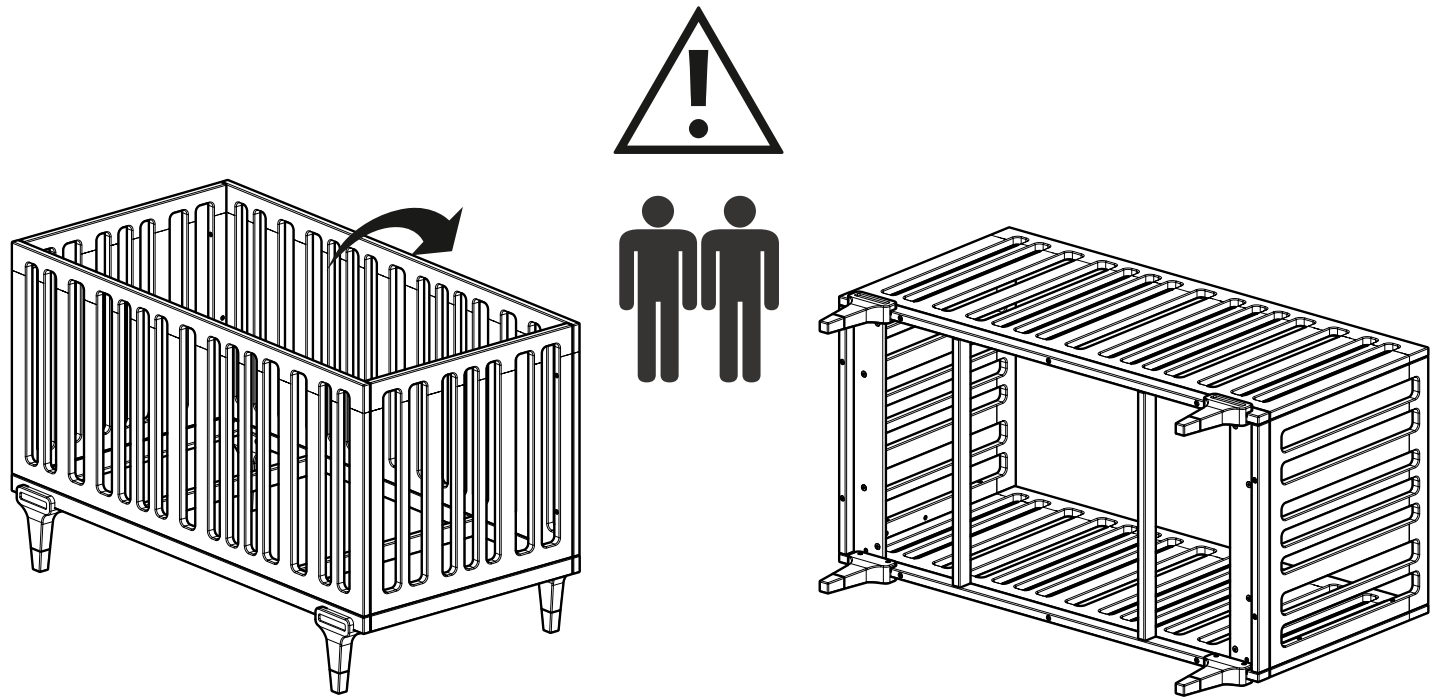
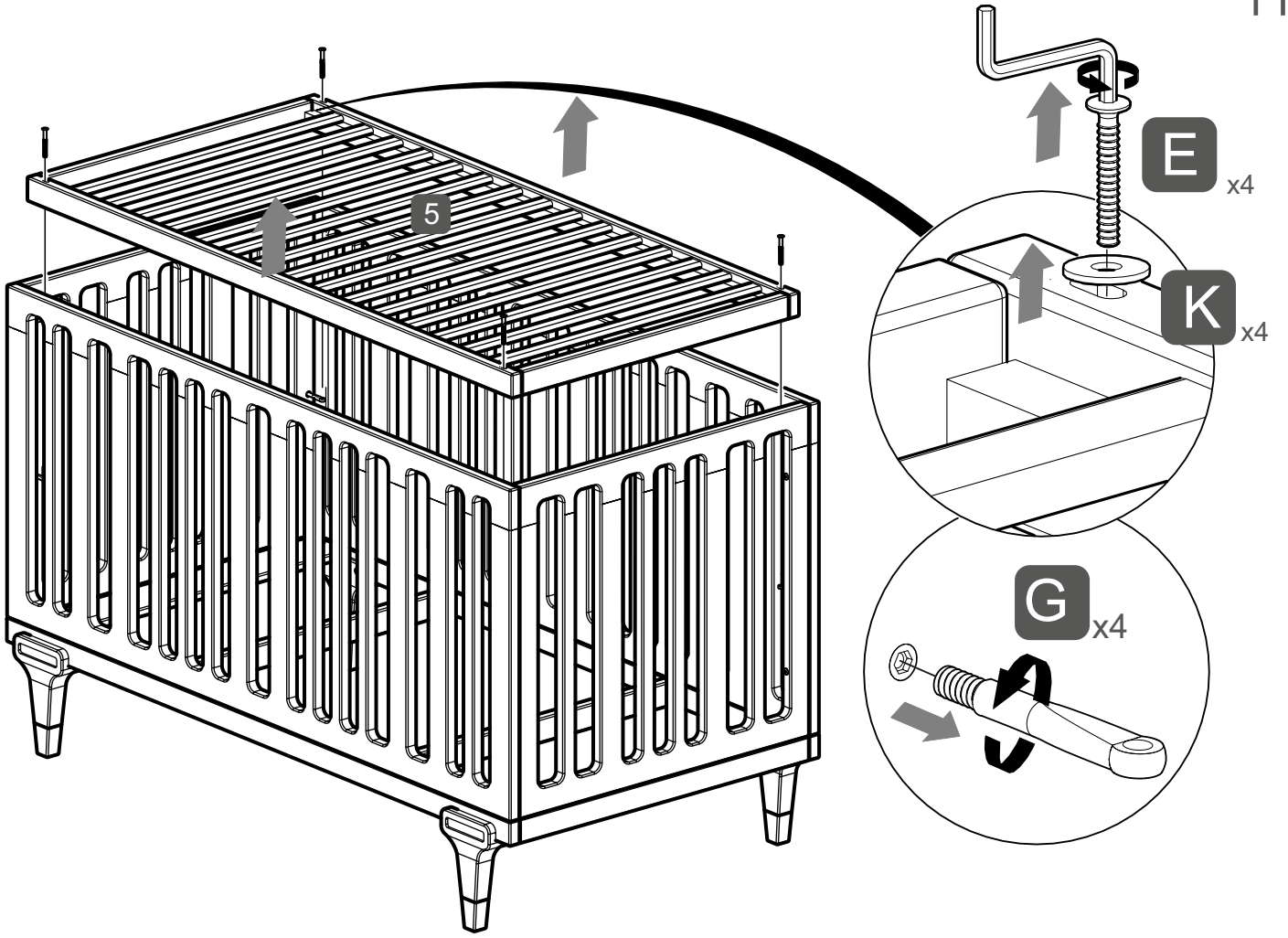

13

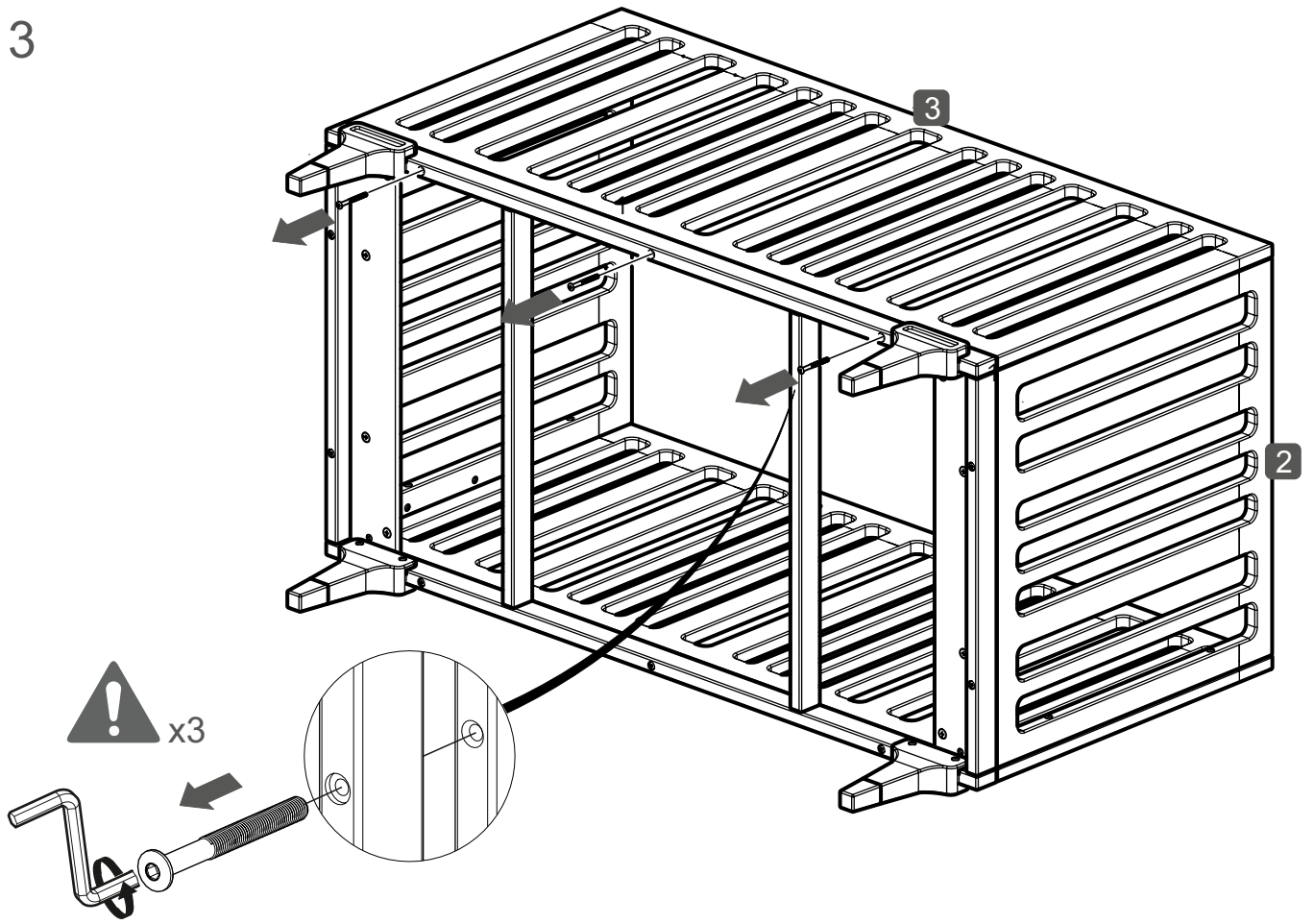

14

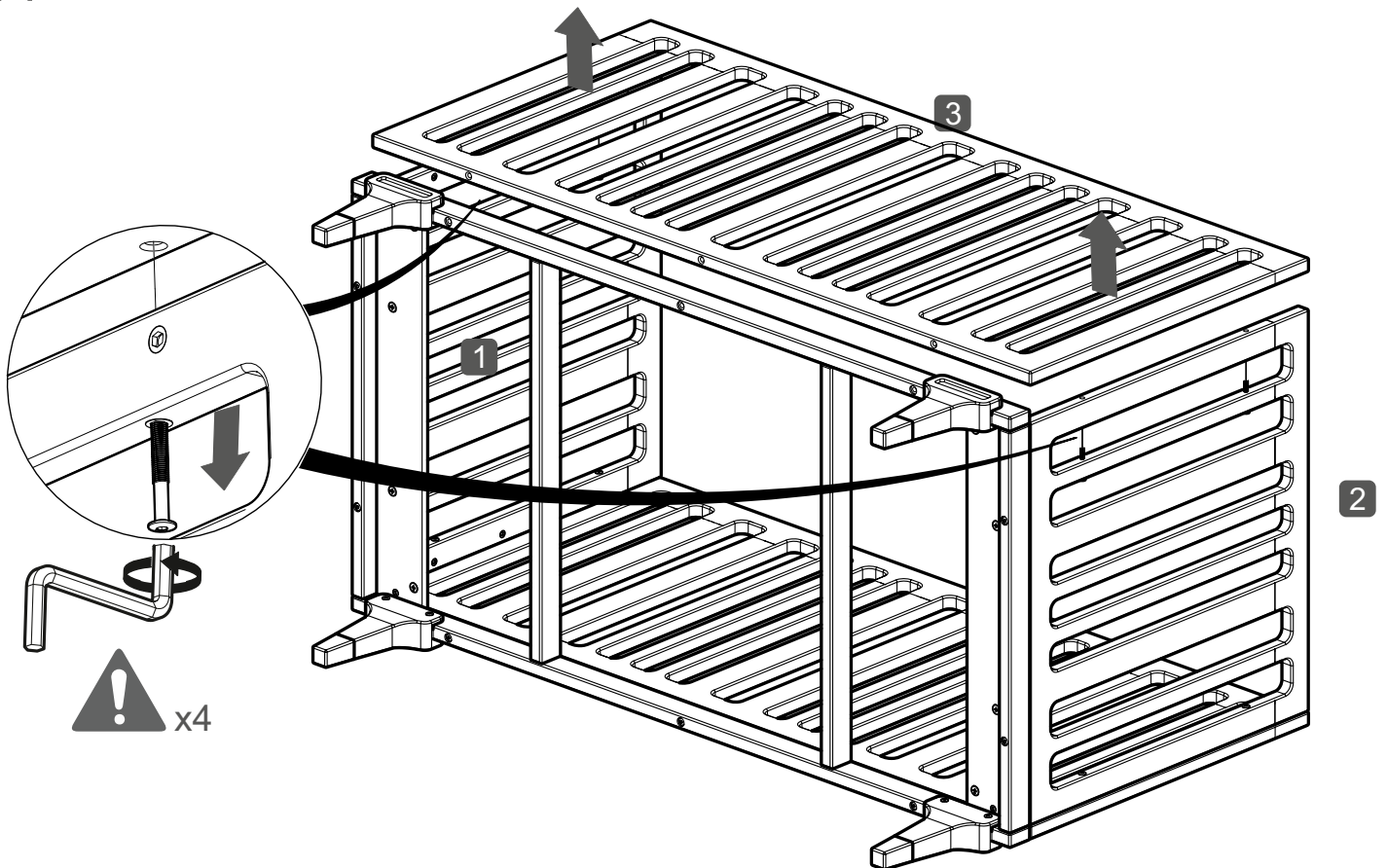

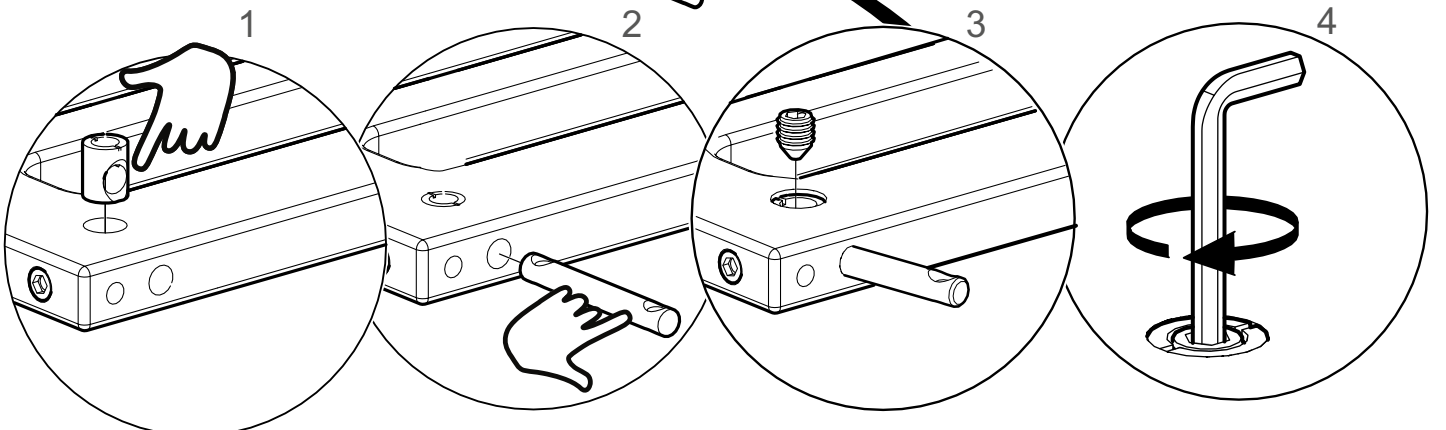
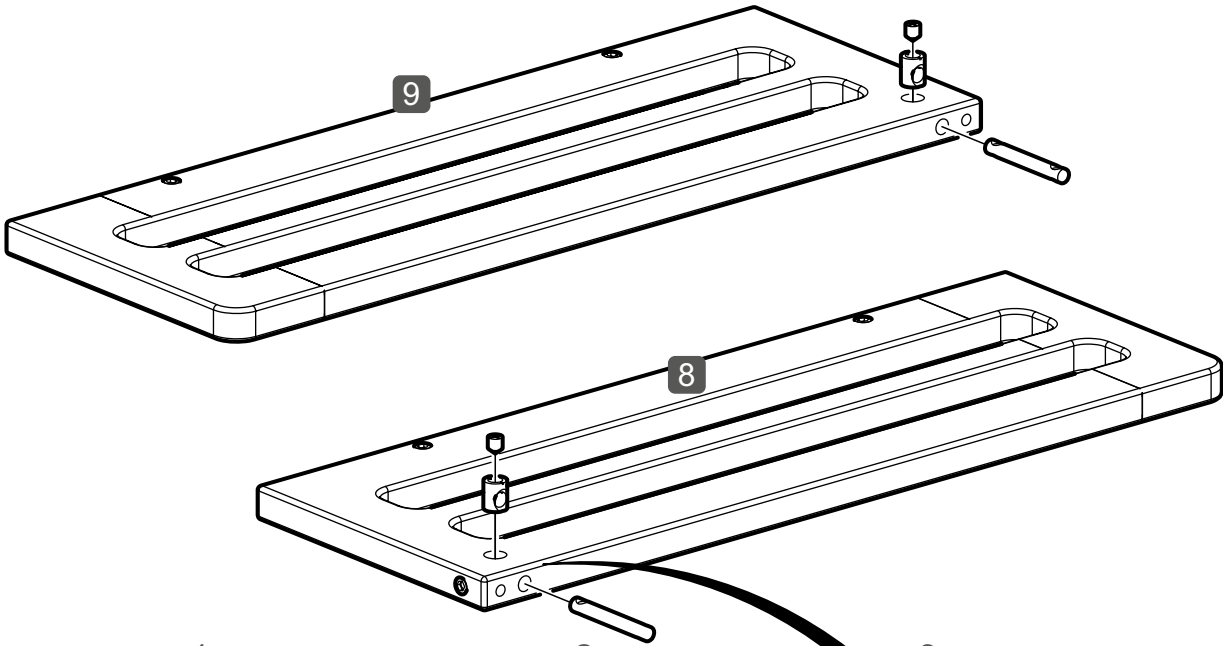
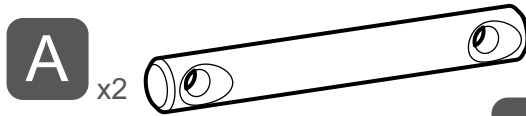
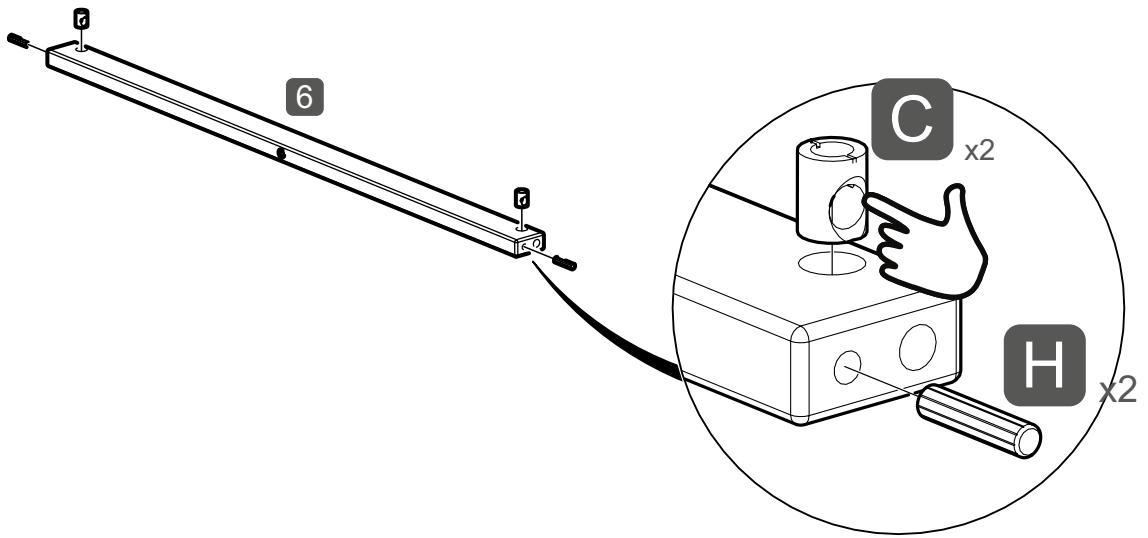
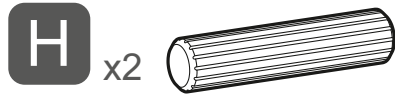

17

B x2



J x1

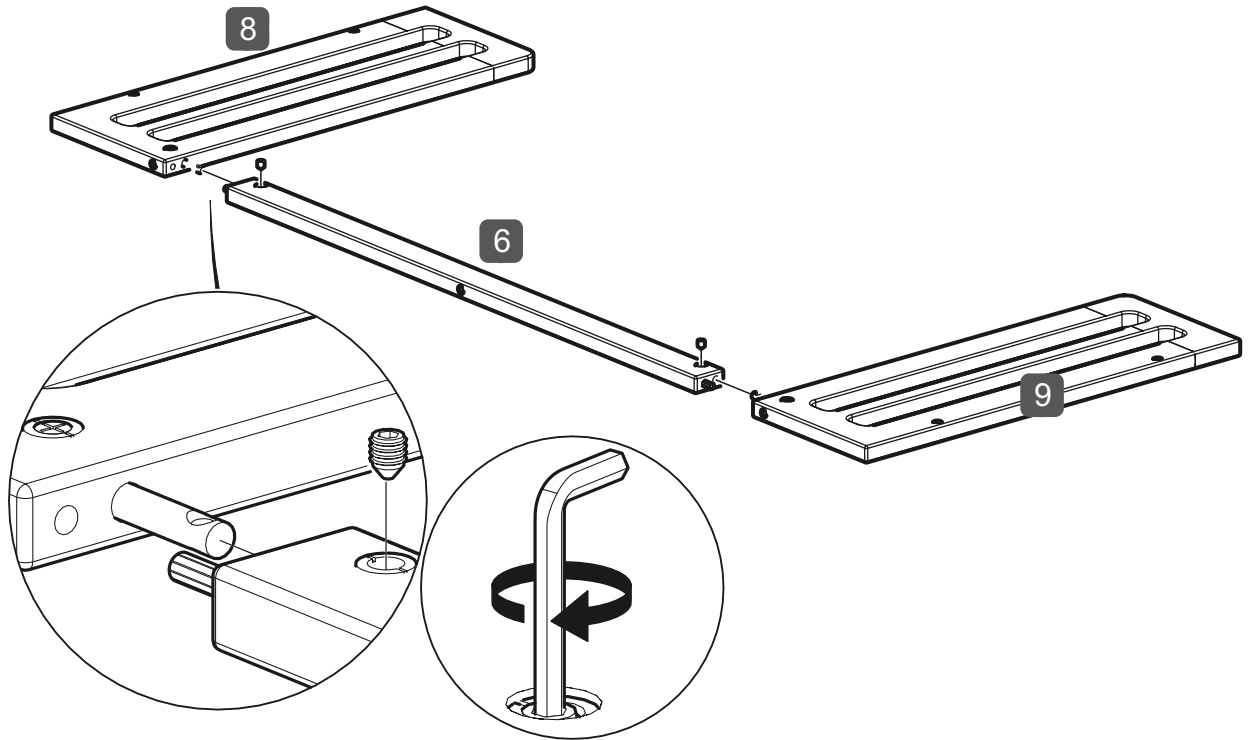

18

E x4

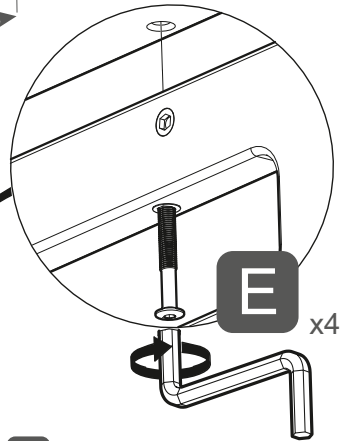
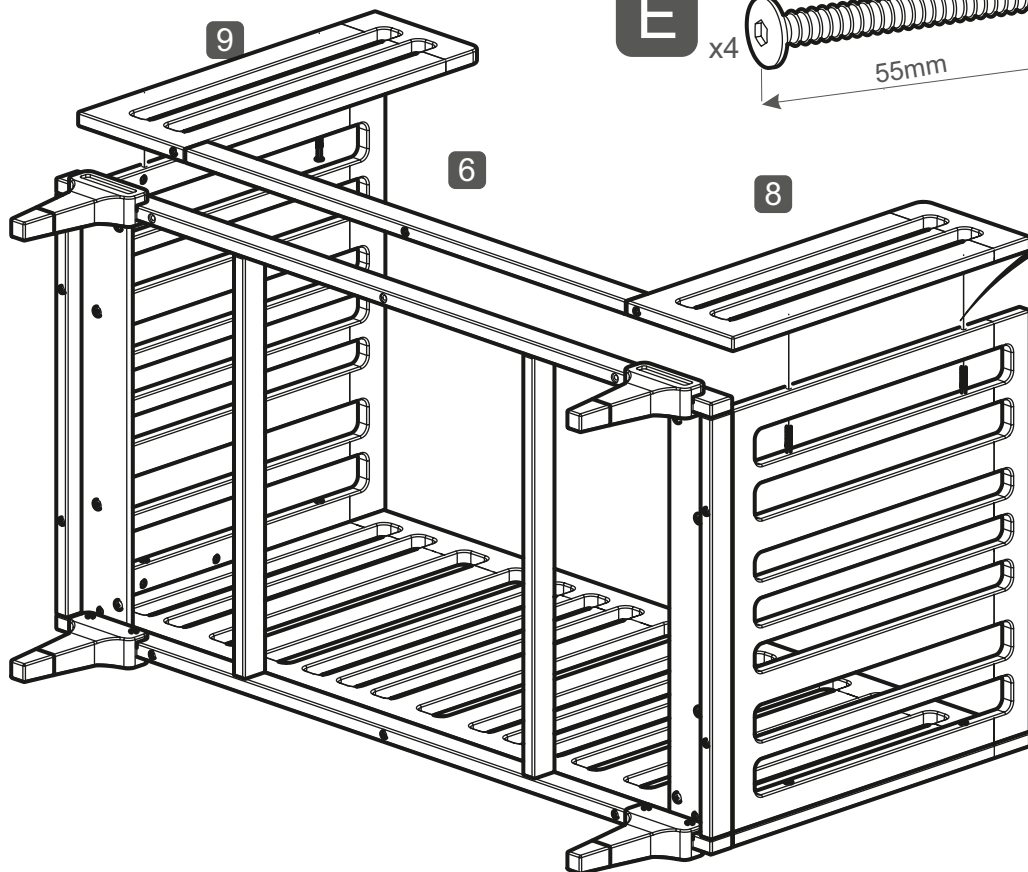
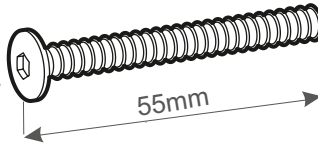

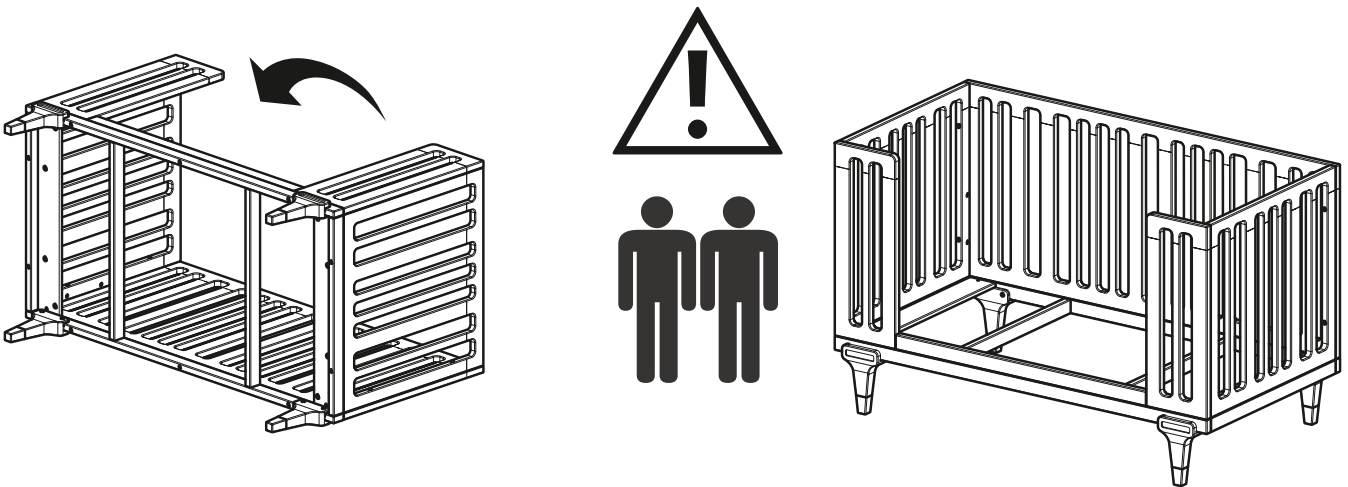
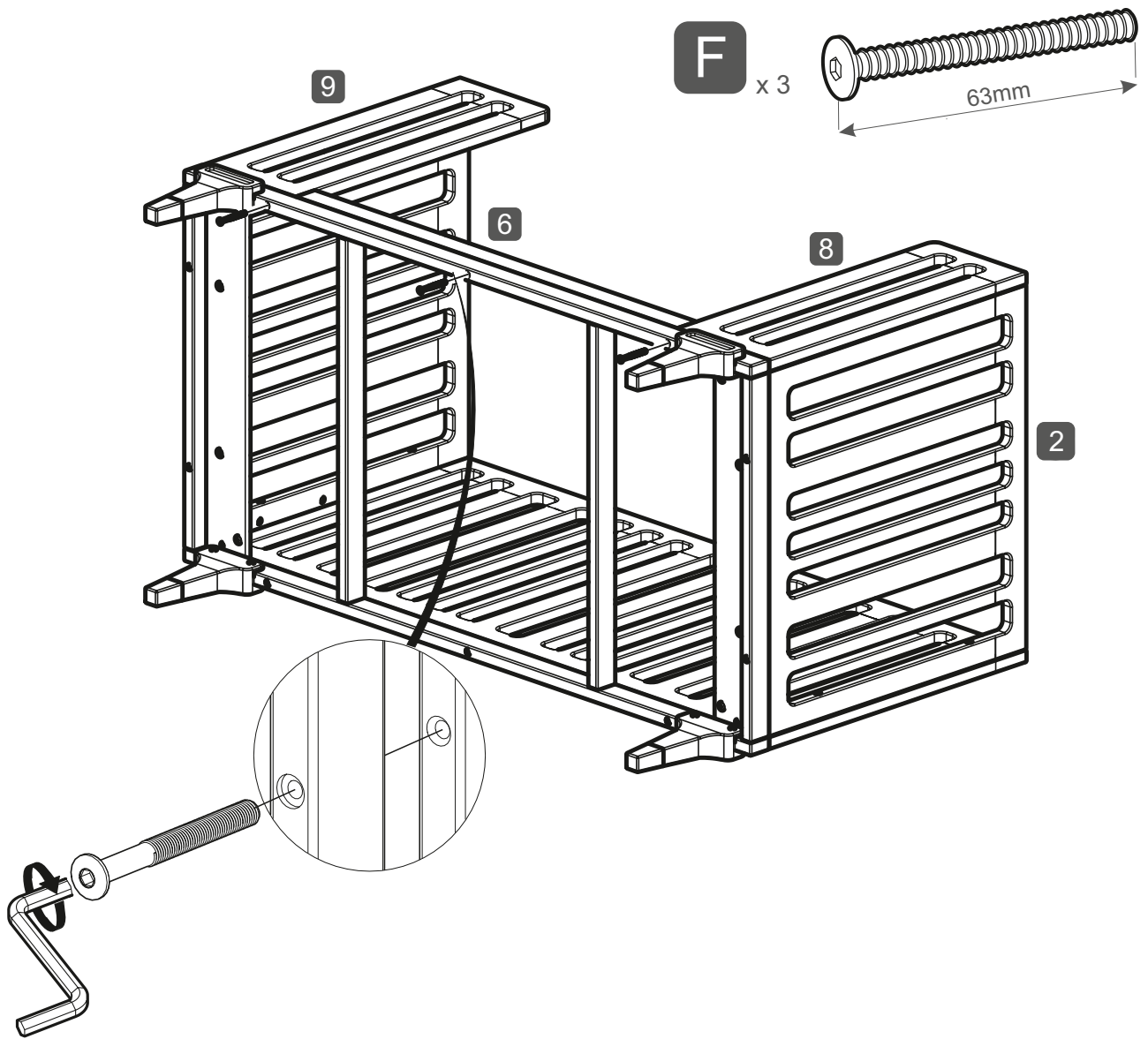

21

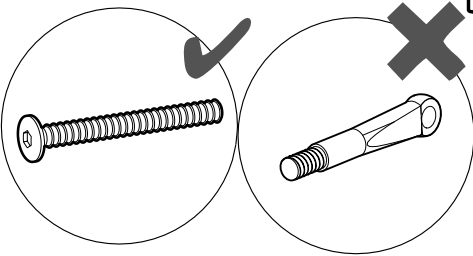
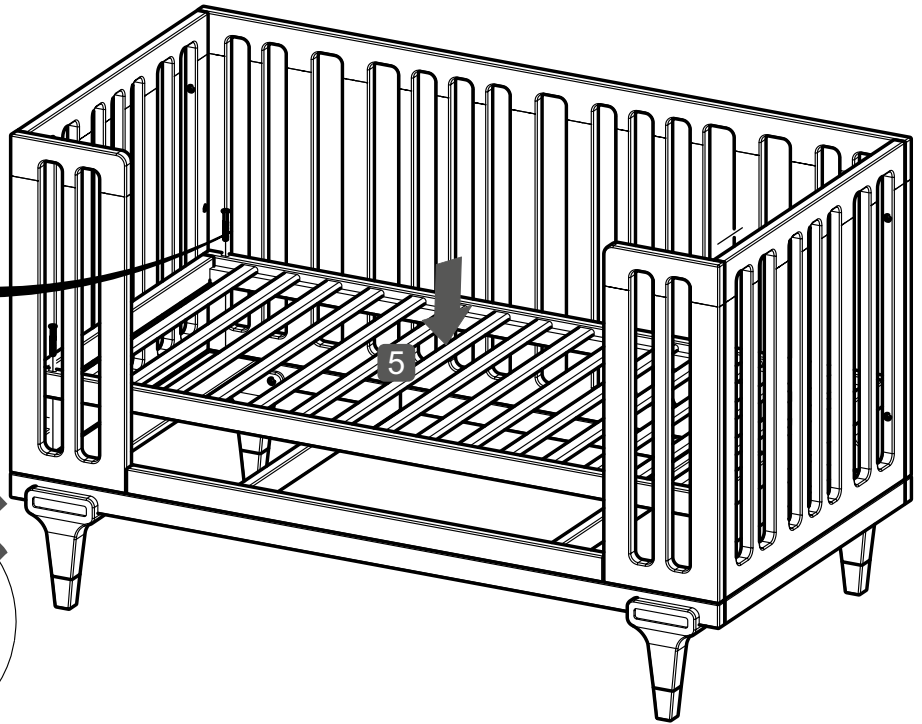
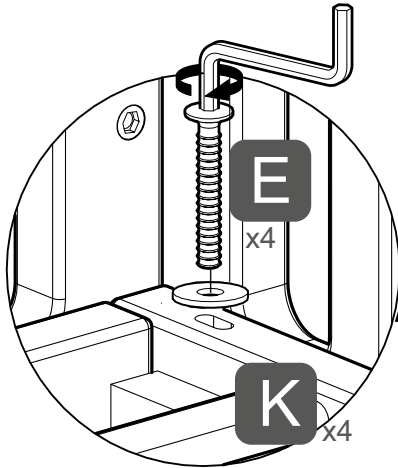
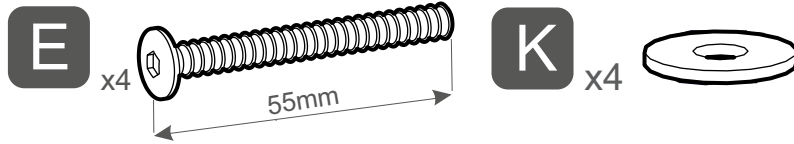

22

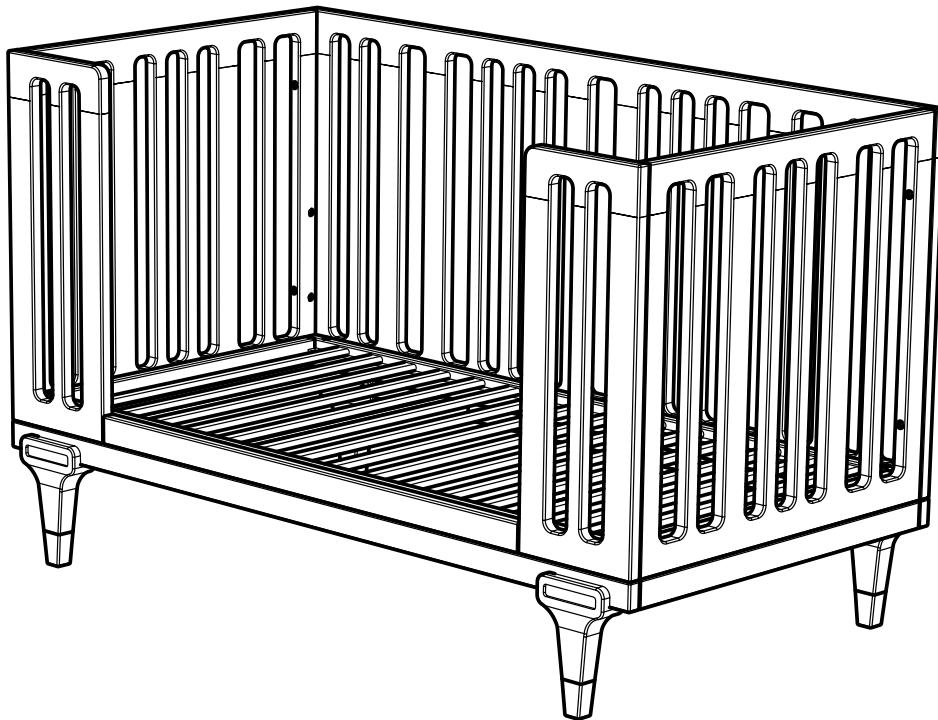

Finished

Concluido

Fini

Fertig

Finito

Voltooid

UK



WARNING:

- Do not use the cot if any part is broken, torn or missing and use only spare parts approved by the manufacturer.
 - Be aware of the risk of open fire and other sources of strong heat, such as electric bar fires, gas fires, etc. in the near vicinity of the cot.
 - Do not leave anything in the cot or place the cot close to another product, which could provide a foothold or present a danger of suffocation or strangulation, e.g. strings, blind/curtain cords etc.
 - Do not use more than one mattress in the cot.
 - Do not place this child's bed near heat sources, windows and other furniture.
 - Do not use this child's bed if any part is broken, torn or missing.
-
- The lowest position is the safest. Once your child is old enough to sit up unaided the base should be used in the lowest position.
 - The thickness of the mattress chosen shall be such that the integral height (surface of the mattress to the upper edge of the cot frame) is at least 500mm in the lowest position of the bed base and at least 200mm in the highest position of the bed base.
 - For reasons of safety, we recommend the use of the Mamas & Papas cot bed mattress (1390mm x 690mm) for this cot.
 - The length and width shall be such that the gap between the mattress and the sides and ends does not exceed 30mm.
 - To prevent injury from falls, once the child is able to climb out of the cot, it should no longer be used for that child.
 - This child's bed conforms to BS8509:2008 + A1:2011.
 - When converted to a bed, this product is suitable from 18 months to 4 years
 - The mattress should be no more than 30mm shorter or narrower than the internal length or width of the cot/bed.
 - The child's bed, with the exception of the mattress base, can be dismantled for storage or transportation.
 - All assembly fittings should be tightened before use also checked periodically and re-tightened if necessary.
 - This child's bed may be cleaned with a damp cloth. Never use bleach or harsh abrasives.
 - Children are likely to play, bounce, jump and climb on beds, therefore the child's bed should not be placed too close to other furniture or windows, blind cords, curtain pulls or other strings or cords, and should be placed either tight to any wall or have a gap of 300mm between the wall and the side of the bed.
 - Do not use any additional or replacement parts other than those provided by Mamas & Papas.

ES



ADVERTENCIA:

- No utilice la cuna/cama infantil si alguna de las piezas está rota o estropeada, o si falta alguna pieza y use sólo piezas de repuesto aprobadas por Mamas & Papas.
 - Debe ser consciente del riesgo de chimeneas y otras fuentes de calor fuerte como fuegos eléctricos, fuegos de gas, etc, cerca de la cuna.
 - No deje nada en la cuna ni deje la cuna cerca de otro producto que pudiera servir como punto de apoyo o suponer un peligro de asfixia o estrangulamiento como por ejemplo cordeles o cordones de cortinas/persianas, etc.
 - No use más de un colchón en la cuna.
-
- Asegúrese de que todos los herrajes estén bien apretados antes del uso. Se deberían revisar y apretar los herrajes con regularidad cuando sea necesario.
 - Puede limpiar la cuna/cama con un trapo húmedo. No utilice nunca lejía ni productos abrasivos fuertes.
 - La posición más baja de la base es la más segura. Una vez su hijo sea lo suficientemente mayor para sentarse sin ayuda, la base debería usarse exclusivamente en la posición más baja.
 - La cama cuna, a excepción de la base del colchón, se puede desmontar para su almacenamiento o transporte.
 - El grosor del colchón elegido deberá ser tal que la altura interna (desde la superficie del colchón hasta el borde superior del marco de la cuna) sea de al menos 500 mm en la posición más baja de la base y al menos 200 mm en la posición más alta de la base.
 - Por motivos de seguridad, recomendamos el uso del colchón de cuna-cama (1390mm x 690mm) de Mamas & Papas para esta cuna.
 - El colchón no debería ser más de 30 mm más corto o más estrecho que el largo o el ancho interior de la cuna.
 - Para evitar lesiones por caídas, una vez que el niño pueda salir sólo de la cuna, ésta no debería ser utilizada más para ese niño.

FR



AVERTISSEMENT! / MISE EN GARDE!

- N'utilisez pas le petit lit si une partie, quelle qu'elle soit, est cassée, déchirée ou manquante, et utilisez exclusivement des pièces de rechange agréées par Mamas & Papas.
- Soyez vigilant aux risques que présentent des feux de cheminée et d'autres sources de chaleur intense (feux à barres électriques, feux au gaz, etc...) à proximité du petit lit.
- Ne laissez rien dans le petit lit et ne posez pas le petit lit à côté d'un autre objet qui pourrait servir de marchepied ou présenter un risque d'étouffement ou de strangulation, par ex. : cordes, cordons pour store/rideaux, etc...
- N'utilisez pas plus d'un matelas dans le petit lit.

- Vérifiez que toutes les fixations sont bien serrées avant de l'utiliser. Les fixations doivent être vérifiées et serrées régulièrement s'il y a lieu.
- Entretien : Le petit lit/lit enfant peut être nettoyé au chiffon humide. N'utilisez jamais d'eau de Javel ni d'abrasifs puissants.
- La position la plus basse du sommier est celle la plus sûre. Dès lors que votre enfant est suffisamment grand pour s'asseoir tout seul, utilisez le sommier exclusivement dans sa position la plus basse.
- Le lit d'enfant, à l'exception du socle pour le matelas, peut être démantelé pour le rangement ou le transport.
- L'épaisseur du matelas choisi doit être telle que la hauteur interne (écart entre la surface du matelas et le bord supérieur du cadre du petit lit) doit être d'un minimum de 50 cm sur la position la plus basse du sommier et de 20 cm dans la position la plus haute du sommier.
- Pour des raisons de sécurité, nous recommandons d'utiliser le matelas pour berceau Mamas & Papas (1390mm x 690mm) pour ce lit.
- Le matelas ne doit pas être plus court ni plus étroit de 3 cm par rapport à la largeur ou la longueur internes du berceau.
- Pour empêcher les blessures causées par des chutes, une fois que l'enfant est suffisamment grand pour sortir de son lit tout seul, ce lit ne lui convient plus.

D



WARNUNG:

- Die Wiege bzw. das Kinderbett darf nicht verwendet werden, wenn ein Teil defekt oder deformiert ist oder vollständig fehlt. Verwenden Sie nur die von Mamas & Papas empfohlenen Ersatzteile.
- Denken Sie an das Risiko durch offenes Feuer und andere starke Wärmequellen, wie zum Beispiel elektrische Feuer, Gasbrenner etc. in der unmittelbaren Nähe des Kinderbetts.
- Lassen Sie keine Gegenstände im Kinderbett liegen und stellen Sie es nicht in die Nähe eines anderen Produkts, auf den das Kind seinen Fuß stellen könnte, oder das eine Erstickungs- oder Strangulationsgefahr – z. B. Seile, Rollladen- oder Vorhangbänder etc. – darstellen könnte.
- Verwenden Sie in dem Kinderbett nicht mehr als eine Matratze

- Bitte stellen Sie vor der erstmaligen Verwendung sicher, dass alle Befestigungen korrekt angezogen sind. Die Beschläge sollten regelmäßig überprüft und im Bedarfsfall angezogen werden.
- Ihr Bett kann mit einem feuchten Tuch gereinigt werden. Niemals Bleichmittel oder aggressive Scheuermittel verwenden.
- In der niedrigsten Grundplatten-Position ist die Sicherheit am größten. Sobald Ihr Kind ohne Hilfe aufrecht sitzen kann, sollte die Grundplatte nur in der niedrigsten Position verwendet werden.
- Zum Transportieren oder Verstauen kann das Kinderbett (mit Ausnahme der Matratzen-Auflagefläche) auseinandergenommen werden.
- Die Dicke der ausgewählten Matratze sollte sich so darstellen, dass die interne Höhe (Oberkante der Matratze bis zur Oberkante des Kinderbettrahmens) in der niedrigsten Position der Bett-Grundplatte mindestens 500mm und mindestens 200mm in der höchsten Position der Bett-Grundplatte beträgt.
- Aus Sicherheitsgründen empfehlen wir, für dieses Bett nur Matratzen für Gitterbetten (1390mm x 690mm) von Mamas & Papas zu verwenden.
- Die Matratze darf nicht mehr als 30 mm kürzer oder schmaler als die interne Länge bzw. Breite des Bettchens sein.
- Sobald das Kind in der Lage ist, aus dem Kinderbett zu klettern, sollte das Bett aus Sicherheitsgründen nicht mehr für dieses Kind verwendet werden.

IT



AVVERTENZA:

- Non utilizzare il lettino/letto in presenza di componenti danneggiati, lacerati o mancanti e utilizzare solo ricambi approvati da Mamas & Papas.
- Fare attenzione alla presenza di fuochi o altre fonti di calore elevato, come fornelli elettrici, a gas, ecc. nelle vicinanze del lettino.
- Non lasciare nessun oggetto nel lettino né posizionare il lettino accanto ad altri oggetti che potrebbero servire al vostro bambino da punto di appoggio per sollevarsi o rappresentare pericolo di soffocamento o strangolamento come lacci, cordoni di avvolgibili/tende, ecc.
- Sistemare nel lettino un solo materasso.
- Verificare che tutti gli elementi di fissaggio siano serrati correttamente prima dell'utilizzo. Verificare e serrare gli elementi di fissaggio ove necessario.
- Pulire il lettino/letto con un panno umido. Non applicare mai sbiancanti o detergenti abrasivi.
- La posizione più bassa del lettino è quella più sicura. Quando il vostro bambino è abbastanza grande da poter stare seduto senza bisogno di aiuto, la base deve essere utilizzata esclusivamente nella posizione più bassa.
- Il letto del bambino, a eccezione della base del materasso, può essere smontato e riposto oppure trasportato.
- Lo spessore del materasso scelto dovrà essere tale da avere un'altezza interna (dalla superficie del materasso al bordo superiore del telaio del lettino) di almeno 500 mm nella posizione più bassa della base del letto e almeno 200 mm nella posizione più alta.
- Per motivi di sicurezza, si raccomanda di utilizzare su questo lettino esclusivamente materassi per lettino Mamas & Papas (1390mm x 690mm).
- Il materassino non deve essere più corto o stretto di 30 mm rispetto alla lunghezza o alla larghezza interna della culla.
- Per evitare lesioni in seguito a cadute, quando il bambino è in grado di arrampicarsi e uscire dal lettino, interromperne l'utilizzo.

NL



WAARSCHUWING:

- Het babybedje/kinderbed niet gebruiken als een onderdeel is gebroken, gescheurd of ontbreekt. Gebruik alleen reserveonderdelen die door Mamas & Papas zijn goedgekeurd.
- Wees bewust van de risico's van open vuur en andere sterke hittebronnen, zoals elektrische straalkachels, gaskachels enzovoorts in de buurt van het babybedje.
- Laat niets in het babybedje achter en plaats het bedje niet naast een ander product dat kan dienen als een plaats om op te staan of waardoor er gevaar bestaat voor verstikking of wurging, bijv. een snoer, een rolgordijn-/gordijnkoord enz.
- Leg niet meer dan één matras in het babybedje.
- Zorg voor gebruik ervoor dat alle onderdelen stevig en goed bevestigd zijn. De onderdelen moeten regelmatig gecontroleerd worden en waar nodig nog eens stevig worden vastgemaakt.
- Het babybedje/kinderbed kan met een vochtige doek worden afgenomen. Gebruik geen bleekmiddelen of agressieve schuurmiddelen.
- De laagste stand van de bedbodem is het veiligst. Wanneer uw kind oud genoeg is om zelfstandig rechtop te zitten, gebruik dan uitsluitend de bedbodem in de laagste stand.
- Het kinderbedje, met uitzondering van de matrasbodem, kan voor opslag of transport worden gedemonteerd.
- De hoogte van de gekozen matras moet zodanig zijn dat de interne hoogte (bovenkant van de matras tot de bovenste rand van het frame van het babybedje) minstens 500 mm is als de bedbodem in de laagste stand staat en minstens 200 mm als de bedbodem in de hoogste stand staat.
- Om veiligheidsredenen raden we aan de kindermatras (maat 1390mm x 690mm) van Mamas & Papas te gebruiken in dit ledikantje.
- De matras mag niet meer dan 30 mm korter en smaller zijn dan de lengte en breedte van de binnenkant van de wieg.
- Om verwondingen door vallen te voorkomen, moet het babybedje zodra het kind eruit kan klimmen, voor hetzelfde kind niet langer worden gebruikt.





mamas & papas®

HD5 0RH, UK



mamasandpapas.com
mamasandpapas.ca
mamaspapas.kr

UK T: +44 (0)345 268 2000

USA T: 1-800-490-0331

CAN T: 1-800-667-4111



/mamasandpapasuk
/mamasandpapasusa
/mamasandpapasmltaregion
/mamasandpapasmagyarorszag



@mamasandpapas



/user/mamasandpapasglobal



mamasandpapasblog.com



/mamasandpapas



/mamasandpapasuk
/mamasandpapasus



/+mamasandpapas

[SC14]
Bunny & Clyde Cot Bed
Lot:
00417
Made in Poland
Mamas & Papas
HD5 0RH, UK
F_0239_0112_V3