

# In-Tank Pump DW65v (9-654, 9-655\*)



The DW65v was designed specifically as a drop-in pump for VW/Audi applications such as 1.8t, 2.0 TSI, and 2.0 TFSI applications. 2 part numbers are available to fit FWD (9-654) and AWD (9-655). The DW65v flows 265lph at 40psi which is 40% more than the OE TT225 pump. In addition, the DW65v features a quiet and reliable turbine impeller which is compatible with pulse width modulated pump drivers. The pump also features an encapsulated armature for compatibility with ethanol based fuels. All DW fuel pumps are backed by a 3-yr no fault warranty.

To ensure maximum voltage at the pump, a 12-gauge hardwire kit is strongly recommended for optimum performance (DeatschWerks part #FPHWK)

## Specifications

<b>Weight</b>	22.4oz (635grams)
<b>External Materials</b>	Electroplated steel
<b>Inlet Fitting</b>	32.0mm ID, 35.4mm OD
<b>Outlet Fitting</b>	5/16" Hose Clamp
<b>PRV Activation</b>	>100psi
<b>Impeller Design</b>	Single Scroll Composite Turbine
<b>Connector Terminal</b>	Spade Pos/Neg
<b>Min Voltage Input</b>	6 Volts
<b>Max Voltage Input</b>	18 Volts
<b>Current Draw 40psi</b>	10.5 Amps (13.5v)

\*PN# 9-654 shown in picture, 9-655 features 2nd outlet.

## Dimensions

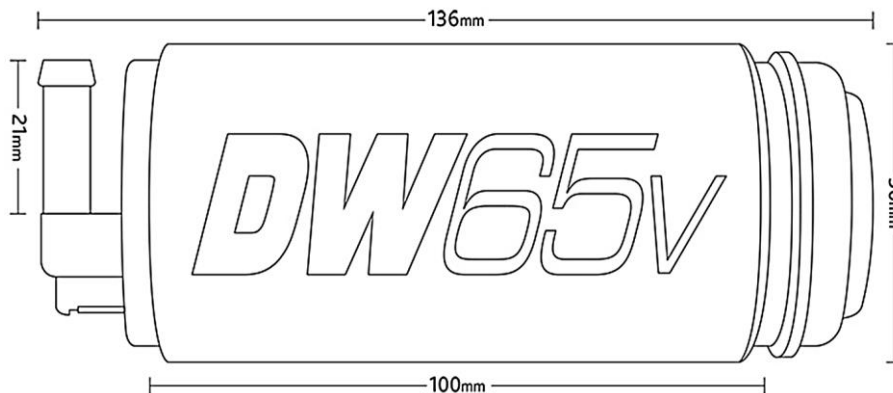

## Delivery Characteristics

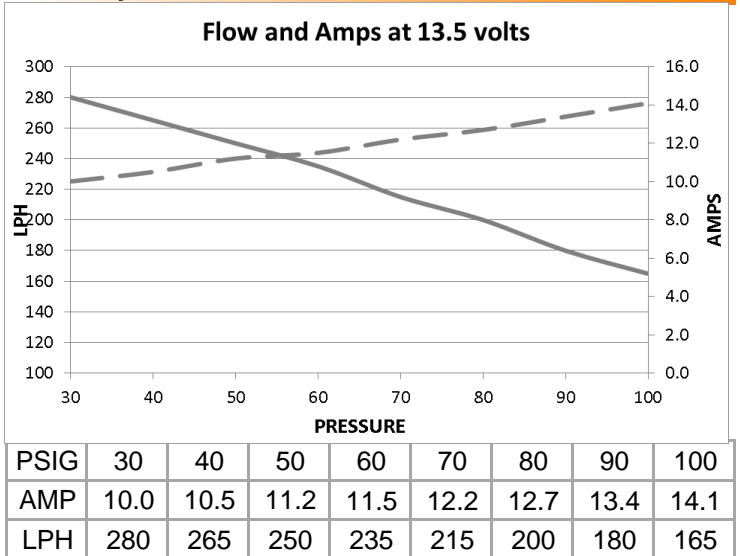

THIS PRODUCT MAY BE USED SOLELY ON VEHICLES USED IN SANCTIONED COMPETITION WHICH MAY NEVER BE USED UPON A PUBLIC ROAD OR HIGHWAY, UNLESS PERMITTED BY SPECIFIC REGULATORY EXEMPTION