

5.5 Liter Staged Surge Tank (6-000-55ST)



DW's staged surge tank is engineered to provide massive amounts of fuel flow reliably and consistently for racing applications. The DW 5.5 Liter Staged Surge Tank System includes the functionality of traditional surge tanks, with increased flexibility. This has been achieved by moving the pumps inside with a merged single point outlet that allows the use of single, dual, or triple pump configurations to meet fueling needs from 500hp to 2000hp

- Configurable for single, dual, or triple pumps
- Compatible with 39mm and 46mm pumps
- Single or Dual Stage Capability
- -10 AN O-Ring Boss Outlet
- High Amperage Threaded Stainless Steel Terminals

Specifications

Weight w/o Pumps	8.75 pounds (3.65 kilograms)
Material	Anodized Aluminum
Modular Design	One, Two or Three In-Tank Pumps
Pump OD Fitments	39mm or 46mm
Connector Terminal	M5 Stud x 4
Pump Outlet Fitting	-10 AN O-Ring Boss
Return/Inlet Fittings	-8 AN O-Ring Boss x 3
Max HP (DW400 x3)	2000+
Compatible Pumps	DW100, DW200, DW300 and DW400

Pump Mount Assembly



Dimensions

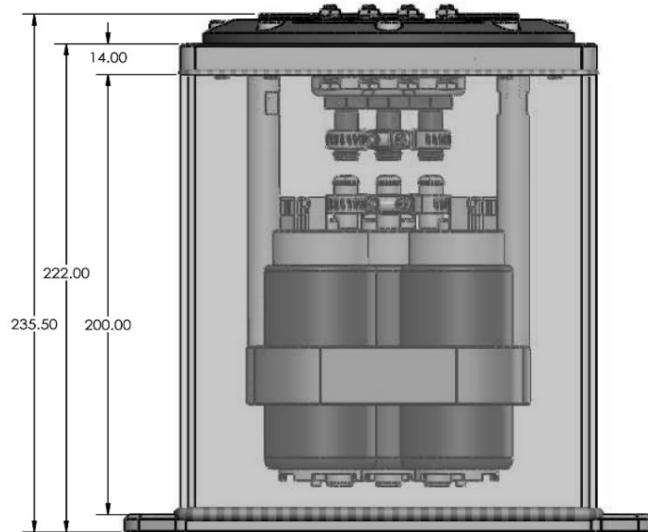
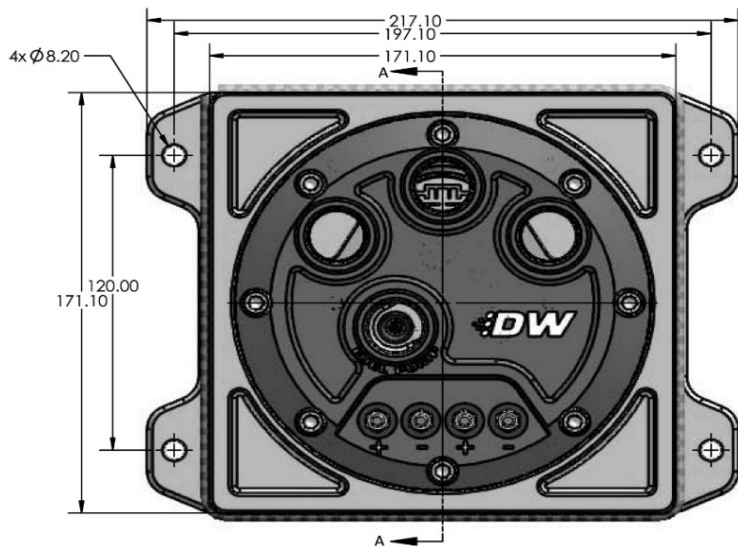

THIS PRODUCT MAY BE USED SOLELY ON VEHICLES USED IN SANCTIONED COMPETITION WHICH MAY NEVER BE USED UPON

A PUBLIC ROAD OR HIGHWAY, UNLESS PERMITTED BY SPECIFIC REGULATORY EXEMPTION

DeatschWerks, LLC 405-217-0701 techsupport@deatschwerks.com REV 10-07-19