

DESKY

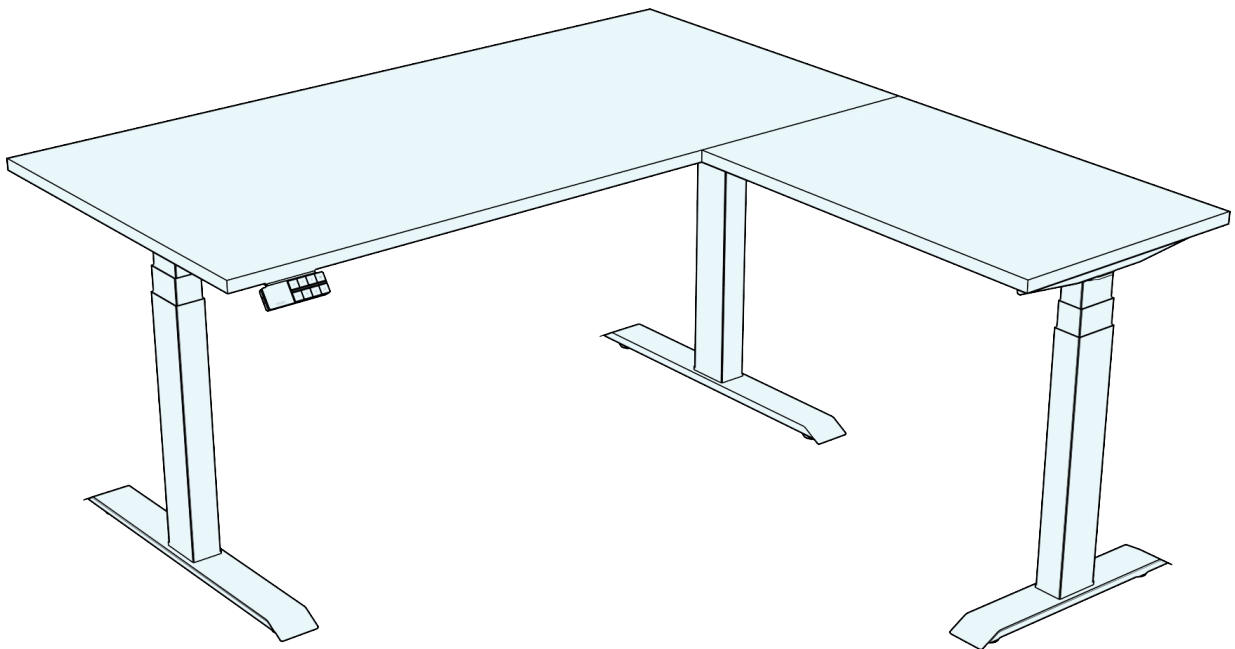

DESKY L-SHAPE SIT STAND DESK INSTRUCTION MANUAL

DESKY

Welcome!

Thank you for choosing DESKY. We are so excited that you will be creating a healthier work environment with one of our ergonomically designed electric height adjustable desks!

Whether your work happens at home or at the office you can benefit from the latest in height adjustable desk technology that comes in each DESKY height adjustable desk. Now you have the choice to sit or stand with a desk that adapts to your needs and style!

Please read this manual carefully and keep in a safe place for future reference.

We hope you enjoy your new DESKY!

-DESKY Team

INSTRUCTIONAL VIDEO



DESKY

Safety Instructions	4
Unpacking & Preparation	6
Parts List & Tools	7
Components Diagram	8
Assembly Instructions	9
Operating Controller	17
Programming Controller	18
Troubleshooting	22
Warranty Info	23

DESKY

SAFETY INSTRUCTIONS

Please read this Instruction Manual carefully. This desk is height adjustable so that it can be best positioned to suit a user's ergonomic height as directed in this manual.

Failure to comply with or observe all safety, assembly and operating instructions and warnings in this Instruction Manual may result in property damage, bodily injury or damage to the product itself.

Before beginning assembly of your DESKY:



Read and understand this Instruction Manual fully before attempting to assembly or operate the product. This is required to safely and properly operate the product.



Ensure that everyone who uses the product is familiar with the contents of this Instruction Manual.

Users must observe the following safety warnings:



Indoor use only. This product is designed for use in dry environments only and contains electric motors. Risk of fire, electric shock or injury if used outdoors.



Make sure there are no obstacles in the desk's height path. Do not place objects taller than 50cm under the desk frame. If objects taller than 50cm are required to sit underneath, please refer to the minimum and maximum height limit programming instructions in this manual.



Ensure all cords are an appropriate length to accommodate changes in the height of the desk during operation.



Do not sit or stand on the desk frame once assembled. Do not crawl or lie under the desk frame once assembled.



Only plug the desk into a properly grounded 240v (AU), 120v (US/CA) outlet. Unplug the desk from the electrical outlet before moving the desk or adding & removing accessories. Risk of electric shock.

DESKY

SAFETY INSTRUCTIONS



Do not open any desk component or insert any object in a desk component. Risk of electric shock. Opening any desk component will void the product warranty.



Keep fingers and all body parts clear of the moving desk and all moving components. Risk of crush injury and bodily injury.



The desk's anti-collision system is premised on proper operation by the user and observation of all directions in this manual. It is not a system that will avoid collisions under all conditions as different impacts may or may not cause the system's sensors to activate.



The desk's electric motors require a duty cycle of 10%. A 2 minute on, 18 minute off duty cycle is required based on a continuous motor run time. Not observing the correct duty cycle can over heat the motors and reduce their lifespan.



Do not expose desk components to liquids. In case of spilled liquids, immediately unplug the desk. Risk of desk failure or electric shock if desk components become wet.



In the event of a power outage/ surge or if the power cord is unplugged, a manual reset may be necessary - please see the troubleshooting section.

PRODUCT USE / LIABILITY

Prior to operating this desk for the first time, users must ensure that all components have been assembled as directed in this manual and that all cables are connected to the control box before it is connected to a power outlet.

Users must inspect all components and cables to ensure there are no signs of damage. Do not operate if there are signs of damage.

This desk is height adjustable so that it can be best positioned to suit a user's ergonomic height as directed in this manual. Any other use is at the user's risk. Under no circumstances does the manufacturer accept warranty claims or liability claims for damages caused from improper use or handling of the desk frame.

DESKY

UNPACKING AND PREPARATION

UNPACKING

It is important when you receive your DESKY that all frame components are carefully removed from the packaging and inspected for shipping damage.

Please report any damage to us immediately so we can rectify this for you as quickly as possible.



PREPARATION

Check the parts list in this manual to ensure that all necessary components have been received. The DESKY Corner Desk components are shipped in two (3) separate shipping boxes. Excluding the desktop.



If you have also ordered a desktop from us we recommend leaving this in its shipping box until it is needed to avoid any damage to the surface finish.

Remove all desk frame components from the packaging and lay on a non-abrasive surface like a carpet or rug. Contact with hard and/or abrasive surfaces may cause damage to the finish of the desk frame. Count all pieces before disposing of any packaging material.

Before assembly, consider where you want your desk to be located. You will need a clear, dry indoor area to set up and assemble your desk. All the necessary tools to set up your DESKY frame are included for easy assembly.



NOTE: If you have not purchased a desktop from us with threaded screw inserts or pre-drilled holes you will need a Phillips head screwdriver or power drill to fix the frame to your desktop.

DESKY

PARTS LIST & TOOLS

BOX 1

A - CROSSBAR ENDS
QTY: 2

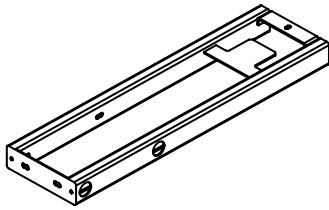

B - CROSSBAR RAILS
QTY: 2

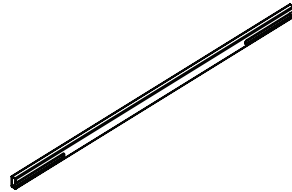

C - SIDE BRACKETS
QTY: 2

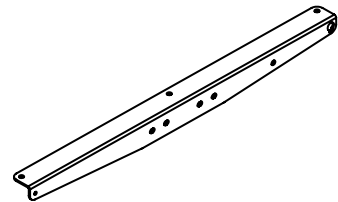

D - FOOT
QTY: 2

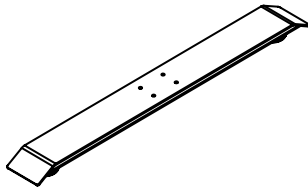

E - HEX KEY
QTY: 2 - Size 4

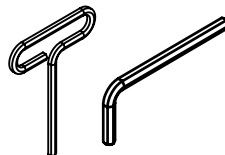

F - MACHINE SCREWS
QTY: 38 - M6x14mm



G - GRUB SCREWS
QTY: 8 - M6



H - TIMBER SCREWS
QTY: 14 - 10Gx15mm



I - CABLE CLIPS
QTY: 10

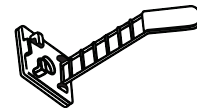

BOX 2

J - LEGS
QTY: 2

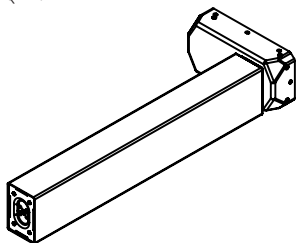

K - CONTROLLER
QTY: 1

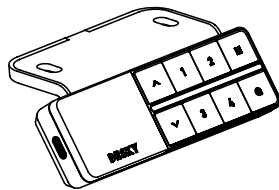

L - POWER CABLE
QTY: 1

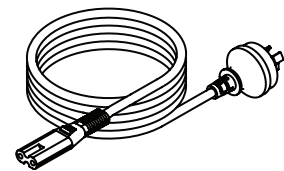

M - IC LEG CABLES
QTY: 2

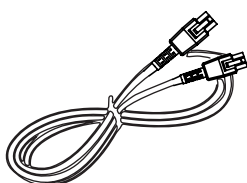

DESKY

PARTS LIST & TOOLS

BOX 3

N - CROSSBAR END

QTY: 1

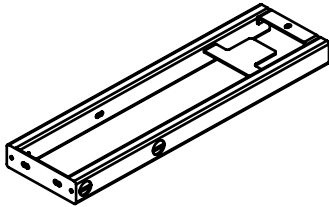

O - CROSSBAR RAILS

QTY: 2

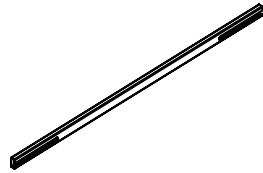

P - SIDE BRACKETS

QTY: 1

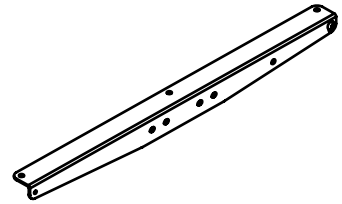

Q - FOOT

QTY: 1

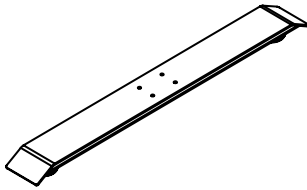

R - CONNECTING CROSS
BAR

QTY: 1

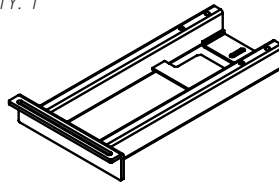

S - MACHINE SCREWS

QTY: 16 M6x14



T - TIMBER SCREWS

QTY: 5



U - HEX KEY

QTY: 1

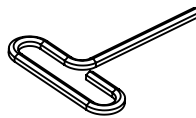

V - CONTROL BOX

QTY: 1

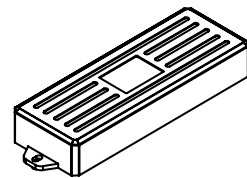

W - LEG

QTY: 1

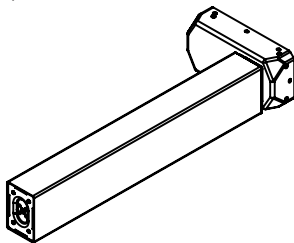

DESKY

COMPONENTS DIAGRAM

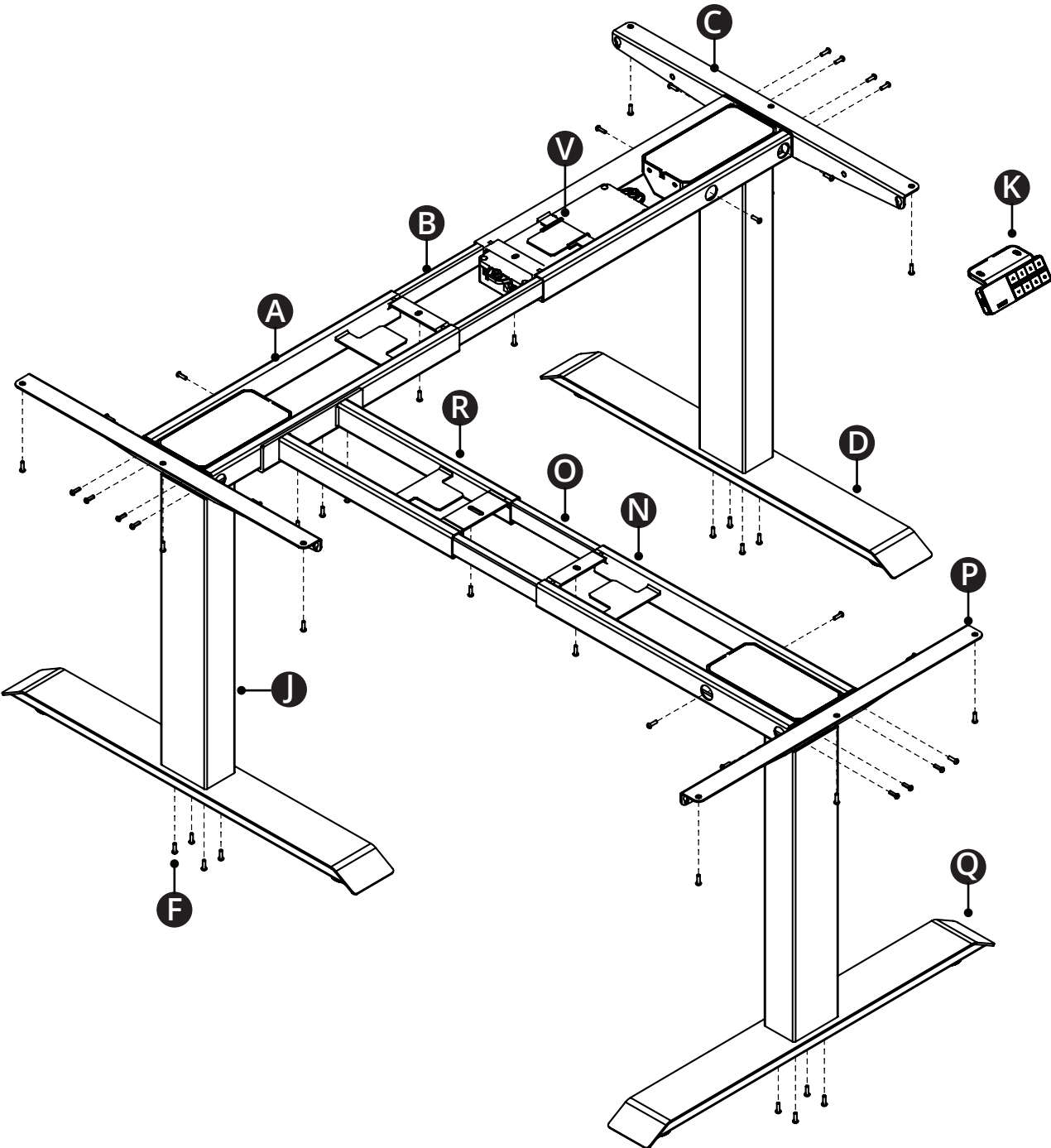

DESKY

ASSEMBLY INSTRUCTIONS

Step 1

Place the two Crossbar Ends (A) upside down so that the eight (8) machine grub screw holes (G) are facing upward as pictured.

The Crossbar Rails (B) are located inside the Crossbar Ends (A) and will need to be removed and set aside for later steps.

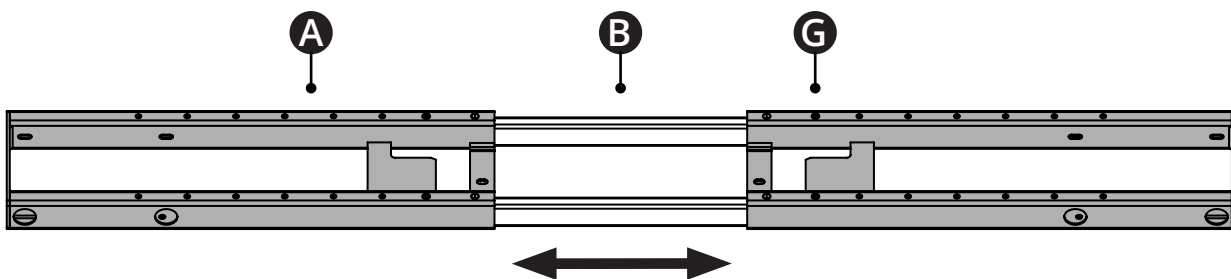

Step 2

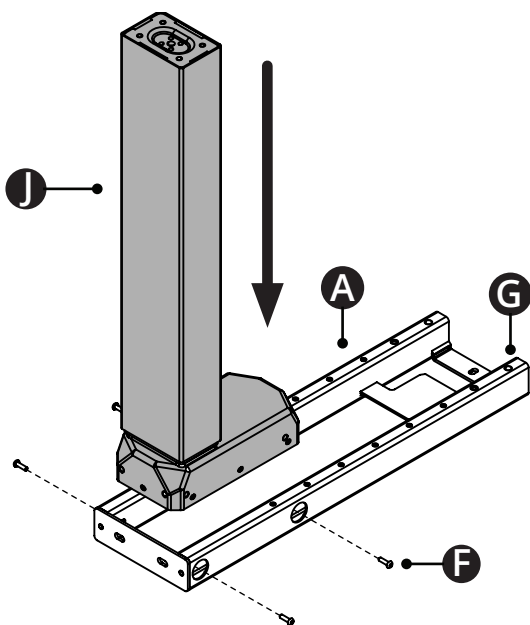

Place the Crossbar end (A) upside down as pictured and insert the leg (J) so that the four (4) holes in the leg line up with the 4 holes on the crossbar end.

Ensure that the Crossbar end is orientated so that the machine grub screws (G) face upward when inserting the leg.

Insert four (4) Machine screws (F) and use the Hex key (E) to scw in a few turns. **Do not tighten completely.**

Repeat this step for the second and third leg. Note that the third leg frame components (box 3) are smaller, keep these together.

DESKY

ASSEMBLY INSTRUCTIONS

Step 3

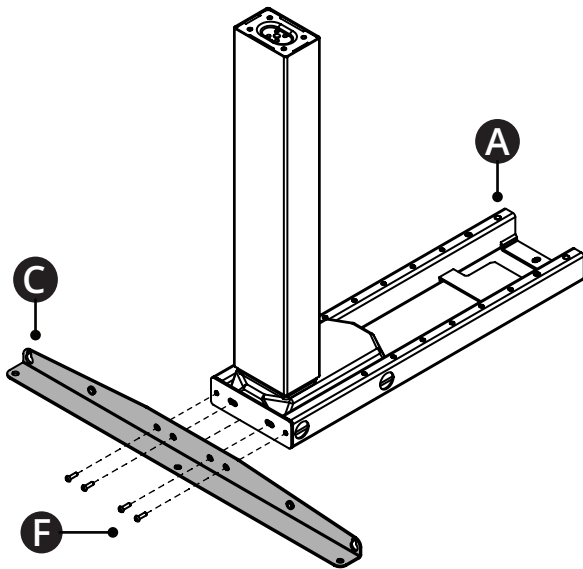

Position the Side bracket (C) against the back of the Crossbar end (A) so that the four (4) holes in the side bracket line up with the holes on the crossbar end.

Insert four (4) Machine screws (F) and use the large Hex key (E) to screw in a few turns. **Do not tighten completely.** Start with the two outside screws first.

Repeat this step for the second and third leg.

Now tighten all the Machine screws (F) from Steps 2 and 3.

Step 4

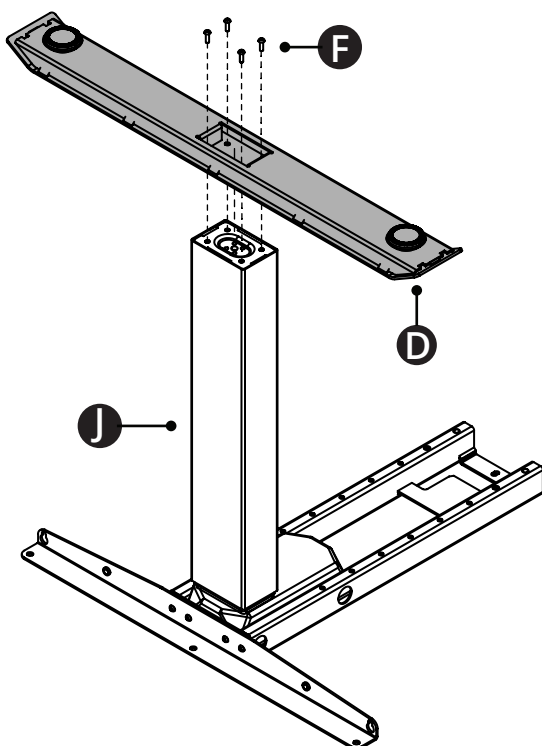

Place the Foot (D) onto the leg (J) as shown so that the four holes in each line up.

Insert four (4) Machine screws (F) and use the large Hex key (E) to screw in a few turns. Once all four screws have been started, tighten completely.

Repeat this step for the second and third foot.

Round levelling feet/ studs are attached to each foot to assist with levelling the desk.

DESKY

ASSEMBLY INSTRUCTIONS

Step 5

Slide the two Crossbar rails (B) into the two Crossbar ends (A) to connect the frame assembly.

Ensure the crossbar rails are orientated so the rail cut-outs face inward as shown.

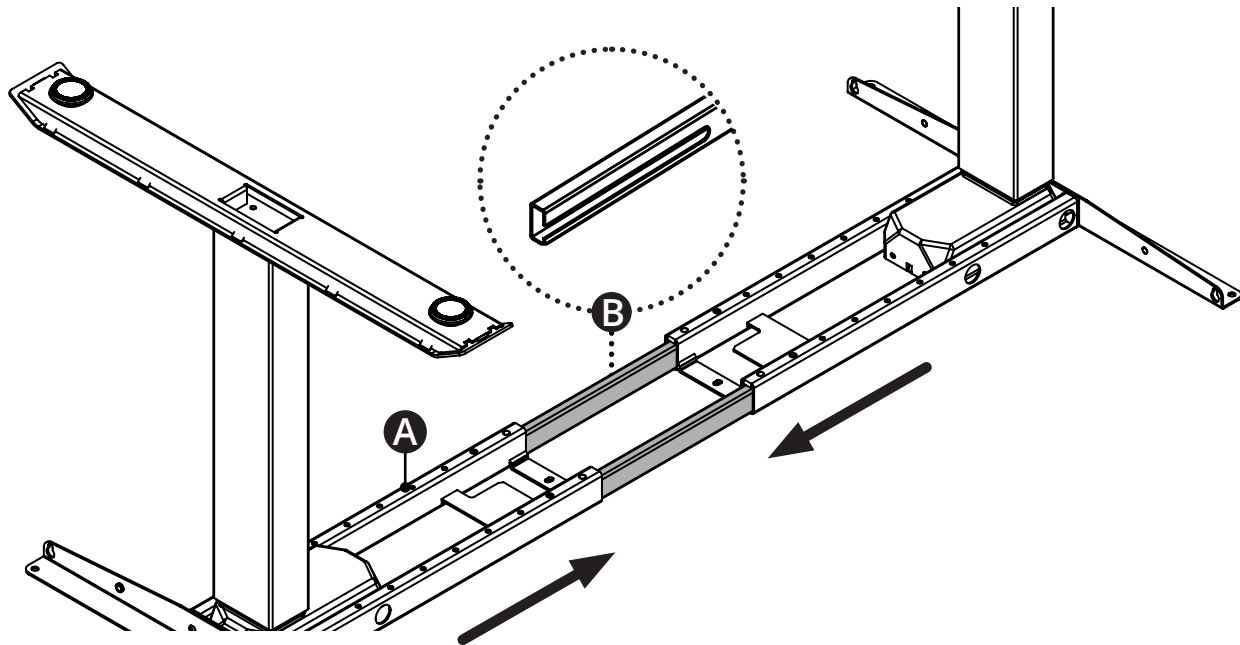

Step 6

Place your desktop upside down on a non-abrasive surface like a carpet or rug and place the frame on top. Adjust the width of the frame by pulling the two halves apart to line up with the pre-drilled holes or threaded screw inserts in the desktop.

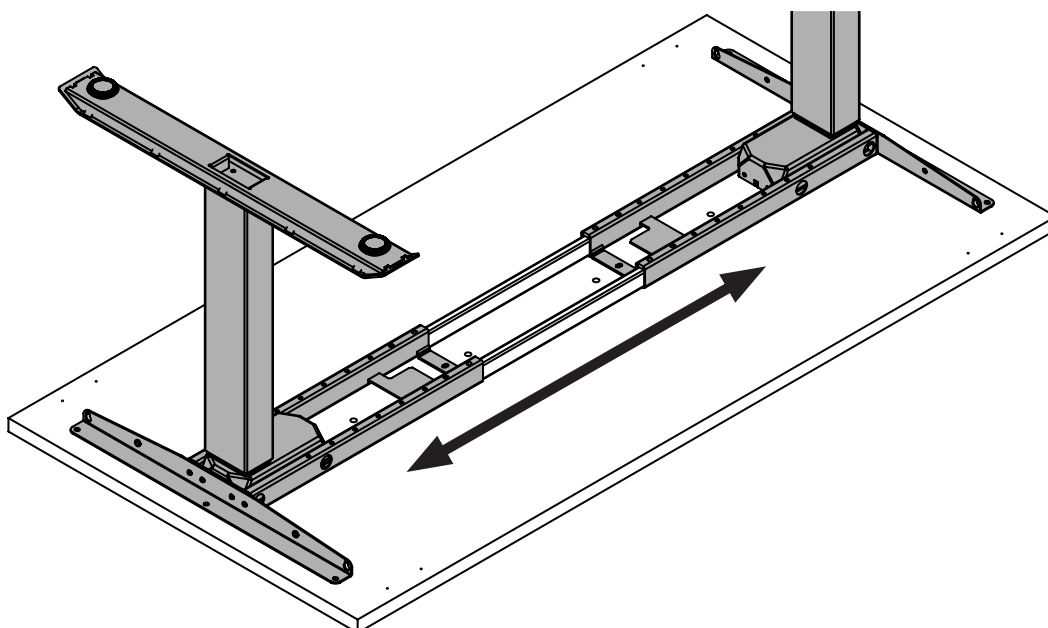

DESKY

ASSEMBLY INSTRUCTIONS

Step 7

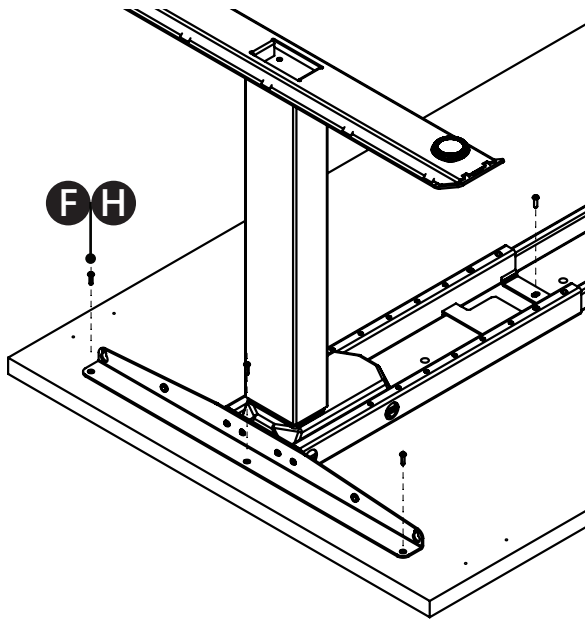

Your desktop will have pre-drilled holes or threaded screw inserts, depending on the desktop you have purchased from us.

Desktops with threaded screw inserts: use eight (8) Machine screws (F) to secure the frame to the desktop.

Desktops with pre-drilled holes: use eight (8) Timber screws (H) to secure the frame to the desktop.

Insert all screws and tighten loosely. Once all eight screws are in, tighten the frame to the desktop completely.

If your desktop does not have threaded screw inserts or pre-drilled holes you will need to pull the frame apart to position each leg assembly close to the edge of the desk. If you have also purchased the Integrated Cable & Power Channel you will need to make sure the frame is not too wide to attach the channel between the Side brackets (C).

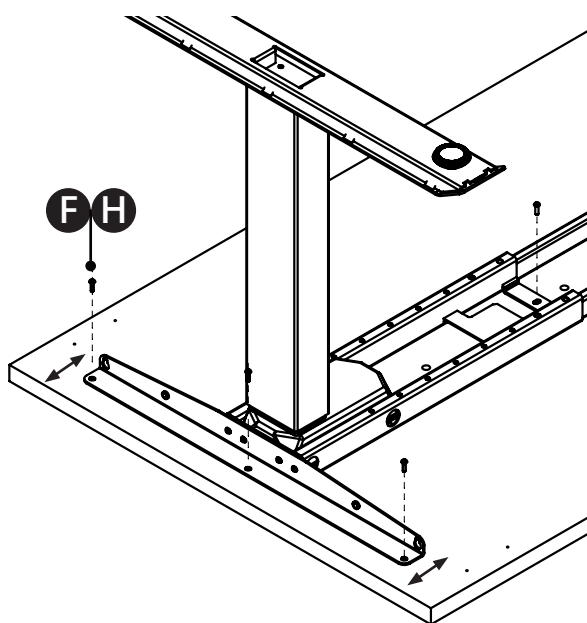

To position the frame in this instance we recommend using the guide below to measure the minimum distance between the edge of your desk and screw holes in the side brackets.

1200mm (48") length desktop - 25mm (1")
1500mm (60") length desktop - 50mm (2")
1800mm (72") length desktop - 80mm (3.1")

Use eight (8) Timber screws M5 (H) to secure the frame to the desktop.

DESKY

ASSEMBLY INSTRUCTIONS

Step 8

Use the Hex key (E) provided to insert and tighten each Grub screw (G) on the Crossbar ends (A) and secure the Crossbar rails (B) in place.

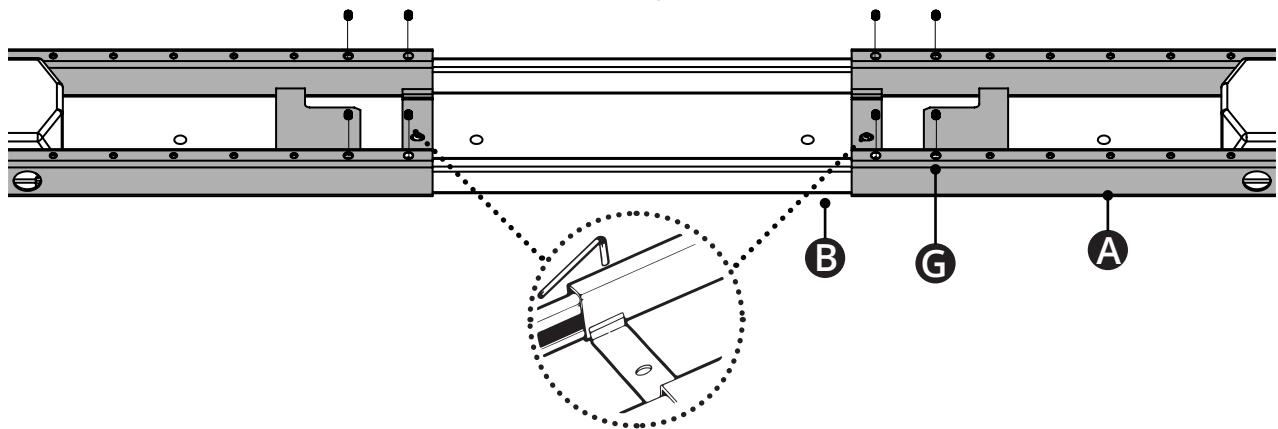

Step 9

Secure the Connecting Crossbar (R) to your assembled Cross Bar (A) using three machine screws (F). Note keep these machine screws semi loose as you will need to align the crossbar and desktop in the following steps.

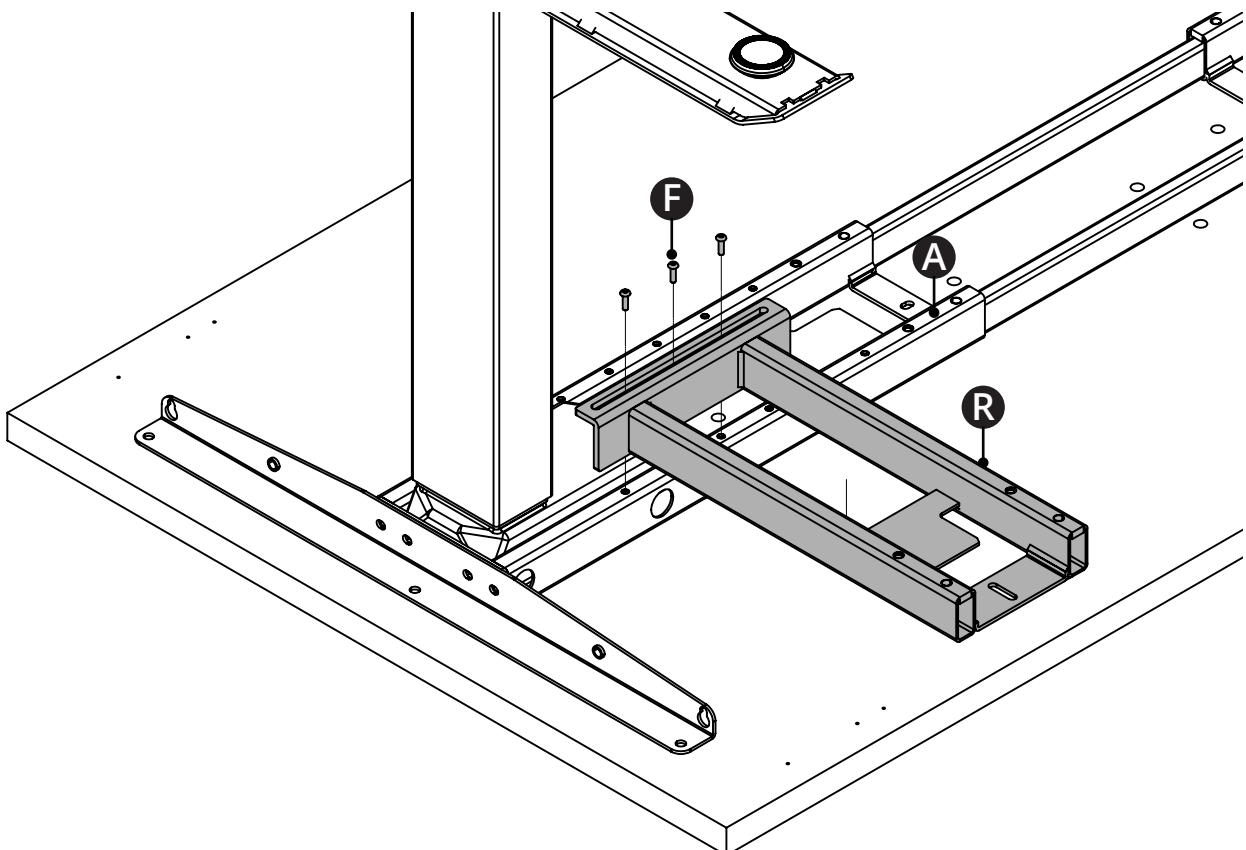

DESKY

ASSEMBLY INSTRUCTIONS

Step 10

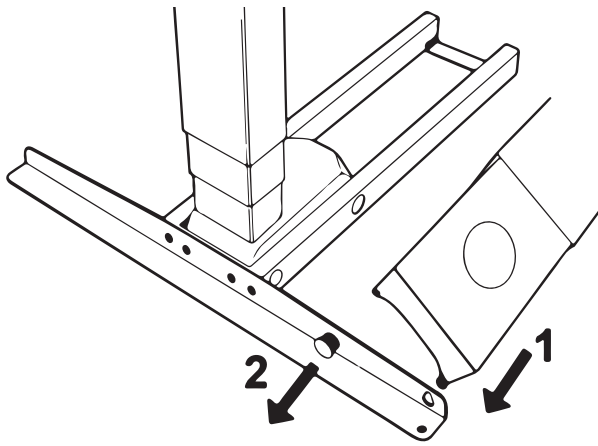

If you have purchased the Integrated Cable & Power Channel, secure one end to the Side bracket (C) as shown and extend the width of the channel to meet the other side bracket.

Make sure the spring release knob is screwed into the side bracket securely.

Attach the other end of the channel to the side bracket in the same manner.

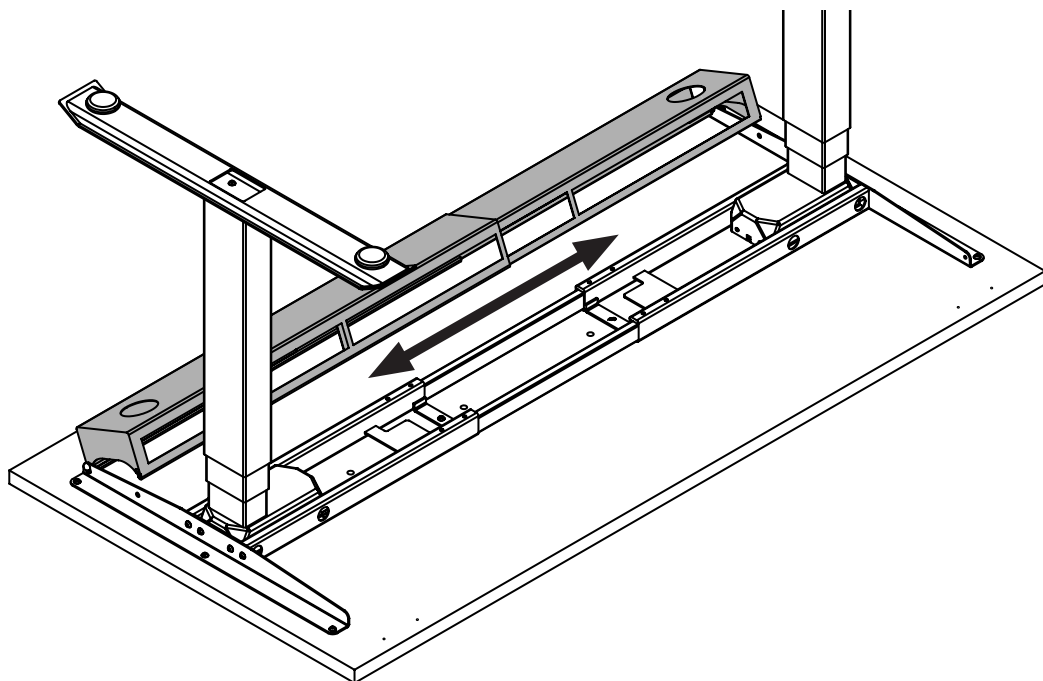

Step 11

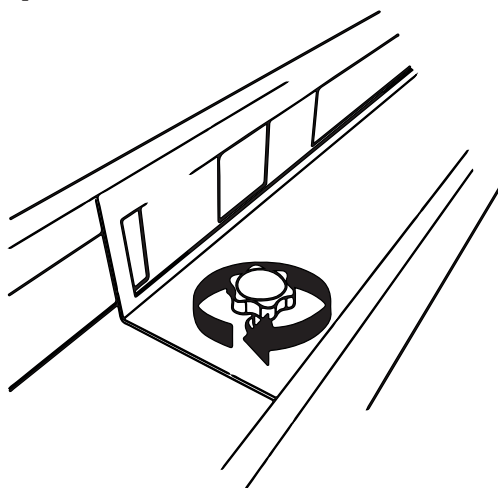

Tighten the screw in the centre of the channel to secure the two sides of the channel in place.

Cables and wiring can be placed in the channel.

DESKY

ASSEMBLY INSTRUCTIONS

Step 12

Line up the pre-drilled holes in the desktop with the holes on the controller (F) as shown and use two (2) Timber screws M5 (H) to secure the controller to the desktop. If your desk has threaded inserts use 2 machine screws (F).

The controller can be placed anywhere along the front edge of the desk but there are pre-drilled holes on the left and right sides of the desktop for ease depending on whether you prefer the controller to be accessible from the left or right.

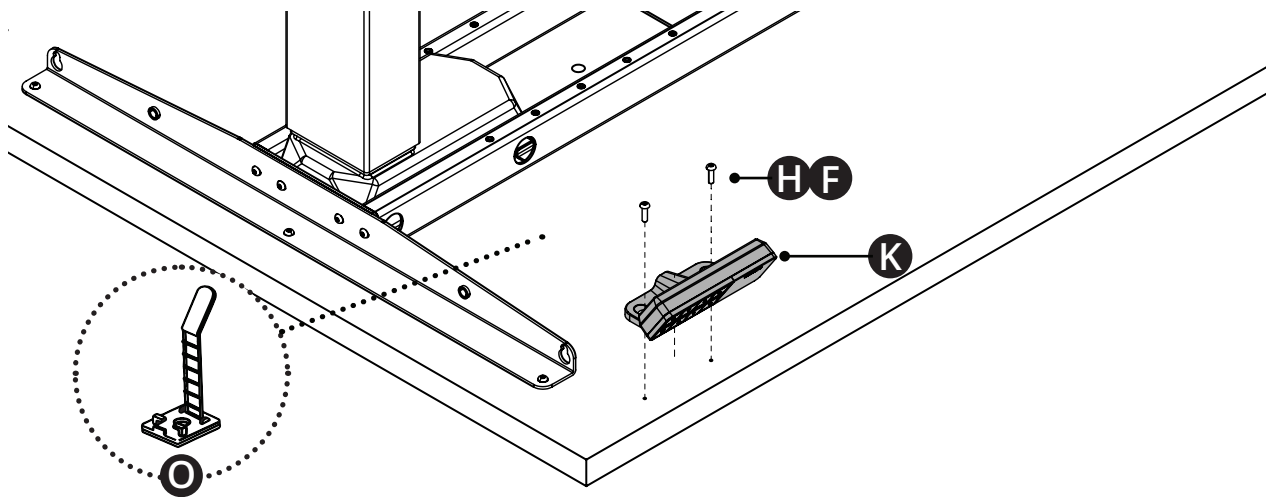

Step 13

Two person lift: with one person on each side of the main desk section, hold the desk top with one hand and the leg with the other. Carefully rotate the desk until the feet on the back side of the desk contact the floor. Ensure the desk is rotated backwards to avoid damage to the front mounted controller.

Rotate the desk again to sit upright on the floor. Use the leveling studs to level the desk. Make sure you position the main section of the corner desk in its allocated spot as moving the fully assembled desk can be difficult.

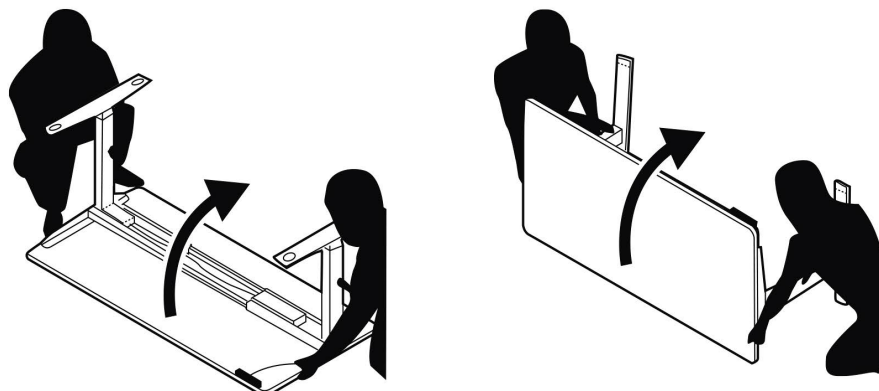

DESKY

ASSEMBLY INSTRUCTIONS

Step 14

After repeating steps 2-4 with the components found in the Third Leg Box (N,P,Q,W). Attach the third leg assembly onto the connecting cross bar (R) using the center rails (O).

Leave the third leg assembly section loose on the center rails, do not tighten any screws as you will need to align the desk top before securing the frame.

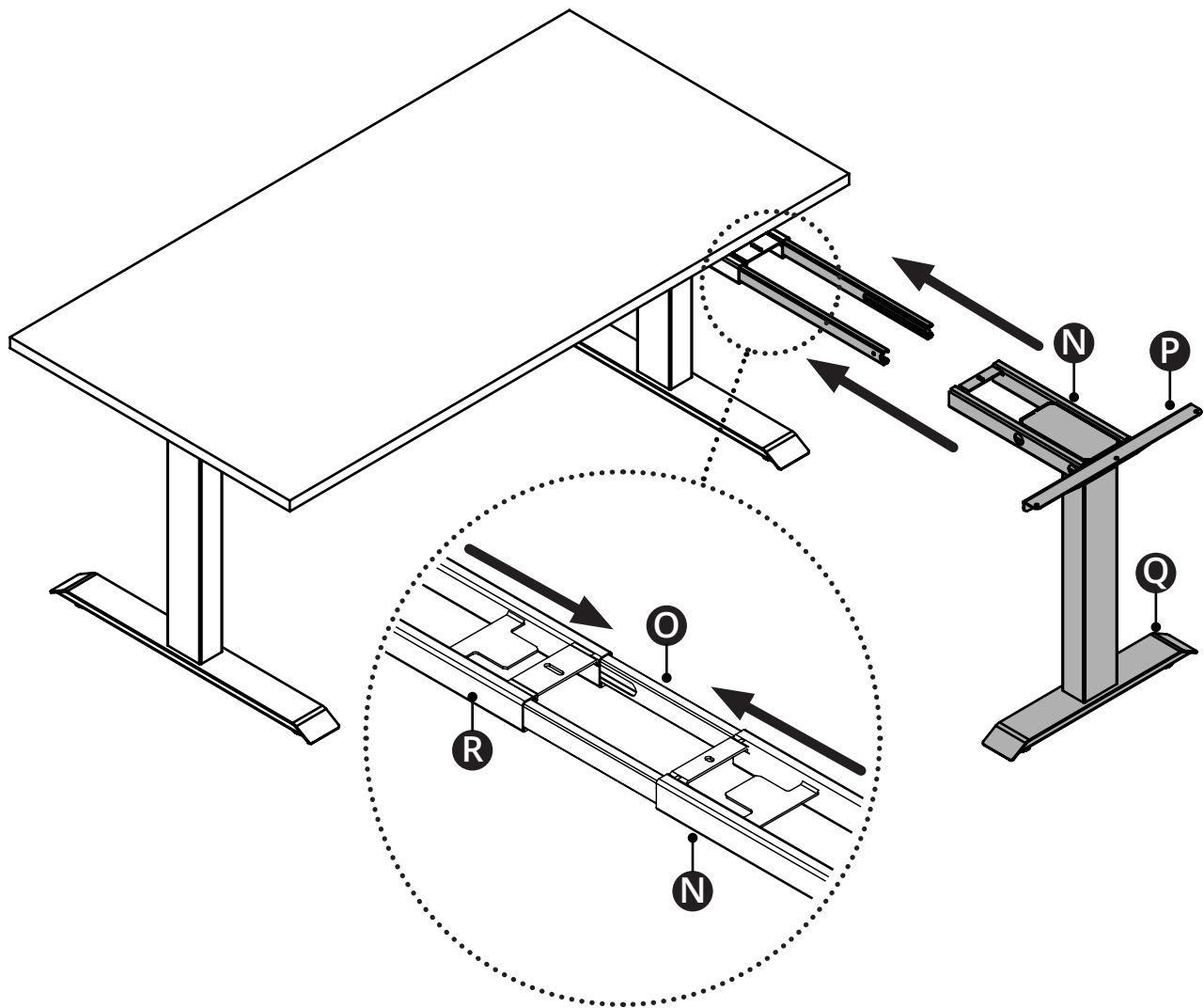

DESKY

ASSEMBLY INSTRUCTIONS

Step 15

Slide the smaller desktop section onto the frame. Align all of the pre-drilled threaded inserts with the holes on the frame.

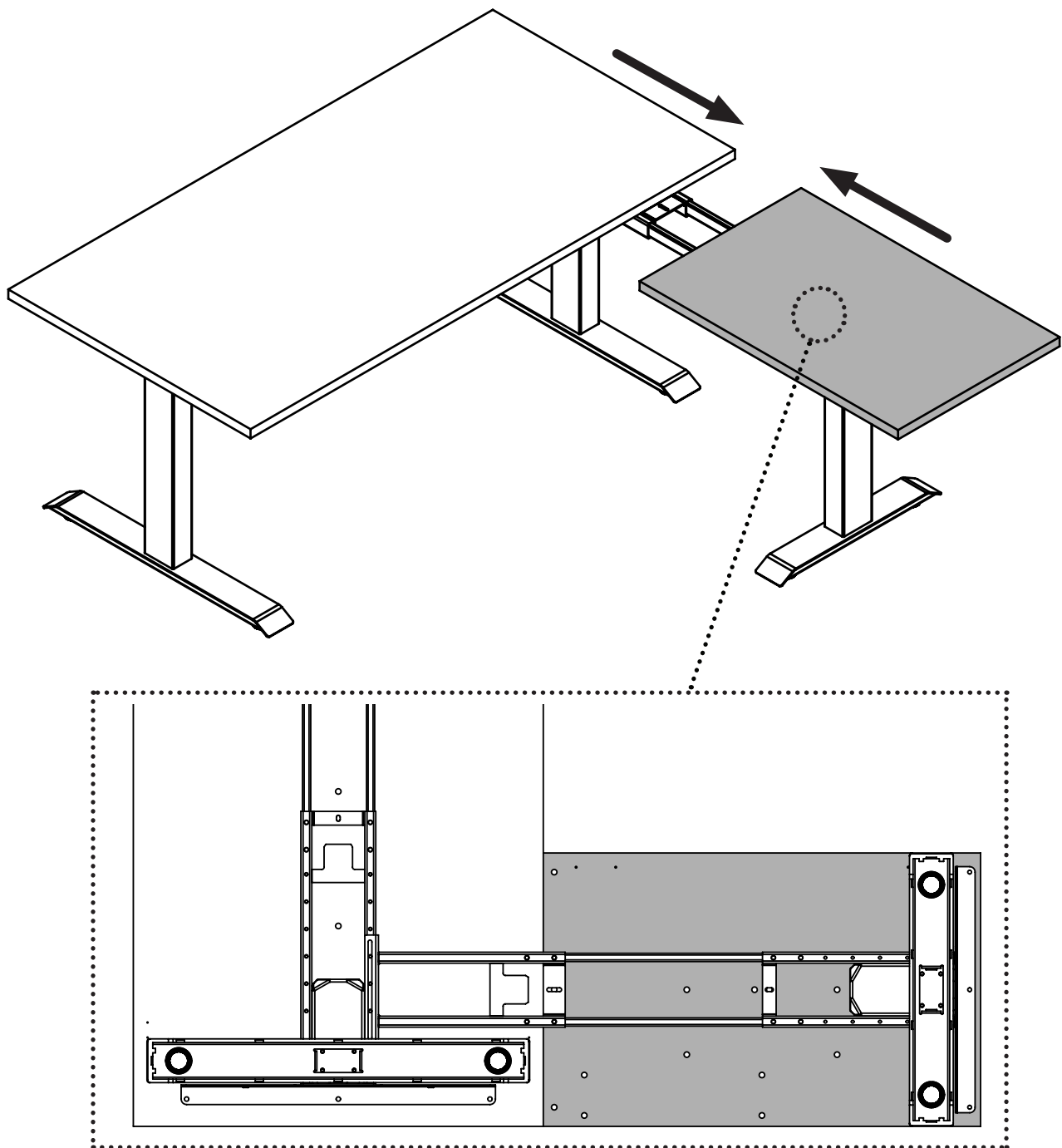

From the underside of the smaller desktop align all of the holes

DESKY

ASSEMBLY INSTRUCTIONS

Step 16

Once the third leg assembly is aligned to the holes on the desktop secure the frame using 5 Machine Screws (F/S). If you are using your own desktop you can secure the frame using the provided Timber Screws (H/T).

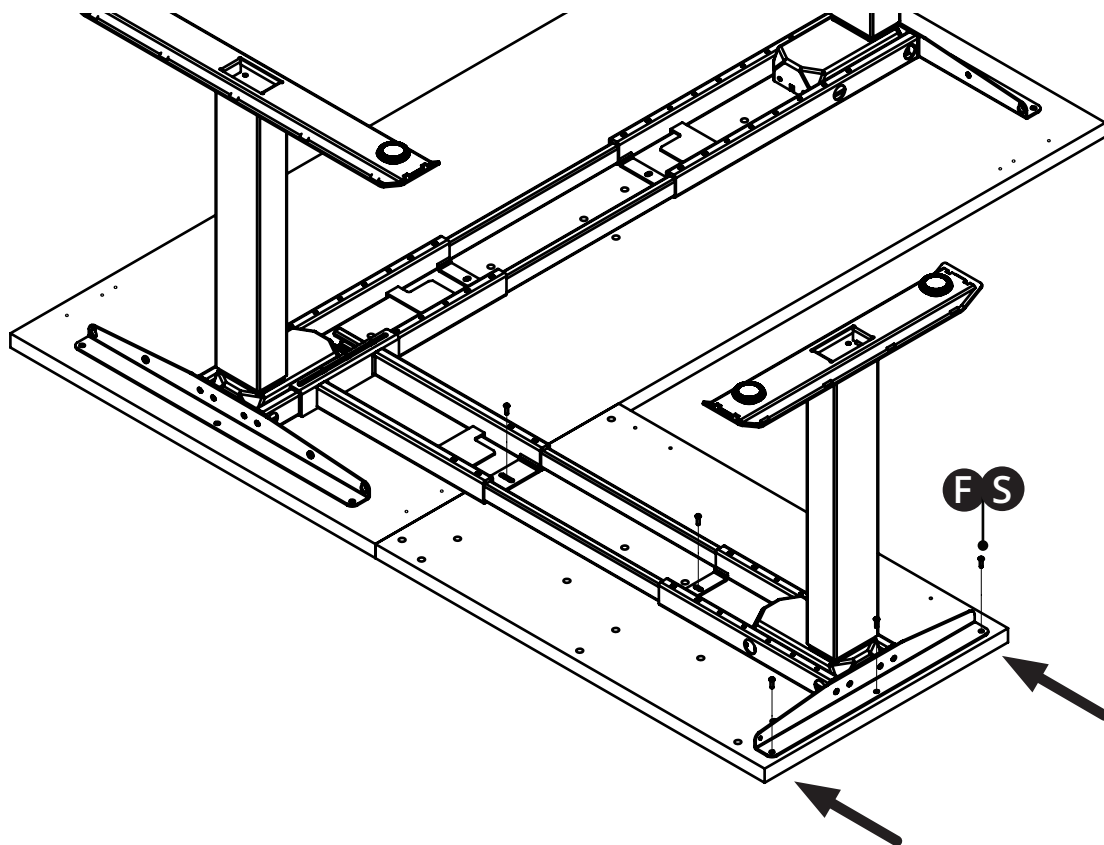

Step 17

Use the Hex key (E) provided to insert and tighten each Grub screw (G) on the Connecting Crossbar (R) and the Crossbar End (N) locking the Crossbar Rails (O) in place. Make sure to tighten the hex screws securing the Connecting Crossbar (R) to the Cross Bars (A).

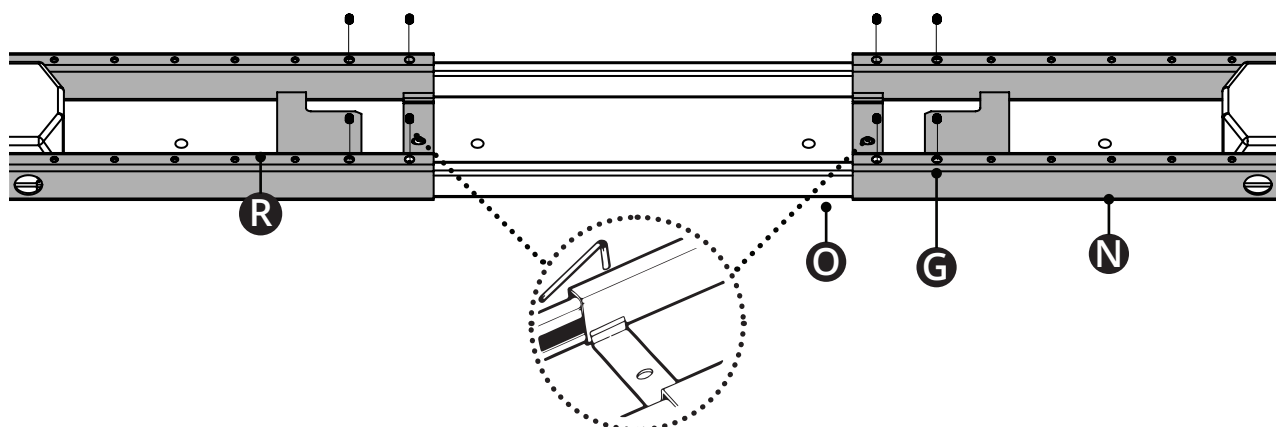

DESKY

ASSEMBLY INSTRUCTIONS

Step 18

Secure the Control box (K) to your desk by position the Control box in between the two Crossbar rails (A) so that the attachment guides on the underside of the Control Box line up with the bracket on the Crossbar end. Slide the Control box onto this bracket all the way until it is securely in place.

Alternatively use two (2) Timber screws (H) to secure the control box to the desktop.

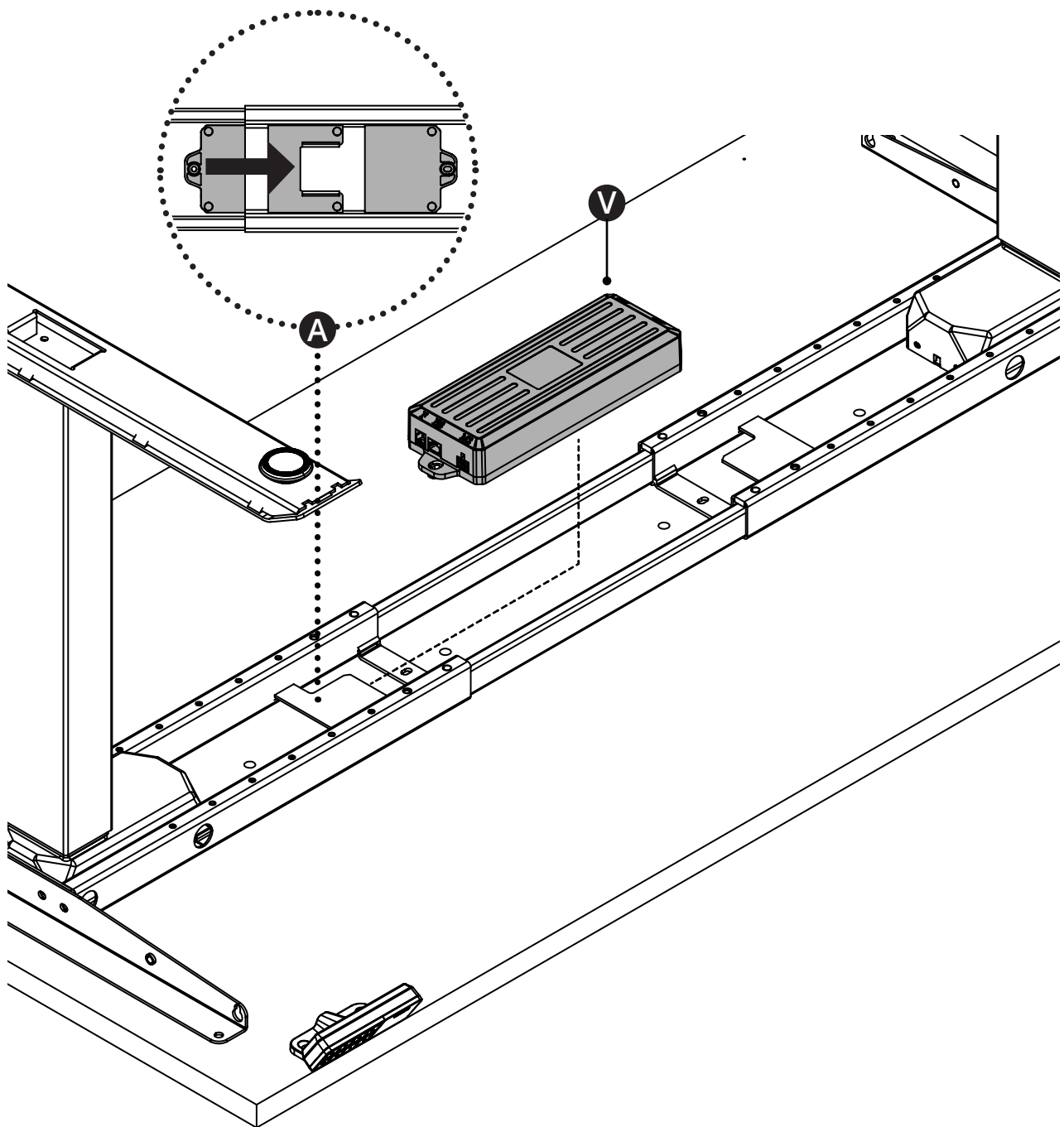

DESKY

ASSEMBLY INSTRUCTIONS

Step 19

Connect the Power cable (N) and the controller (L) to the control box (K) as shown. Use the interconnecting IC Leg cables (M) to connect each leg (J) to the control box. Note: smaller desktops will not need the IC Leg cables.

Use the adhesive backed cable clips (I) to tidy the cables and secure to the underside of the desktop so the cables do not hang.

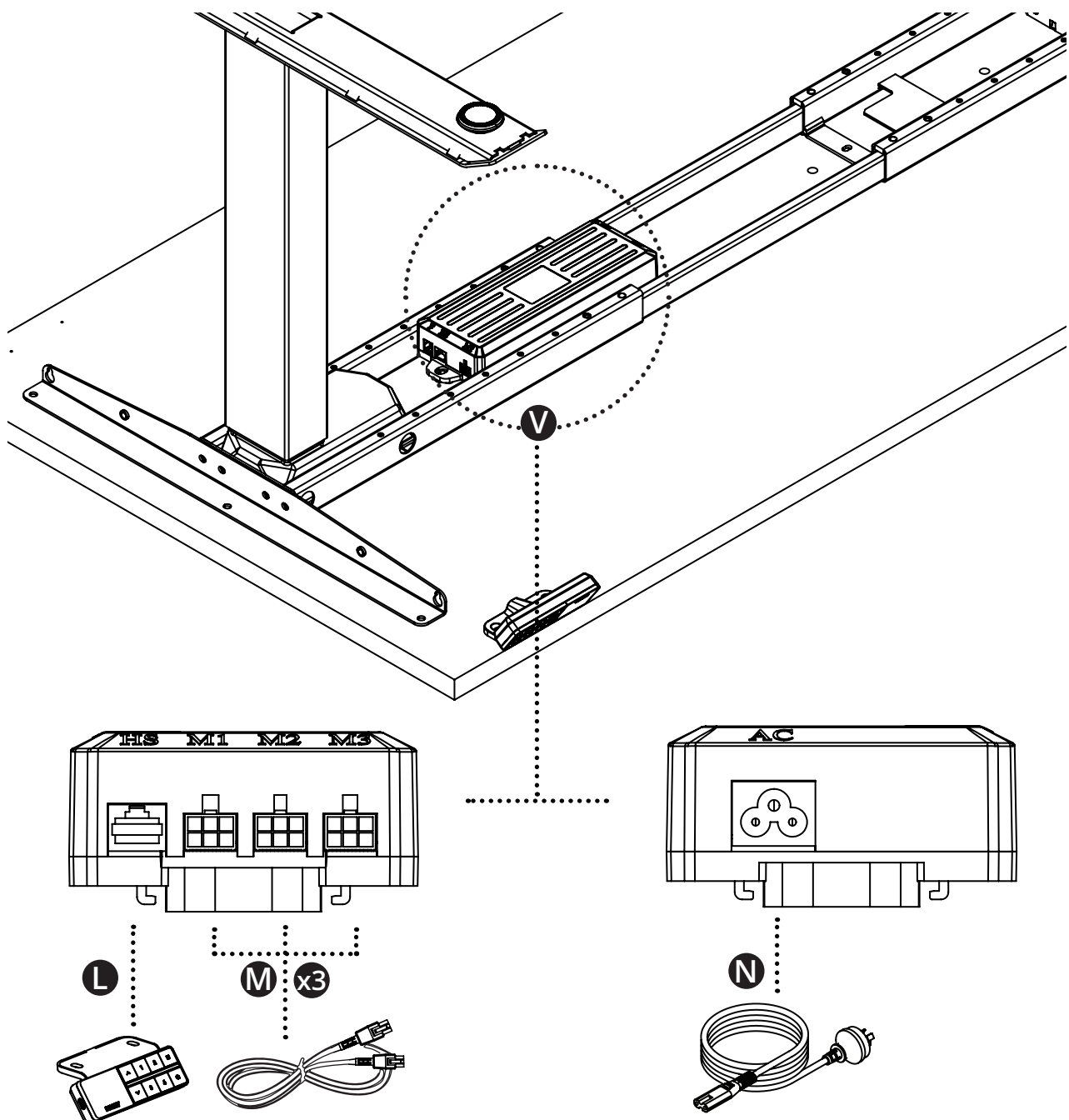

DESKY

OPERATING CONTROLLER



Please read the Safety Instructions at the start of this manual before proceeding.

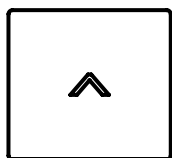
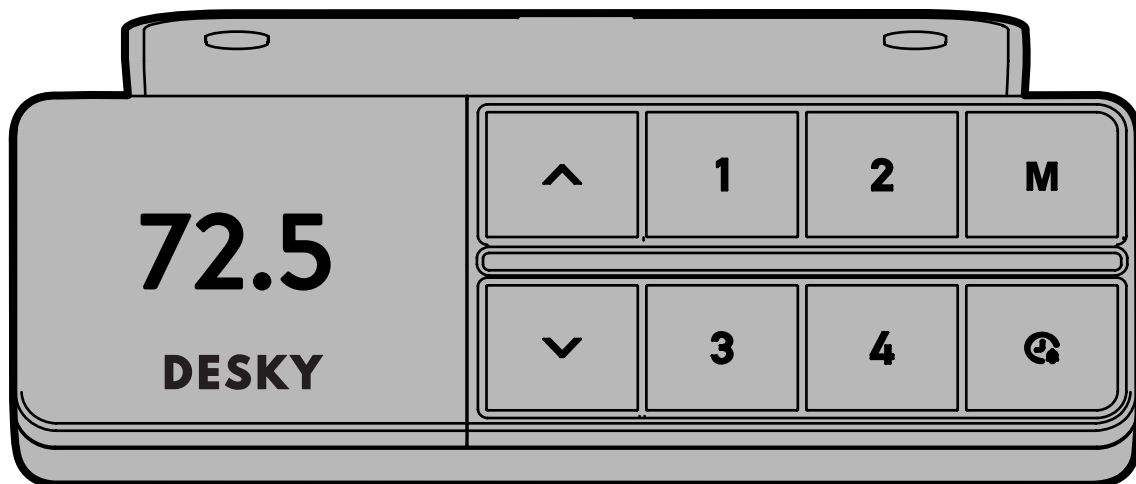

Height UP

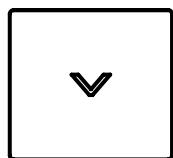

Height DOWN

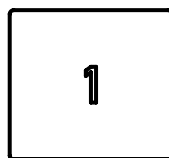

Memory Presets

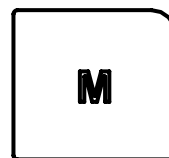

Store Memory

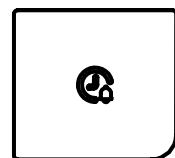

Standing Reminder

Desk Reset Procedure

You will need to RESET the desk prior to first use.

1. Press and hold the **DOWN** button until the desk reaches its lowest position, then release.
2. Press and hold the **DOWN** button again for 10 seconds until the display reads 'RESET'.
3. Press and hold the **DOWN** button again until the desk lowers a little bit more and then slightly rises. Release the **DOWN** button, the desk will display the height and is now ready for use.

Basic Operation - Up & Down

Press and hold either the **UP** or **DOWN** button to raise or lower the height of the desk. Release the button to stop at a particular height or until the desk reaches its upper or lower limit.

DESKY

PROGRAMMING CONTROLLER

Memory Presets

There are Memory Preset buttons to store four desk heights for quick access to specific height changes.

Steps:

1. Press and hold the **UP** or **DOWN** buttons to raise or lower the desk to your desired height.
2. Press the **M** button. The display will show a love heart
3. Press one of the Memory Preset buttons to save the current height of the desk to that number.
4. Press one of the Memory Preset buttons to return the desk to the stored height for that preset.

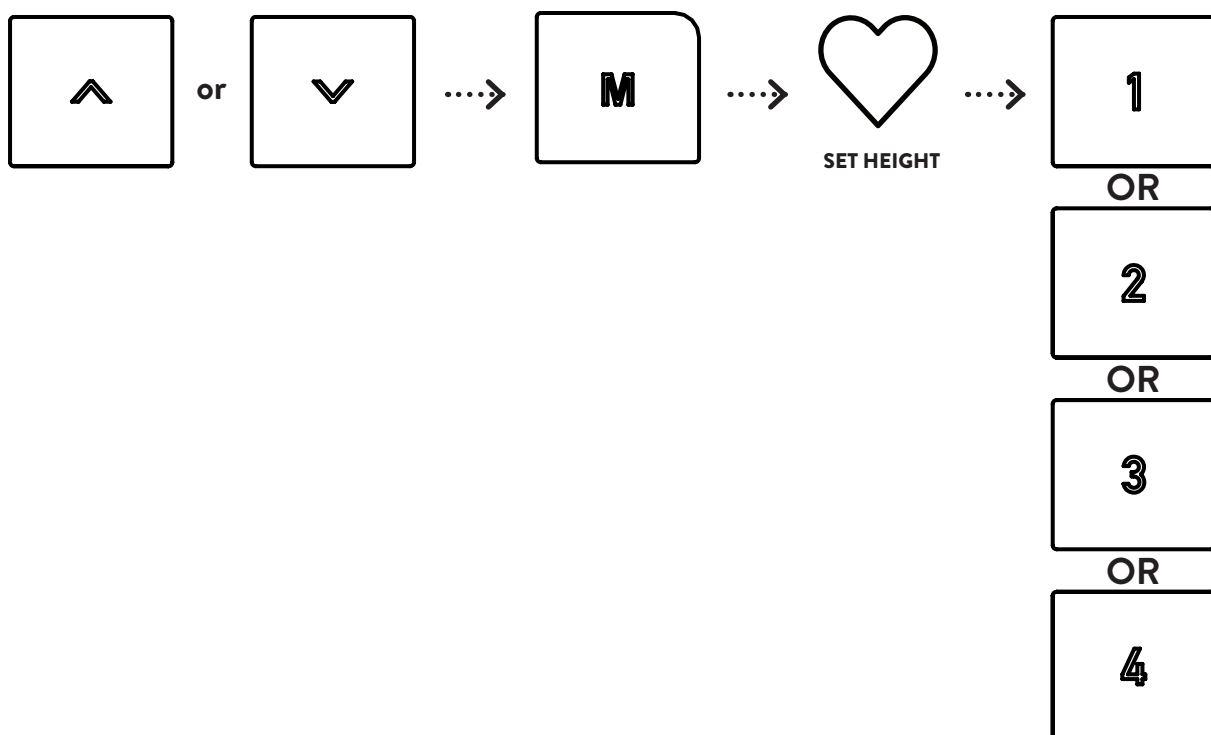

DESKY

PROGRAMMING CONTROLLER

Setting a Standing Reminder

You can easily and quickly set yourself a standing, sitting or general timer using the dedicated button on the hand controller

Steps:

1. Press the reminder button.
2. Press the up or down arrow to cycle through the timer you wish to select 30, 45, 60 or 120 minutes or off.
3. Press the reminder button again to activate the timer. The timer will then show a progress bar counting down on the display and on the LED RGB. Your controller will then vibrate when the timer is up reminding you to stand, sit or complete your current task and move on.

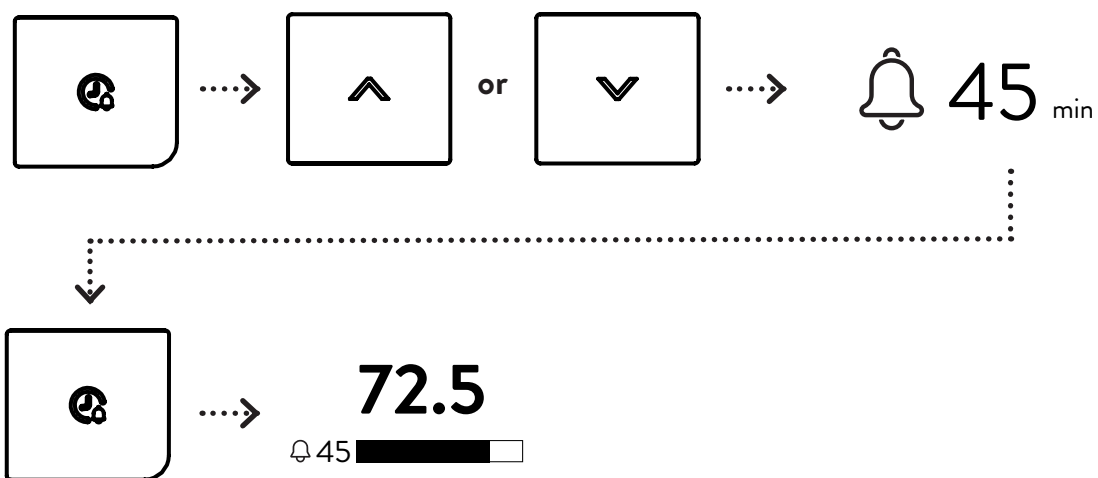

Maximum and Minimum Height Limits

The default height range of the desk is from 60cm up to 125cm to provide the widest possible height range that will best suit a user's ergonomic seated or standing position.

The controller can be programmed to set maximum and minimum height limits if you require. This may be necessary if you need to avoid hitting objects above or below the desk at specific heights.

Note: if previous preset heights fall outside new limits set these will need to be reprogrammed, otherwise the preset will just move to the maximum/ minimum set.

Steps:

1. Press and hold the **UP** or **DOWN** button to raise or lower the height of the desk to the required maximum or minimum height.
2. Hold the '**M**' button for around 4 seconds. The display will show the spinning settings cog.
3. Once the settings have been launched, navigate to the **SET MIN/MAX** Icon, press **M** to launch the setting.
4. Navigate to choose **SET MAX** or **SET MIN** and then press **M** to confirm your maximum or minimum height.
5. To remove any set height follow the above process and select the **OFF** option within the settings.

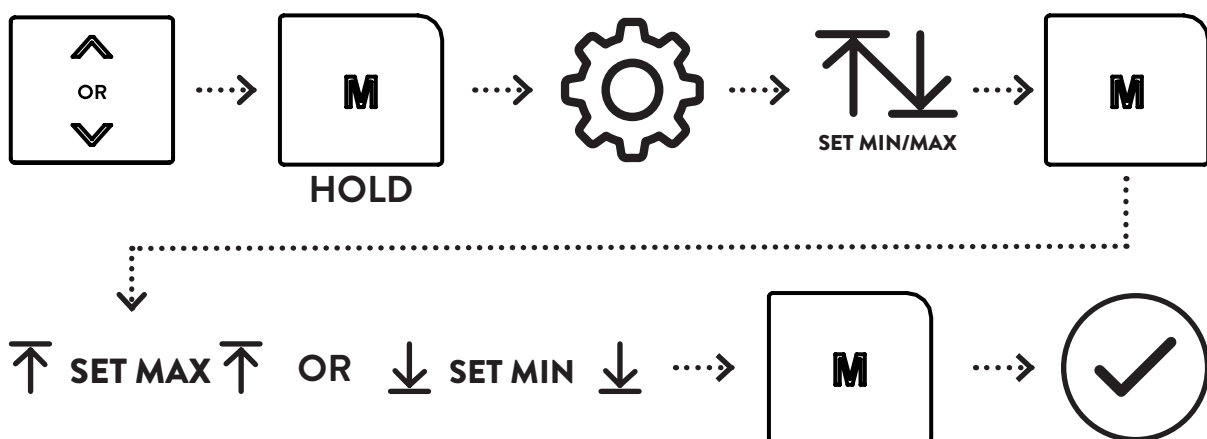

Controller Safety Lock

The controller can be locked to prevent any undesired or accidental activation of the controller and desk. This is recommended when children are present.

Steps:

1. Press any button to wake the controller. Hold the **M** button for 4 seconds. The display will show the spinning settings cog, wait until settings are launched.
2. Once the settings have been launched, navigate using the **UP** and **DOWN** arrow to the **LOCK** icon, press **M** to launch the setting.
3. Press **UP** or **DOWN** to choose between **LOCK** or **UNLOCK** or back to menu.
4. Press the **M** button to confirm the setting locking or unlocking your desk.

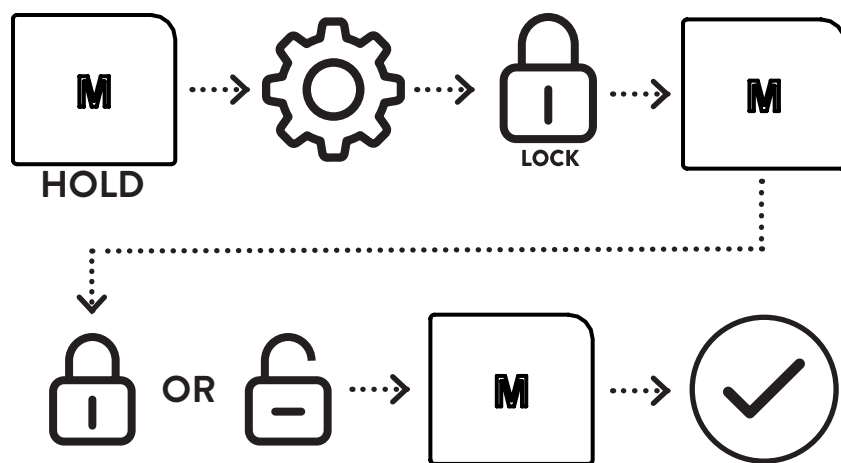

Note: when locking the controller it will lock after the screen auto turns off. You can briefly unlock the controller again by pressing and holding 'M' it will then stay unlocked until the screen auto turns off and lock's again. To remove the lock follow the process above.

DESKY

PROGRAMMING CONTROLLER

Display Height CM/Inches

The controller display height can be programmed to show height in centimeters or inches.

Steps:

1. Press any button to wake the controller. Hold the **M** button for 4 seconds. The display will show the spinning settings cog, wait until settings are launched.
2. Once the settings have been launched, navigate using the **UP** and **DOWN** arrow to the **UNIT** icon, press **M** to launch the setting.
3. Press **UP** or **DOWN** to choose between **CM** or **INCHES** or back to menu.
4. Press the **M** button to confirm the displayed unit of measurement for your desk.

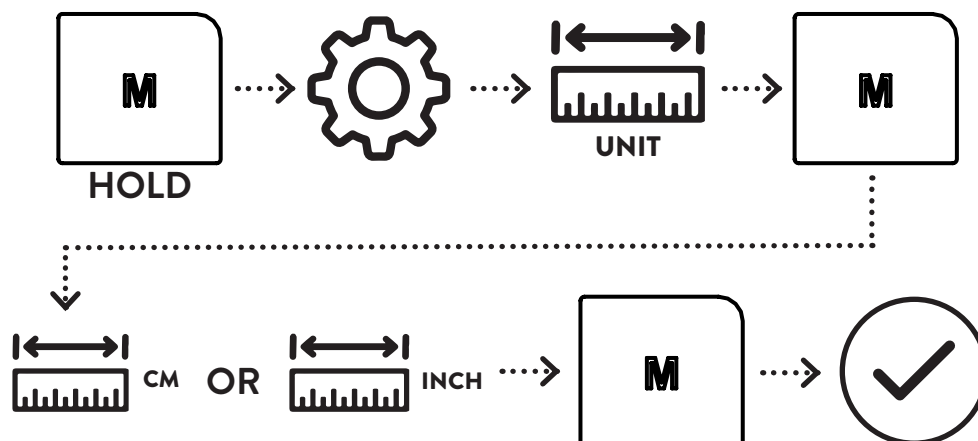

Calibrating Display Height

At its lowest position the desk sits at a height of 60cm from the ground to the top of the desk frame (underside of the desktop). You may wish to calibrate this height to the top of your desktop.

Steps:

1. Press any button to wake the controller. Hold the **M** button for 4 seconds. The display will show the spinning settings cog, wait until settings are launched.
2. Once the settings have been launched, navigate using the **UP** and **DOWN** arrow to the **DISPLAYED HEIGHT** icon, press **M** to launch the setting.
3. Your height numbers will start flashing, using the **UP** and **DOWN** arrows to set your displayed height to your true desk height.
4. Press the **M** button to confirm your displayed true height.

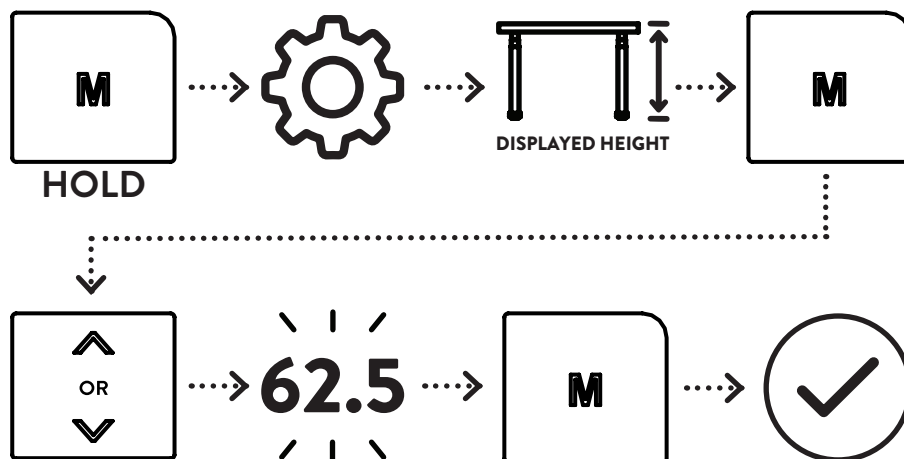

Changing Anti-Collision Impact Detection Sensitivity

You may wish to alter the anti-collision impact detection sensitivity if you find the anti-collision system is engaging accidentally or you want to increase the sensitivity which the system engages.

Steps:

1. Press any button to wake the controller. Hold the **M** button for 4 seconds. The display will show the spinning settings cog, wait until settings are launched.
2. Once the settings have been launched, navigate using the **UP** and **DOWN** arrow to the **IMPACT DETECTION** icon, press **M** to launch the setting.
3. Using the **UP** and **DOWN** arrows to set your collision sensitivity to:
HIGH = Most Sensitive (10kg pressure)
MEDIUM = Mid Sensitivity (15kg pressure)
LOW = Least Sensitive (20kg pressure)
4. Press the **M** button to confirm the sensitivity.

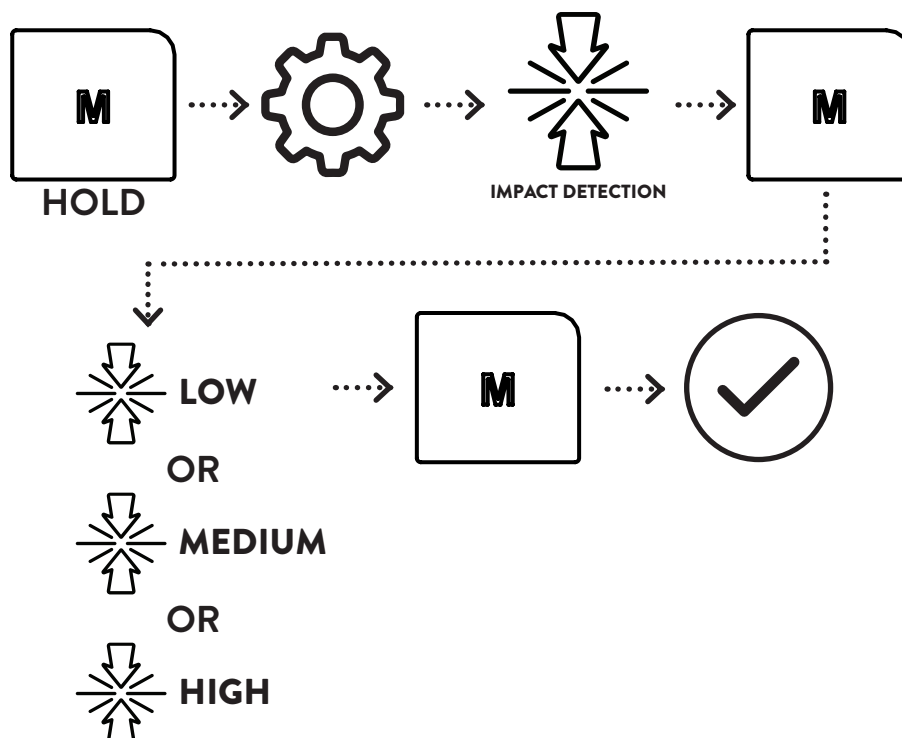

Changing Controller LED's

If you wish to change your controllers RGB LED's you can cycle through the various options by following the instructions below.

Steps:

1. Press any button to wake the controller. Hold the **M** button for 4 seconds. The display will show the spinning settings cog, wait until settings are launched.
2. Once the settings have been launched, navigate using the **UP** and **DOWN** arrow to the **RGB LIGHT** icon, press **M** to launch the setting.
3. Using the **UP** and **DOWN** arrows cycle through the different colour options.
4. Press the **M** button to confirm your chosen colour.

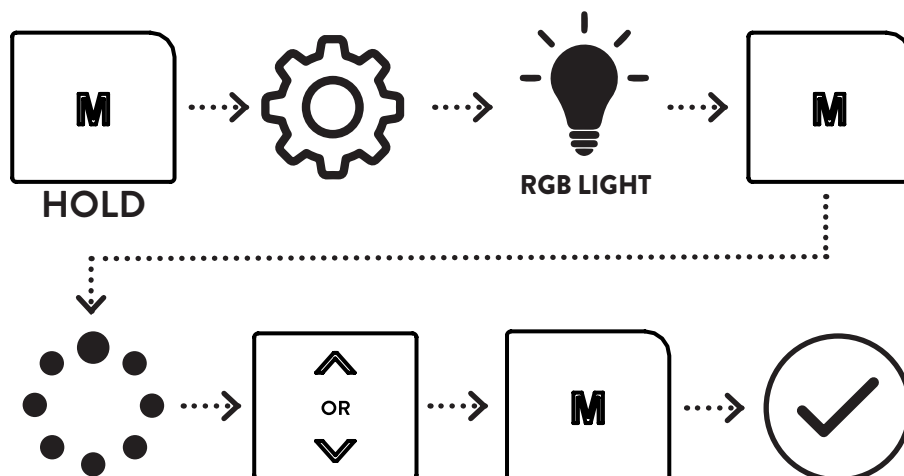

DESKY

PROGRAMMING CONTROLLER

Connecting your Controller to the Desky app

You can connect your controller to our app to easily adjust any of these functions or to track your standing goals. Download the Desky app on the Apple App Store or Google Play Store. To connect your Desky to your phone follow the instructions.

Steps:

1. Press any button to wake the controller. Hold the **M** button for 4 seconds. The display will show the spinning settings cog, wait until settings are launched.
2. Once the settings have been launched, navigate using the **UP** and **DOWN** arrow to the **BLUETOOTH** icon, press **M** to launch the setting.
3. In the app navigate to the add device / scan QR code icon and scan the QR code shown on the controller to connect the two devices.

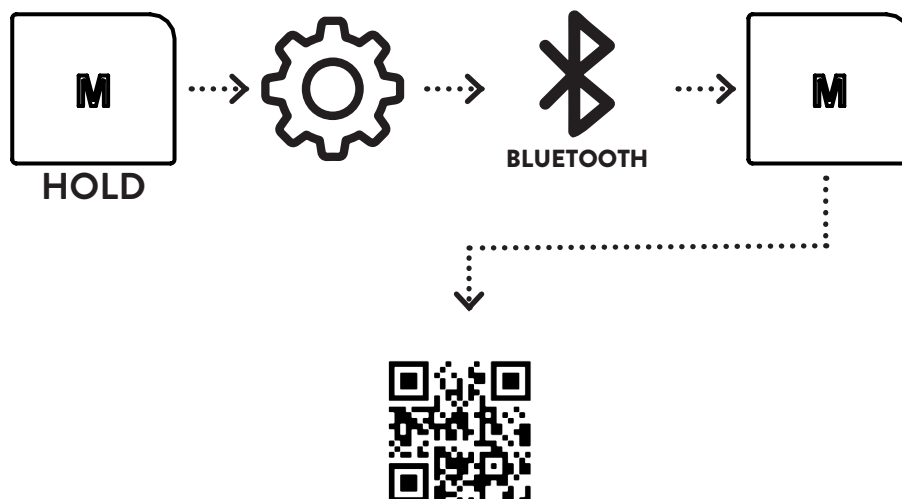

DESKY

VOICE COMMANDS

Activating Your Desk With Your Voice

To use voice control on your desky you must have the Desky app pre installed and connected to your controller via Bluetooth, see the previous step. *Note: your phone must be connected via Bluetooth to the hand controller for voice activation to work.*

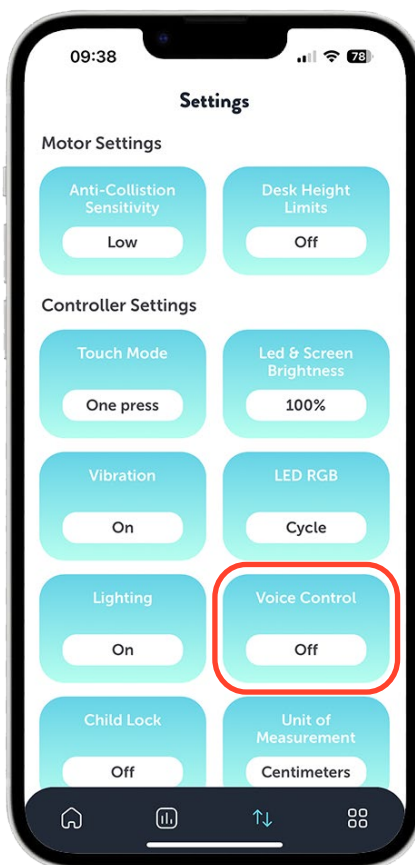

For Apple devices, voice control may be turned off initially. Once you have the app installed ensure that the voice control setting is switched on.

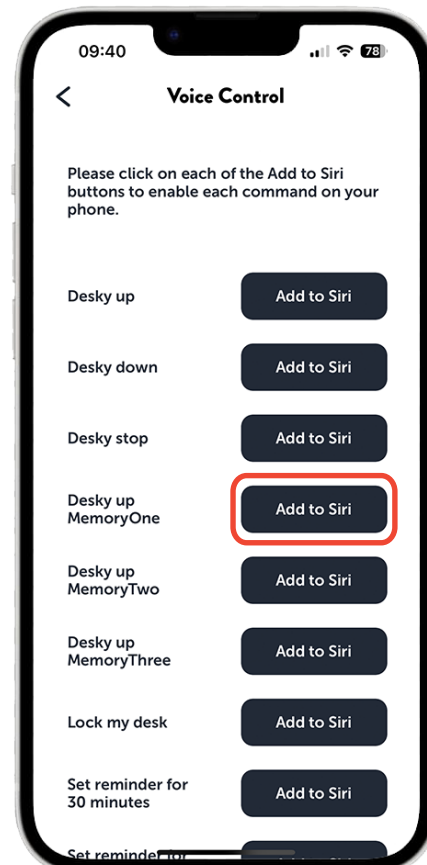

Once the voice control is turned on you can add or edit the preset phrases to perform the listed tasks. Siri will then register what you're saying and complete the task.

For instance you can add the 'Desky up MemoryOne' to Siri and follow the Siri instructions to edit it to your liking. E.g. "Hey Siri, raise my Desky to height one"

DESKY

VOICE COMMANDS

Voice Commands

Both operating systems use different phrases to execute the functions of your Desky. These phrases can be edited for Apple's Siri within the app (see previous step) however Google's phrases cannot be edited and require specific wording. The phrases for Google Assistant need to start with the words:

"Hi Google, open Desky and..."

Raise your desk:

*"...raise my desk"
"...raise the desk"
"...raise"*

Lower your desk:

*"...lower my desk"
"...lower the desk"
"...lower"*

Stop your Desk:

*"...stop my desk"
"...stop the desk"
"...stop"*

Set desk to saved height:

*"...set to height 1/2/3/4"
"...set my desk to height
1/2/3/4"*

Raise your desk to a height:

*"... set to 70/80/90/100
centimetres"*

Set a standing reminder:

*"...set a reminder for 30/45
minutes"
"...set a standing reminder
for 30/45 minutes"*

Lock your desk:

*"...lock my desk"
"...lock the desk"
"...lock"*

Unlock your desk:

*"...unlock my desk"
"...unlock the desk"
"...unlock"*

Turn the controller lights on/off:

*"... turn on the light"
"...turn off the light"*

If you experience any issues with your desk, the controller fails to activate the desk when operated, or displays an error message please first perform the following:

1. Check the cables are properly connected and secure. Check the cable from the controller to the control box, the power cable to the control box and the IC cables from each leg to the control box.
2. Check the feet and levelling studs to make sure the desk is sitting level.
3. Check the load on the desk (taking into account the weight of the desktop) does not exceed the desk's 140kg (308lbs) capacity.
4. Perform the Reset Procedure detailed on page 17.

Display Errors - Troubleshooting

H01: 'HOT' Overheating Error

- Cause: overheating can occur if the duty cycle of the motors in each leg are exceeded. The desk's electric motors require a duty cycle of 10%. A 2 minute on, 18 minute off duty cycle is required based on a continuous motor run time. Not observing the correct duty cycle can over heat the motors and reduce their lifespan.
- Troubleshooting: let the unit cool for 20 minutes and do not operate. Check the load in the desk does not exceed 140kg (308lbs). Perform the reset procedure.

E01 - E13: 'Firmware/ Connectivity Error

- Cause: cables are loose, not connected properly.
- Troubleshooting: check all cables are properly connected and secure. Perform the reset procedure.

If you continue to have issues with your desk after following the above troubleshooting and the reset procedure please contact us immediately.

Every DESKY product comes with a Limited Product Warranty. The duration and conditions of this warranty will vary depending on the product you have purchased.

The benefits under this warranty are in addition to other rights and remedies you may have under law in relation to goods or services sold by DESKY. Our goods come with gaurantees that cannot be excluded under the consumer law.

To view our full warranty policy please visit our website or contact us directly for more information.



DESKY

©2020 DESKY. All Rights Reserved