

PRO RAIN

Made by BAUER



USA

PRO RAIN

The efficient way to irrigate – compact, ec

F30 F40

Proven value

Fully automated irrigation by means of computer technology

Highly economical because of very low energy demand

Operational safety thanks to high quality components

Fully galvanized for long life

BAUER quality

Self leveling gun base

For gentle irrigation at the end of the strips and for uneven terrain

Automatic cart lift

At the end of the irrigated strip the cart is lifted into transport position

Hydraulic stabilizers

Easily operated, optimum stabilisation when lifting the cart

4 speed gearbox/turbine combination

Easy to handle, electronic control, for exact precipitation rates

Representative photo PRORAIN with accessories

onomical, flexible



PRO RAIN

A compact irrigation machine for different ground types



Ecostar 4000 S

Irrigation computer provides exact demand of required precipitation rate

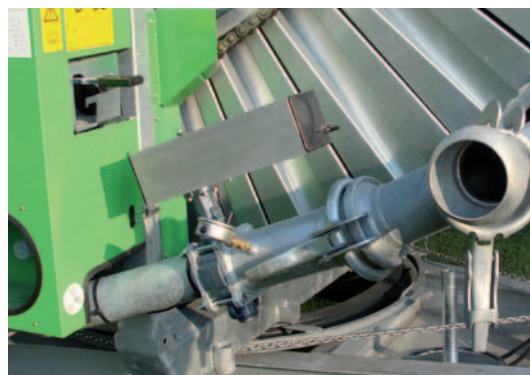

Shut-off valve

Optimum safety thanks to automatic shut-off of the system in case of over- or underpressure



Option: swivel aid – mechanical or hydraulic
For easy swivelling on uneven grounds

Basic unit	Model	PE-pipe ID x length (ft)	Irrigated width* (ft)	Irrigated length* (ft)	Irrigated area* (acres)	Flow rate range* (gpm)	Inlet pressure range (PSI)	Time to apply 1 inch acre**	Time per pull (hours)
F30	90 - 450	3.0" x 1475	276	1635	10.36	104 - 212	80 - 155	2.05	21.23
	100 - 400	3.3" x 1310	302	1485	10.30	113 - 292	80 - 155	1.47	15.15
	100 - 450	3.3" x 1475	292	1645	11.03	113 - 292	80 - 155	1.49	16.78
F40	100 - 540	3.2" x 1770	231	1935	12.39	104 - 231	80 - 155	2.03	25.13
	110 - 500	3.6" x 1640	302	1815	12.58	113 - 292	80 - 155	1.47	18.52
	120 - 370	3.9" x 1210	374	1395	10.09	173 - 374	80 - 155	1.21	12.23

* Detailed performance tables are available on request for every single model in combination with different Guns and nozzle diameters.
 Calculation based on max. flow rate. Performance is shown with Nelson Big Gun SR 150

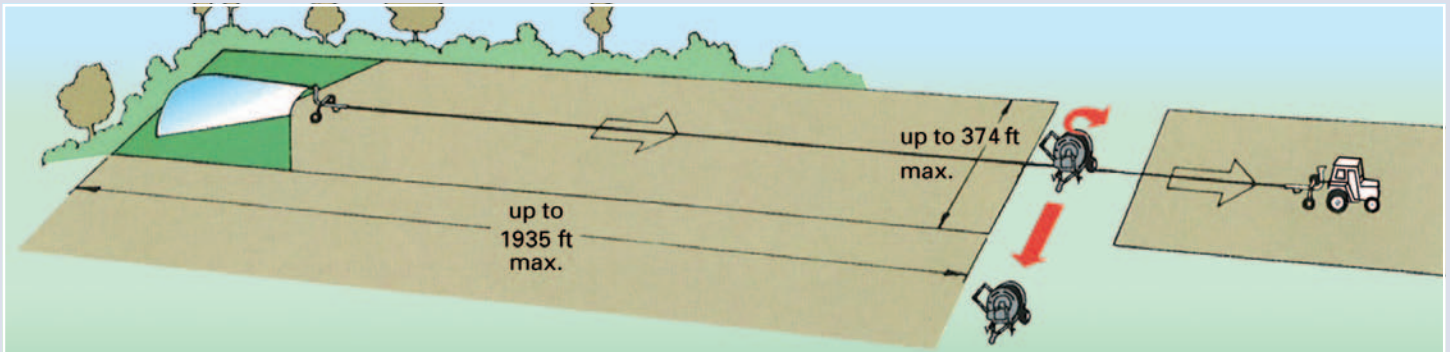

Dimensions F30 (F40)

All measurements in ft

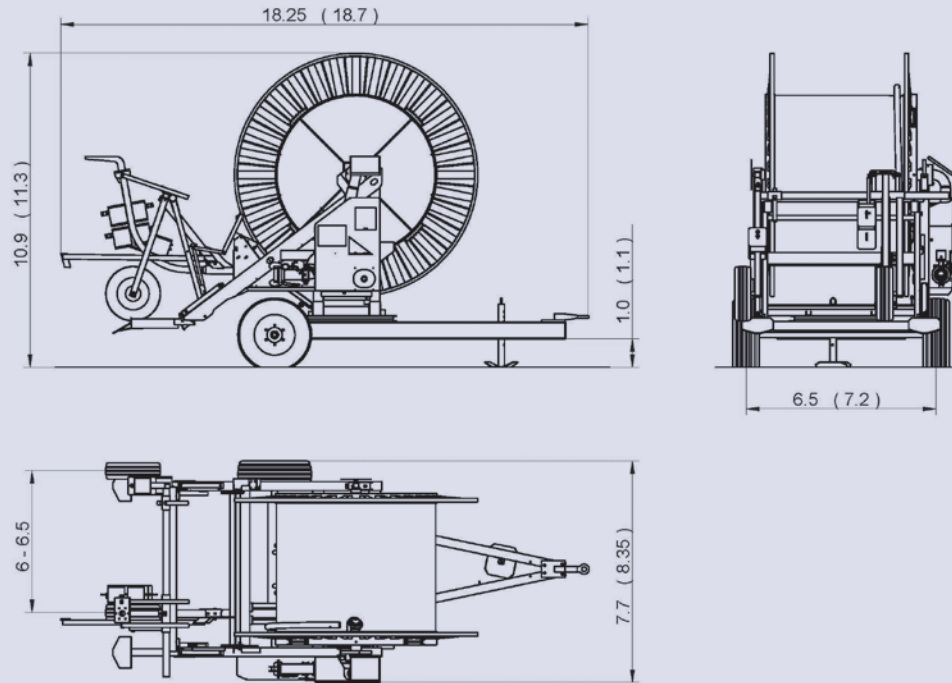

Presented by

BAUER GmbH, Röhren- und Pumpenwerk
 Kowaldstraße 2, 8570 Voitsberg, Austria
 T +43-3142-200-0, F +43-3142-200-320
 sales@bauer-at.com

BAUER North America
 Office: Michigan City
 T 1 - 800 - 922 - 8375
 sales@bauer-at.com

Subject to technical change • PRORAIN F30 / F40 • 08 2010