

LUMBERJACK TOOLS®

made in usa

Safe, Fast & Easy to Use

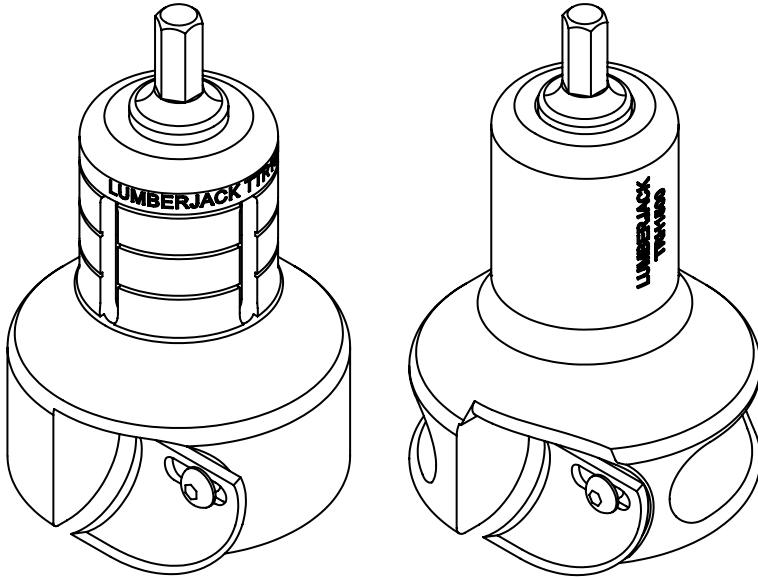

USER MANUAL

PRO™ & HOME™

Dual Blade Tenon Cutters

Works Like a Giant Pencil Sharpener®

All Rights Reserved.
© 2023 Lumberjack Tools
www.lumberjacktools.com
Email: info@lumberjacktools.com
Phone: 715-514-0319



MODELS:

Pro Series - TTR0500
Pro Series - TTR0750
Pro Series - TTR1000
Pro Series - TTR1500
Pro Series - TTR2000
Home Series - TRH1000
Home Series - TRH1500
Home Series - TRH2000

About Your Product

Thank you for purchasing our Dual Blade - Radius Shoulder Tenon Cutter! Lumberjack engineers, along with our craftsmen, have designed the safest, easiest-to-use tenon cutters on the market. By combining old-world skills with 3D CAD modeling and CNC manufacturing, we have created the ideal tenon cutter: straight tenons, smooth finish, precision operation, and long tool life.

Dual-bladed tenon tools will cut a tenon in half the time of a single-bladed tool. Wear is reduced by putting force of cutting across two blades instead of one. The blades are stamped, heat treated and precision ground to provide years of service if properly maintained. The Pro Series tools are machined from a solid aluminum billet and the Home Series tools are made of die-cast aluminum.



Our lifetime guarantee covers the tool body and shank. The blades are covered for breakage under normal working conditions for 90 days from the date of purchase. Blades will dull faster cutting hardwoods vs. softwoods (peeled or unpeeled). Soil and other abrasive substances will reduce blade life and are not covered under this warranty. When making a claim, you must show proof of purchase from an authorized distributor. This is valid only to the original buyer, not for tools sold secondhand, used, or sold "as is" to a second party.

What Voids Warranty

In order to keep our lifetime and 90 day warranty you must **AVOID** the following actions:

- Operating the tool in a drill press or lathe (or any system other than a hand-held drill)
- Running the tool into a nail or foreign object
- Altering or modifying the tool

SAFETY

Before beginning any project, carefully read and follow ALL safety and operational instructions for any tools or devices you will be using. Failure to do so may cause physical harm to yourself or those around you. If you feel uncomfortable using our tenon cutters or any other tool, STOP immediately. Lumberjack Tools assumes no responsibility for injury caused to the operator, bystander, or tools used in conjunction with the use or misuse of our tenon cutters.



NEVER OPERATE POWER TOOLS UNDER THE INFLUENCE OF DRUGS, ALCOHOL, OR ANY MEDICATIONS.



ALWAYS WEAR SAFETY GLASSES, DUST MASK, AND ANY OTHER PERSONAL PROTECTION ITEMS AS NEEDED.



NEVER WEAR LOOSE ITEMS THAT COULD BE CAUGHT IN MOVING PARTS. SECURE LOOSE OR LONG HAIR AWAY FROM AREA.



WE STRONGLY RECOMMEND A SINGLE-SPEED, GEAR DRIVEN DRILL WITH RPMS OF 500 OR LESS. EXCEEDING THESE RPMS MAY RESULT IN DAMAGE TO THE TOOL.



ALWAYS DISCONNECT POWER AND ALLOW DRILL TO COME TO A COMPLETE STOP BEFORE INSTALLING, REMOVING, OR ADJUSTING THE TOOL.



NEVER APPLY BENDING FORCE (SIDE LOADING) TO THE TOOL. SIDE LOADING COULD CAUSE THE SHANK TO FAIL, OR MAY RESULT IN BLADE DAMAGE.



ALWAYS SECURE THE LOG IN A VISE OR CLAMP PRIOR TO STARTING YOUR DRILL. FAILURE TO DO SO MAY RESULT IN INJURY.



ALWAYS HANDLE THE BLADES WITH EXTREME CARE! FAILURE TO DO SO MAY RESULT IN SERIOUS INJURY.



NEVER PUT HANDS OR ANY BODY PART INSIDE THE TOOL WHILE THE BLADES ARE ATTACHED! DOING SO MAY CAUSE SERIOUS INJURY.



WHEN EXCESSIVE FORCE IS REQUIRED TO CUT, RE-SHARPEN OR REPLACE THE BLADES. A SHARP TOOL IS A SAFE TOOL!

Pro Series ONLY

NOTE:

The Quick Stop Pins are not included with individual tools

Quick Stop Installation

1

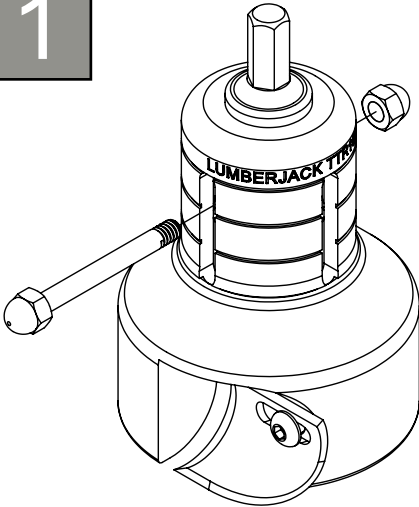

- Install the quick stop pin through the tool body
- Secure with the supplied acorn nut

NOTE:

For sale separately or included with kits

2

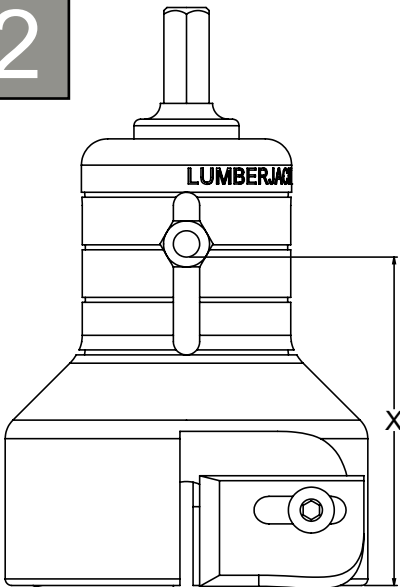

- The length of the tenon is determined by measuring from the face of the tool to the **bottom** of the Quick Stop Pin and subtracting $3/4$ "
- In the image to the left, dimension "X" - $3/4$ " = approximate length of the tenon

NOTE:

For sale separately or included with kits

Setting the Blades

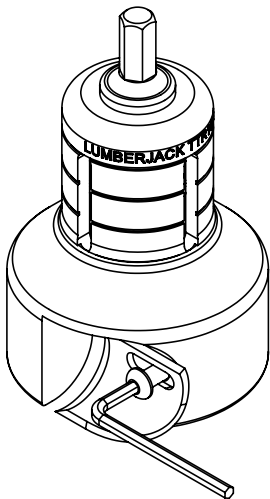

- Install and secure the blades with the Button Head Cap Screws
- Take your time and make sure blade offset/spacing is equal (see below)

Max Log Capacity	
Series	Max Dia.
TTR0500	2.00"
TTR0750	2.25"
TTR1000	2.50"
TTR1500	3.00"
TTR2000	3.50"
TRH1000	2.50"
TRH1500	3.00"
TRH2000	3.50"

Tip

- The cardboard box that the tool comes in is about 3/16"
- Remove a piece of the box to use as a quick spacer for blade setting

Cardboard Spacer

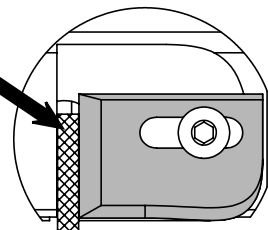

Blade Offset (Spacing)

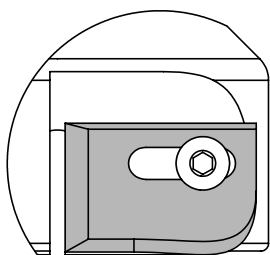

WRONG
(Blade too close)

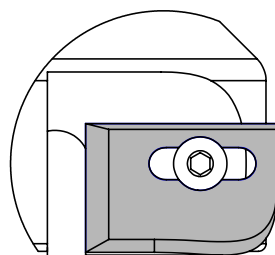

3/16"
Correct

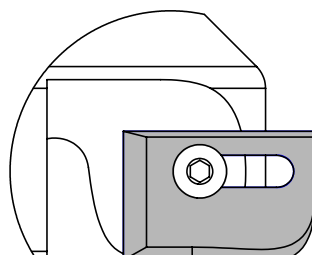

WRONG
(Blade too far)

It is critical that both blades have the same "offset". Blade offset refers to the gap size between the blade cutting edge and the side of the pocket. 3/16" is the standard gap size to use.

- The tool will not cut with 5/16" or greater spacing
- The tool will not cut with 1/16" or less spacing



Determine tenon length before cutting

- The key is to have a gap between the end of the tenon and bottom of the mortise hole
- This can be done by making the tenon $1/8''$ to $1/4''$ shorter than the mortise hole is deep

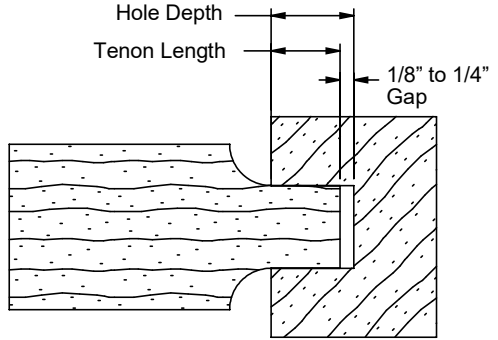

Calculated Tenon Length

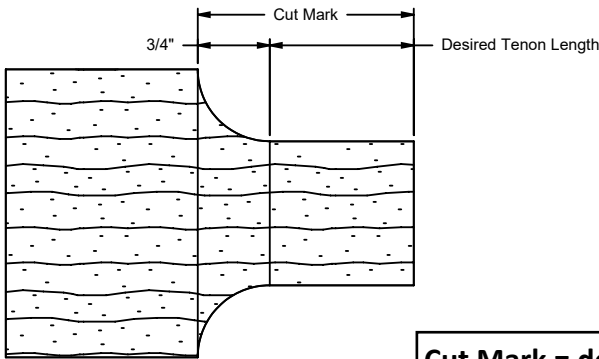

Gather the following information and use the calculation provided below:

- Desired tenon length

$$\text{Cut Mark} = \text{desired tenon length} + 3/4''$$

Simple Tenon Length

- Tenon length can be controlled without having the Industrial Series or Quick Stop Pins
- Cut off a piece of tenon to use as a plug to stop cutting at a set length

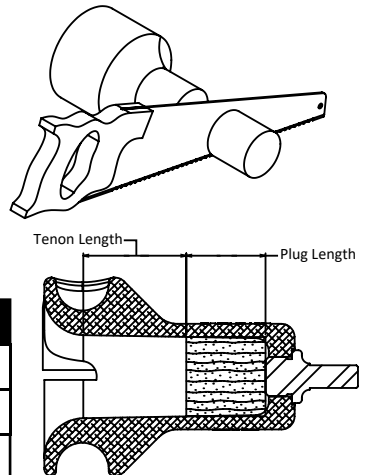

Series	Tenon Length
TRH1000	$2 \frac{1}{2}''$ – Plug Length
TRH1500	$3 \frac{1}{2}''$ – Plug Length
TRH2000	$4 \frac{1}{2}''$ – Plug Length

Cutting Tenons



WARNING: If the stock comes loose or unclamped while cutting, **DO NOT** drop the drill or try to grab the stock! Stop cutting and remove the tool from the end of the stock. Re-secure the stock, and resume cutting.

1

- Obtain the stock you want to cut
- Check that the diameter fits the tool capacity
- Cut stock to length and make sure the ends are flat. If the ends are not even/flat, the tenon will be crooked

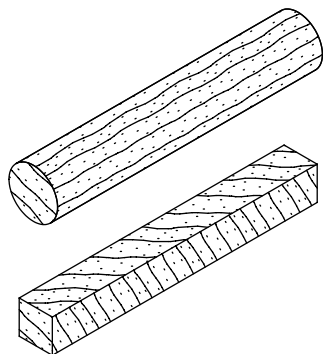

2

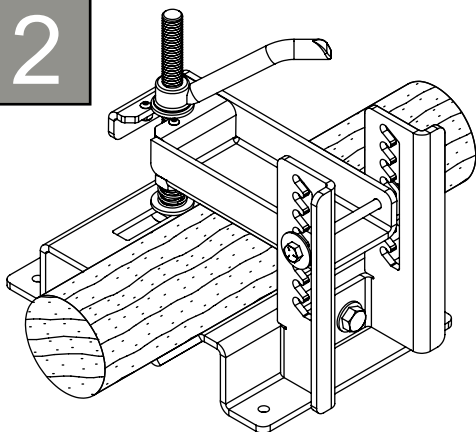

- Secure the stock in a vise, clamp, or fixture with a “V” shaped notch
- The **Log Lock (LL1545)** is a safe, easy, economical way to clamp material, and is available on our website

3

- If the diameter is larger than the tool can accept, taper the end with a hatchet or draw knife

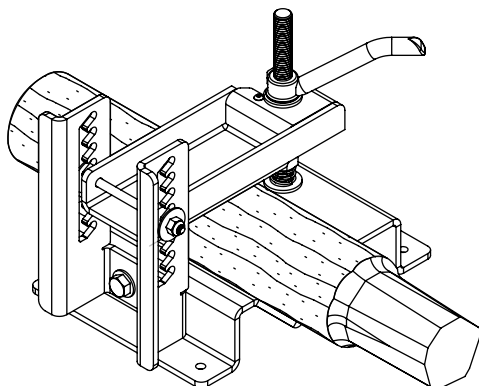

Cutting Tenons (cont.)



ALWAYS unplug the drill before adjusting the blades or adjusting the chuck.

4

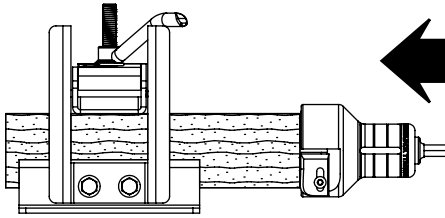

Maintain constant pressure

- Carefully install the tenon cutter into an unplugged 1/2" drill, and tighten it firmly by using the chuck key
- With the tool installed, square up to the stock so that the cutting face is flush with the end of the stock
- Apply body pressure by leaning against the back of the drill

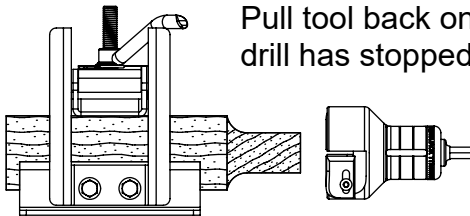

Pull tool back once drill has stopped

- Pull drill trigger to cut a tenon. Continue applying body pressure as the tool cuts
- Wait until the drill comes to a complete stop before removing the tool from the stock



- Make sure the tool is square against the end of the stock before cutting
- If the tool is held at an angle the tenon will be cut angled

4.5

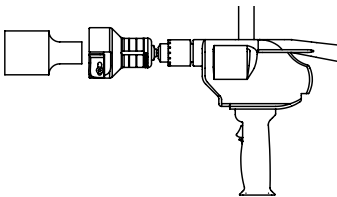

CORRECT

Drill in-line with log

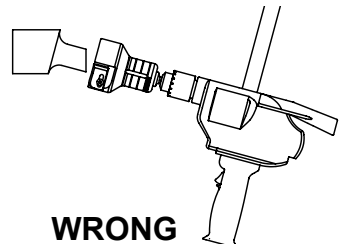

WRONG

Drill not in-line with log (crooked)

Drilling Holes (Mortise)

1



Tip

Measure and mark the locations of all holes before drilling

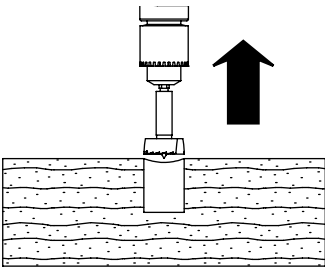
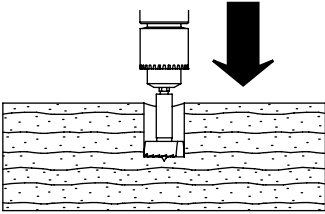
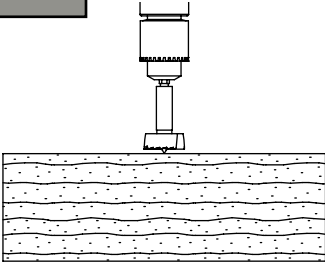

- Place the center of the bit on the desired hole location
- Hold the drill perpendicular to the log (unless angled holes are desired)
- Maintain constant pressure while drilling down
- Pull drill bit out in a controlled manner

We recommend using a forstner bit or self-feeding bit to drill the hole. Spade/paddle bits will work but cut rough.

2

- Drill mortise between $\frac{1}{3}$ and $\frac{1}{2}$ of the log diameter
- Do not drill more than $\frac{1}{2}$ of the log diameter unless a specific project calls for a deeper mortise

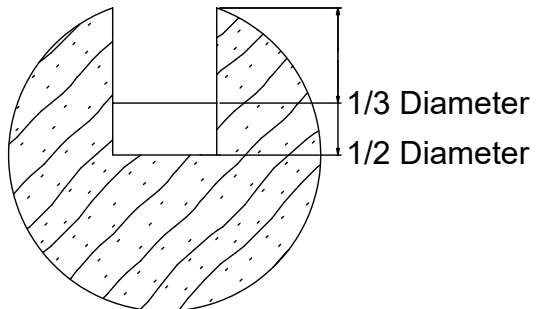

Maintenance

● Body

- Cleaning
 - Keep the tenon cutter body clear of sap and other build-up
 - Always remove the blades before cleaning
 - Clean the tool with a solvent (such as mineral spirits)



**WARNING: ALWAYS HANDLE THE BLADES WITH EXTREME CARE!
FAILURE TO DO SO MAY RESULT IN SERIOUS INJURY.**

● Blades

- Care
 - Always wipe blades with a thin film of oil at the end of the day to help prevent oxidation
- Cleaning
 - Clean the blades with a solvent (such as mineral spirits) and **immediately** apply a thin film of oil to prevent oxidation
- Sharpening
 - Use a sharpening stone, file or the **Blade Boss** (BB2575) to re-sharpen the blades, then clean the blades and apply a thin film of oil

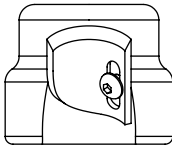

*Visit our website or call
for more information
about our Blade Boss*

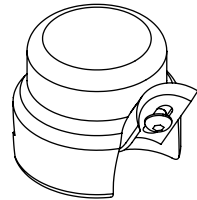

● Shank

- Replacement
 - If your shank breaks, we offer replacement shanks (see first page for contact information)
 - Turn the shank counter-clockwise to remove
 - Turn the shank clockwise to install

TASK	EACH USE	MONTHLY
Clean blade pockets	X	
Clean cutter bore	X	
Clean blades	X	
Inspect blades	X	
Oil blades	X	
Oil shank & screws		X

Troubleshooting

PROBLEM	CAUSE	SOLUTION
• Tool skips off to one side or bounces around	• Log is larger than tool will accept	• Taper down the end of the log with a draw knife
	• Not enough pressure is being applied	• Lean into drill with body
• Not cutting log	• Log is larger than tool will accept	• Taper down the end of the log with a draw knife
	• Blade offset too great	• See page 5
	• Blades are dull • Not applying enough pressure	• Sharpen blades • Purchase new blades • Lean into drill with body
• Takes too much of a "bite"	• Aggressive cutting from dual blades	• Remove one blade or "shim" blade up to .020"
• Crooked joint	• Holding drill crooked while cutting	• Position the drill square against the log before cutting
• Drill stops or cuts on small diameter logs but not larger ones	• Using a variable speed drill or drill not powerful enough	• We strongly recommend using a single-speed drill with low RPM and high torque
• Spiral grooves on the tenon joint	• Lateral wobbling of the drill	• Hold the drill steady while cutting
	• Removing the cutter while drill is still spinning	• DO NOT remove the cutter until the drill has come to a complete stop

Unexpected Occurrences

Engineers and Quality Control staff at Lumberjack Tools have provided you with one of the easiest to use and safest tenon cutters on the market. However, there is always the unexpected chance of failure.

- Please contact our customer support for a replacement if a failure ever occurs to the tool body, shank or blades

Thank you again for purchasing our tools!

BLADES SLIPPING?

If you encounter an issue with the blades slipping on your red Home Series Tenon Cutter, it may be due to the clear coat on the paint in the blade pocket.

TO RESOLVE THIS ISSUE, FOLLOW THE STEPS BELOW.



1. Remove the blades (**caution - sharp**)
2. Locate the blade pocket
3. Lightly sand off the clear coat with 150 grit sandpaper
4. Verify that the clear coat has a 'roughed up' surface - this allows the blade to have a better grip while cutting
5. Replace the blades and try cutting again to ensure it functions properly
6. Repeat Step 3 if necessary

Are you still experiencing issues? Call us at 715-514-0319.

3210 Hogarth Street, Eau Claire, WI 54703 • 715-514-0319
info@lumberjacktools.com • www.lumberjacktools.com