

THRU AXLE FORK MOUNT: NO SUB SPACERS SHOWN

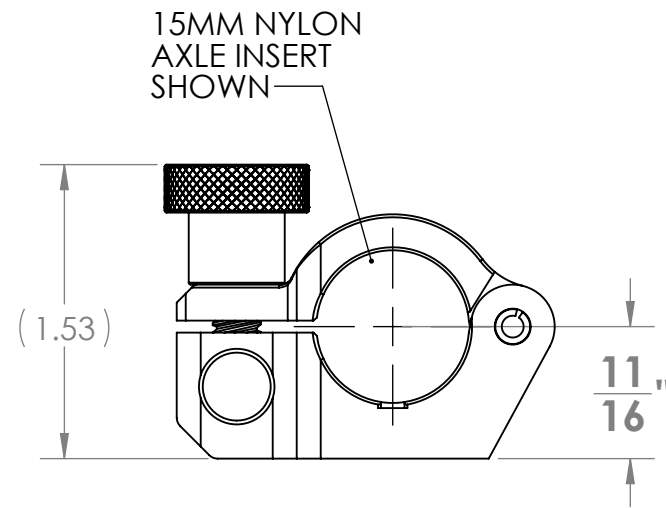
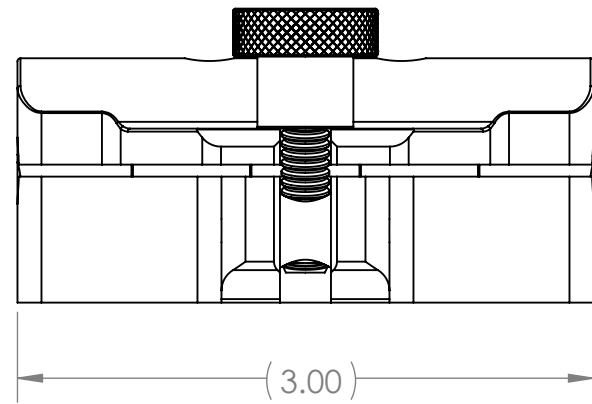
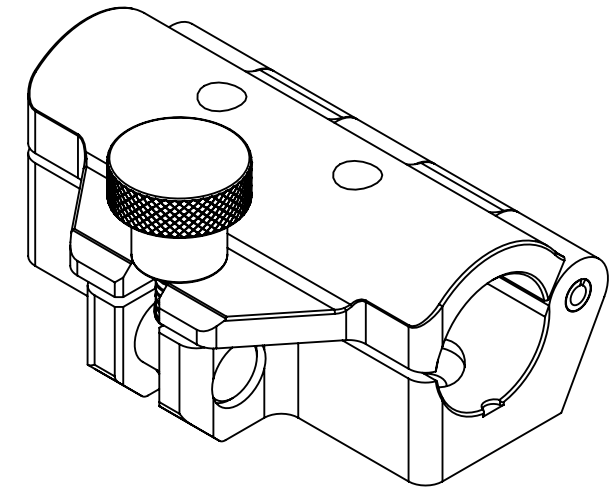
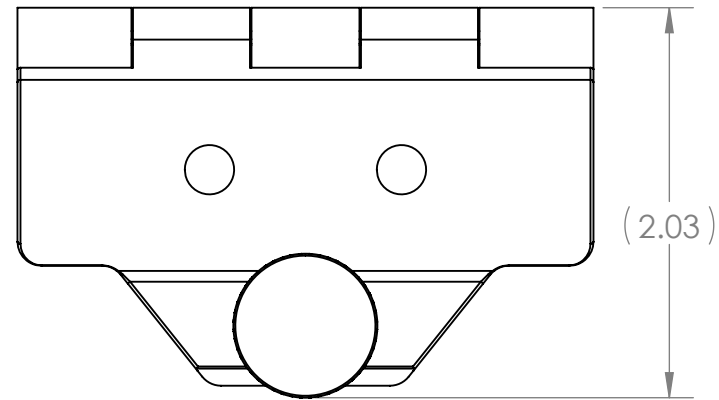

THIS IS THE LOWEST THRU AXLE FORK MOUNT ON THE MARKET. WITHOUT ANY SPACERS THE AXLE CENTER LINE IS ONLY 11/16" OFF OF THE MOUNTING SURFACE

UNLESS OTHERWISE SPECIFIED DIMENSIONS ARE IN INCHES

TOLERANCES:
 ANGULAR: ±0.5°
 ONE PLACE DECIMAL: ±0.1
 TWO PLACE DECIMAL: ±0.01
 THREE PLACE DECIMAL: ±0.005

PROPRIETARY AND CONFIDENTIAL
 THE INFORMATION CONTAINED IN THIS DRAWING IS THE SOLE PROPERTY OF SIXTH ELEMENT ENGINEERING. ANY REPRODUCTION IN WHOLE OR IN PART WITHOUT THE WRITTEN PERMISSION OF SIXTH ELEMENT ENGINEERING IS STRICTLY PROHIBITED.

DO NOT SCALE DRAWING

	NAME	DATE
DRAWN	---	---
CHECKED	---	---

TITLE:
LOW PROFILE FORK MOUNT

SIZE B	DWG. NO. 1000-MA10-00	REV
------------------	--------------------------	-----

SCALE: NTS	SHEET 2 OF 5
------------	--------------



THRU AXLE FORK MOUNT: OPEN POSITION NO SUB SPACERS OR INSERTS SHOWN

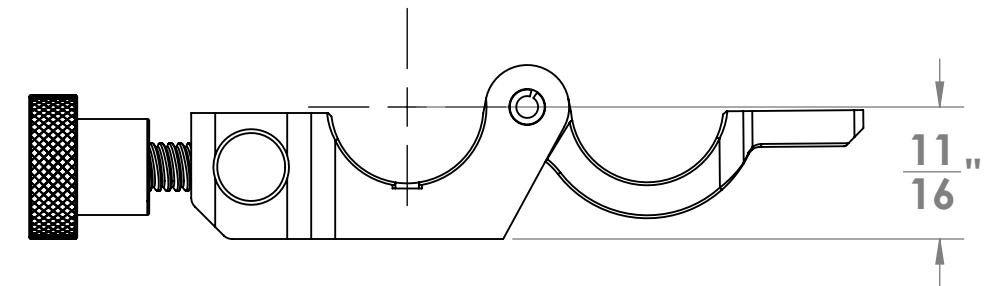
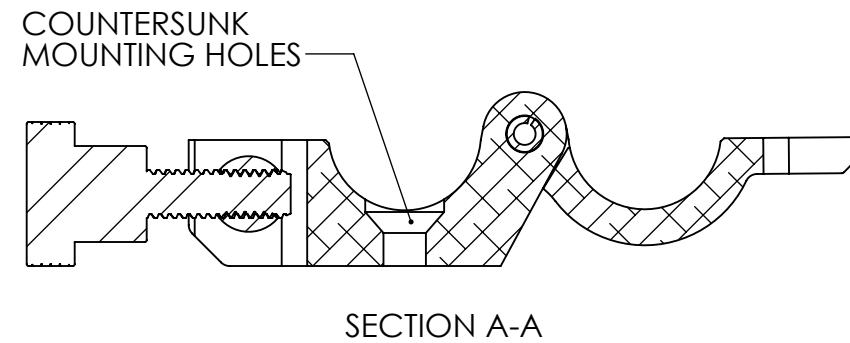
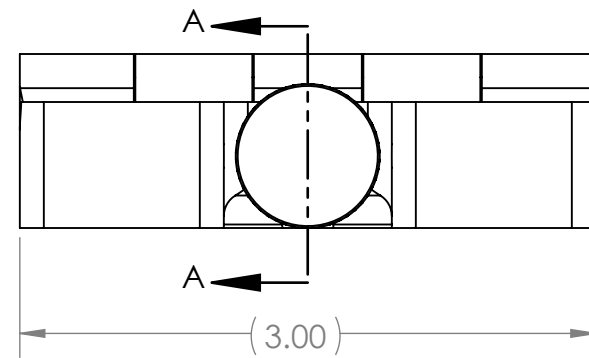
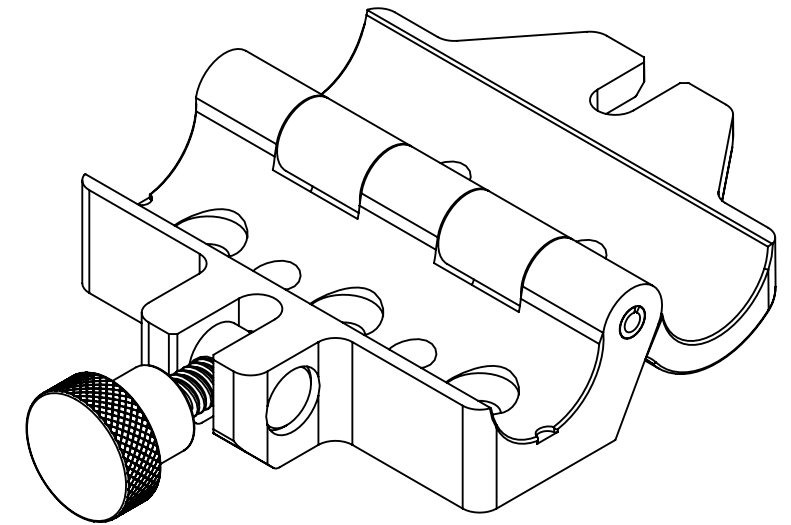
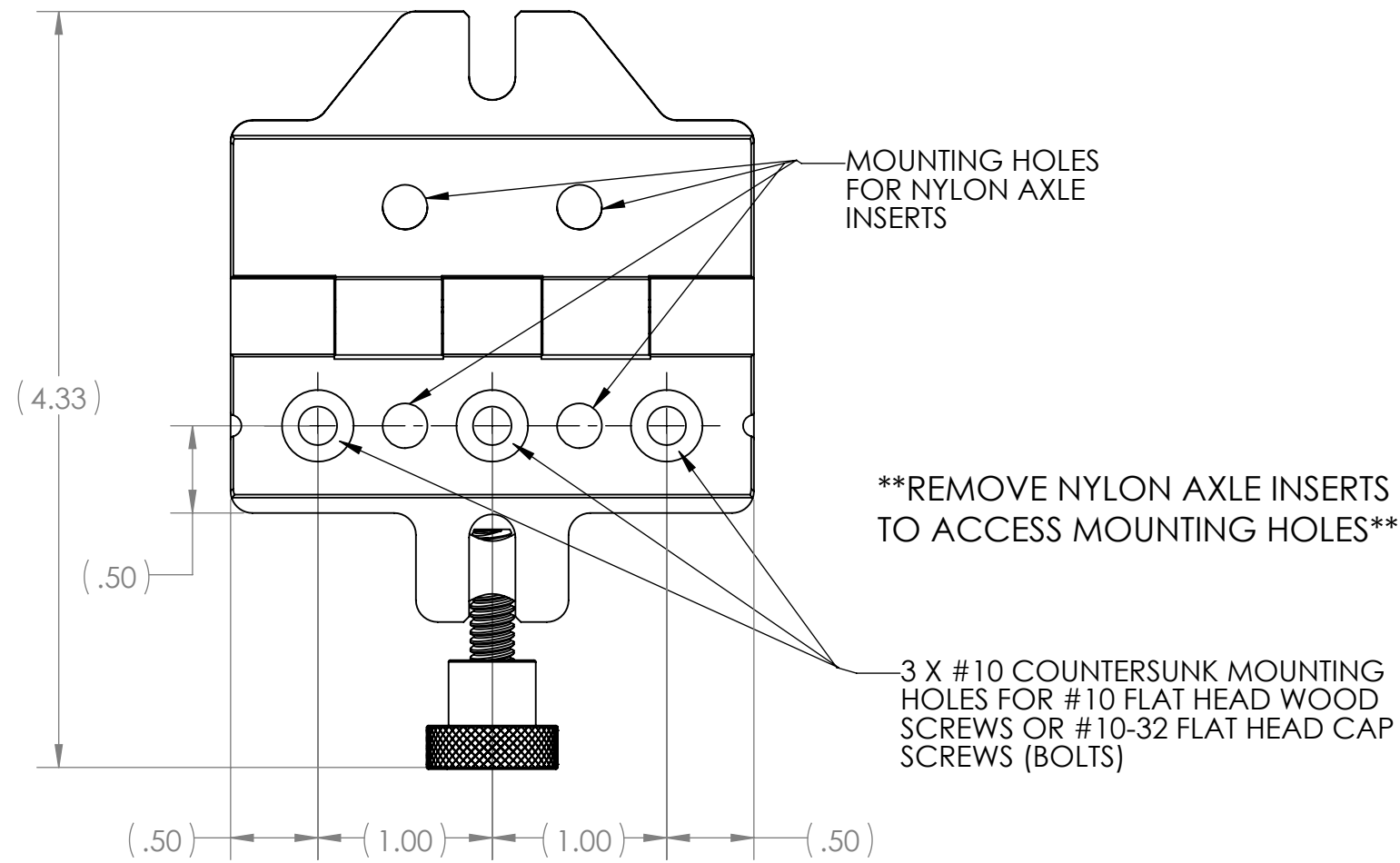

UNLESS OTHERWISE SPECIFIED DIMENSIONS ARE IN INCHES

TOLERANCES:
ANGULAR: ±0.5°
ONE PLACE DECIMAL: ±0.1
TWO PLACE DECIMAL: ±0.01
THREE PLACE DECIMAL: ±0.005

PROPRIETARY AND CONFIDENTIAL
THE INFORMATION IN THIS DRAWING IS THE SOLE PROPERTY OF SIXTH ELEMENT ENGINEERING. ANY REPRODUCTION IN WHOLE OR IN PART WITHOUT THE WRITTEN PERMISSION OF SIXTH ELEMENT ENGINEERING IS STRICTLY PROHIBITED.

DO NOT SCALE DRAWING

	NAME	DATE
DRAWN	---	---
CHECKED	---	---



TITLE:
LOW PROFILE FORK MOUNT

SIZE B	DWG. NO. 1000-MA10-00	REV
------------------	--------------------------	-----

SCALE: NTS	SHEET 3 OF 5
------------	--------------

THRU AXLE FORK MOUNT: SUB SPACERS SHOWN

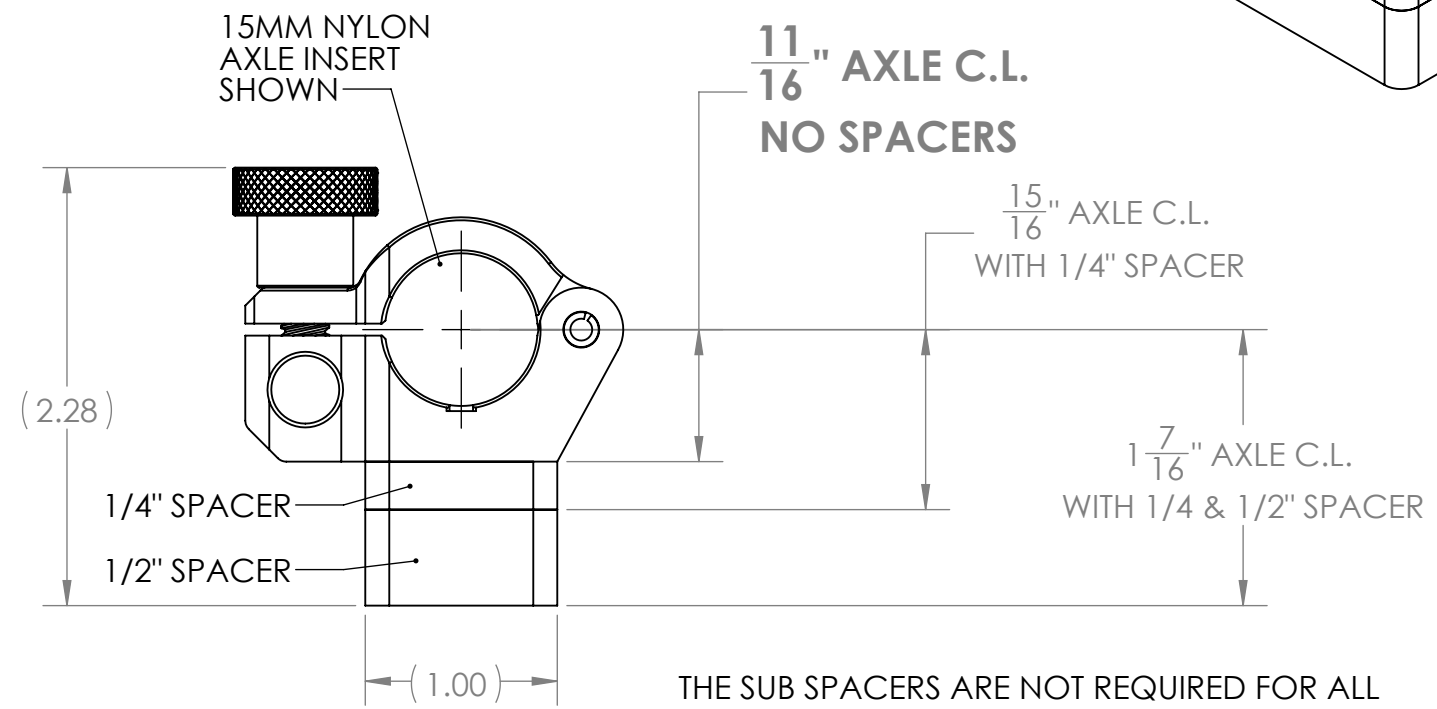
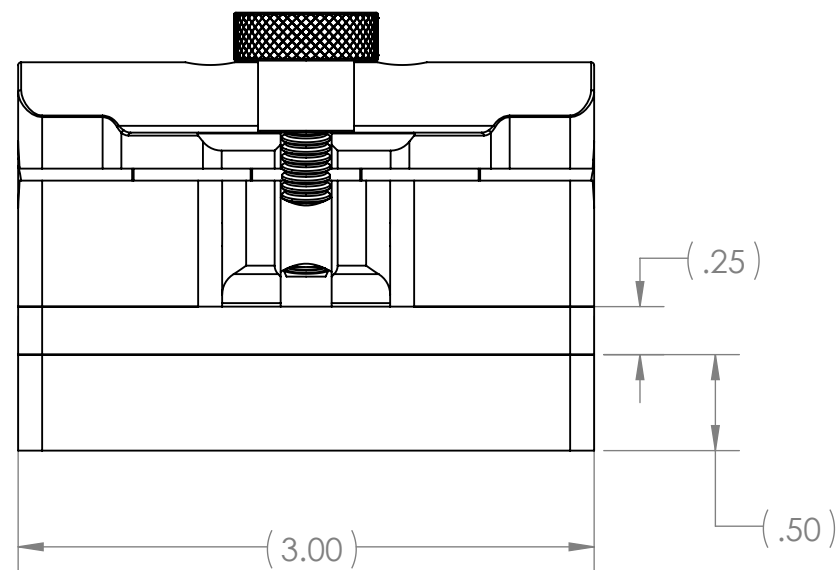
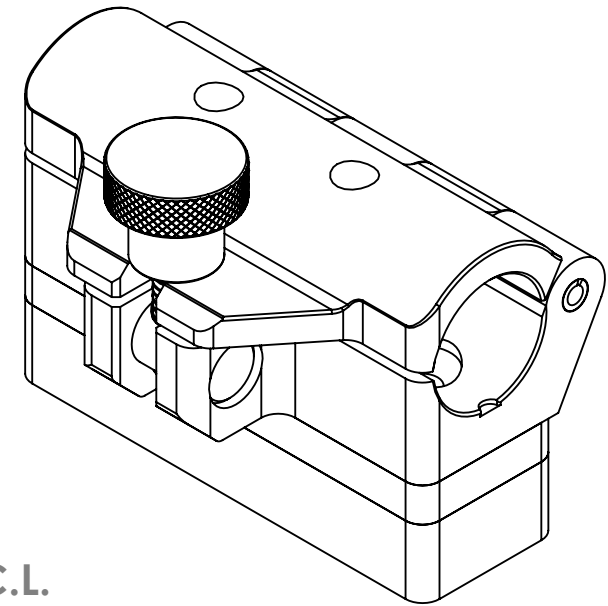
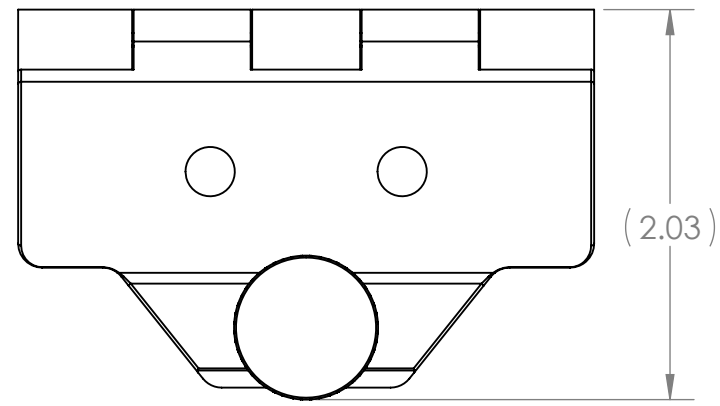

THE SUB SPACERS ARE NOT REQUIRED FOR ALL INSTALLATIONS. THESE ARE PROVIDED JUST IN CASE THEY ARE NEEDED. THEY CAN BE MIXED AND MATCHED TO RAISE THE FORK MOUNT BY 1/4", 1/2", OR 3/4" WHEN BOTH SPACERS ARE USED TOGETHER

UNLESS OTHERWISE SPECIFIED DIMENSIONS ARE IN INCHES TOLERANCES: ANGULAR: ±0.5° ONE PLACE DECIMAL: ±0.1 TWO PLACE DECIMAL: ±0.01 THREE PLACE DECIMAL: ±0.005	DO NOT SCALE DRAWING		TITLE:	
	NAME	DATE	LOW PROFILE FORK MOUNT	
PROPRIETARY AND CONFIDENTIAL THE INFORMATION IN THIS DRAWING IS THE SOLE PROPERTY OF SIXTH ELEMENT ENGINEERING. ANY REPRODUCTION IN WHOLE OR IN PART WITHOUT THE WRITTEN PERMISSION OF SIXTH ELEMENT ENGINEERING IS STRICTLY PROHIBITED.	DRAWN	---	---	SIZE
	CHECKED	---	---	DWG. NO.
			---	---
SCALE: NTS			1000-MA10-00	SHEET 4 OF 5

THRU AXLE FORK MOUNT: OPEN POSITION WITH SUB SPACERS SHOWN

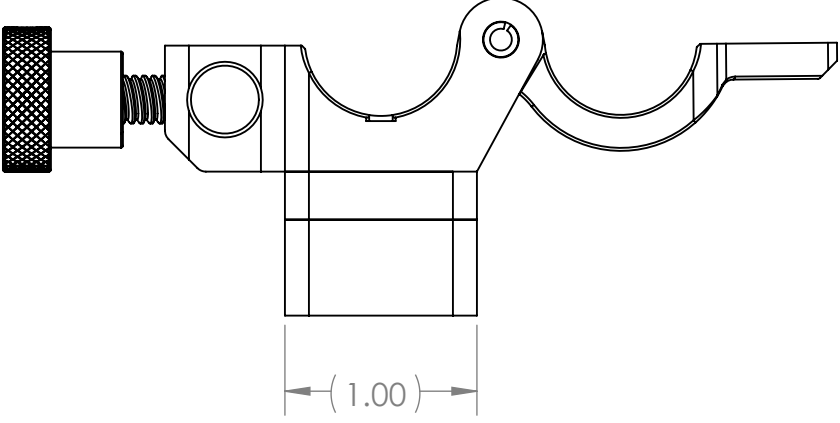
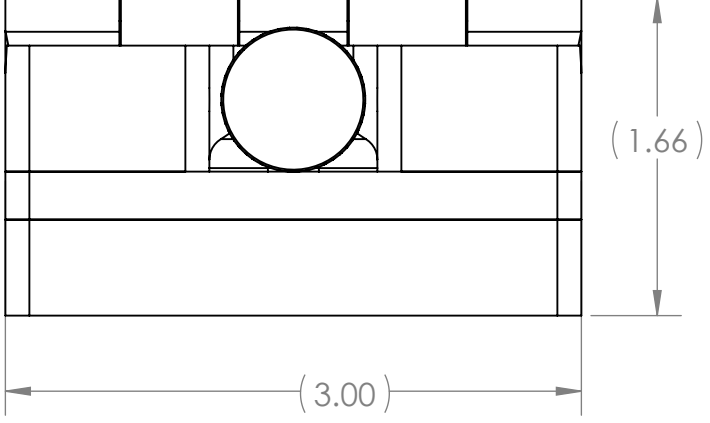
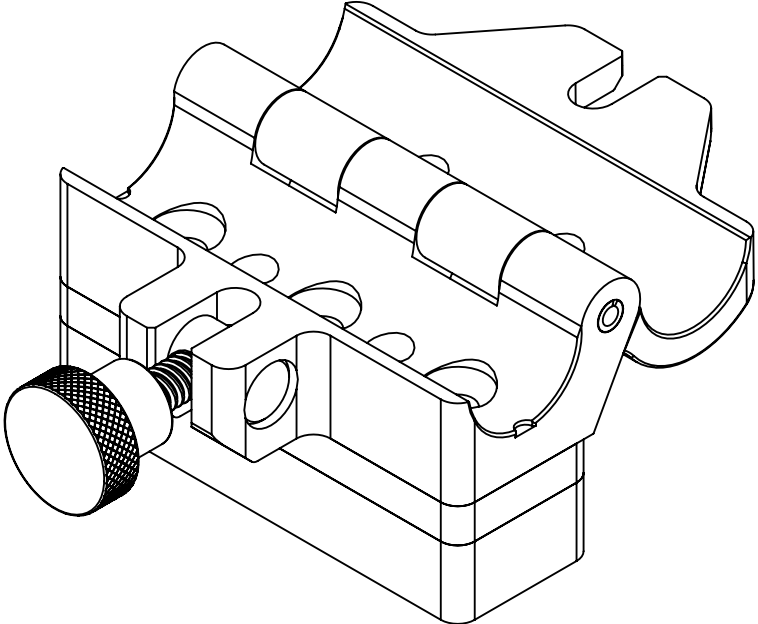
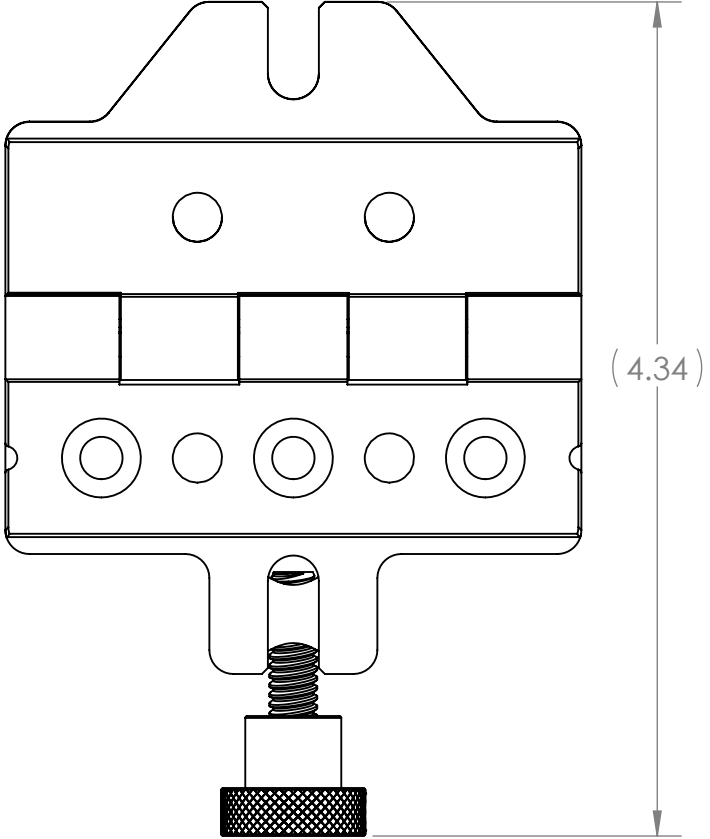

MOUNT SHOWED IN OPEN POSITION

<p>UNLESS OTHERWISE SPECIFIED DIMENSIONS ARE IN INCHES</p> <p>TOLERANCES: ANGULAR: ±0.5° ONE PLACE DECIMAL: ±0.1 TWO PLACE DECIMAL: ±0.01 THREE PLACE DECIMAL: ±0.005</p>	DO NOT SCALE DRAWING		TITLE:									
	<table border="1"> <thead> <tr> <th></th> <th>NAME</th> <th>DATE</th> </tr> </thead> <tbody> <tr> <td>DRAWN</td> <td>---</td> <td>---</td> </tr> <tr> <td>CHECKED</td> <td>---</td> <td>---</td> </tr> </tbody> </table>		NAME	DATE	DRAWN	---	---	CHECKED	---	---		
	NAME	DATE										
DRAWN	---	---										
CHECKED	---	---										
<p>PROPRIETARY AND CONFIDENTIAL</p> <p>THE INFORMATION CONTAINED IN THIS DRAWING IS THE SOLE PROPERTY OF SIXTH ELEMENT ENGINEERING. ANY REPRODUCTION IN WHOLE OR IN PART WITHOUT THE WRITTEN PERMISSION OF SIXTH ELEMENT ENGINEERING IS STRICTLY PROHIBITED.</p>			SIZE	DWG. NO.	REV							
			B	1000-MA10-00								
SCALE: NTS			SHEET 5 OF 5									