



Installation Instructions:

Transit 8020 Roof Rack Kit

148 WB Mid Roof, 148 WB High Roof, & 148 WB High Roof Extended



Revision: 0
Date: 6-5-2023

The Unaka Gear Co Team is here to help. If you have issues or questions, please do not hesitate to contact us at info@unakagearco.com.

Contents

1. Disclaimers	4
2. Overview	4
3. Other Manuals / References	4
4. Safety	4
5. Required Tools	5
5.1. Tools Required for Unaka Roof Rack Brackets	5
5.2. Suggested or Example Tool Options	5
6. Required Materials.....	6
6.1. Anti-seize and Loctite.....	6
7. 8020 Rack Accessories	7
8. Roof Rack Kit Installation	7
8.1. Bolts, Washers, T-nuts, and Hardware:	7
8.2. Assembly Sequence	7
8.3. Layout the Rack Kit.....	8
9. Rack Bracket Installation Summary	9
10. Roof Rack Bracket Locations	9
10.1. 148” WB Roof Rack Bracket Locations.....	9
10.2. 148” WB Extended Length Roof Rack Bracket Locations.....	10
11. Roof Rack Bracket Installation Steps.....	11
11.1. Transit Standard Roof Rack Bracket Installation.....	11
11.2. Transit 148” Ext. Length Rear Roof Rack Bracket Installation	14
12. Side Rail Installation.....	16
12.1.1. Side Rail Mounting for 56.125” Lg. Cross Bars.....	16
12.1.2. Side Rail Mounting for 59.625” Lg. Cross Bars.....	17
12.1.3. Side Rail Layout	18
12.1.4. Install the Side Rails	19
12.2. Loosely Assemble Cross Bar Assemblies.....	23
12.3. Use 8020 Cross Bar Assemblies to Position and Tighten 8020 Side Rail Assemblies.....	25
12.4. Install 8020 Cross Bar Assemblies.....	27
12.4.1. Install Front Cross Bar	28
12.4.2. Install Additional Cross Bars.....	28
12.5. Tighten Remaining Hardware & Seal Brackets	29

12.5.1.	Unaka Ford Roof Rack Brackets:	29
12.5.2.	Seal Unaka Ford Roof Rack Brackets:.....	29
12.5.3.	8020 Rack Kit Hardware:.....	30
12.6.	Preventative Maintenance Checks	30

1. Disclaimers

Installation: The installation should be performed by qualified persons only.

Roof Rack Load Rating: Unaka Gear Co. encourages all customers to follow the vehicle manufactures guidelines with respect to the load capacity of their van roof. If the load capacity of the van roof is exceeded, this will void any warranty with respect to the roof rack.

Roof Top Decks: Unaka Gear Co. does not recommend building any sort of roof deck platform on your van roof. Vehicle roofs are high above the ground and any sort of fall can result in serious injury or death.

2. Overview

This set of instructions is a basic guideline on how to install your Ford Transit 8020 Roof Rack Kit for the 148" WB and the 148" WB Extended High Roof Ford Transits. Since our kits are designed to be flexible for DIY projects this set of instructions may not cover everything for your specific installation. If you have questions or issues with our product do not hesitate to contact us at csr@unakagearco.com.

3. Other Manuals / References

If you have not already done so, please review all other relevant rack bracket, rack kit, or rack accessory manuals before starting your installation. There may be information covered in those manuals which may help clarify or provide tips to make the installation of your kit easier. These manuals are located here: <https://unakagearco.com/pages/manuals>

4. Safety

Working with tools involves inherent risks that could result in injury or in extreme cases death. It is important to know how to perform the job and perform it safely. Always use the correct tools for the job and wear the required personal protective equipment (PPE) necessary for the job. If you are unsure of how to complete a task safely consult a friend or a professional. Below are some suggestions for PPE to help stay safe but as individuals may approach a job differently, they may need to adjust the required PPE accordingly.

Suggested PPE:

- Safety Glasses
- Gloves
- Hearing Protection

Ladder Safety: Ladders are dangerous and should only be used with appropriate training in addition to following the ladder manufactures usage instructions. Incorrect use of ladders can result in injury or death. Installing a roof rack will require the use of one or more ladders and the location of these ladders will have to be moved to varying positions during the installation. Always take the extra time to move the ladder to appropriate position to ensure that you do not have to lean or reach out while on the ladder. We highly recommend having someone hold or stabilize the bottom of the ladder while someone is working from it.

Fall Protection: Accessing the roof of your van will put you at extreme risk to potential falls which can result in injury or death. Appropriate fall protection should be used when accessing your van roof. For general use situations, OSHA requires that fall protection be provided at elevations of four feet in general industry workplaces.

5. Required Tools

The following tools or a combination of these tools should be used for this installation. Proper knowledge on how to use these tools is required. No tools are provided with the kit.

5.1. Tools Required for Unaka Roof Rack Brackets

- Standard & Metric Socket Set
- Standard & Metric Wrench Set
- Torque Wrench (Must go up to 144 in-lbs. or 12 ft-lbs. and be compatible with a ½" socket)
- Standard Allen Wrench Set (must include 3/16" Allen Key)
- Torque Wrench (Must go up to 180 in-lbs. or 15 ft-lbs. and be compatible to use with 3/16" Allen Key)

5.2. Suggested or Example Tool Options

- [¼" Drive Torque Wrench, 40 in/lbs. to 200 in/lbs.](#) (The key is to make sure the torque wrench you use has the appropriate torque range)
- [1/4 in. Drive \(F\) x 3/8 in. \(M\) Adapter](#) (This will allow you to use the ¼" drive torque wrench with 3/8" drive sockets or other accessories)
- [3/8 in. Drive SAE Hex Bit Socket Set \(7-Piece\)](#) (The 3/16" Allen should be the only size required for this job but sometimes it is easier to purchase an entire set. This will work with your torque wrench, and any socket wrench with a 3/8" drive or a ¼" drive plus the adapter above)
- T-handle Ball End Hex Wrench, 3/16" (This will make installing the bolts and t-nuts much easier than using a standard Allen wrench)
- Ball End Hex Driver, 3/16" (Works well in addition to the t-handled listed above)



Torque Wrench



3/8 in. Drive SAE Hex Bit
Socket Set (7-Piece)



1/4" Female to
3/8" Male Drive
Adapter



T-handle Ball End
Hex Wrench, 3/16"



Ball End Hex
Wrench, 3/16"

Images above not shown to scale

Figure 1: Suggested tool example pictures

6. Required Materials

- Dicor RV Roof Lap Sealant or similar UV resistant sealant
- Blue 242 Loctite (Use on all bolts going into T-nuts, or regular nuts)
- Antiseize (Use on any bolt going into a nylock nut, this is mainly important for wind fairing or flush mount solar panel bracket installations)
- Unaka 8020 Rack Kit

6.1. Anti-seize and Loctite

Applying a small dab of anti-seize to the side of a stainless steel bolt before putting the nut on helps minimize the chance for galling or seizing. Stainless steel hardware resists the elements that your wind fairing will be exposed to, but it has one down side. Stainless steel hardware is prone to galling and then seizing up during assembly, especially when using nylock nuts. If this happens, the bolt typically has to be cut or broken off and then you have to try again.

Loctite & Anti-seize

Follow manufactures recommendation for application and safety.

Blue Loctite 242 (Not Included with Kit)

- Apply this to any bolt that is not used with a nylock nut

Loctite Anti-seize (Included with Kit)

- Apply a dab of anti-seize to the side of each bolt that will be paired with a nylock nut. Nylock nuts have a small plastic insert to make them vibration resistant.



Loctite 242



Loctite C5-A Anti-Seize

7. 8020 Rack Accessories

Most likely you are building your rack to install solar panels, a deck, or maybe you have other plans. The following accessories help increase functionality, improve the installation process, and give it the finishing touches your van truly deserves. If you haven't checked these out you should, just click the links below!

[Flush Mount Solar Panel Brackets](#)

[Unaka Transit Wind Fairing](#)

8. Roof Rack Kit Installation

****Important:** Read all the directions below before beginning your installation!

8.1. Bolts, Washers, T-nuts, and Hardware:

DO NOT MIX Hardware Kits unless you are sure something is interchangeable!!!! Even though many of the pieces of hardware look very similar, do not mix bags of hardware unless you are certain they are the same size and length. In some cases, some bolts may only be 1/16" longer than others, so it can be very easy to get hardware mixed up and then to have issues assembling the kit later.

8.2. Assembly Sequence

This section goes over a high-level assembly process to put your rack together. All of these steps are explained in more detail in the later sections.

1. Review this entire manual before starting the process.
2. Layout the rack kit
3. Prep the roof for bracket installation (remove / expose mounting holes in Transit roof)

4. Loosely install the Unaka rack brackets
5. Loosely install the 8020 side rail assemblies
6. Use the 8020 cross bar assemblies to set the spacing for final side rail and roof rack bracket installation. Tighten roof rack brackets & Dicor / seal them
7. Final install the 8020 cross bar assemblies along with any additional accessories selected.
8. Tighten all brackets and hardware.

8.3. Layout the Rack Kit

Before beginning the assembly process, layout the entire rack kit in an open area as it would be installed on the van. Do not bolt anything together, just lay the items out where they will be used.



Figure 2: Layout rack on floor including hardware, label parts, hardware quantity, and locations as needed. *Note image above is from a different rack kit

- Layout all items including the wind fairing, Unaka roof rack brackets, flush mount solar panel brackets, and all the 8020 brackets and material.
- If you choose to layout the bolts and nuts along with the extrusion and brackets, make sure the surrounding area is clean so that you do not lose any of your hardware.
- Write down or make notes of which brackets get how many pieces of hardware so that when it is time to complete the install you insert the correct number of nuts into the extrusion for that part of the build.

TIP: We highly recommend labeling the parts you layout. As you move these parts from the ground to your roof this will help minimize the potential of leaving t-nuts out or putting them on the wrong face. For this step, you may even choose to use some painters tape to mark or annotate the quantities of hardware required for each location.

9. Rack Bracket Installation Summary

Figure 3 shows a detailed breakdown of the parts that make up a set of Unaka mounting brackets. Note each Set of brackets that you order from Unaka comes with two complete mounting brackets and associated hardware.



Figure 3: Unaka rack bracket component breakdown

Tips:

- During the initial fit up of the Unaka brackets, leave the hardware loose.
- Wait to tighten the hardware until after the side rails are in place and cross bars can be used to align / set the spacing between the side rails.

10. Roof Rack Bracket Locations

The information below highlights where the Ford Transit Brackets are typically installed.

10.1. 148" WB Roof Rack Bracket Locations

The mounting locations on the standard transit are straight forward but are highlighted below.

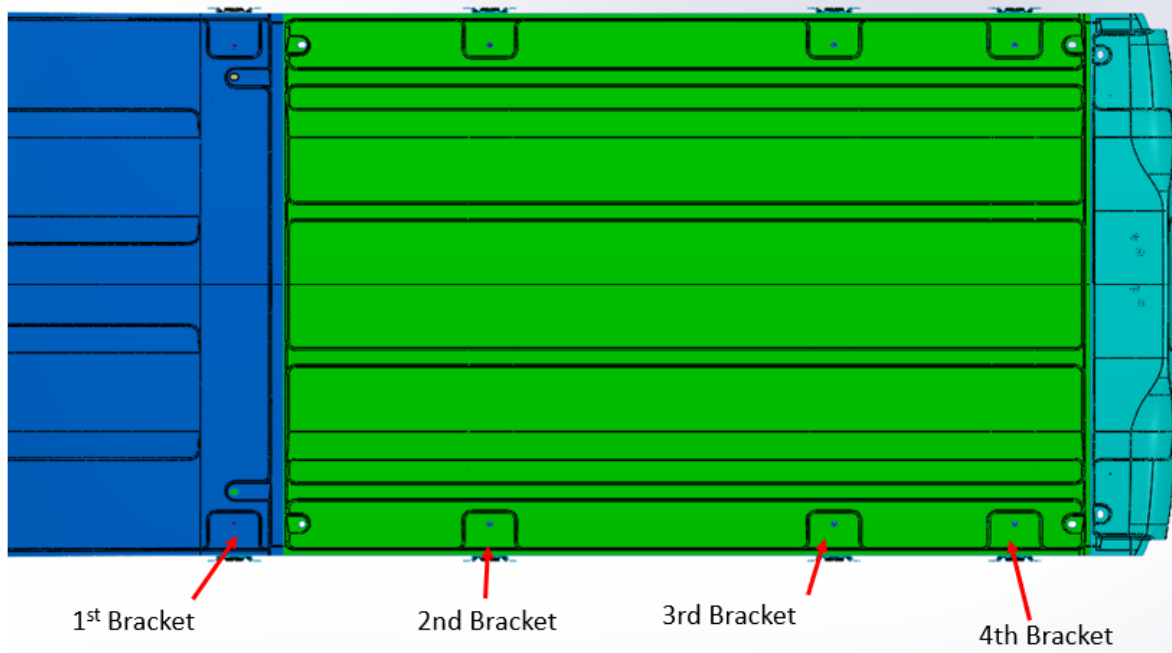

Figure 4: 148" WB roof rack bracket locations

10.2. 148" WB Extended Length Roof Rack Bracket Locations

The Ford Transit 148" WB Ext. Length van has five standard mounting locations, and one rear mounting position which uses a slightly different bracket, Figure 5. The installation of this rear bracket is covered in section 11.2. The 8020 kit comes with 4 standard brackets, and one rear bracket for each side of the van. Our 8020 Ford Transit Rack kits use mounting points 1, 2, 3, 5, and the rear bracket. We skip the fourth position as it is so close to the fifth position which better distributes the load.

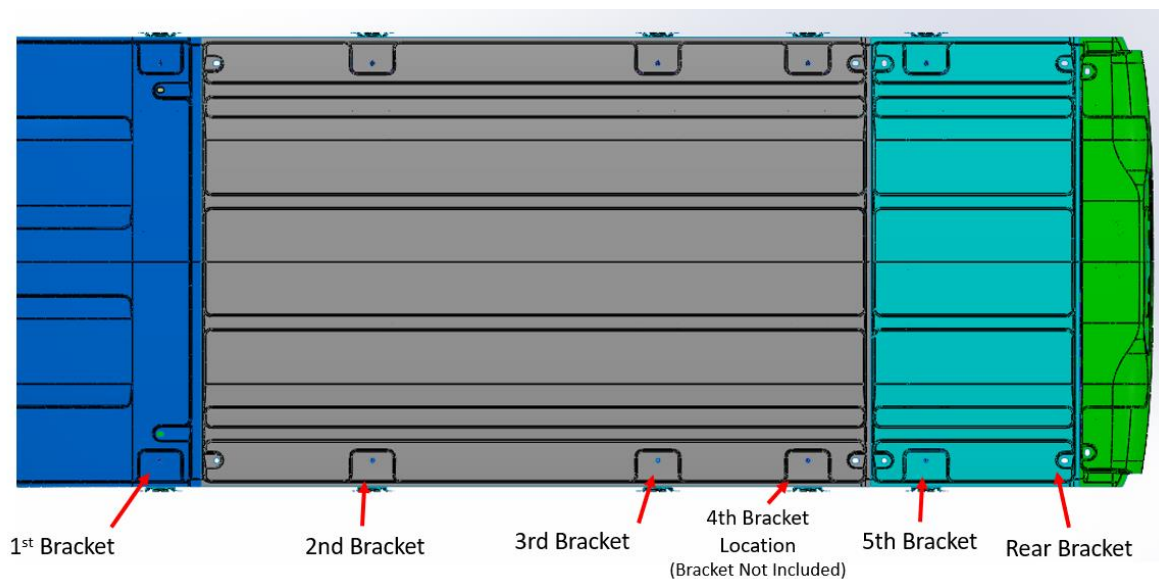

Figure 5: 148" WB Ext. Length Mounting Locations

Figure 6 shows the last four mounting positions with brackets, and the fourth mounting location being **SKIPPED** like it is with our standard transit extended length rack kits. An additional set of brackets can be purchased separately and installed at this 4th location if additional rack support is desired.

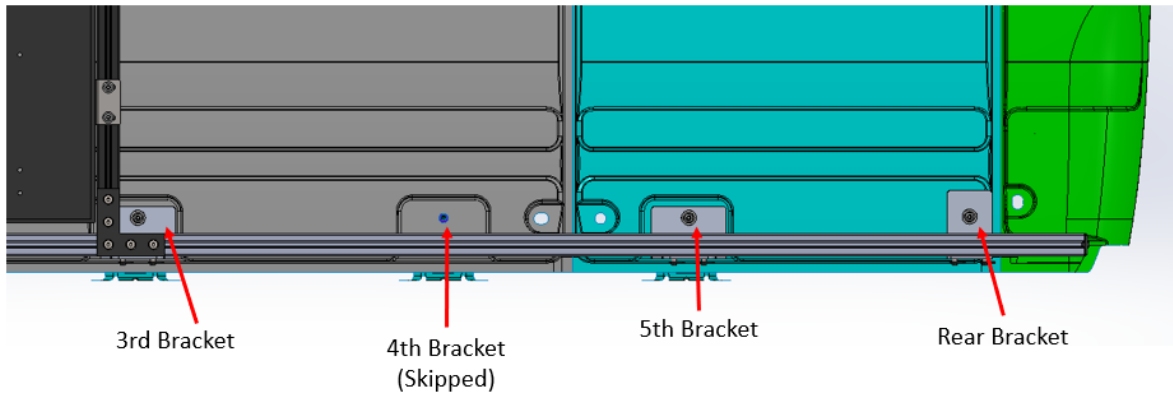

Figure 6: Detailed view showing 148 Ext Lg. back bracket locations

11. Roof Rack Bracket Installation Steps

****Important:** Read all the directions below before beginning your installation!

11.1. Transit Standard Roof Rack Bracket Installation

These instructions cover how to connect our brackets to your Ford Transit and your main rails.

1. Un-wrap your roof rack brackets and remove the hex bolts and washers.
2. Place a bracket and its hardware at each mounting point you plan to use on the van roof.
3. Carefully remove rack mounting hole covers at mounting pad locations

****Other hole covers may be present on the roof, only remove the hole covers at the rack mounting pad locations****

- a. A plastic scraper or putty knife can be used to pry up and pull off the covers over the holes
- b. Light heat can be applied to the hole cover if needed to help loosen up any adhesive

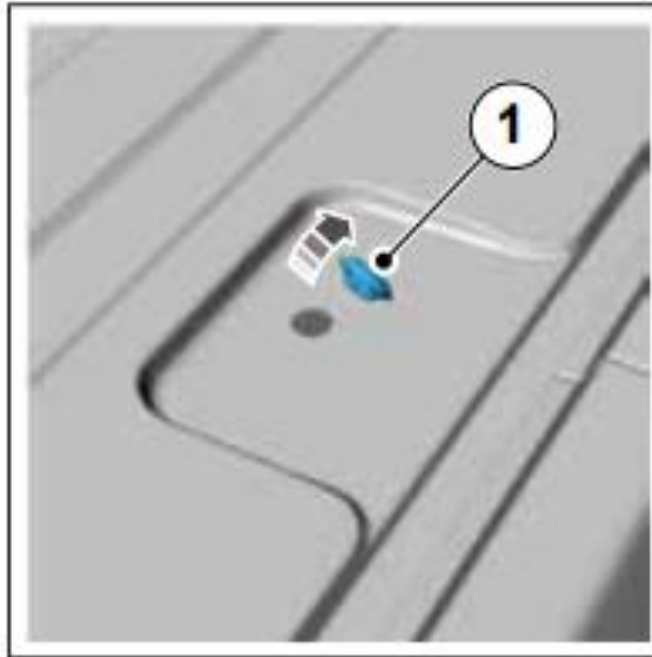

4. Enlarge any holes in the van roof as needed
 - a. This should not be required on every hole, but it is common to have to enlarge 1 to 2 mounting hole locations that were not aligned correctly at the Ford factory
 - b. If any of the bolt locations are covered up by the sheet metal of the van roof use a file, tin snips, or a small Dremel to open the hole to allow access to the bolt hole. ****Protect the rest of the van roof from metal shavings as needed****
 - c. Remove any metal shavings from the roof of the van and clean the area completely
 - d. After cutting, apply primer and paint to any bare metal after cutting is complete
5. Loosely install each rack bracket at the desired mounting locations
 - a. Center the lower slot over the bolt hole
 - b. Loosely tighten the M8 bolt using the 5mm Allen key to keep the bracket in place. Do not fully tighten at this time so that the brackets can be aligned to each other using your side rails.
 - c. **Helpful Tip:** Do NOT fully tighten this hardware yet, leave it slightly loose. Check the alignment of all brackets along the length and the spacing from one side rail to the other. As you get things in place slowly snug up a few pieces of hardware to hold it in place. If you are using 8020 cross bars you may want to hold up or temporarily bolt it in place to check the alignment. Re-check and once everything are in place and parallel go back and tighten all the hardware

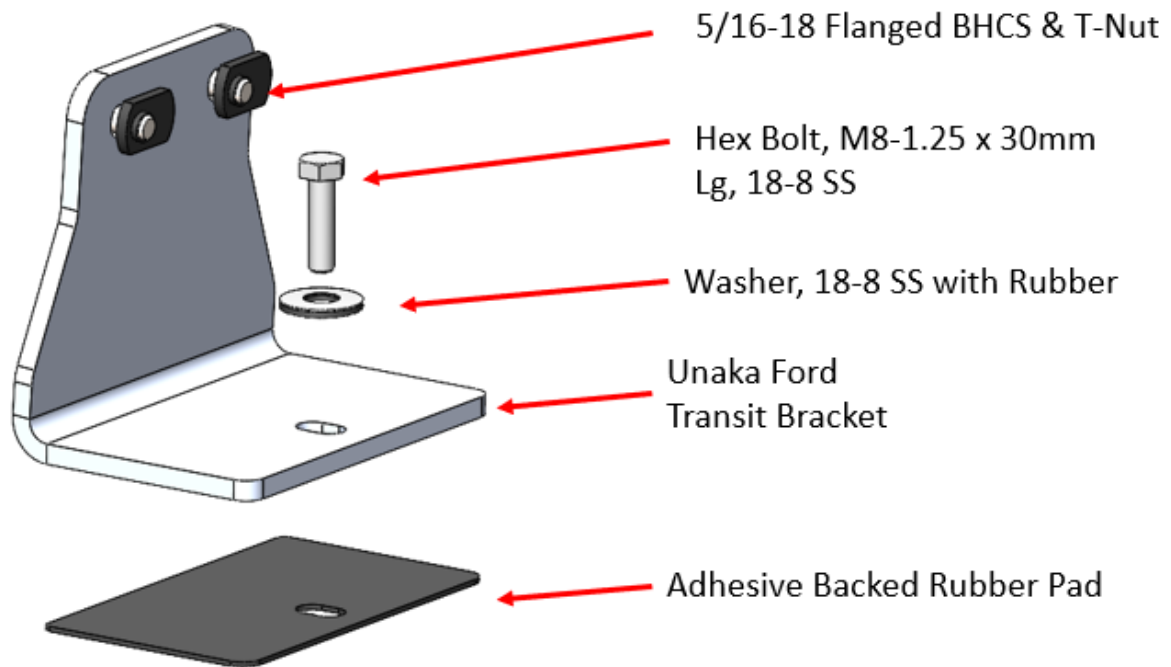

Figure 7: Transit Bracket hardware locations

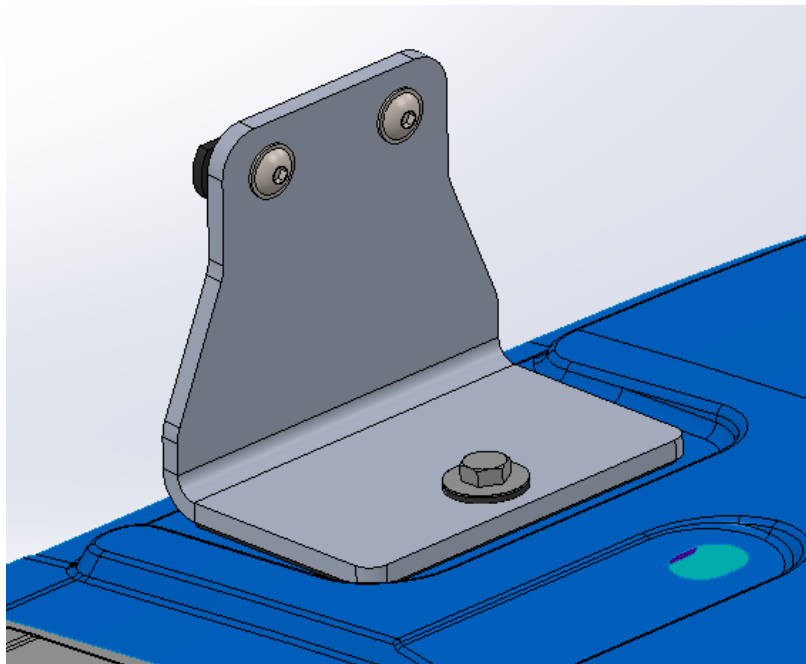
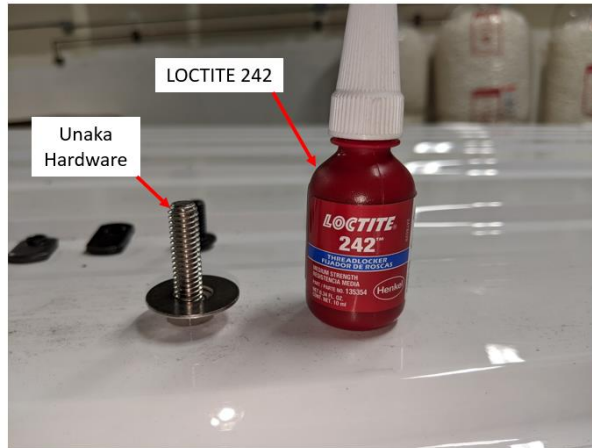

Figure 8: Transit bracket secured to van roof

6. After the initial fit up and before final installation of any hardware, apply LOCTITE 242 to the hardware per their directions.



11.2. Transit 148" Ext. Length Rear Roof Rack Bracket Installation

To better utilize more of the roof on the Ford Transits, we designed a unique bracket to help extend and support your rack side rails. The installation process of this bracket is very similar to the standard bracket with a few small differences.

1. Steps 1 through 4 are identical to those for the standard bracket
 - a. During step 4, there is no threaded insert underneath the cap area
2. Loosely install each rack bracket at the desired mounting locations
 - a. Center the lower slot over the bolt hole
 - b. Insert the M8 bolt through the sealing washer, and the rear bracket, and into the van as shown in Figure 9
 - c. From inside the van, insert the provided square or second large round washer onto the bolt, and the M8 Nyloc nut. **Apply anti seize to the end of the bolt before installing the nut.
 - d. With one person on the outside, and one person on the inside, do not fully tighten at this time so that the brackets can be aligned to each other using your side rails.
 - e. Helpful Tip: Do NOT fully tighten this hardware yet, leave it slightly loose. Check the alignment of all brackets along the length and the spacing from one side rail to the other. As you get things in place slowly snug up a few pieces of hardware to hold it in place. If you are using 8020 cross bars you may want to hold up or temporarily bolt it in place to check the alignment. Re-check and once everything are in place and parallel go back and tighten all the hardware
3. With all the bracket in place, you can proceed to the next step and install your 8020 side rails

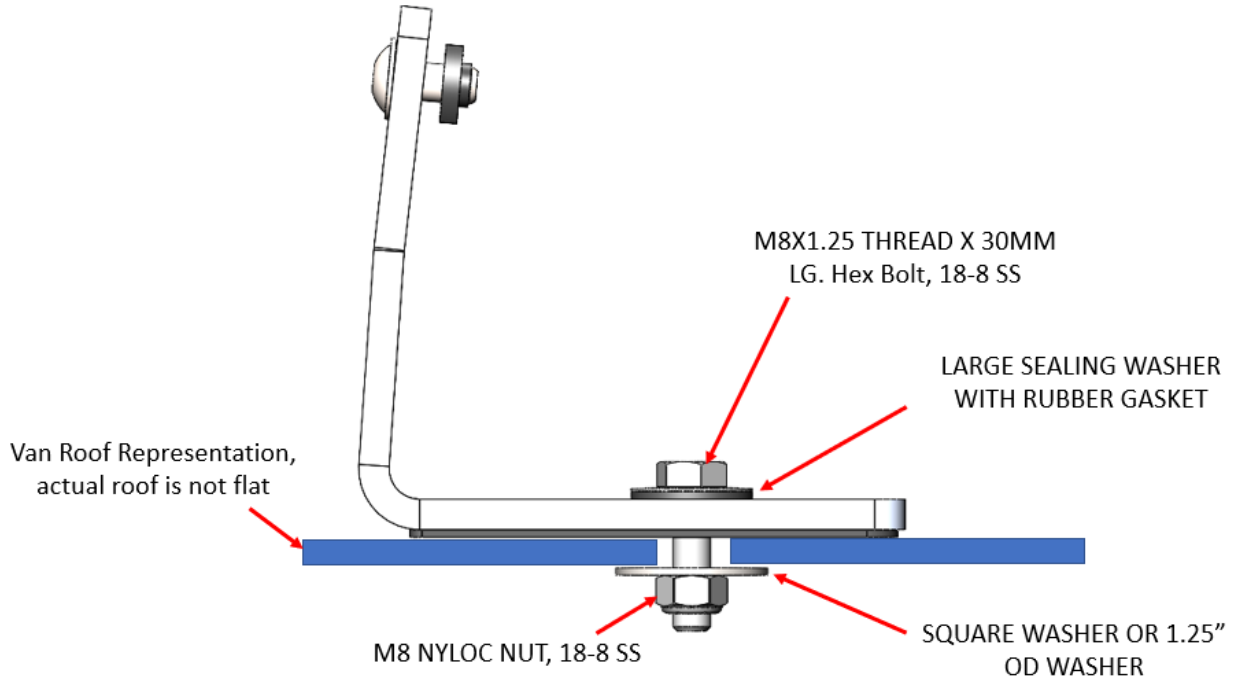

Figure 9: Transit rear bracket hardware

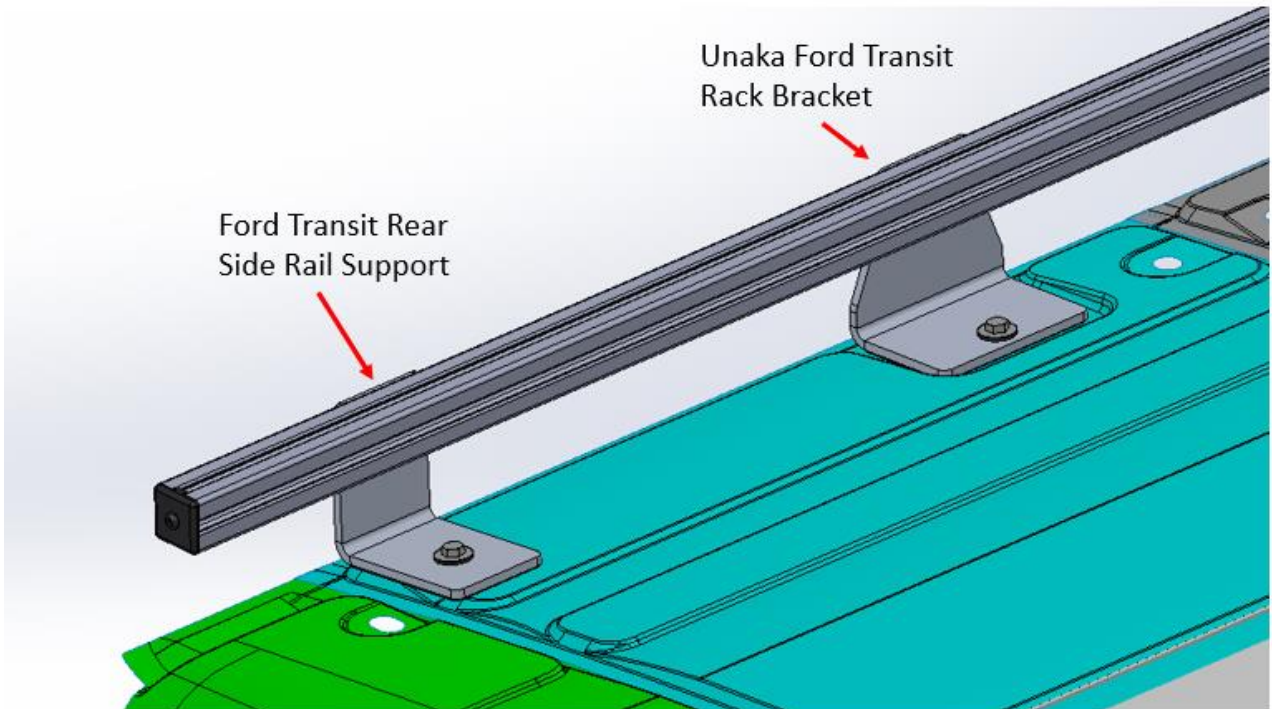

Figure 10: Standard versus rear transit bracket

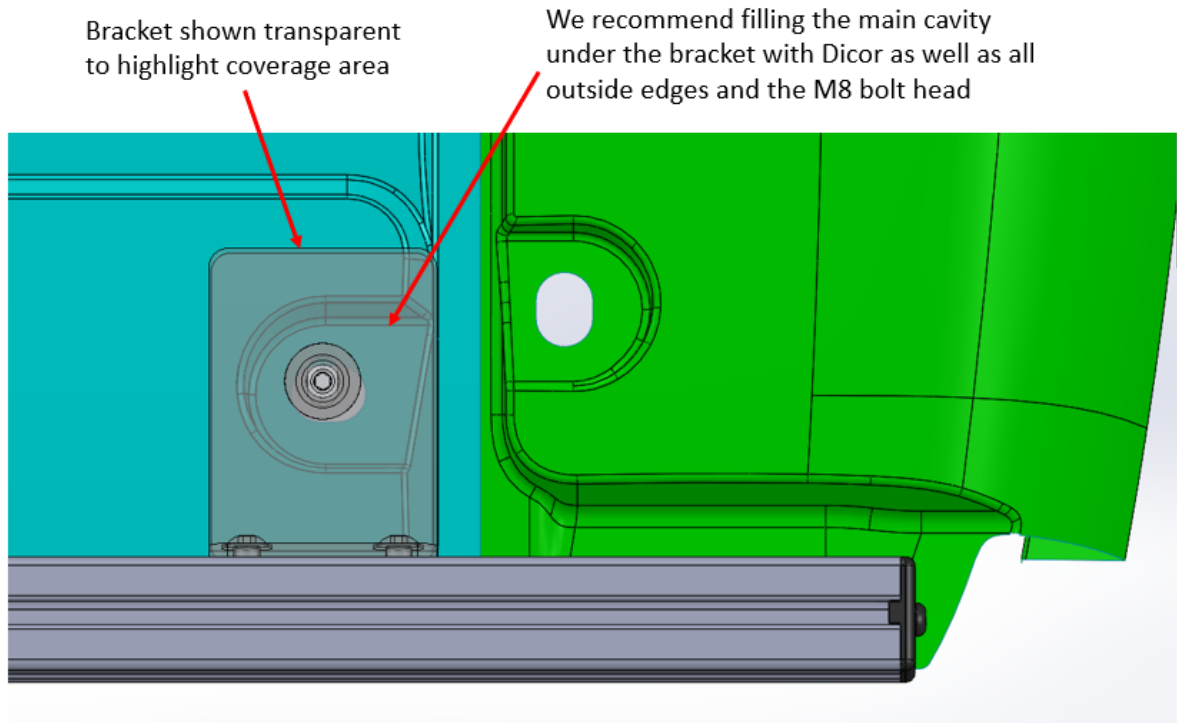

Figure 11: Transit rear bracket location

12.Side Rail Installation

The 8020 side rail assemblies can be mounted two different ways to the Unaka rack brackets which allow you to use the standard width cross bar of 56.125" long or the wide cross bar that is 59.625" long. The side rails is made up of a two piece assemblies that are joined at one of our rack brackets, and then typically stiffened up using a 4 hole splice plates which are included with each kit. Note the splice plates is 1 x 4 hole plate per side rail. Additional splice plates are typically not required, but can be purchased if needed.

12.1.1. Side Rail Mounting for 56.125" Lg. Cross Bars

The standard side rail mounting bolts the 8020 side rails to the inside of the rack brackets as shown in Figure 12. This makes a slightly narrower rack which some perceive as being stealthier. Depending on the quantity of cross bars being used, this can slightly reduce the material cost of the rack kit. The standard side rail mounting method sets your allowable space between the rails to be 56.125" which is set by our standard cross bar assemblies. This becomes your allowable space to mount your solar panels so if your panels are wider than 55.125" then you may want to consider the wide mounting method.

Side rails mounted to the inside of the rack brackets.
This configuration is for the narrow cross bars.

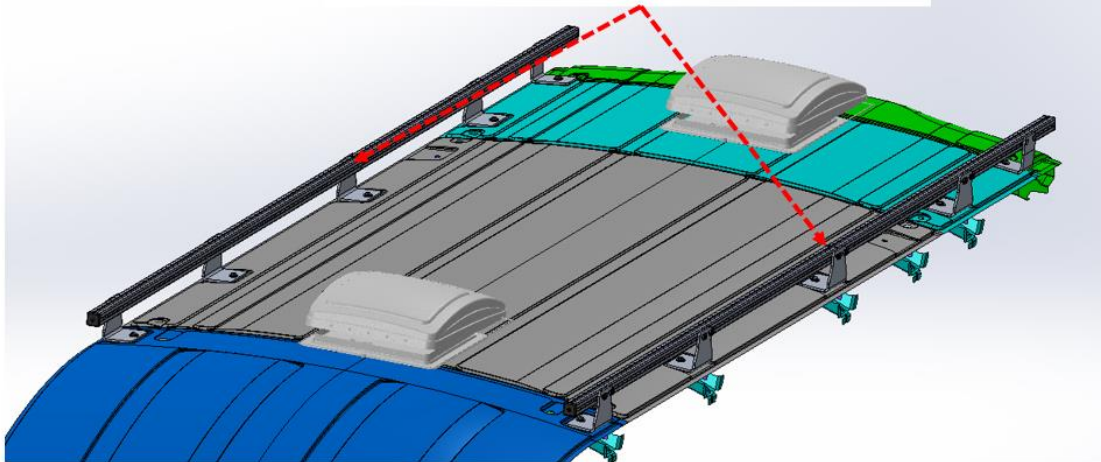

Figure 12: Standard 8020 Side Rail Mounting

Note that the amount of clearance between the splice plates if mounted to the inside of the side rails is closer to 55.125", not 56.125".

12.1.2. Side Rail Mounting for 59.625" Lg. Cross Bars

If your rack set up needs a few extra inches of rail-to-rail clearance or total width you can mount your side rails to the outside of the of the rack brackets as shown in Figure 13. Mounting your side rails on the outside of your rack brackets sets your allowable space between the rails to be 59.625" which is set by our wide cross bar assemblies. This becomes your maximum allowable space between the rails. The average useable space for your solar panels to fit is closer to 58.625" since the rack brackets now occupy some of that space between the rails at their specific locations.

Side rails mounted to the outside of the rack brackets.
This configuration is for the wide cross bars.

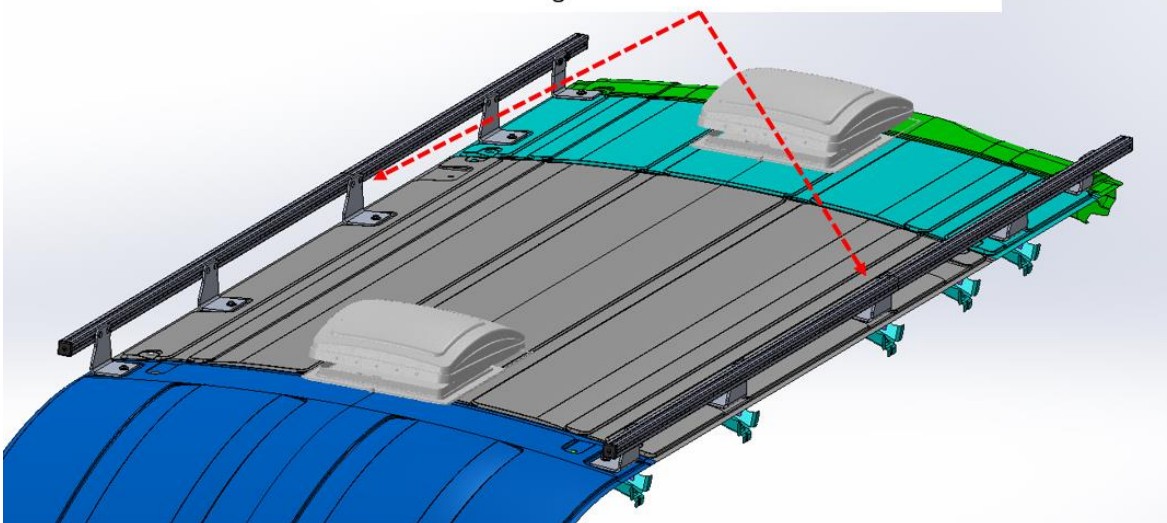

Figure 13: Wide 8020 side rail mounting

12.1.3. Side Rail Layout

1. Sit the 8020 side rails on the roof so they are towards the center of the van resting inside of the Unaka roof rack brackets which should already be in place but not tight. This will prevent any pieces from accidentally falling past the roof rack brackets and off of your van.
 - TIP: To help protect the paint job on the roof of the van, put some towels or other protective material between your roof and the 8020 material or tools resting on the roof.
2. Pick a side of the extrusion and designate it as the top of the extrusion for both the front and the rear side rails. All four sides are identical, so it does not matter but you must start somewhere.
 - Tip: You can use painters' tape to easily label the extrusion as needed to help ensure you are sliding your t-nuts into the correct slot during the later steps.
3. Determine the location and orientation of your splice plates.
 - **This step is simple but should not be overlooked. Based on your initial layout, will any other components need to share the same space as the splice plates?
 - Standard Set Up: Our standard set up is to install one splice plate on top of each side rail

Side Rail Splice Plate Options

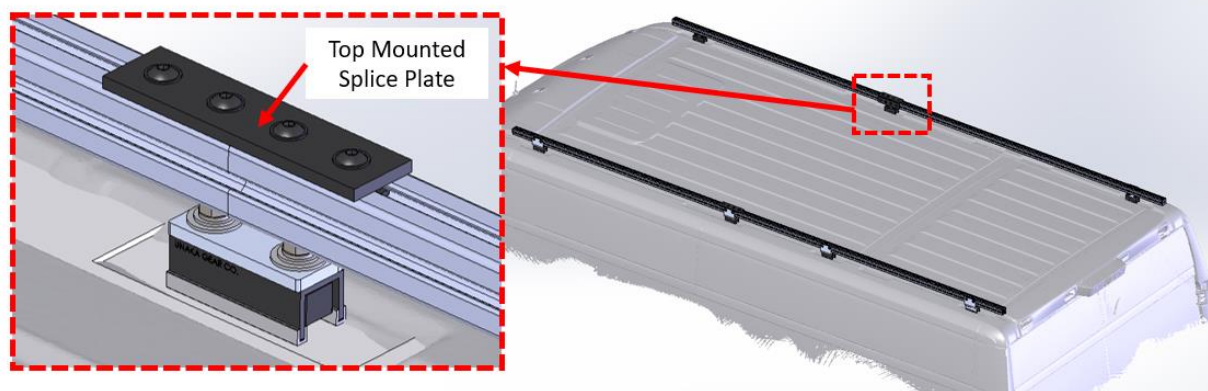

Figure 14

- Other Options: The single splice plate per side rail can also be mounted on the inside of the side rail (for narrow cross bars) or the outside of the side rail (for wide cross bars).
- If additional splice plates are ordered, then multiple splice plates can be used per side rail to further increase the stiffness of the joint as shown in Figure 15.

Side Rail Splice Plate Options

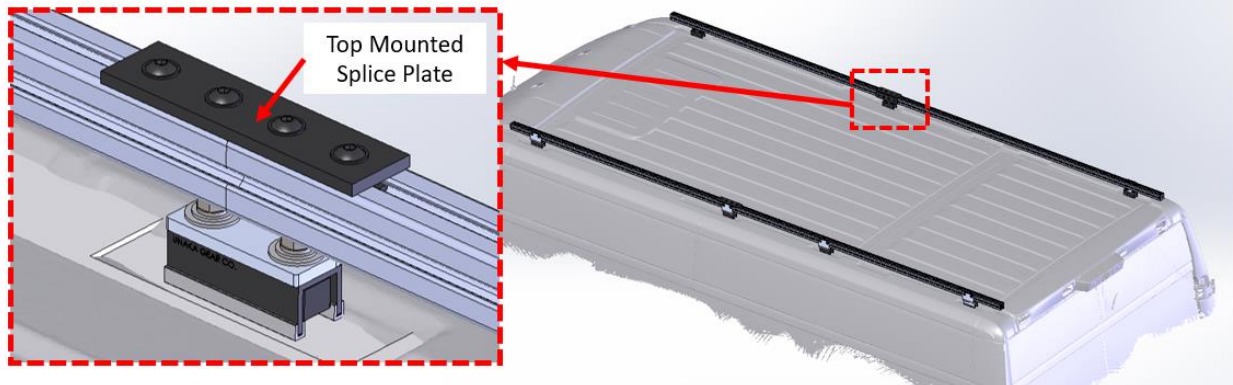
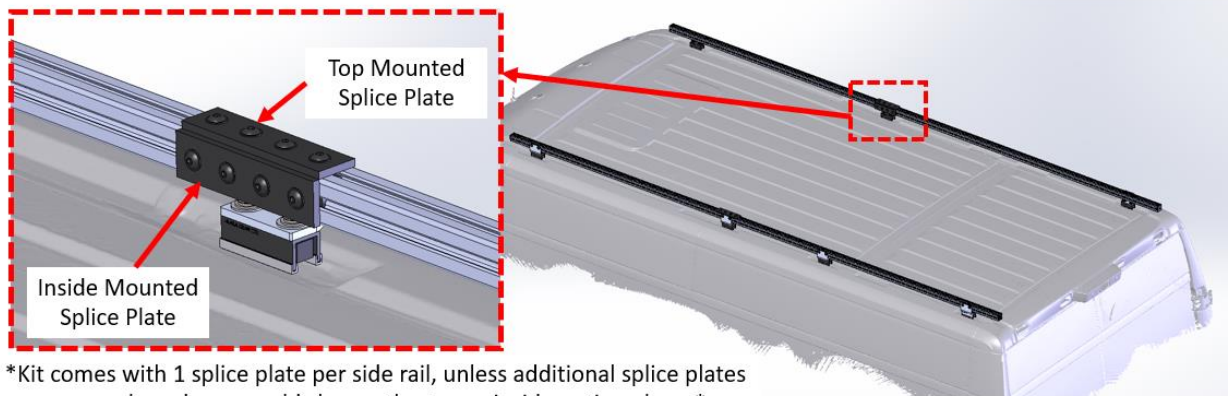

Figure 14: Typical splice plate installation with 1 plate on top of each side rail **Example image shown is of a ProMaster Van



Kit comes with 1 splice plate per side rail, unless additional splice plates are purchased you would choose the top or inside option above

Figure 15: Multiple splice plates **Example image shown is of a ProMaster Van

In some cases, your rack layout may require your cross bars to occupy the same space as the splice plates, see Figure 16. In this example, there are no fans or other items on the roof that would prevent the solar panels and cross bars from being installed a few inches further back to eliminate the interference. If this was not an option, the L-bracket can simply be rotated 180 degrees so that it is pointed away from the splice plates instead of towards them.

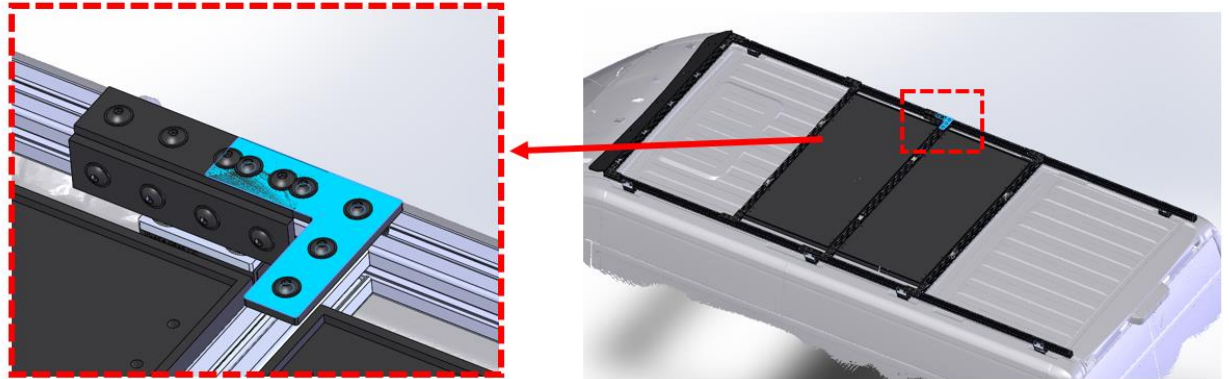

Figure 16: Top splice plate and cross bar bracket interference, flip L-bracket 180 degrees or move splice plate **Example image shown is of a ProMaster Van

If you cannot re-arrange your layout the following options can be used to eliminate the interference

- If possible, rotate the L-brackets 180 degrees so they do not interfere with the splice plates.
- If the rack is only supporting solar panels and the front and rear side rail are being joined at a rack bracket on one side, then consider just using 1 splice plate instead of both plates.

12.1.4. Install the Side Rails

If you are working alone, it is easier to install the front side rail and rear side rail separately. If you are working with a partner, you can bolt the front and rear piece together using the splice plates, and then carefully install the side rail to the rack brackets.

1. For all van sizes, roughly position your side rail assemblies so the front leading edge of the front side rail is roughly 6.25" in front of the first Unaka bracket as shown in Figure 17. This should locate the splice between the front and rear side rails at another rack bracket. At this point your 8020 side rails will still be resting on the roof and the final position will be adjusted later. Figure 18, and Figure 19 show the basic side rail assembly set ups for the Ford Transit 148" WB and 148" WB Extended vans.

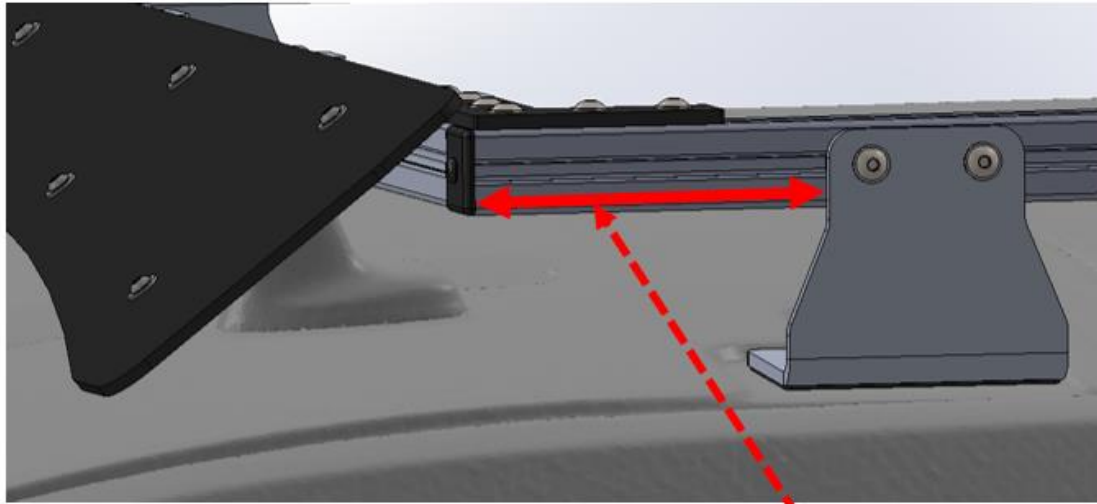

Target 6.25" as an initial starting point, adjust as needed or desired

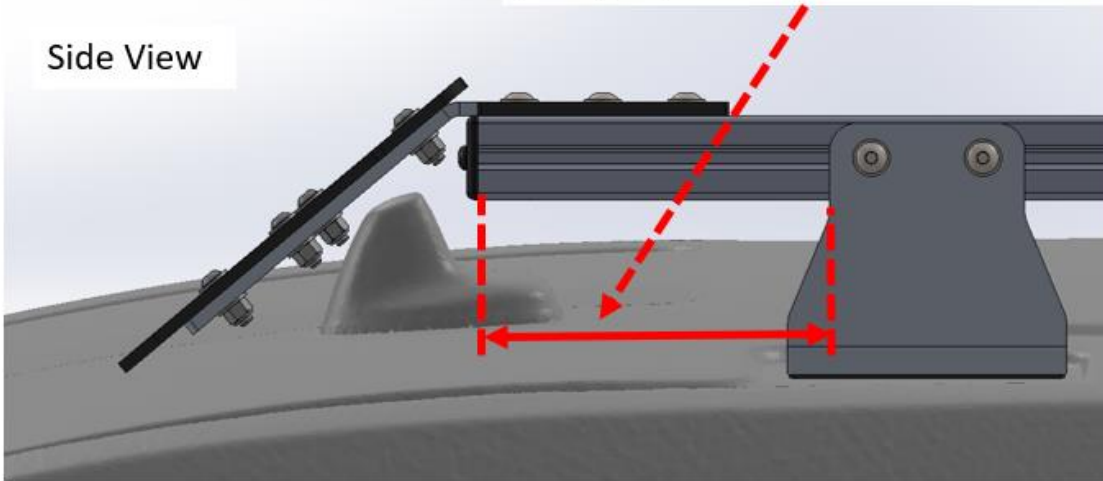
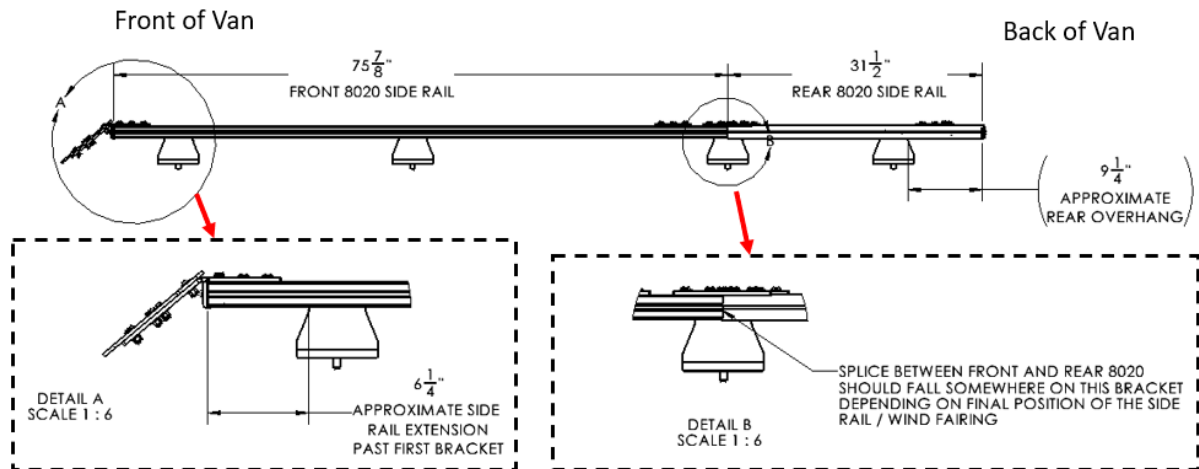
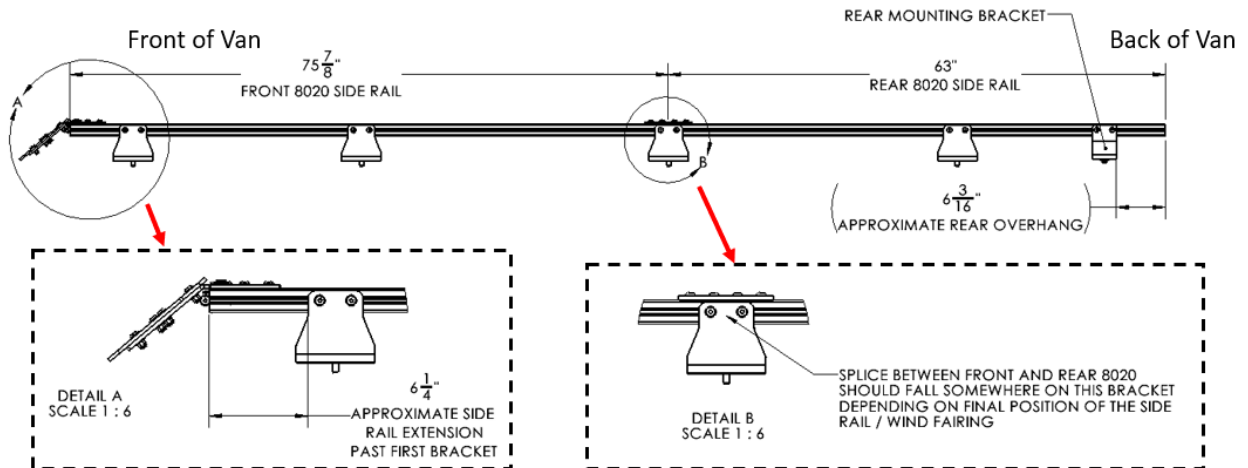

Figure 17: Approximate side rail extension from first rack bracket



Rack brackets and side rail shown in position for wide cross bars

Figure 18: Ford Transit 148" WB Side Rail Locations



Rack brackets and side rail shown in position for narrow cross bars

Figure 19: Ford Transit 148" WB Extended Side Rail Locations

Figure 19 shows the dimensions and splice locations on a Ford Transit 148" WB Extended van. The 6.25" dimension from the front rack bracket is the same for all three van sizes. The only thing that changes from one van size to the other is how many rack brackets are used, how long the side rails are, and where the splice location is located.

Note: If for some reason this splice is not over an rack bracket the assembly process can go on. The 1 splice plate provided will make a strong connection but we would recommend ordering an additional set of splice plates to further stiffen up that connection.

2. Locate the t-slot in the extrusion that is going to bolt to the rack brackets, this will either be the inside face or the outside face of the extrusion with respect to the top of the extrusion which you already labeled.
3. Slide 2 x T-nuts into the extrusion for each rack bracket you will be bolting to. Space the T-nuts so they are 2" to 3" outside of the bracket profile on each side, Figure 20. This will allow you to

slide them into place when you are ready to insert the hardware. We typically place the long end of the t-nut towards the center of the bracket. Note 8020 specifies the boss on the t-nut should be facing the middle of the extrusion as shown in Figure 21.

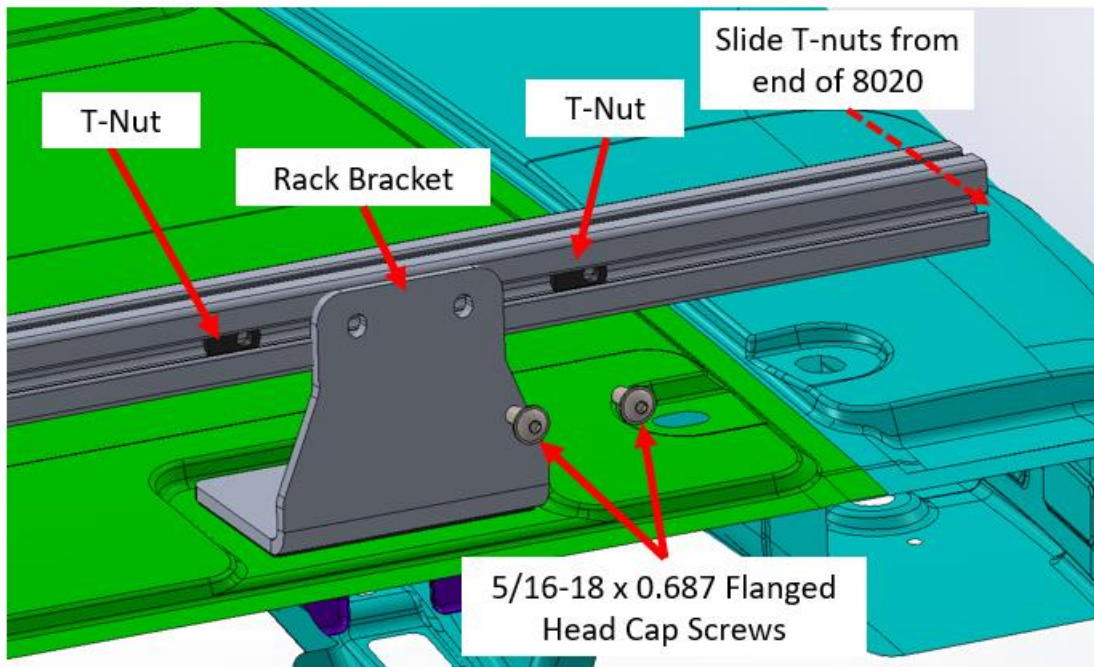

Figure 20: Unaka rack bracket hardware installation

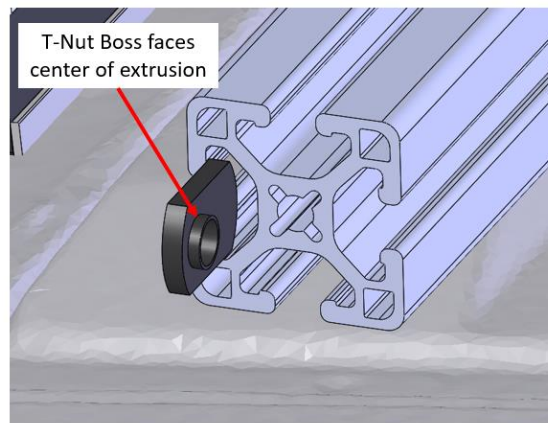

Figure 21: 8020 T-Nut Installation

4. Once all the hardware for one side rail is in place and spaced on both sides of the rack brackets, the rail can be bolted to the bracket. Start at one front of the van. Place the 8020 against the rack bracket, slide one of the 2 nuts so that it lines up with the hole in the rack bracket, then insert the Flanged Button Head Cap Screw and tighten it using a 3/16" Allen Key. Do not fully tighten, leave this loose.
5. Go to the back of the van (rear most mounting bracket) and repeat the previous step of aligning the nut, and loosely inserting the bolt.

6. Repeat these steps for the other side of the van.
7. Adjust the position of your side rail assemblies. This is best done with both side rails loosely in place and only being supported by a few pieces of hardware so that they are easier to move forward or backwards. Slide the side rail forward or backward as needed to achieve the 6.25" dimension shown in Figure 22 or is adjusted as desired. This 6.25" dimension is a recommendation. This is a good time to hold up the wind fairing and a cross bar assembly to make sure the location does not interfere with any parts of the van and matches the van profile as desired. Wherever the side rail assemblies end up use a tape measure to ensure that they are equal distances from the front rack bracket on both sides of the van.

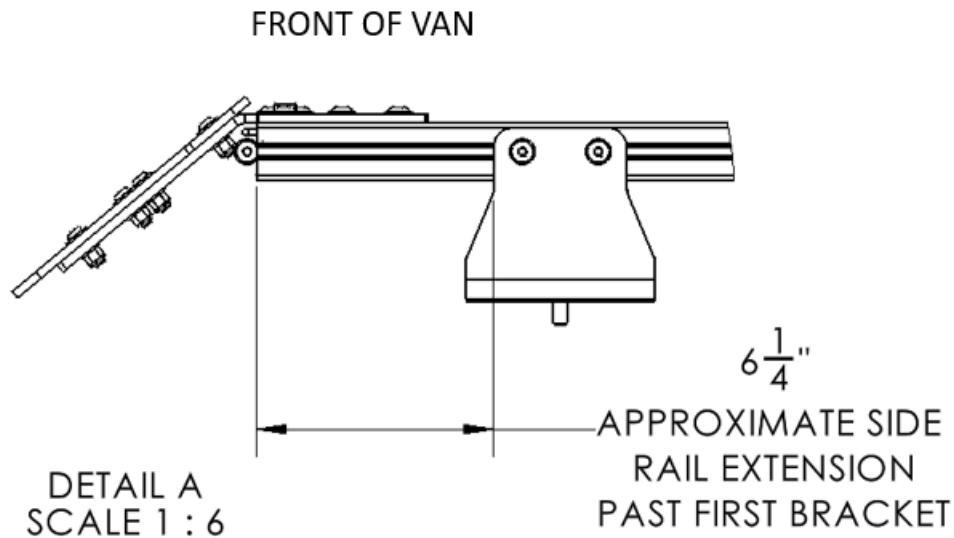

Figure 22: Front side rail location

8. Loosely secure the remaining rack brackets to your 8020 side rails as done in Step 4 above. Leave all bolts loose until you get all the bolts in place on both side rails.
9. Do not fully tighten any of the hardware at this point.

12.2. Loosely Assemble Cross Bar Assemblies

If you haven't done so, double check to see if any other parts in future steps will need to be attached to your cross bars and how many t-nuts will be required for each item. This includes flush mount solar panel brackets, other 8020 brackets, the wind fairing, etc. The steps for loosely assembling your cross bar assembly are outlined below and shown in Figure 23.

Optional Step: You may choose to label one or two sides of your cross bar assemblies to help keep track of which slot is which when it comes time to pre-insert hardware into these slots.

1. Slide the required number of t-nuts for any items that will need to be secured at later steps into the extrusion in the respective slots. Most commonly the only slot that requires additional hardware is the top slot.

TIP: You can always put a small tape ball in the slot to keep the t-nuts from sliding out of the ends of the extrusion when you go to move them from your layout location to your van roof.

2. Slide the required number of t-nuts for the mounting brackets into the respective t-slot.
3. Install the brackets required to secure your cross bar to the side rails. The Unaka standard option is the flat 5 hole L-brackets which each use 5 bolts and t-nuts. Other options include using cross bars that use 4 x 2 hole corner brackets or your own custom solution.
4. Do not fully tighten the hardware at this time. Leave at least one or two pieces of hardware tight enough where the brackets won't come loose and slide off the end of the extrusion while lifting and lower the cross bars into place.
5. **DO NOT INSTALL SOLAR PANLES until all main rack hardware is tight, and transit pads have been sealed with Dicor or similar**

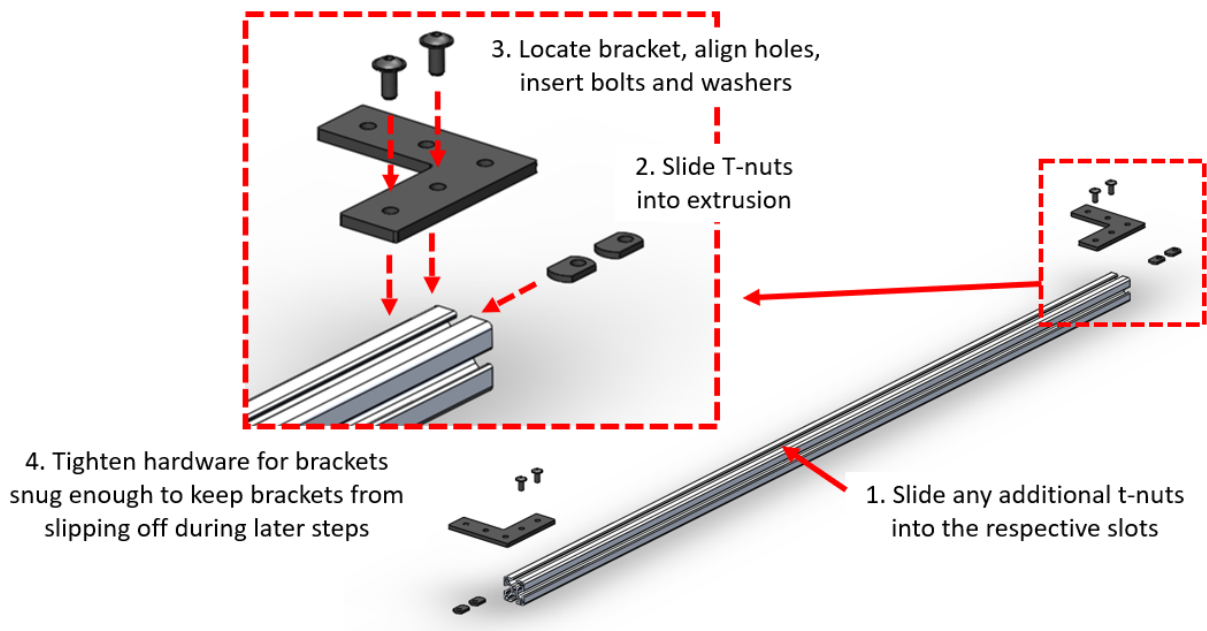

Figure 23: Initial cross bar assembly

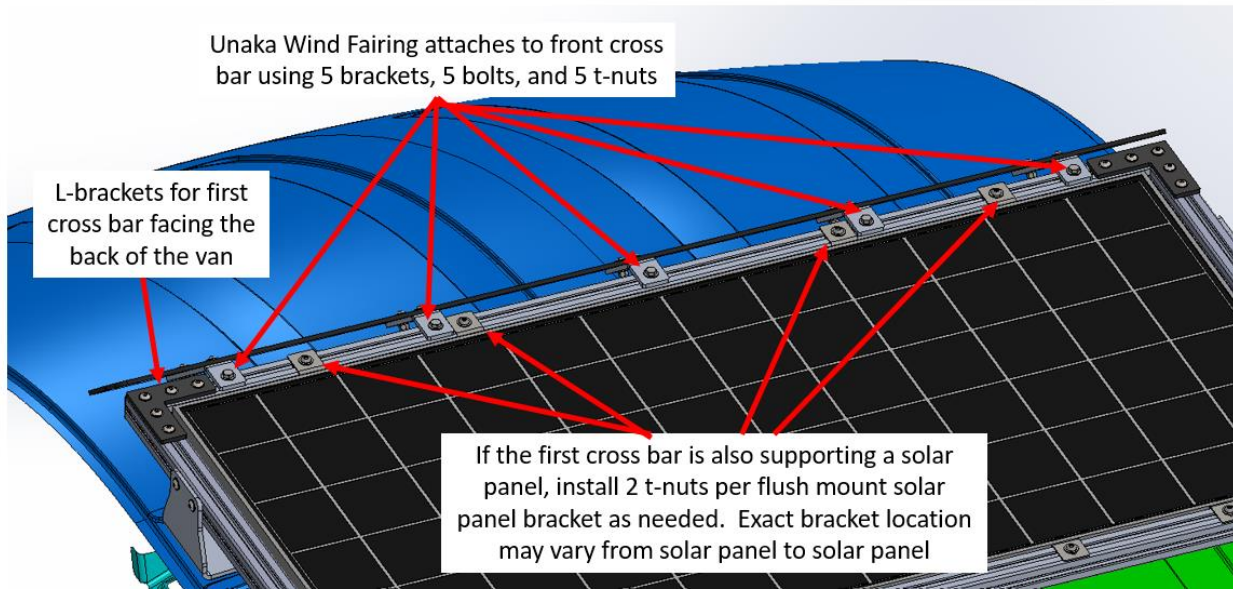

Figure 24: Front cross bar possible required hardware

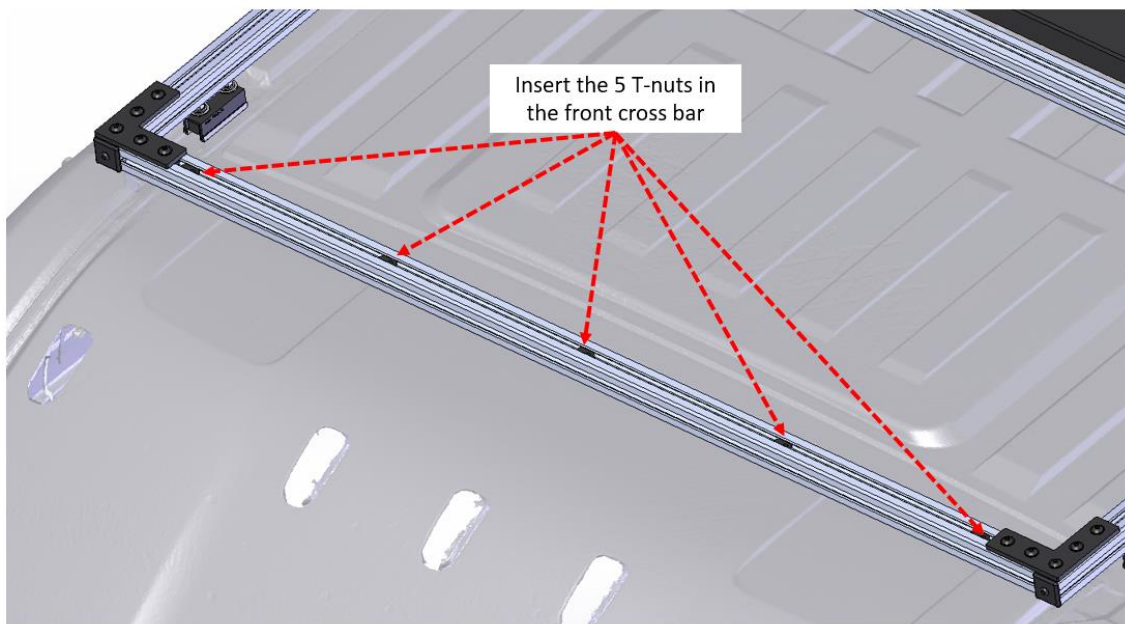

Figure 25: Add the 5 wind fairing t-nuts before assembling front cross bar ****Note image is from a ProMaster Rack****

12.3. Use 8020 Cross Bar Assemblies to Position and Tighten 8020 Side Rail Assemblies

This step is to help ensure that the 8020 side rail assemblies are installed parallel (even spacing) from the front of the rack to the back of the rack. If you do not plan on installing cross bar assemblies, you can use a tape measure to help set the spacing so that it is even from one rail to the next.

CAUTION: If this step is not followed and the side rail assemblies are installed too closely together then parts of the rack will need to be loosened to complete later assembly steps.

1. Quickly check the crossbar lengths to ensure they are all roughly the same size, if one is slightly longer due to the cutting process use this cross bar as the first cross bar at the front of the van.
2. Space your cross bars along the length of your side rails from the front of the van to the back of the van.

Note: If you only have one cross bar, you will have to move the single cross bar along the length of the rack multiple times as you check the spacing and start tightening the side rail assemblies.

Loosely sit cross bars along the length to ensure side rails are correctly and evenly spaced from the front to back

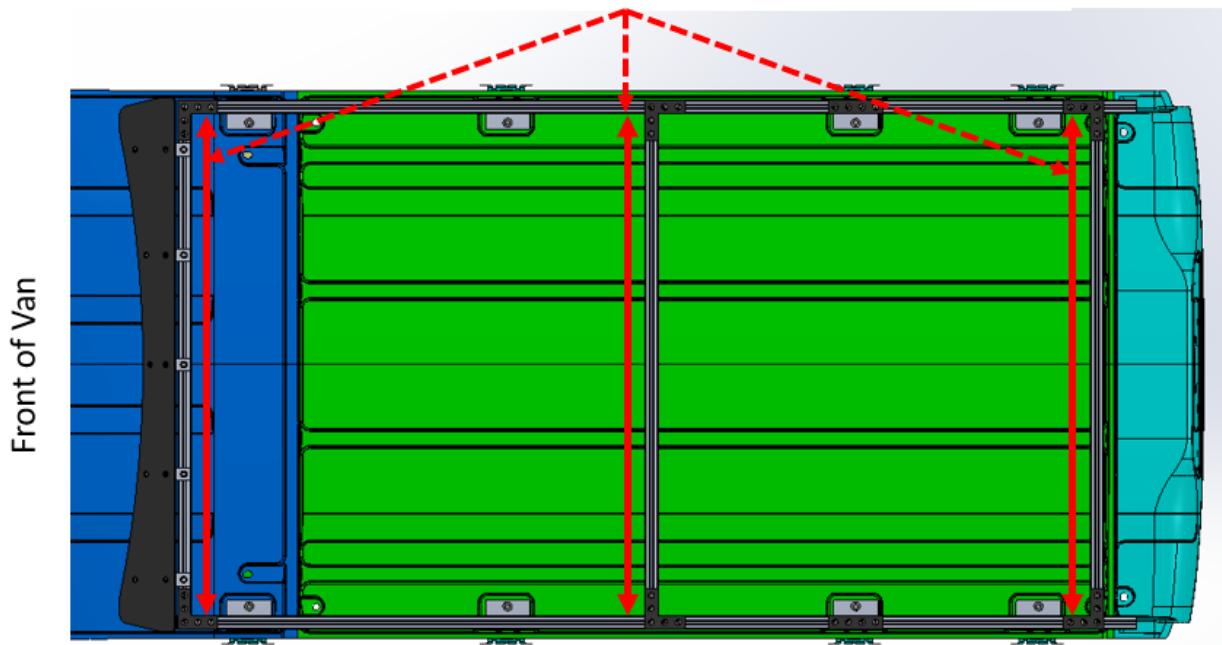
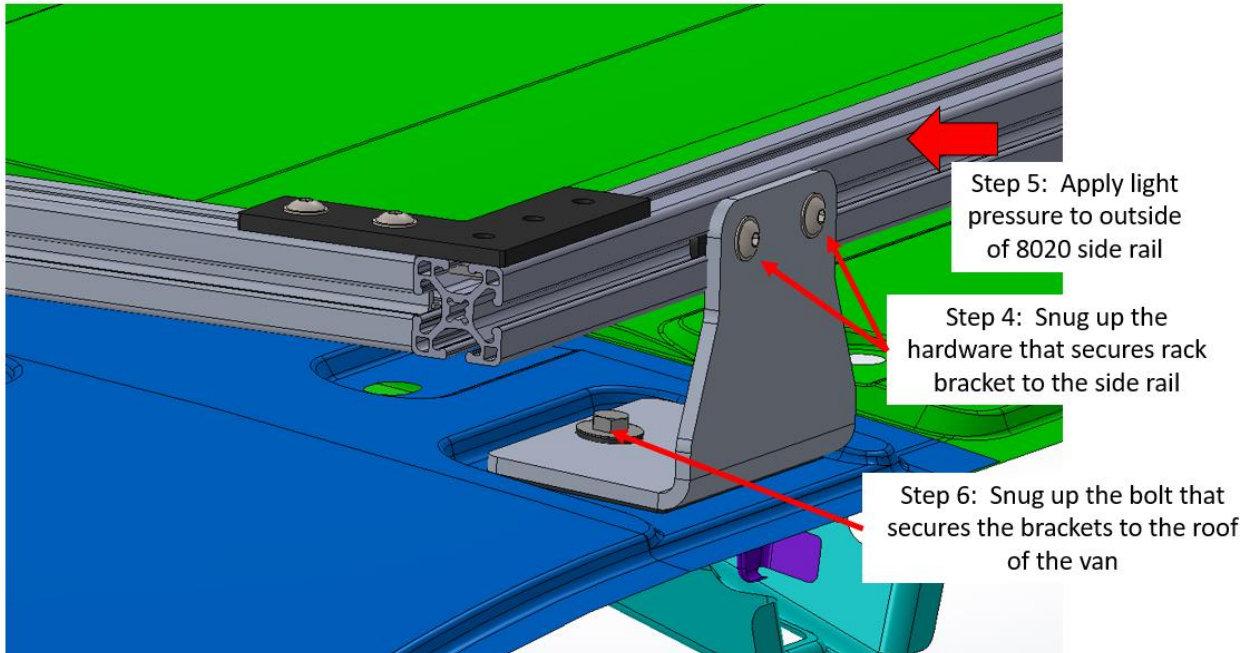

Figure 26: Use cross bars to align side rail assemblies

3. Since the hardware on the side rails is still loose, go to the front Unaka Rack Bracket assembly and check the spacing of the side rails with respect to the bracket and wind fairing installation. Make sure the side rail position matches your final desired dimension as discussed Figure 22. Note Unaka called out 6.25" but you may have decided to use a different dimension here for a more ideal wind fairing fit.
4. Snug up the hardware that secures the rack bracket to the 8020 side rail
5. At the front most bracket, apply slight pressure to the outside of the side rail reducing any gap that may exist between the inside of the side rail and the cross bar.
6. Snug up the hardware that secures the rack bracket to the roof of the van.



7. Repeat steps 4 – steps 6 along the length of the van until you have snugged up all the roof rack brackets.
8. Note that you may choose to move the cross bars you are using to maintain the rail to rail spacing up and down the rack as you complete these steps to further ensure that the rails are parallel, and your cross bars can be adjusted or installed as needed.
9. Repeat steps 3 – steps 8 on the opposite side of the van.

12.4. Install 8020 Cross Bar Assemblies

Since each van installation varies due to ceiling fan placements, fan / vent quantities and locations, AC units, sky lights, and the quantity / size of solar panels slight variations in this process may vary based on your individual needs. Don't hesitate to reach out to contact us, we are here to help.

1. Roughly place all cross bars on the van roof or rack close to their final installation locations
2. Slide all the required t-nuts into the side rails to secure your cross bars. Leave the t-nuts off to the side of each bracket in small groups for each cross bar as needed so that they can be slide into their final location during later steps.
 - a. For the Unaka flat 5 hole L-brackets, 3 t-nuts are required in each side rail for each bracket
 - b. If your side rail splices plates are in place, some of the t-nuts for your cross bars may need to be installed from the open slot of the front side rail, and some from the open slot in the rear side rail.
 - c. If you plan on installing awning brackets, now would be the time to slide in the required hardware into your extrusion. If you plan on adding an awning later additional hardware can be added or drop in t-nuts can be used to prevent the need of disassembly the rack to add more hardware.

3. To ensure the best form fit of the Unaka Wind Fairing to the van roof we recommend starting with your cross bar placements at the front of the van and working backwards. Install cross bar #1 at the front of the van.

12.4.1. Install Front Cross Bar

Notes:

- Once the front cross bar is installed it will prevent additional t-nuts from being installed in the top side rails slots from the front of the van
 - Make sure all the required hardware to secure the wind fairing, flush mount solar panel brackets, or other items are in their correct slots before installing this cross bar.
1. The front of the first cross bar should be installed so that it is flush or near flush with the front of the side rail extrusion.
 2. The front cross bar can be installed slightly behind the front of the extrusion up until the point where the wind fairing may interfere with the ends of the side rail assembly.
 3. The forward most cross bar typically supports the wind fairing assuming it was purchased as an option with the rack kit. Make sure all required hardware is in place before this cross bar is installed.

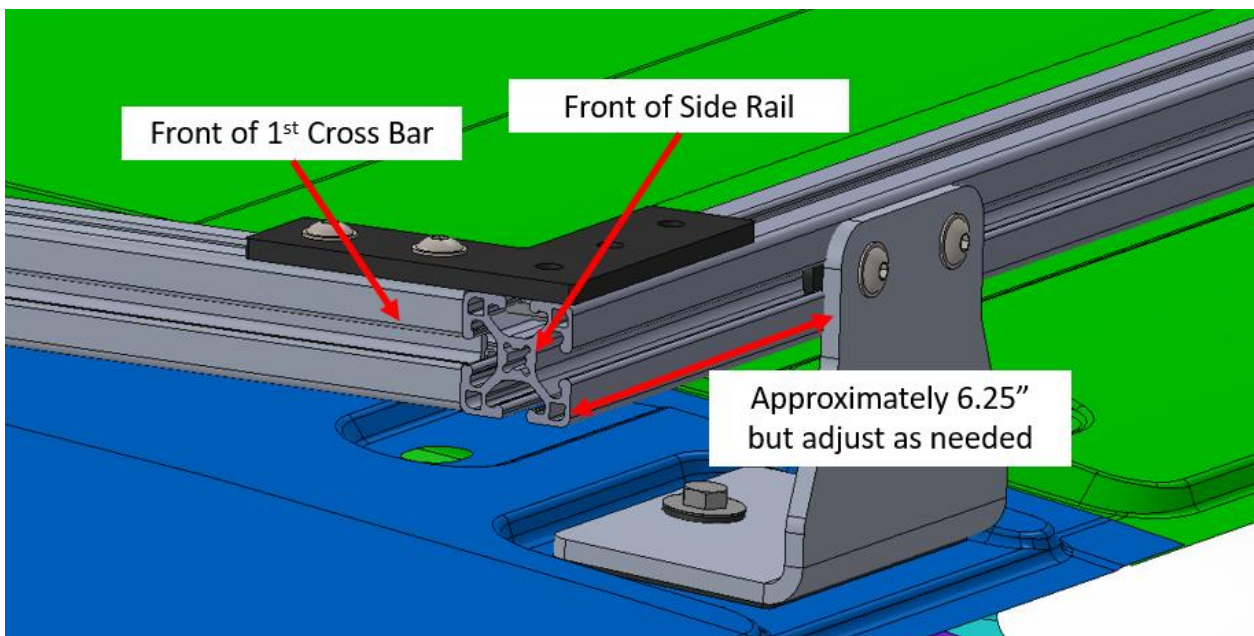

Figure 27: Front cross bar installation location

12.4.2. Install Additional Cross Bars

Install the remaining cross bars as needed. If any mid rails are used to support any solar panels, use the mid rail length to determine the next location of the next cross bar as needed.

12.5. Tighten Remaining Hardware & Seal Brackets

With all cross bars in place, go through, apply Loctite to each bolt, and tighten each piece of hardware to secure the location of the cross bar and any accessories in place.

12.5.1. Unaka Ford Roof Rack Brackets:

The M8 hex bolts that secure the rack brackets to the roof of the van should be torqued to 168 in-lbs. or 14 ft-lbs.

12.5.2. Seal Unaka Ford Roof Rack Brackets:

Each rack bracket already has a rubber gasket on the bottom, and the bolt secures the bracket to the van using a sealing washer which should keep most water out. That being said, we always Dicor the rack brackets to ensure no water can get into your van and we recommend that you do the same

Tip: For a clean Dicor installation, apply painters' tape on all 4 sides of the rack bracket

Tip: A piece of clear vinyl tubing and small hose clamp are used to Dicor the back of the bracket under the side rail assembly

Which Dicor: We typically use self leveling Dicor, but since the van roof is at an angle, some people may choose to use Non-Self Leveling Dicor.

1. Per the manufacture's directions, apply Dicor to all 4 sides of the rack bracket and the hex bolt and sealing washer
2. When ready, remove the painters tape
3. Once Dicor is dry, remove the temporary cross bars

Before Dicor



After Dicor



12.5.3. 8020 Rack Kit Hardware:

All of the remaining 8020 hardware should be torqued to 13 ft-lbs. (156 in-lbs.) using a torque wrench that is compatible with a 3/16" Allen key.

12.6. Preventative Maintenance Checks

Even though we do not expect any of the hardware to come loose, we recommend checking your roof rack hardware from time to time to help minimize the chance of something coming loose over time. Using the appropriate wrenches check the roof rack hardware to ensure nothing is coming loose at the intervals below.

- Initial check after 4 to 7 days of moderate driving
- Follow Up Check 1 month after moderate driving
- Routine checks 3 to 4 months of moderate driving
- Anytime after moderate driving on bumpy gravel roads

This completes the installation of your 8020 rack kit.

Legal Disclaimer:

Unaka Gear Co. makes no warranties whatsoever, expressed, or implied, oral, or written to any purchasers, except the limited warranty described on our website. Unaka Gear Co. is hereby specifically excluded from any implied warranty of incidental, secondary, or consequential damages of any kind whatsoever. All purchasers and users of products manufactured by Unaka Gear Co. agree to hold harmless and indemnify Unaka Gear Co from any and all claims arising from their use. Failure to receive notice of any limitations or the limitations contained in this disclaimer shall not serve to extend liability to Unaka Gear Co. for any claims arising out of use of its products.

