

HSLD Rack Installation Manual:

Sprinter 170" WB

SKU: 1006-MK51-00 REV 2

Date: 2/16/24

Revision: 2

Sprinter Roof Rails

You must have factory roof rails installed on your Sprinter before installing a Unaka Roof Rack. These can be OEM roof rails from the factory, Van Tech after market rails, or other brands. This type of rail system is required by Mercedes to ensure you maintain your factory warranty while installing a roof rack.

Tested Sprinter Rail Systems

- OEM Rails from the factory
- Vantech after market rails

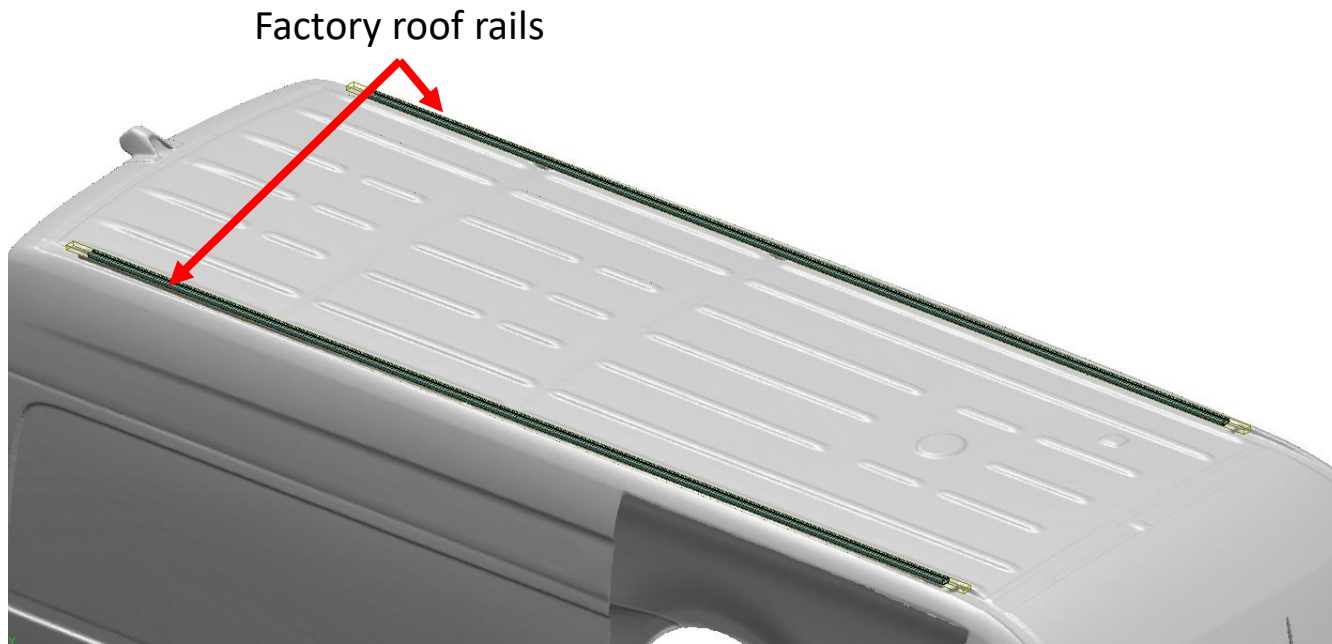

Unaka Roof Rail Washer Plate:
3-1/8" Long x 7/8" Wide x
1/16" Thick

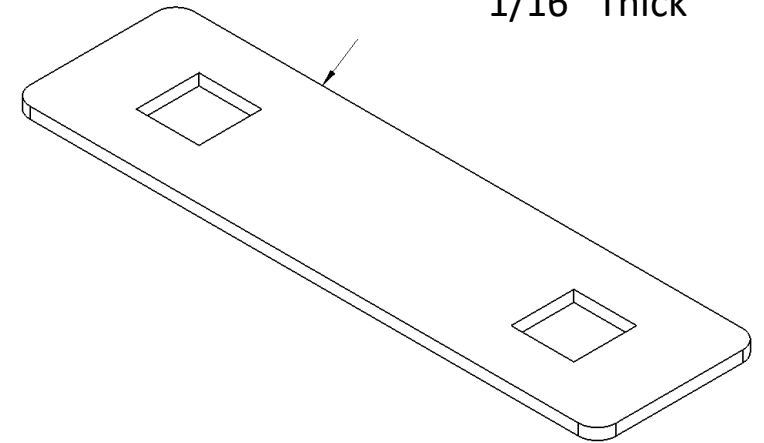

In rare cases, the Unaka Sprinter adapter bracket washer plates may not fit in to an aftermarket roof rail. The dimensions below can be used to check before you begin assembly, or you can always reach out to us with questions.

Kitting & Packaging Notes

As of February 2024, we are in the process of updating our kitting processes to make assembly and installation a touch easier. Note, all of the parts and quantities that you receive will be the same from the old method to the new method, but the hardware bags or presentation may be slightly different depending on when you get your kit.

The specific images shown in this manual are specific to Revision 2 style kits. Revision 1 is shown below for reference.

Revision 1 Style Hardware Kits

ITEM NO.	Manufacturer	PART NUMBER	DESCRIPTION	MATERIAL	QTY.
1	Loctite	1821A11	Antiseize, lb8008, Electrically Conductive, 0.2 oz. Pack	NA	1
2	Loctite	91458A111	Threadlocker, Loctite® 242, 0.02 FL. oz Capsule	NA	3
3	Unaka Gear Co.	1005-MB01-01	STRAIGHT FLAT PLATE, 15 SERIES, 4 HOLE	6061 Alloy	2
4	Unaka Gear Co.	1005-MK03-00-HW REV 0	CROSS BAR HARDWARE KIT FOR 4 HOLE NARROW PLATES	ASSEMBLY	4
5	Unaka Gear Co.	1006-MB50-06 REV 0	SPRINTER HSLD SIDE RAIL SPLICE PLATE	5052-H32	4
6	UNAKA GEAR CO.	1006-MK10-00 REV A	Sprinter Rack 8020 Adapter Bracket & Hardware - Set of 2	ASSEMBLY	5
7	Unaka Gear Co.	1006-MK51-00-HW1 REV 1	SPRINTER 170 HSLD SIDE RAIL HARDWARE KIT	ASSEMBLY	2
8	Unaka Gear Co.	1001-MK17-01 REV 1	TOP MOUNT SOLAR PANEL BRACKET, SET OF 4 W/8020 HARDWARE	ASSEMBLY	4

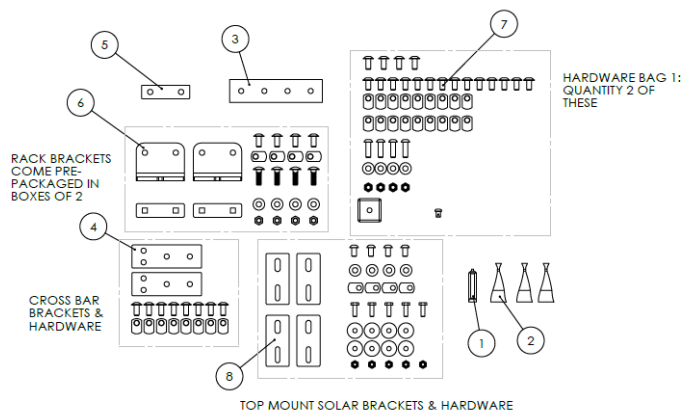

NOTES:
 1. SEE BILL OF MATERIAL FOR TOTAL KITTING QUANTITIES AS IMAGES OF EVERY INDIVIDUAL ITEM MAY NOT BE SHOWN
 2. IMAGES ARE SHOWN FOR PART IDENTIFICATION AND DO NOT REFLECT FULL QUANTITIES OF EACH PARTS, SEE SUB ASSEMBLY DRAWINGS AND BOMS FOR EXACT QUANTITIES

PACKAGING NOTES
 1. ALL ITEMS SHOULD BE PACKAGED CAREFULLY IN A SINGLE BOX.
 2. ALL ITEMS SHOULD BE PACKAGED IN A WAY THAT WILL PREVENT DAMAGE OR MOVEMENT DURING SHIPPING
 3. BOX SHOULD BE LABELED WITH SKU AND DESCRIPTION

REVISIONS				
ZONE	REV.	DESCRIPTION	DATE	APPROVED
	0	BUMPED REVISION FOR RELEASE	5/30/2023	JEO
	1	UPDATED REVISION FOR OFFICIAL PRODUCTION	6/28/2023	JEO

POST PROCESSING:
 FINISH: None

UNLESS OTHERWISE SPECIFIED DIMENSIONS ARE IN INCHES
 TOLERANCES:
 ANGULAR: ±0.5°
 ONE PLACE DECIMAL: ±0.1
 TWO PLACE DECIMAL: ±0.01
 THREE PLACE DECIMAL: ±0.005

DO NOT SCALE DRAWING

SECRETARY AND CONFIDENTIAL THE INFORMATION CONTAINED ON THIS DRAWING IS THE SOLE PROPERTY OF UNAKA GEAR CO. ANY REPRODUCTION OR USE OF THIS DRAWING WITHOUT THE WRITTEN PERMISSION OF UNAKA GEAR CO. IS STRICTLY PROHIBITED.

UNAKA GEAR CO.

TITLE: SPRINTER 170 HSLD HARDWARE BOX

SIZE DWG. NO. REV
 B 1006-MK51-00-HWB REV 1 1

SCALE: NTS SHEET 1 OF 1

Revision 2 Style Hardware Kits

ITEM NO.	Manufacturer	PART NUMBER	DESCRIPTION	MATERIAL	QTY.
1	Loctite	1821A11	Antiseize, lb8008, Electrically Conductive, 0.2 oz. Pack	NA	1
2	Loctite	91458A111	Threadlocker, Loctite® 242, 0.02 FL. oz Capsule	NA	3
3	Unaka Gear Co.	1005-MK03-00-HW REV 1	CROSS BAR HARDWARE KIT FOR 4 HOLE NARROW PLATES	ASSEMBLY	4
4	UNAKA GEAR CO.	1006-MK10-00 REV 1	Sprinter Rack 8020 Adapter Bracket & Hardware - Set of 2	ASSEMBLY	5
5	Unaka Gear Co.	1006-MK52-00-HW1 REV 2	SPRINTER 170 & 170 EXTENDED HSLD SIDE RAIL HARDWARE KIT	ASSEMBLY	2
6	Unaka Gear Co.	1001-MK17-01 REV 4	TOP MOUNT SOLAR PANEL BRACKET, SET OF 4 W/8020 HARDWARE	ASSEMBLY	4
7	Unaka Gear Co.	1005-MK01-00 REV 0	Splice Plate Kit, Set of 2 x 4 Hole Flat Plates with Hardware	ASSEMBLY	1
8	Unaka Gear Co.	1005-MK07-00-HW REV 0	HSLD SIDE RAIL SPLICE PLATE HARDWARE KIT, SET OF 2	ASSEMBLY	2
9	Unaka Gear Co.	1005-MK08-00 REV 0	8020 STYLE 15 SERIES END CAPS, SET OF 2	ASSEMBLY	1

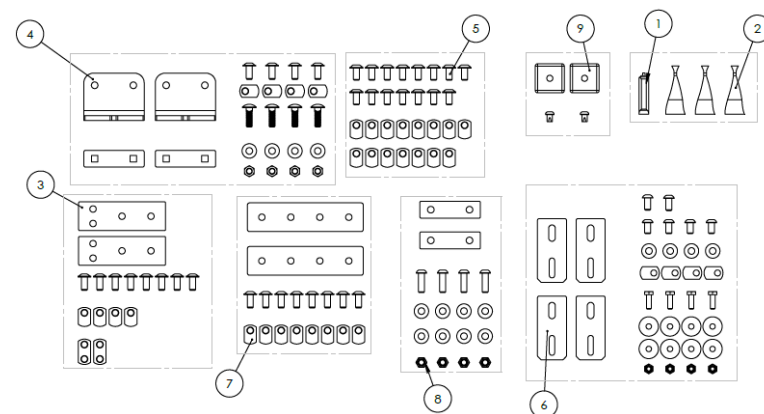

NOTES:
 1. SEE BILL OF MATERIAL FOR TOTAL KITTING QUANTITIES AS IMAGES OF EVERY INDIVIDUAL ITEM MAY NOT BE SHOWN
 2. IMAGES ARE SHOWN FOR PART IDENTIFICATION AND DO NOT REFLECT FULL QUANTITIES OF EACH PARTS, SEE SUB ASSEMBLY DRAWINGS AND BOMS FOR EXACT QUANTITIES

PACKAGING NOTES
 1. ALL ITEMS SHOULD BE PACKAGED CAREFULLY IN A SINGLE BOX.
 2. ALL ITEMS SHOULD BE PACKAGED IN A WAY THAT WILL PREVENT DAMAGE OR MOVEMENT DURING SHIPPING
 3. BOX SHOULD BE LABELED WITH SKU AND DESCRIPTION

REVISIONS				
ZONE	REV.	DESCRIPTION	DATE	APPROVED
	1	BUMPED REVISION FOR RELEASE	5/30/2023	JEO
	2	CHANGED HARDWARE KIT SET UP, TOTAL PARTS ARE IDENTICAL TO REV 1	11/8/2023	JEO

POST PROCESSING:
 FINISH: None

UNLESS OTHERWISE SPECIFIED DIMENSIONS ARE IN INCHES
 TOLERANCES:
 ANGULAR: ±0.5°
 ONE PLACE DECIMAL: ±0.1
 TWO PLACE DECIMAL: ±0.01
 THREE PLACE DECIMAL: ±0.005

DO NOT SCALE DRAWING

SECRETARY AND CONFIDENTIAL THE INFORMATION CONTAINED ON THIS DRAWING IS THE SOLE PROPERTY OF UNAKA GEAR CO. ANY REPRODUCTION OR USE OF THIS DRAWING WITHOUT THE WRITTEN PERMISSION OF UNAKA GEAR CO. IS STRICTLY PROHIBITED.

UNAKA GEAR CO.

TITLE: SPRINTER 170 HSLD HARDWARE BOX

SIZE DWG. NO. REV
 B 1006-MK51-00-HWB REV 2 2

SCALE: NTS SHEET 1 OF 2

Rack Features

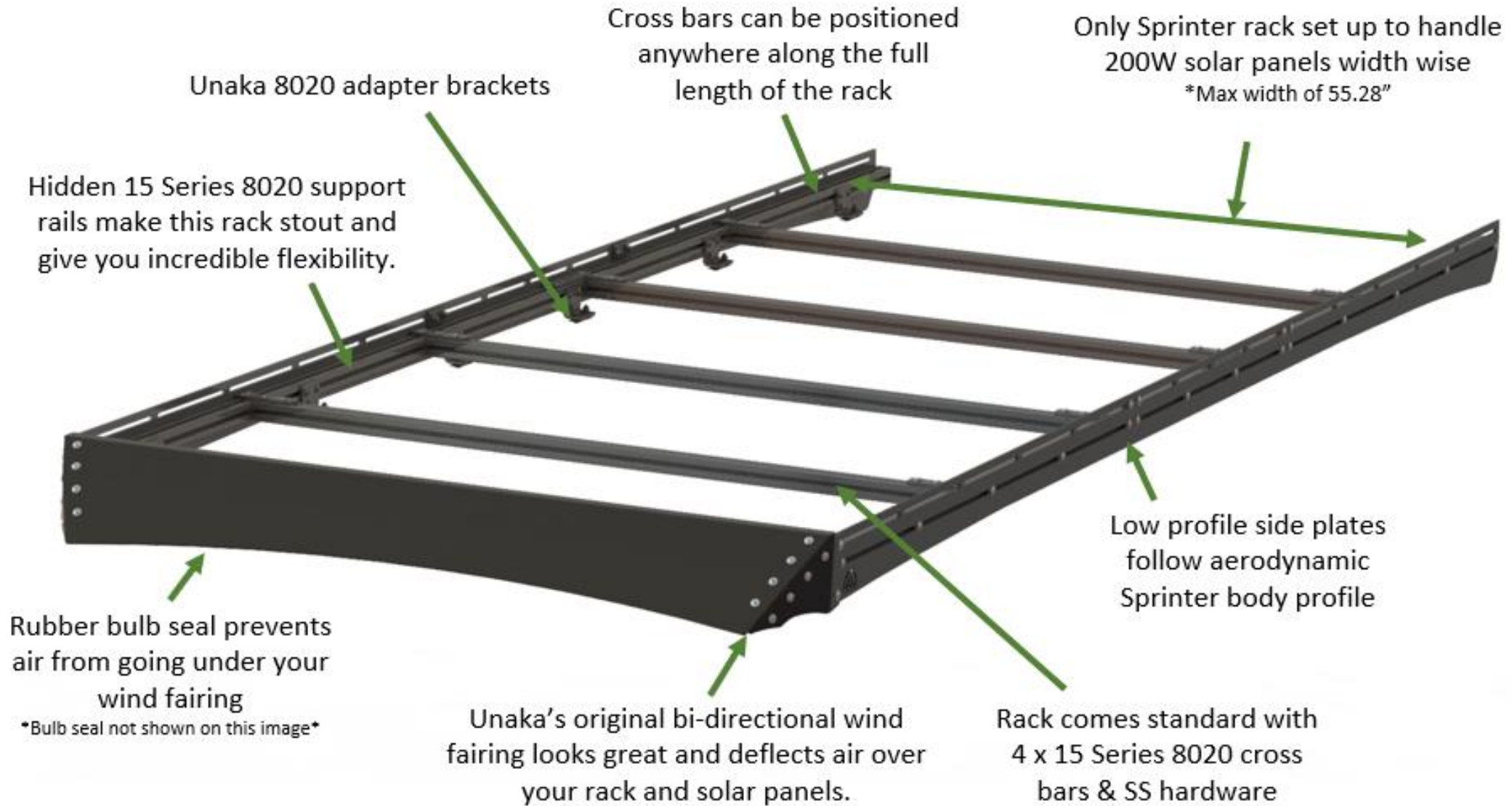

****Note: The image above is for the Sprinter 170" WB. The 144" WB and 170" WB Extended contain different side rail lengths, and different quantities of brackets and cross bars**

Rack Accessories

The HSLD rack does not include any additional accessories, and this manual does not include the installation of these accessories. **Failure to review accessory installation manuals may result in extended installation time.**

Use this link to find the manuals for any accessories and Review them before beginning this installation.
<https://unakagearco.com/pages/manuals>

Accessories Included:

- Top mount solar panel brackets for up to 400W of solar (16 brackets total)

Some of the common accessories purchased separately are listed below.

- Flush Mount Solar Panel Brackets: If you plan to install smaller solar panels on this rack, using flush mount brackets instead of top mount brackets may be desired
- Extrusion Tie Down Kits
- Sprinter Side Mount Ladder
- Awning Adapters
- More to come!

Safety and PPE

Ladders: Installation of this roof rack requires two ladders for two people to help with the installation. Make sure that your ladders are tall enough, and that you have a level area to use them on. Accessing the roof of your van will put you at extreme risk to potential falls which can result in injury or death.

Warning: Ladders are dangerous and should only be used with appropriate training. Incorrect use of ladders can result in injury or death.

Fall Protection: Accessing the roof of your van will put you at extreme risk to potential falls which can result in injury or death. Appropriate fall protection should be used when accessing your van roof. For general use situations, OSHA requires that fall protection be provided at elevations of four feet in general industry workplaces.

Required Tools

- 1 to 2 tall sturdy ladders
- Standard set of box wrenches
- Standard socket set
- 5/32" and 3/16" Allen Wrench
- Torque Wrench
- Measuring Tape

Loctite & Anti-seize

A small tube of Blue Loctite 242 and Loctite anti-seize are provided with each kit. Follow manufactures recommendation for application and safety.

Blue Loctite 242

- Apply this to any bolt that is not used with a nylock nut

Loctite Anti-seize

- Apply a dab of anti-seize to the side of each bolt that will be paired with a nylock nut. Nylock nuts have a small plastic insert to make them vibration resistant.



Loctite 242



Loctite C5-A Anti-Seize

Installation Overview

For notes on solar panel selection or installation jump to the end of this manual

1. Layout and identify all parts
 - Keep hardware separate, some types may be only slightly different and are not interchangeable
2. Assemble side rail assemblies
 - Add additional hardware to top of extrusion slot as needed for flush mount solar panel brackets or other accessories
3. Assemble cross bar assemblies
 - Add additional hardware to top of extrusion slot as needed for flush mount solar panel brackets or other accessories
4. Assemble wind fairing
5. Loosely install rack brackets on the van
6. Loosely install side rails onto roof rack brackets on van
7. Loosely install cross bars on rack
8. Loosely install wind fairing to rack side rails
9. Use cross bars and wind fairing to set the spacing of the side rails, ensuring they are parallel
10. Snug up cross bar and wind fairing hardware making rack fairly uniform
11. Tighten and torque bolts securing rack to rack brackets
12. Loosen and adjust cross bar positions as needed, install solar panels, and re-tighten everything
13. Torque all hardware

Main Rack Parts

This rack kit is typically shipped in 3 separate boxes

ITEM NO.	Manufacturer	PART NUMBER	DESCRIPTION	MATERIAL	QTY.
1	Unaka Gear Co.	1006-MA52-00-WFB REV 2	SPRINTER HSLD HIGH ROOF WIND FAIRING BOX	ASSEMBLY	1
2	Unaka Gear Co.	1006-MK51-00-HWB REV 2	SPRINTER 170 HSLD HARDWARE BOX	ASSEMBLY	1
3	Unaka Gear Co.	1006-MK51-00-MRB REV 1	SPRINTER 170 HSLD MAIN RACK BOX	ASSEMBLY	1

REVISIONS				
ZONE	REV.	DESCRIPTION	DATE	APPROVED
	0	BUMPED REVISION FOR REV CONTROL	5/30/2023	JEO
	1	SET REVISION TO 1 FOR PRODUCTION RELEASE	6/28/2023	JEO
	2	ADDED IDENTIFICATION MARK TO WIND DEFLECTOR, UPDATED HARDWARE KIT LAYOUT	11/8/2023	JEO

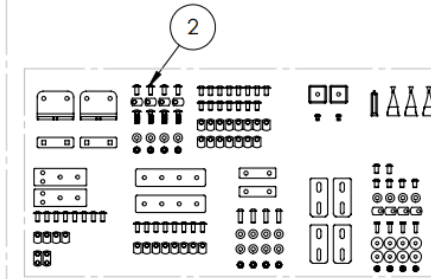
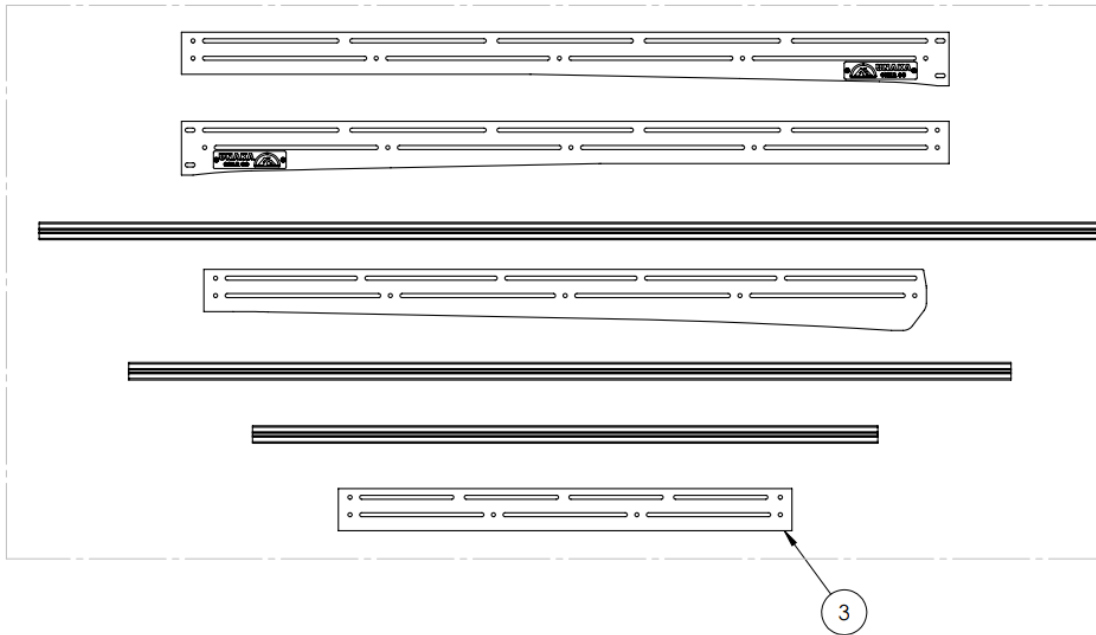
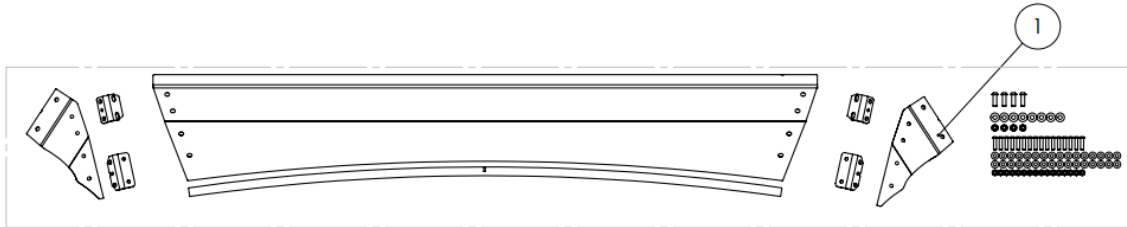

SHIPPING NOTES:

1. COMPLETE RACK KIT IS SHIPPED IN 3 SEPERATE BOXES. THE WIND FAIRING BOX CONTAINS THE WIND FAIRING & RESPECTIVE HARDWARE, THE HARDWARE BOX CONTAINS THE BRACKETS / HARDWARE, AND THE MAIN RACK BOX CONTAINS THE SIDE PLATES AND EXTRUSION.

KITTING / PACKAGING NOTES:

1. SEE BILL OF MATERIAL FOR TOTAL KITTING QUANTITIES AS IMAGES OF EVERY INDIVIDUAL ITEM MAY NOT BE SHOWN
2. IMAGES ARE SHOWN FOR PART IDENTIFICATION AND DO NOT REFLECT FULL QUANTITIES OF EACH PARTS, SEE SUB ASSEMBLY DRAWINGS AND BOMS FOR EXACT QUANTITIES

UNLESS OTHERWISE SPECIFIED DIMENSIONS ARE IN INCHES

TOLERANCES:
 ANGULAR: ±0.5°
 ONE PLACE DECIMAL: ±0.1
 TWO PLACE DECIMAL: ±0.01
 THREE PLACE DECIMAL: ±0.005

PROPRIETARY AND CONFIDENTIAL
 THE INFORMATION CONTAINED IN THIS DRAWING IS THE SOLE PROPERTY OF UNAKA GEAR CO. ANY REPRODUCTION IN PART OR AS A WHOLE WITHOUT THE WRITTEN PERMISSION OF UNAKA GEAR CO. IS STRICTLY PROHIBITED.

DO NOT SCALE DRAWING

	NAME	DATE
DRAWN	---	---
CHECKED	---	---

TITLE: **SPRINTER 170 HSLD RACK KIT**

SIZE B	DWG. NO. 1006-MK51-00 REV 2	REV 2
SCALE: NTS	SHEET 1 OF 1	

POST PROCESSING: ASSEMBLY
 FINISH: None

Main Rack Box

Contains extrusion, side plates, and cross bars: Box Size: 8" x 8" x 91" Long

ITEM NO.	Manufacturer	PART NUMBER	DESCRIPTION	MATERIAL	QTY.
1	ANY	97525A505	RIVET, BLIND, 3/16" DIA, FOR MATL 0.251"-0.375", 18-8 SS	NA	4
2	Unaka Gear Co.	1006-MB50-01 REV 1	SPRINTER HSLD FRONT SIDE PLATE	5052-H32	2
3	Unaka Gear Co.	1006-MB50-02 REV 1	SPRINTER HSLD REAR SIDE PLATE	5052-H32	2
4	Unaka Gear Co.	1006-MB50-03 REV 0	SPRINTER 170 SPLICE SIDE PLATE	5052-H32	2
5	Unaka Gear Co.	1006-MB50-04 REV 0	UNAKA HSLD LOGO PLATE	AISI 304	1
6	Unaka Gear Co.	1006-MB50-05 REV 0	UNAKA HSLD LOGO PLATE PASSENGER SIDE	AISI 304	1
7	Unaka Gear Co.	1515-UL-BLACK-53.75	8020 Style Extrusion, 15 Series, Ultra Lite, Grooved, Black, 53.75" LG.	6061 Alloy	4
8	Unaka Gear Co.	1515-UL-BLACK-75.875	8020 Style Extrusion, 15 Series, Ultra Lite, Grooved, Black, 75.875" LG.	6061 Alloy	2
9	Unaka Gear Co.	1515-UL-BLACK-91	8020 Style Extrusion, 15 Series, Ultra Lite, Grooved, Black, 91" LG.	6061 Alloy	2

REVISIONS				
ZONE	REV.	DESCRIPTION	DATE	APPROVED
	0	SET REVISION TO 0 FOR NEW DRAWING REFERENCE	5/17/2023	JEO
	1	UPDATED PROFILE OF FRONT AND REAR SIDE PLATES	6/2/2023	JEO

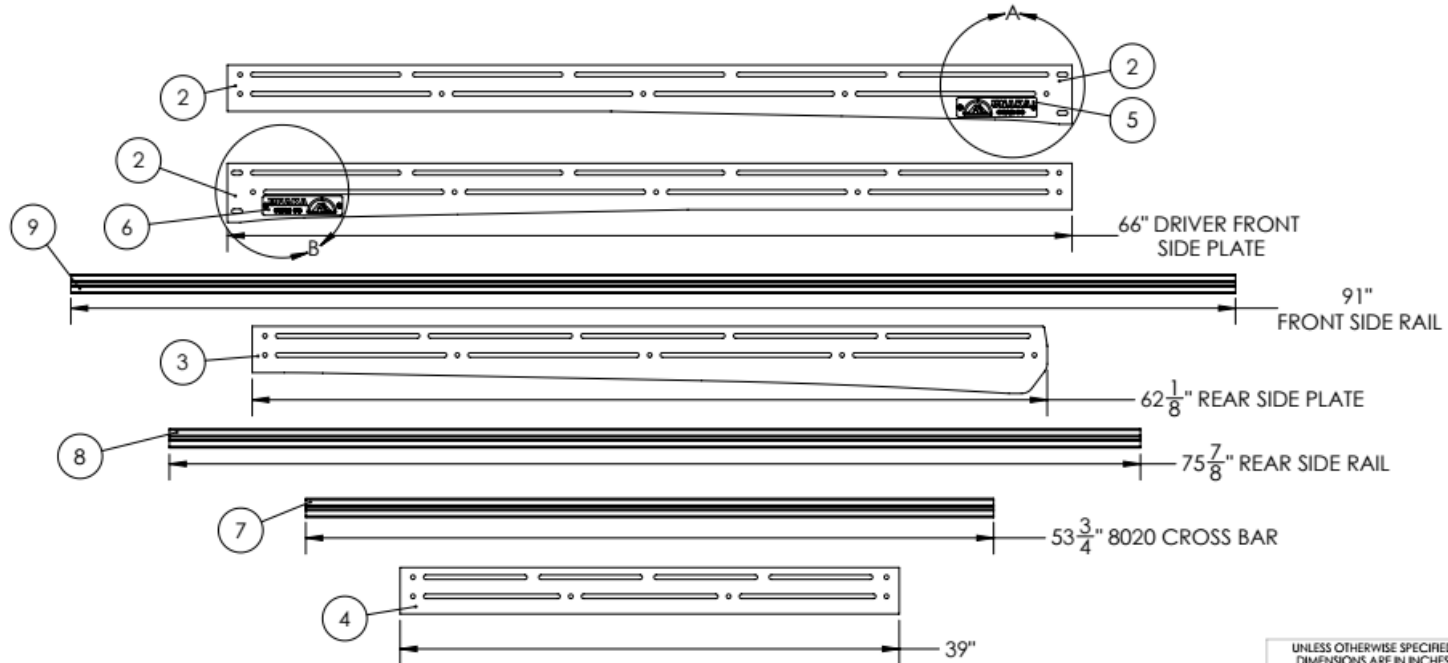
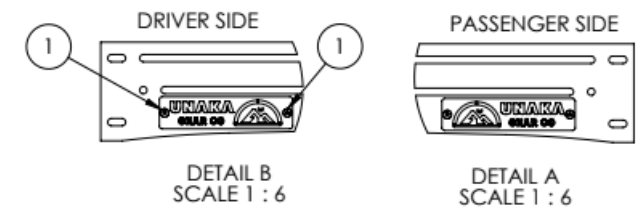

PRE-KITTING NOTES:

- LOGO PLATES (5) AND (6) SHOULD BE RIVETED TO SIDE PLATE (2) BEFORE KITTING USING SS RIVETS (1). NOTE ORIENTATION OF LOGO PLATES WITH RESPECT TO PLATES.

NOTES:

- SEE BILL OF MATERIAL FOR TOTAL KITTING QUANTITIES AS IMAGES OF EVERY INDIVIDUAL ITEM MAY NOT BE SHOWN
- IMAGES ARE SHOWN FOR PART IDENTIFICATION AND DO NOT REFLECT FULL QUANTITIES OF EACH PARTS, SEE SUB ASSEMBLY DRAWINGS AND BOMS FOR EXACT QUANTITIES

PACKAGING NOTES

- ALL ITEMS SHOULD BE PACKAGED CAREFULLY IN A SINGLE BOX.
- ALL ITEMS SHOULD BE PACKAGED IN A WAY THAT WILL PREVENT DAMAGE OR MOVEMENT DURING SHIPPING
- BOX SHOULD BE LABELED WITH SKU AND DESCRIPTION

ALL PARTS SHOULD BE WRAPPED CAREFULLY BEFORE BOXING

POST PROCESSING: None
FINISH: None

UNLESS OTHERWISE SPECIFIED DIMENSIONS ARE IN INCHES
TOLERANCES:
ANGULAR: ±0.5°
ONE PLACE DECIMAL: ±0.1
TWO PLACE DECIMAL: ±0.01
THREE PLACE DECIMAL: ±0.005

DO NOT SCALE DRAWING
NAME: JEO
DATE: ---
DRAWN BY: JEO
CHECKED: ---

TITLE: SPRINTER 170 HSLD MAIN RACK BOX

PROPRIETARY AND CONFIDENTIAL
THE INFORMATION CONTAINED IN THIS DRAWING IS THE SOLE PROPERTY OF UNAKA GEAR CO. ANY REPRODUCTION IN PART OR AS A WHOLE WITHOUT THE WRITTEN PERMISSION OF UNAKA GEAR CO. IS STRICTLY PROHIBITED.



SIZE: B
DWG. NO.: 1006-MK51-00-MRB REV 1
REV: 1
SCALE: NTS
SHEET 1 OF 1

HSLD Wind Fairing Box 1 of 2

Contains wind fairing pieces, hardware bag, and bulb seal: Box Size: 65 × 13 × 3 in

ITEM NO.	Manufacturer	PART NUMBER	DESCRIPTION	MATERIAL	QTY.
1	Unaka Gear Co.	1003-MA52-00-HW REV 0	HSLD WIND FAIRING HARDWARE KIT	ASSEMBLY	1
2	Unaka Gear Co.	1006-MB52-01 REV 0	SPRINTER HSLD WIND FAIRING TO END CAP, UPPER BRACKET	5052-H32	2
3	Unaka Gear Co.	1006-MB52-02 REV 0	SPRINTER HSLD WIND FAIRING TO END CAP, LOWER BRACKET	5052-H32	2
4	Unaka Gear Co.	1006-MB52-03 REV 1	SPRINTER HSLD WIND FAIRING END CAP DRIVER SIDE	5052-H32	1
5	Unaka Gear Co.	1006-MB52-04 REV 1	SPRINTER HSLD WIND FAIRING END CAP PASSENGER SIDE	5052-H32	1
6	Unaka Gear Co.	1006-MB52-05 REV 2	SPRINTER HSLD WIND FAIRING DEFLECTOR	5052-H32	1
7	Unaka Gear Co.	1006-MP52-06 REV 0	BULB SEAL ON SIDE, HOLLOW, FOR 3/16" EDGE, 3/4" HIGH, 51.125" LG	7100B3X3/16A	1

REVISIONS				
ZONE	REV.	DESCRIPTION	DATE	APPROVED
	0	CREATED REVISION TO START REV CONTROL	5/17/2023	JEO
	1	UPDATED PROFILE OF MAIN FAIRING AND END CAPS. ADDED BULB SEAL	6/2/2023	JEO
	2	ADDED IDENTIFICATION MARK TO MAIN DEFLECTOR	11/8/2023	JEO

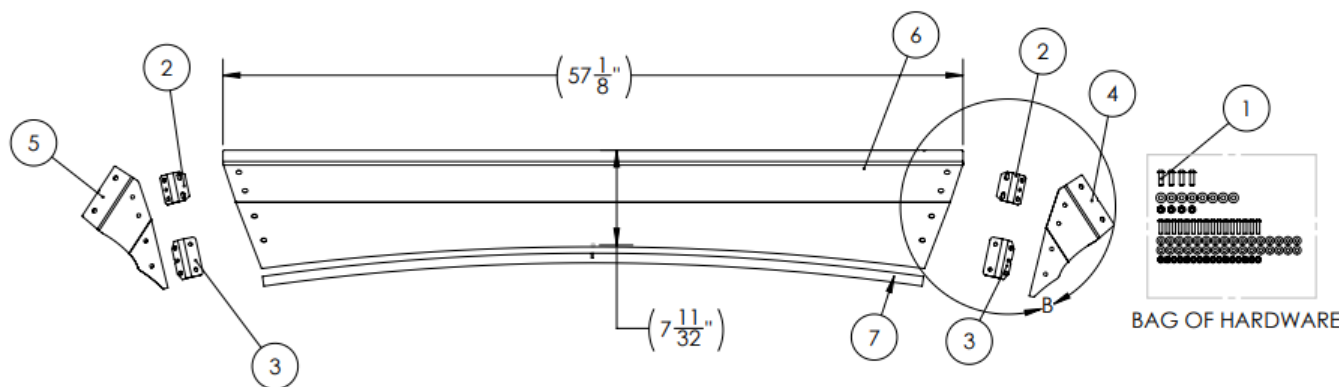

ASSEMBLY / PRE-KITTING NOTES:

- ITEM (7) SHOULD BE CUT TO APPROXIMATELY 51" LONG, AND INSTALLED ON ITEM (6) WITH THE MAIN BULB SEAL FACING BACK / DOWN

NOTES:

- SEE BILL OF MATERIAL FOR TOTAL KITTING QUANTITIES AS IMAGES OF EVERY INDIVIDUAL ITEM MAY NOT BE SHOWN IMAGES ARE SHOWN FOR PART IDENTIFICATION AND DO NOT REFLECT FULL QUANTITIES OF EACH PARTS, SEE SUB ASSEMBLY DRAWINGS AND BOMS FOR EXACT QUANTITIES

PACKAGING NOTES

- ALL ITEMS SHOULD BE PACKAGED CAREFULLY IN A SINGLE BOX.
- ALL ITEMS SHOULD BE PACKAGED IN A WAY THAT WILL PREVENT DAMAGE OR MOVEMENT DURING SHIPPING
- BOX SHOULD BE LABELED WITH SKU AND DESCRIPTION

SEE SHEET 2 FOR IDENTIFICATION MARKS CALL OUTS

UNLESS OTHERWISE SPECIFIED DIMENSIONS ARE IN INCHES		DO NOT SCALE DRAWING		TITLE:	
TOLERANCES: ANGULAR: ±0.5° ONE PLACE DECIMAL: ±0.1 TWO PLACE DECIMAL: ±0.01 THREE PLACE DECIMAL: ±0.005		NAME	DATE	SPRINTER HSLD HIGH ROOF WIND FAIRING BOX	
PROPRIETARY AND CONFIDENTIAL THE INFORMATION CONTAINED IN THIS DRAWING IS THE SOLE PROPERTY OF UNAKA GEAR CO. ANY REPRODUCTION IN PART OR AS A WHOLE WITHOUT THE WRITTEN PERMISSION OF UNAKA GEAR CO. IS STRICTLY PROHIBITED.		DRAWN BY	JEO	---	---
POST PROCESSING: None		CHECKED	---	---	---
FINISH: None		UNAKA GEAR CO		SIZE DWG. NO.	REV
				B 1006-MA52-00-WFB REV 2	2
				SCALE: NTS	SHEET 1 OF 2

**HSLD Wind
Fairing Box
2 of 2**

Contains wind fairing pieces, hardware bag, and bulb seal: Box Size: 65 × 13 × 3 in

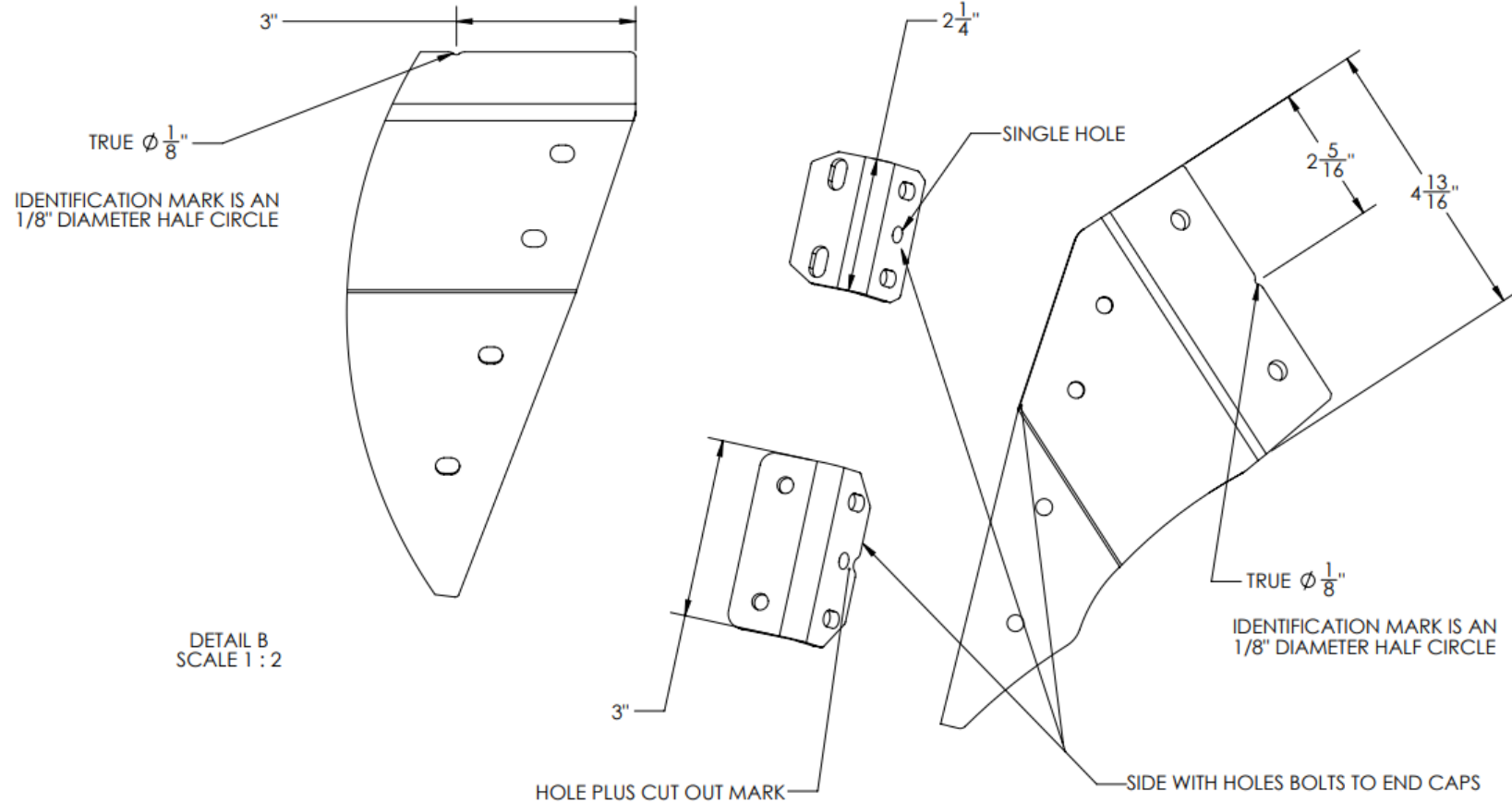

POST PROCESSING: None
FINISH: None

UNLESS OTHERWISE SPECIFIED
DIMENSIONS ARE IN INCHES

TOLEANCES:
ANGULAR: $\pm 0.5^\circ$
ONE PLACE DECIMAL: ± 0.1
TWO PLACE DECIMAL: ± 0.01
THREE PLACE DECIMAL: ± 0.005

DO NOT SCALE DRAWING		
NAME	DATE	
DRAWN BY JEO	--	
CHECKED --	--	

TITLE:
SPRINTER HSLD HIGH ROOF
WIND FAIRING BOX

PROPRIETARY AND CONFIDENTIAL
THE INFORMATION CONTAINED IN THIS
DRAWING IS THE SOLE PROPERTY OF
UNAKA GEAR CO. ANY
REPRODUCTION IN PART OR AS A WHOLE
WITHOUT THE WRITTEN PERMISSION OF
UNAKA GEAR CO. IS STRICTLY
PROHIBITED.



SIZE DWG. NO. REV
B 1006-MA52-00-WFB REV 2 **2**

SCALE: NTS SHEET 2 OF 2

HSLD Wind Fairing Hardware

Hardware required for wind fairing assembly, typically shipped in wind fairing box

ITEM NO.	Manufacturer	PART NUMBER	DESCRIPTION	MATERIAL	QTY.
1	ANY	92949A582	BHCS, 5/16-18 X 1" LG, FULLY THREADED, 18-8 S.S.	NA	4
2	ANY	92141A030	FLAT WASHER, 5/16" SCREW SIZE, 0.344" ID, 0.75" OD, 18-8 SS	NA	8
3	ANY	92949A542	BHCS, 1/4-20 X 1" LG, SS	NA	16
4	ANY	91831A029	LOCKNUT, 1/4-20, 18-8 S.S.	NA	16
5	ANY	92141A029	WASHER, 1/4", 0.625" OD, 18-8 SS	NA	32
6	ANY	91831A030	LOCKNUT, 5/16-18, 18-8 S.S.	NA	4

REVISIONS				
ZONE	REV.	DESCRIPTION	DATE	APPROVED
	0	ADDED REVISION FOR REV CONTROL	5/18/2023	JEO

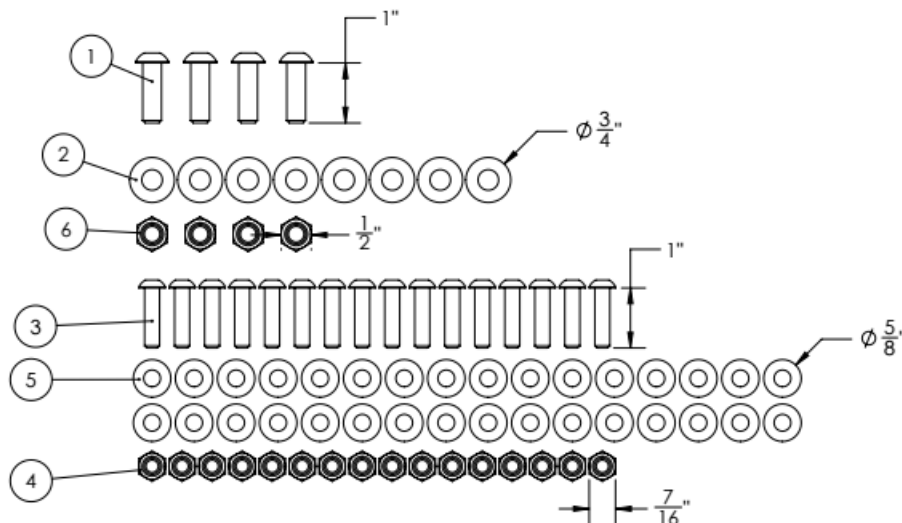

- NOTES:**
- ALL HARDWARE SHOULD BE BAGGED
 - HARDWARE BAG/BAGS SHOULD INCLUDE IDENTIFICATION LABEL

POST PROCESSING: None
FINISH: None

UNLESS OTHERWISE SPECIFIED
DIMENSIONS ARE IN INCHES

TOLERANCES:
ANGULAR: ±0.5°
ONE PLACE DECIMAL: ±0.1
TWO PLACE DECIMAL: ±0.01
THREE PLACE DECIMAL: ±0.005

PROPRIETARY AND CONFIDENTIAL
THE INFORMATION CONTAINED IN THIS
DRAWING IS THE SOLE PROPERTY OF
UNAKA GEAR CO. ANY
REPRODUCTION IN PART OR AS A WHOLE
WITHOUT THE WRITTEN PERMISSION OF
UNAKA GEAR CO. IS STRICTLY
PROHIBITED.

DO NOT SCALE DRAWING

NAME	DATE
DRAWN BY JEO	---
CHECKED	---



TITLE:
HSLD WIND FAIRING
HARDWARE KIT

SIZE DWG. NO. REV
B 1003-MA52-00-HW REV 0 0

SCALE: NTS SHEET 1 OF 1

**HSLD
Hardware
Box
1 of 2**

All remaining pieces required to assemble and install your roof rack (Typical Box: 10 × 6 × 4 in)

ITEM NO.	Manufacturer	PART NUMBER	DESCRIPTION	MATERIAL	QTY.
1	Loctite	1821A11	Antiseize, lb8008, Electrically Conductive, 0.2 oz. Pack	NA	1
2	Loctite	91458A111	Threadlocker, Loctite® 242, 0.02 FL. oz Capsule	NA	3
3	Unaka Gear Co.	1005-MK03-00-HW REV 1	CROSS BAR HARDWARE KIT FOR 4 HOLE NARROW PLATES	ASSEMBLY	4
4	UNAKA GEAR CO.	1006-MK10-00 REV 1	Sprinter Rack 8020 Adapter Bracket & Hardware - Set of 2	ASSEMBLY	5
5	Unaka Gear Co.	1006-MK52-00-HW1 REV 2	SPRINTER 170 & 170 EXTENDED HSLD SIDE RAIL HARDWARE KIT	ASSEMBLY	2
6	Unaka Gear Co.	1001-MK17-01 REV 4	TOP MOUNT SOLAR PANEL BRACKET, SET OF 4 W/8020 HARDWARE	ASSEMBLY	4
7	Unaka Gear Co.	1005-MK01-00 REV 0	Splice Plate Kit, Set of 2 x 4 Hole Flat Plates with Hardware	ASSEMBLY	1
8	Unaka Gear Co.	1005-MK07-00-HW REV 0	HSLD SIDE RAIL SPLICE PLATE HARDWARE KIT, SET OF 2	ASSEMBLY	2
9	Unaka Gear Co.	1005-MK08-00 REV 0	8020 STYLE 15 SERIES END CAPS, SET OF 2	ASSEMBLY	1

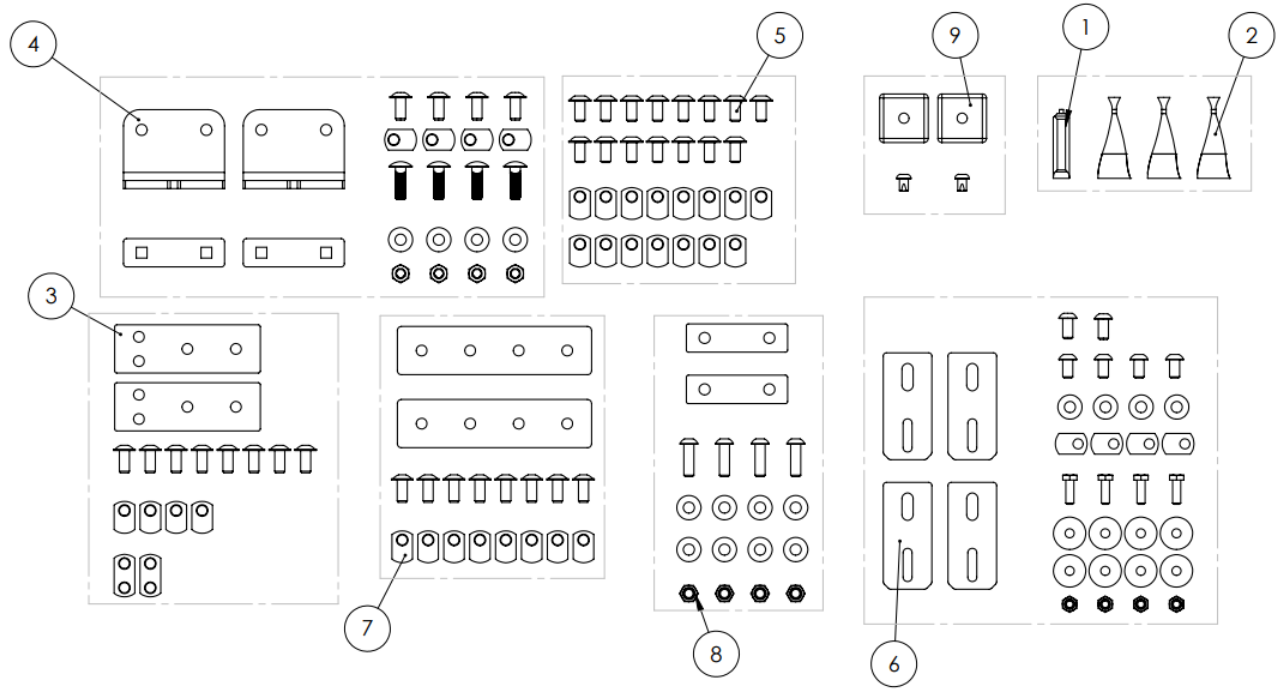

- NOTES:**
- SEE BILL OF MATERIAL FOR TOTAL KITTING QUANTITIES AS IMAGES OF EVERY INDIVIDUAL ITEM MAY NOT BE SHOWN
 - IMAGES ARE SHOWN FOR PART IDENTIFICATION AND DO NOT REFLECT FULL QUANTITIES OF EACH PARTS, SEE SUB ASSEMBLY DRAWINGS AND BOMS FOR EXACT QUANTITIES
- PACKAGING NOTES**
- ALL ITEMS SHOULD BE PACKAGED CAREFULLY IN A SINGLE BOX.
 - ALL ITEMS SHOULD BE PACKAGED IN A WAY THAT WILL PREVENT DAMAGE OR MOVEMENT DURING SHIPPING
 - BOX SHOULD BE LABELED WITH SKU AND DESCRIPTION

REVISIONS				
ZONE	REV.	DESCRIPTION	DATE	APPROVED
	1	BUMPED REVISION FOR RELEASE	5/30/2023	JEO
	2	CHANGED HARDWARE KIT SET UP, TOTAL PARTS ARE IDENTICAL TO REV 1	11/8/2023	JEO

POST PROCESSING: None
FINISH: None

UNLESS OTHERWISE SPECIFIED DIMENSIONS ARE IN INCHES		DO NOT SCALE DRAWING		TITLE:			
TOLERANCES: ANGULAR: ±0.5° ONE PLACE DECIMAL: ±0.1 TWO PLACE DECIMAL: ±0.01 THREE PLACE DECIMAL: ±0.005		NAME	DATE	SPRINTER 170 HSLD HARDWARE BOX			
PROPRIETARY AND CONFIDENTIAL THE INFORMATION CONTAINED IN THIS DRAWING IS THE SOLE PROPERTY OF UNAKA GEAR CO. ANY REPRODUCTION IN PART OR AS A WHOLE WITHOUT THE WRITTEN PERMISSION OF UNAKA GEAR CO. IS STRICTLY PROHIBITED.		DRAWN BY	JEO			SIZE	DWG. NO.
UNAKA GEAR CO.		CHECKED	---			B	1006-MK51-00-HWB REV 2
				REV	2		
				SCALE: NTS	SHEET 1 OF 2		

All remaining pieces required to assemble and install your roof rack (Typical Box: 10 × 6 × 4 in)

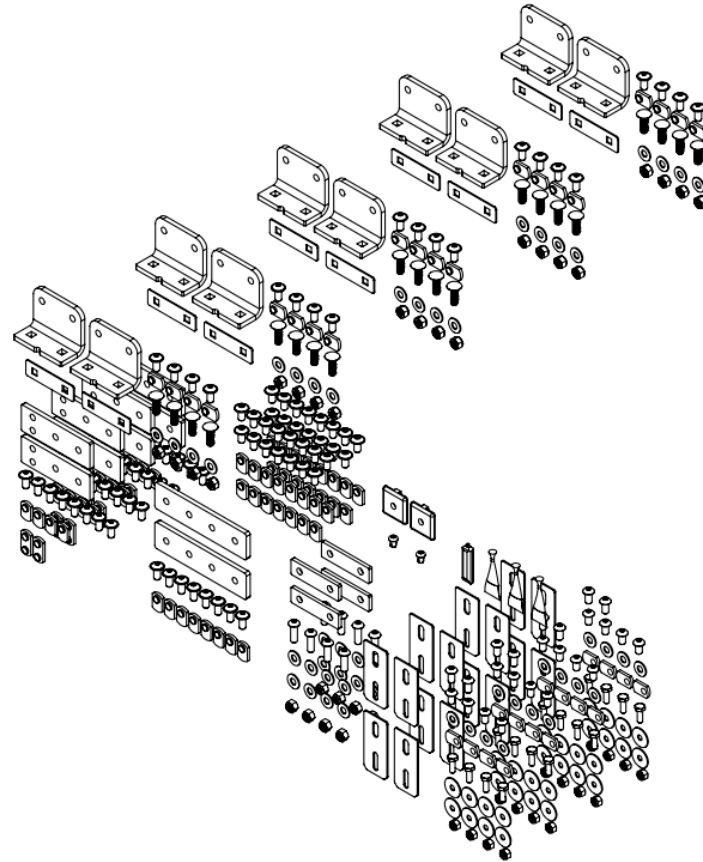

NOTES:

1. VIEW SHOWN FOR REFERENCE PURPOSES ONLY TO SHOW TOTAL PART QUANTITIES

POST PROCESSING: None
FINISH: None

UNLESS OTHERWISE SPECIFIED DIMENSIONS ARE IN INCHES	DO NOT SCALE DRAWING		TITLE:
	NAME	DATE	SPRINTER 170 HSLD HARDWARE BOX
TOLERANCES: ANGULAR: ±0.5° ONE PLACE DECIMAL: ±0.1 TWO PLACE DECIMAL: ±0.01 THREE PLACE DECIMAL: ±0.005	DRAWN BY JEO	---	SIZE DWG. NO. REV
PROPRIETARY AND CONFIDENTIAL THE INFORMATION CONTAINED IN THIS DRAWING IS THE SOLE PROPERTY OF UNAKA GEAR CO. ANY REPRODUCTION IN PART OR AS A WHOLE WITHOUT THE WRITTEN PERMISSION OF UNAKA GEAR CO. IS STRICTLY PROHIBITED.	CHECKED ---	---	B 1006-MK51-00-HWB REV 2 2
	UNAKA GEAR CO		SCALE: NTS SHEET 2 OF 2

Side Rail Hardware Bags

2 Total: 1 is used for drive side, and 1 is used for passenger side

Hardware required for assemble side rails

ITEM NO.	Manufacturer	PART NUMBER	DESCRIPTION	MATERIAL	QTY.
1	ANY	3678	T-NUT, ECONOMY, 5/16 THREAD, SS	NA	15
2	ANY	97654A304-B	BHCS, FLANGED, 5/16 X 0.625" LG., S.S., BLACK	NA	15

REVISIONS				
ZONE	REV.	DESCRIPTION	DATE	APPROVED
	0	BUMPED REVISION FOR REV CONTROL	5/30/23	JEO
	1	SET TO REV 1 FOR FIRST BUILD RELEASE	6/7/2023	JEO
	2	MOVED SPACERS, END CAPS, AND OTHER HARDWARE TO OTHER KITS	11/8/2023	JEO

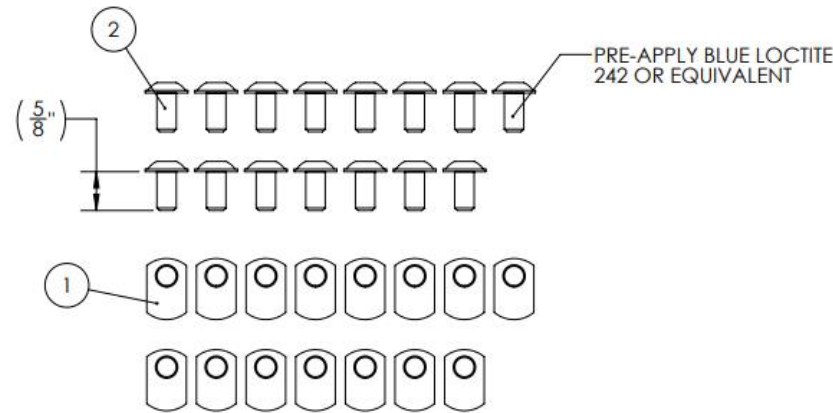

SPRINTER 170 & 170 EXTENDED NOTES:

- QUANTITY 1 OF ITEM (2) AND ITEM (1) ARE NOT USED ON THE SPRINTER 170 SIDE RAILS
- ALL HARDWARE IS USED FOR THE SPRINTER 170 EXTENDED SIDE RAILS

NOTES:

- ALL HARDWARE SHOULD BE BAGGED
- HARDWARE BAG/BAGS SHOULD INCLUDE IDENTIFICATION LABEL

POST PROCESSING: None
FINISH: None

UNLESS OTHERWISE SPECIFIED DIMENSIONS ARE IN INCHES

TOLERANCES:
ANGULAR: ±0.5°
ONE PLACE DECIMAL: ±0.1
TWO PLACE DECIMAL: ±0.01
THREE PLACE DECIMAL: ±0.005

PROPRIETARY AND CONFIDENTIAL

THE INFORMATION CONTAINED IN THIS DRAWING IS THE SOLE PROPERTY OF UNAKA GEAR CO. ANY REPRODUCTION IN PART OR AS A WHOLE WITHOUT THE WRITTEN PERMISSION OF UNAKA GEAR CO. IS STRICTLY PROHIBITED.

DO NOT SCALE DRAWING

	NAME	DATE
DRAWN BY	JEO	---
CHECKED	---	---



TITLE:

SPRINTER 170 & 170
EXTENDED HSLD SIDE RAIL
HARDWARE KIT

SIZE DWG. NO. REV
B 1006-MK52-00-HW1 REV 2 2

SCALE: NTS SHEET 1 OF 1

Rack Bracket & Hardware

Quantity 5
Total

Hardware required for bolt brackets to van roof rails, and brackets to 8020 side

ITEM NO.	Manufacturer	PART NUMBER	DESCRIPTION	MATERIAL	QTY.
1	8020	3607	BHCS, FLANGED, 5/16 X 0.687" LG., S.S.	NA	4
2	8020	3678	T-NUT, ECONOMY, 5/16 THREAD, SS	NA	4
3	ANY	91831A030	LOCKNUT, 5/16-18, 18-8 S.S.	NA	4
4	ANY	92141A030	FLAT WASHER, 5/16" SCREW SIZE, 0.344" ID, 0.75" OD, 18-8 SS	NA	4
5	ANY	92356A583	CARRIAGE BOLT, 5/16"-18 X 1" LG, 18-8 SS	NA	4
6	Unaka Gear Co.	1006-MB10-01 REV A	SPRINTER ROOF RAIL 8020 BRACKET	5052-H32	2
7	Unaka Gear Co.	1006-MB10-02	SPRINTER RACK RAIL DOUBLE WASHER, 2" SPACING	AISI 304	2

REVISIONS				
ZONE	REV.	DESCRIPTION	DATE	APPROVED
	A	REVISION A FOR UPDATED HARDWARE	12/9/2022	JEO
	1	CHANGED DRAWING LAYOUT TO SHOW ALL PARTS	7/10/2023	JEO

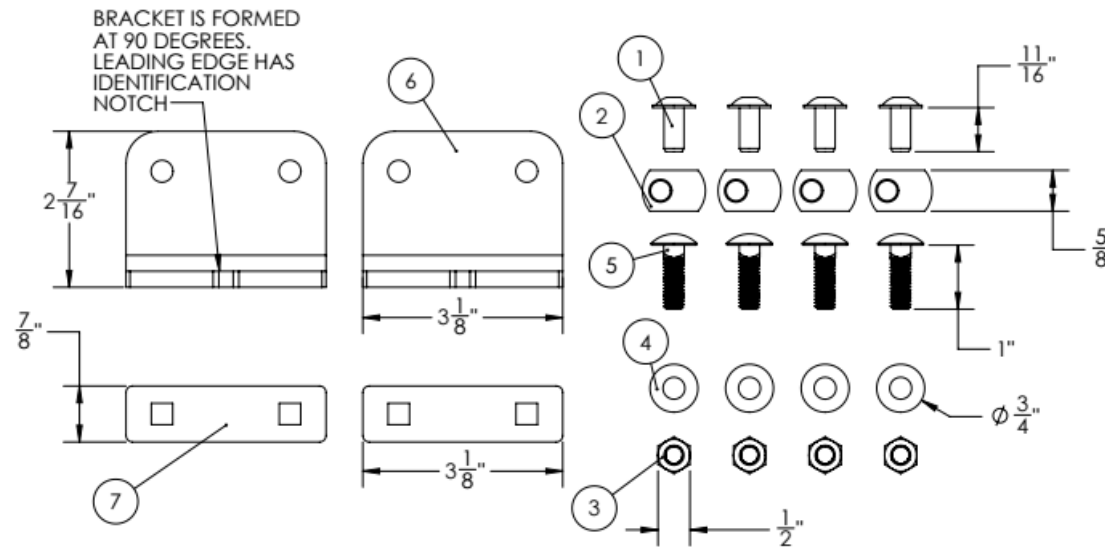

KITTING NOTES:

1. LABEL AND BAG HARDWARE
2. WRAP OR BOX BOTH BRACKETS AND HARDWARE
3. LABEL COMPLETE KIT / BOX

UNLESS OTHERWISE SPECIFIED DIMENSIONS ARE IN INCHES		DO NOT SCALE DRAWING		TITLE:	
TOLERANCES:		NAME	DATE	Sprinter Rack 8020 Adapter Bracket & Hardware - Set of 2	
ANGULAR: ±0.5°		DRAWN	---		
ONE PLACE DECIMAL: ±0.1		CHECKED	---		
TWO PLACE DECIMAL: ±0.01				SIZE	DWG. NO.
THREE PLACE DECIMAL: ±0.005				B	1006-MK10-00 REV 1
<p>PROPRIETARY AND CONFIDENTIAL</p> <p>THE INFORMATION CONTAINED IN THIS DRAWING IS THE SOLE PROPERTY OF UNAKA GEAR CO. ANY REPRODUCTION IN PART OR AS A WHOLE WITHOUT THE WRITTEN PERMISSION OF UNAKA GEAR CO. IS STRICTLY PROHIBITED.</p>				REV	1
POST PROCESSING: ASSEMBLY		FINISH: None		SCALE: NTS	SHEET 1 OF 1

Top Mount Solar Panel Bracket Kits

4 Total: 8 Brackets per 200W Solar Panel

Hardware top mount solar panel brackets

ITEM NO.	Manufacturer	PART NUMBER	DESCRIPTION	MATERIAL	QTY.
1	UNAKA GEAR CO.	1001-MB17-01 REV 1	SOLAR PANEL TOP MOUNT BRACKET	AISI 304	4
2	Unaka Gear Co	1001-MK27-00-HW REV 0	HARDWARE FOR QTY 4 TOP MOUNT OR FLUSH MOUNT PANEL BRACKETS	ASSEMBLY	1

REVISIONS				
ZONE	REV.	DESCRIPTION	DATE	APPROVED
	1	CREATED REV 1 FOR REVISION CONTROL. UPDATED HARDWARE FROM 2 SETS OF BRACKETS TO 4	6/23/2023	JEO
	2	ADDED 5/16-18 X 5/8 BHCS. CHANGED PROFILE OF BRACKET, ELIMINATED EXTRA HARDWARE	7/21/2023	JEO
	3	ADDED THREAD LOCK NOTE, AND UPDATED PART NUMBERS TO SHOW BO FOR BLACK OXIDE	8/1/2023	JEO
C6	4	MOVED ALL HARDWARE TO SUB KIT	8/15/2023	JEO

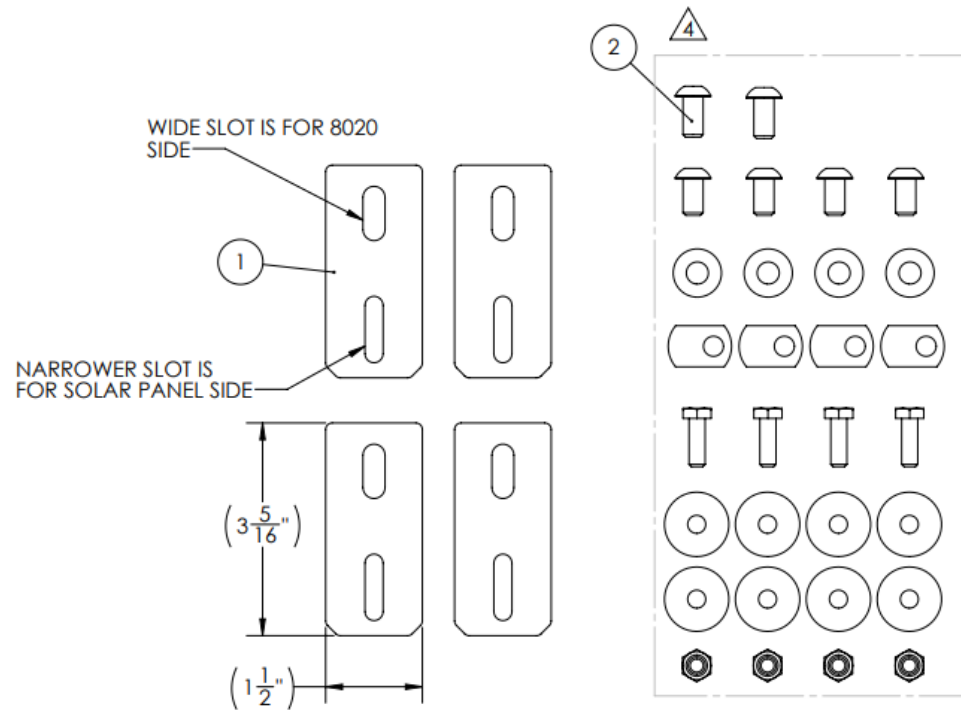

PLACE ALL HARDWARE IN A LABELED

KITTING NOTES:

1. LOCKTITE: 5/16-18 BHCS BOLTS SHOULD HAVE THREADLOCK PRE-APPLIED BEFORE BAGGING
2. PLACE ALL HARDWARE IN A SINGLE LABELED HARDWARE BAG
3. PLACE BAG OF HARDWARE AND BRACKETS INTO A LABELED BOX
4. IF LABELED BOX IS NOT AN OPTION, STACK BRACKETS, AND SHRINK WRAP HARDWARE BAG TO BRACKETS

UNLESS OTHERWISE SPECIFIED DIMENSIONS ARE IN INCHES TOLERANCES: ANGULAR: ±0.5° ONE PLACE DECIMAL: ±0.1 TWO PLACE DECIMAL: ±0.01 THREE PLACE DECIMAL: ±0.005	DO NOT SCALE DRAWING		TITLE: TOP MOUNT SOLAR PANEL BRACKET, SET OF 4 W/8020 HARDWARE	
	DRAWN	NAME	DATE	
PROPRIETARY AND CONFIDENTIAL THE INFORMATION CONTAINED IN THIS DRAWING IS THE SOLE PROPERTY OF UNAKA GEAR CO. ANY REPRODUCTION IN PART OR AS A WHOLE WITHOUT THE WRITTEN PERMISSION OF UNAKA GEAR CO. IS STRICTLY PROHIBITED.	CHECKED			
			SIZE DWG. NO. REV B 1001-MK17-01 REV 4 4	SCALE: NTS SHEET 1 OF 1

POST PROCESSING: ASSEMBLY
FINISH: None

Top Mount Solar Panel Hardware Kits

1 Total: 2 kits per 200W Solar Panel

Top mount solar panel bracket hardware kit

ITEM NO.	Manufacturer	PART NUMBER	DESCRIPTION	MATERIAL	QTY.
1	8020	3678	T-NUT, ECONOMY, 5/16 THREAD, SS	NA	4
2	ANY	90313A107	WASHER, 1/4" X 1" OD, 18-8 SS	NA	8
3	ANY	91831A029	LOCKNUT, 1/4-20, 18-8 S.S.	NA	4
4	ANY	92141A030-BO	FLAT WASHER, 5/16" SCREW SIZE, 0.344" ID, 0.75" OD, 18-8 SS	NA	4
5	ANY	92240A540	HEX BOLT, 1/4-20 X 0.75" FULLY THREADED, 18-8 S.S.	NA	4
6	ANY	92949A580-BO	BHCS, 5/16-18 X 5/8" LG, FULL THREAD, 18-8 SS	NA	2
7	ANY	92949A853-BO	BHCS, 5/16-18 X 0.5625" LG, FULLY THREADED, 18-8 S.S.	NA	4

REVISIONS				
ZONE	REV.	DESCRIPTION	DATE	APPROVED
	0	CREATED REV 1 FOR REVISION CONTROL	8/2/2023	JEO

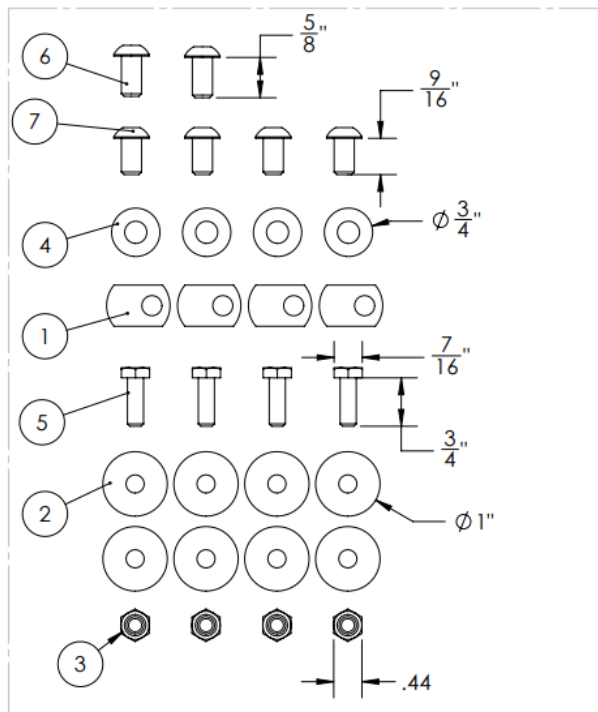

ASSEMBLY NOTES: ITEM 6 IS ONLY USED WHEN TWO BRACKETS ARE BEING BOLTED ON TOP OF EACH OTHER

PLACE ALL HARDWARE IN A BAG, LABEL BAG 1001-MK27-00-HW "HARDWARE FOR SET OF 4 TOP MOUNT OR FLUSH MOUNT BRACKETS)

- KITTING NOTES:**
- LOCKTITE: ITEMS 6 AND 7 SHOULD HAVE THREADLOCK PRE-APPLIED BEFORE BAGGING
 - PLACE ALL HARDWARE IN A SINGLE LABELED HARDWARE BAG

<small>UNLESS OTHERWISE SPECIFIED DIMENSIONS ARE IN INCHES</small> TOLERANCES: ANGULAR: ±0.5° ONE PLACE DECIMAL: ±0.1 TWO PLACE DECIMAL: ±0.01 THREE PLACE DECIMAL: ±0.005	DO NOT SCALE DRAWING		TITLE: HARDWARE FOR QTY 4 TOP MOUNT OR FLUSH MOUNT PANEL BRACKETS					
	<table border="1"> <tr> <th>NAME</th> <th>DATE</th> </tr> <tr> <td>DRAWN</td> <td>---</td> </tr> <tr> <td>CHECKED</td> <td>---</td> </tr> </table>	NAME		DATE	DRAWN	---	CHECKED	---
NAME	DATE							
DRAWN	---							
CHECKED	---							
<small>PROPRIETARY AND CONFIDENTIAL</small> THE INFORMATION CONTAINED IN THIS DRAWING IS THE SOLE PROPERTY OF UNAKA GEAR CO. ANY REPRODUCTION IN PART OR AS A WHOLE WITHOUT THE WRITTEN PERMISSION OF UNAKA GEAR CO. IS STRICTLY PROHIBITED.			SIZE B DWG. NO. 1001-MK27-00-HW REV 0					
			POST PROCESSING: ASSEMBLY FINISH: None	REV 0 SCALE: NTS SHEET 1 OF 1				

Cross Bar Hardware

Quantity 4
Total

CROSS BAR HARDWARE KIT

ITEM NO.	Manufacturer	PART NUMBER	DESCRIPTION	MATERIAL	QTY.
1	Any	3678	T-NUT, ECONOMY, 5/16 THREAD, SS	NA	4
2	Any	3607-B	BHCS, FLANGED, 5/16 X 0.687" LG., S.S., BLACK	NA	8
3	Unaka Gear Co.	1005-MB03-01 REV 0	STRAIGHT FLAT PLATE, 15 SERIES, 4 HOLE	6061 Alloy	2
4	Unaka Gear Co.	1005-MP00-01 REV 0	DOUBLE T-NUT, 15 SERIES, ECONOMY, 5/16-18 THREAD, SS	AISI 304	2

REVISIONS				
ZONE	REV.	DESCRIPTION	DATE	APPROVED
	0	BUMPED REVISION FOR RELEASE	5/30/2023	JEO
	1	UPDATED HARDWARE TO USE DOUBLE T-NUT	8/31/2023	JEO

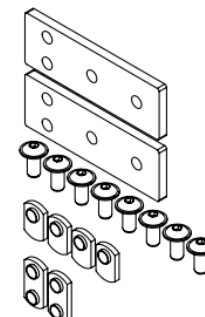
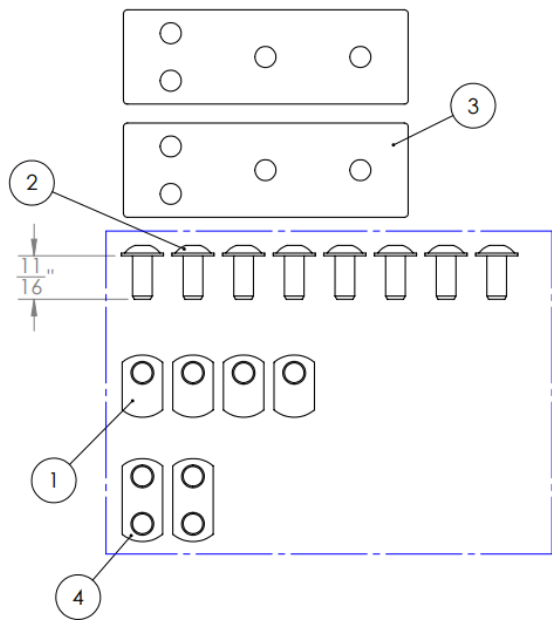

ALL KIT PARTS SHOWN

KITTING NOTES:

1. HARDWARE SHOULD BE BAGGED
2. HARDWARE BAG SHOULD BE LABELED
3. ALL PARTS SHOULD BE PACKAGED WITH THE PART NUMBER AND DESCRIPTION LOCATED LABELED ON THE OUTSIDE OF THE PACKAGE
4. IF FORMAL PACKAGE DESIGN HAS NOT BE PROVIDED, CAREFULLY WRAP BAG OF HARDWARE TO BRACKETS USING SHRINK WRAP, AND APPLY LABEL TO OUTSIDE

<small>UNLESS OTHERWISE SPECIFIED DIMENSIONS ARE IN INCHES</small> TOLERANCES: ANGULAR: ±0.5° ONE PLACE DECIMAL: ±0.1 TWO PLACE DECIMAL: ±0.01 THREE PLACE DECIMAL: ±0.005	DO NOT SCALE DRAWING		TITLE:	
	NAME	DATE	CROSS BAR HARDWARE KIT FOR 4 HOLE NARROW PLATES	
PROPRIETARY AND CONFIDENTIAL <small>THE INFORMATION CONTAINED IN THIS DRAWING IS THE SOLE PROPERTY OF UNAKA GEAR CO. ANY REPRODUCTION IN PART OR AS A WHOLE WITHOUT THE WRITTEN PERMISSION OF UNAKA GEAR CO. IS STRICTLY PROHIBITED.</small>	DRAWN BY	JEO	---	SIZE
	CHECKED	---	---	DWG. NO.
POST PROCESSING: None FINISH: None			DWG. NO. 1005-MK03-00-HW REV 1 SCALE: NTS	REV 1 SHEET 1 OF 1

Splice Plate Hardware

Quantity 1
Total

SIDE RAIL SPLICE PLATE HARDWARE KIT

ITEM NO.	Manufacturer	PART NUMBER	DESCRIPTION	MATERIAL	QTY.
1	ANY	3678	T-NUT, ECONOMY, 5/16 THREAD, SS	NA	8
2	Any	3607	BHCS, FLANGED, 5/16 X 0.687" LG., S.S., BLACK	NA	8
3	Unaka Gear Co.	1005-MB01-01	STRAIGHT FLAT PLATE, 15 SERIES, 4 HOLE	6061 Alloy	2

REVISIONS				
ZONE	REV.	DESCRIPTION	DATE	APPROVED
	0	BUMPED REVISION FOR RELEASE	9/11/2023	JEO

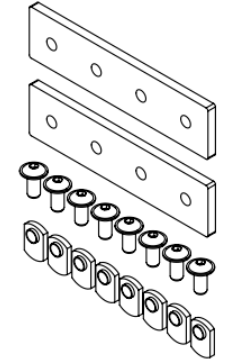
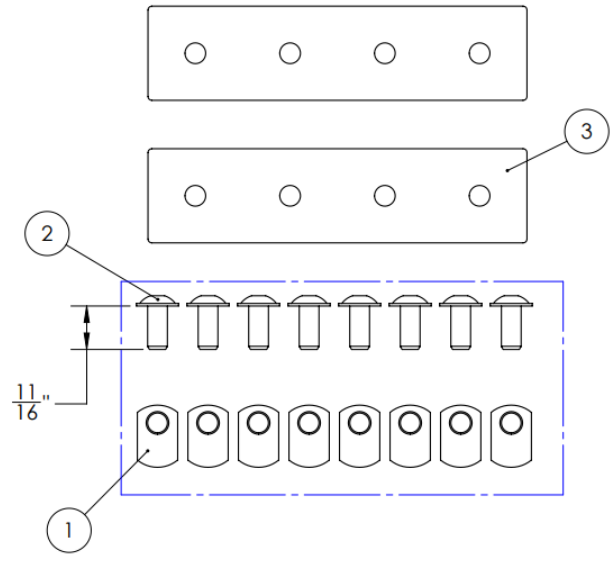

ALL KIT PARTS SHOWN

FINISH NOTES:

- 3607 FINISH SHOULD BE BLACK & HAVE PRE-APPLIED THREAD LOCK TO THREADS
- 4 HOLE PLATE SHOULD BE UV RESISTANT BLACK POWDER COAT

KITTING NOTES:

- HARDWARE SHOULD BE BAGGED
- HARDWARE BAG SHOULD BE LABELED
- ALL PARTS SHOULD BE PACKAGED WITH THE PART NUMBER AND DESCRIPTION LOCATED LABELED ON THE OUTSIDE OF THE PACKAGE
- IF FORMAL PACKAGE DESIGN HAS NOT BE PROVIDED, CAREFULLY WRAP BAG OF HARDWARE TO BRACKETS USING SHRINK WRAP, AND APPLY LABEL TO OUTSIDE

POST PROCESSING: None
FINISH: None

UNLESS OTHERWISE SPECIFIED DIMENSIONS ARE IN INCHES
TOLERANCES:
ANGULAR: ±0.5°
ONE PLACE DECIMAL: ±0.1
TWO PLACE DECIMAL: ±0.01
THREE PLACE DECIMAL: ±0.005

DO NOT SCALE DRAWING		
NAME	DATE	
DRAWN BY: JEO	---	
CHECKED: ---	---	

PROPRIETARY AND CONFIDENTIAL
THE INFORMATION CONTAINED IN THIS DRAWING IS THE SOLE PROPERTY OF UNAKA GEAR CO. ANY REPRODUCTION IN PART OR AS A WHOLE WITHOUT THE WRITTEN PERMISSION OF UNAKA GEAR CO. IS STRICTLY PROHIBITED.



TITLE:
Splice Plate Kit, Set of 2 x 4 Hole Flat Plates with Hardware

SIZE B	DWG. NO. 1005-MK01-00 REV 0	REV 0
---------------	-----------------------------	--------------

SCALE: NTS SHEET 1 OF 1

Side Plate Hardware

Quantity 2
Total

SIDE PLATE SPLICE HARDWARE KIT

ITEM NO.	Manufacturer	PART NUMBER	DESCRIPTION	MATERIAL	QTY.
1	ANY	91831A030	LOCKNUT, 5/16-18, 18-8 S.S.	NA	4
2	ANY	92141A030-B	FLAT WASHER, 5/16" SCREW SIZE, 0.344" ID, 0.75" OD, 18-8 SS, BLACK	NA	8
3	ANY	92949A582-B	BHCS, 5/16-18 X 1" LG, FULLY THREADED, 18-8 S.S., BLACK	NA	4
4	Unaka Gear Co.	1006-MB50-06 REV 0	SPRINTER HSLD SIDE RAIL SPLICE PLATE	5052-H32	2

REVISIONS				
ZONE	REV.	DESCRIPTION	DATE	APPROVED
	0	BUMPED REVISION FOR REV CONTROL	10/26/2023	JEO

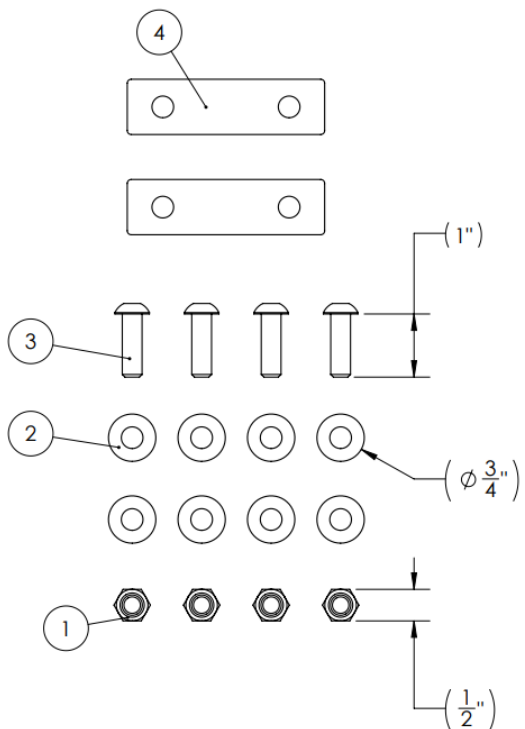

- KITTING NOTES:**
- ALL HARDWARE SHOULD BE BAGGED
 - ALL TYPES OF HARDWARE CAN BE BAGGED IN A SINGLE BAG, OR IN INDIVIDUAL BAGS BASED ON HARDWARE SIZE THEN PLACED IN A LARGER BAG
 - MAIN HARDWARE BAG SHOULD INCLUDE IDENTIFICATION LABEL

<small>UNLESS OTHERWISE SPECIFIED DIMENSIONS ARE IN INCHES</small> TOLERANCES: ANGULAR: ±0.5° ONE PLACE DECIMAL: ±0.1 TWO PLACE DECIMAL: ±0.01 THREE PLACE DECIMAL: ±0.005	DO NOT SCALE DRAWING		TITLE: HSLD SIDE RAIL SPLICE PLATE HARDWARE KIT, SET OF 2
	NAME DRAWN BY: JEO CHECKED: ---	DATE ---	
<small>PROPRIETARY AND CONFIDENTIAL</small> <small>THE INFORMATION CONTAINED IN THIS DRAWING IS THE SOLE PROPERTY OF UNAKA GEAR CO. ANY REPRODUCTION IN PART OR AS A WHOLE WITHOUT THE WRITTEN PERMISSION OF UNAKA GEAR CO. IS STRICTLY PROHIBITED.</small>			REV: 0 SHEET 1 OF 1

POST PROCESSING: None
FINISH: None

End Cap Hardware

END CAP HARDWARE KIT

Quantity 1
Total

ITEM NO.	Manufacturer	PART NUMBER	DESCRIPTION	MATERIAL	QTY.
1	8020	203001-PLAIN	END CAP, 15 SERIES, PLAIN, BLACK	NA	2
2	8020	3267	SELF TAPPING END CAP SCREW, M7 X 0.36"	NA	2

REVISIONS				
ZONE	REV.	DESCRIPTION	DATE	APPROVED
	0	BUMPED REVISION FOR REV CONTROL	10/26/2023	JEO

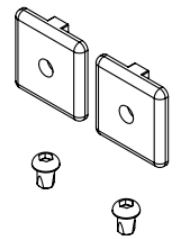
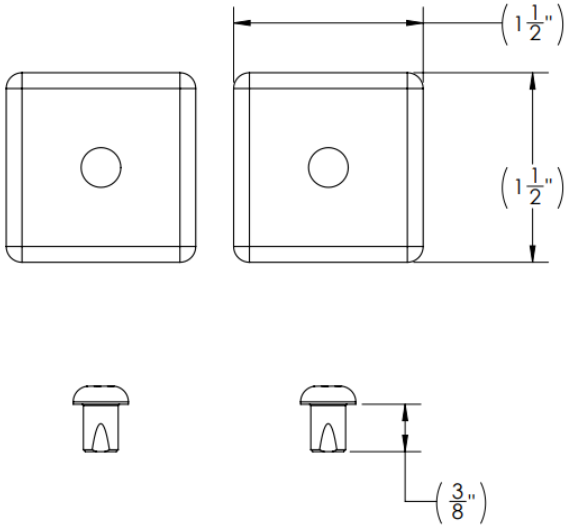

- NOTES:**
1. PLACE END CAPS AND SELF TAPPING SCREWS IN A SINGLE BAG
 2. APPLY SKU LABEL TO OUTSIDE OF BAG

POST PROCESSING: None
FINISH: None

<small>UNLESS OTHERWISE SPECIFIED DIMENSIONS ARE IN INCHES</small> TOLERANCES: ANGULAR: ±0.5° ONE PLACE DECIMAL: ±0.1 TWO PLACE DECIMAL: ±0.01 THREE PLACE DECIMAL: ±0.005	DO NOT SCALE DRAWING		TITLE:						
	<table border="1"> <tr> <td>NAME</td> <td>DATE</td> </tr> <tr> <td>DRAWN BY: JEO</td> <td>---</td> </tr> <tr> <td>CHECKED</td> <td>---</td> </tr> </table>	NAME	DATE	DRAWN BY: JEO	---	CHECKED	---	8020 STYLE 15 SERIES END CAPS, SET OF 2	
NAME	DATE								
DRAWN BY: JEO	---								
CHECKED	---								
<small>PROPRIETARY AND CONFIDENTIAL</small> THE INFORMATION CONTAINED IN THIS DRAWING IS THE SOLE PROPERTY OF UNAKA GEAR CO. ANY REPRODUCTION IN PART OR AS A WHOLE WITHOUT THE WRITTEN PERMISSION OF UNAKA GEAR CO. IS STRICTLY PROHIBITED.			SIZE B	DWG. NO. 1005-MK08-00 REV 0	REV 0				
	SCALE: NTS		SHEET 1 OF 1						

Extrusion T-Nut Installation Overview: Part # 3678 or similar

1. T-nuts are used to connect 8020 style extrusion and other components
2. When installing T-nuts, leave the flat side towards the outside of the extrusion, and have the boss facing the center of the extrusion
3. Once inside the extrusion, slide the t-nut to the desired location

Correct way to Orient T-nuts when sliding into extrusion

T-Nut Boss faces
center of extrusion

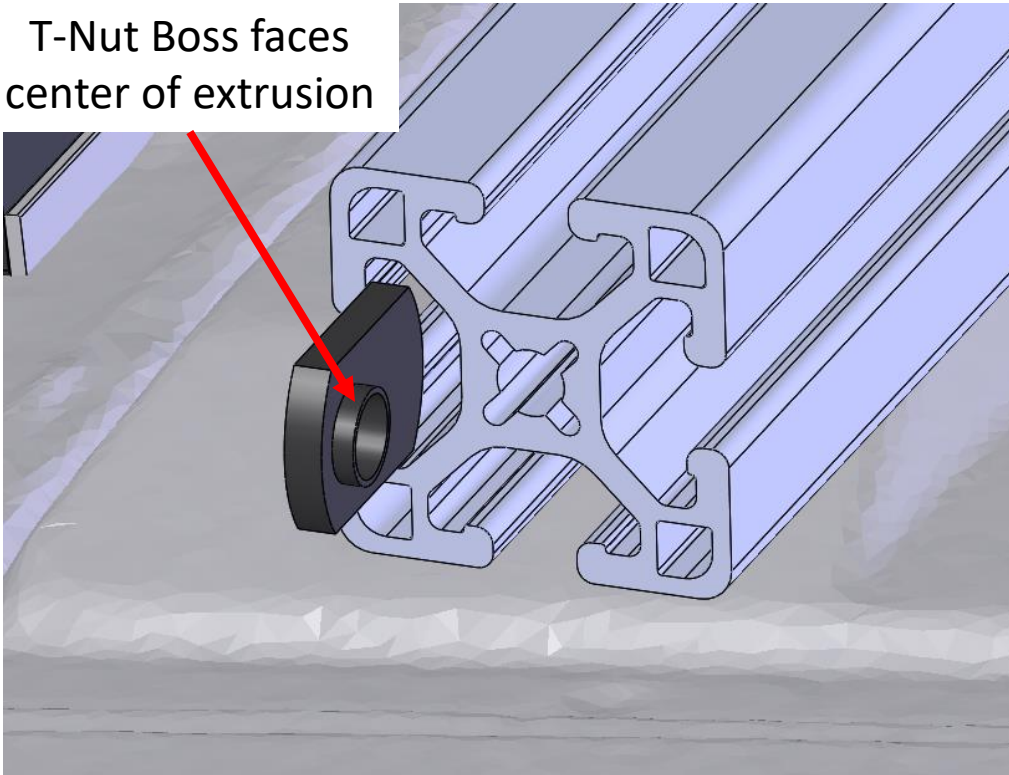

Extrusion T-Nut Installation Overview: Part # 3678 or similar

1. One side of the t-nut is longer than the other so installation orientation is critical
2. Note, the example below is just one portion of the rack shown as an example, but the same principle may apply to other locations
3. When the long side is pointed at the long side of another t-nut, in some cases they can physically interfere
4. When the long side is pointed at the end of the extrusion, in some cases they can extend past, and physically prevent 1 piece from correctly touching the other
5. In most cases if a t-nut creates an interference, reversing its orientation will solve the issue

Correct way to Orient T-nuts to prevent interferences

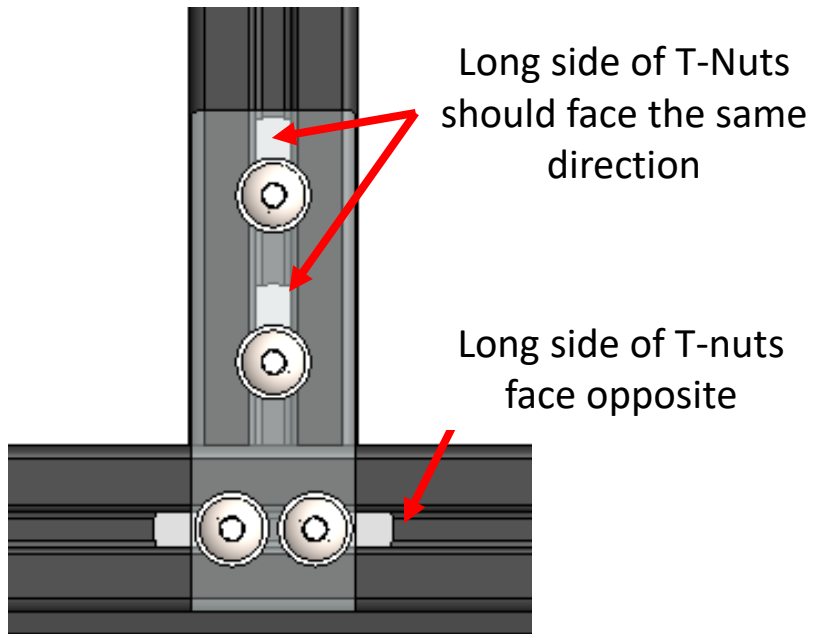

Warning: T-nuts installed in the orientation below will create interferences

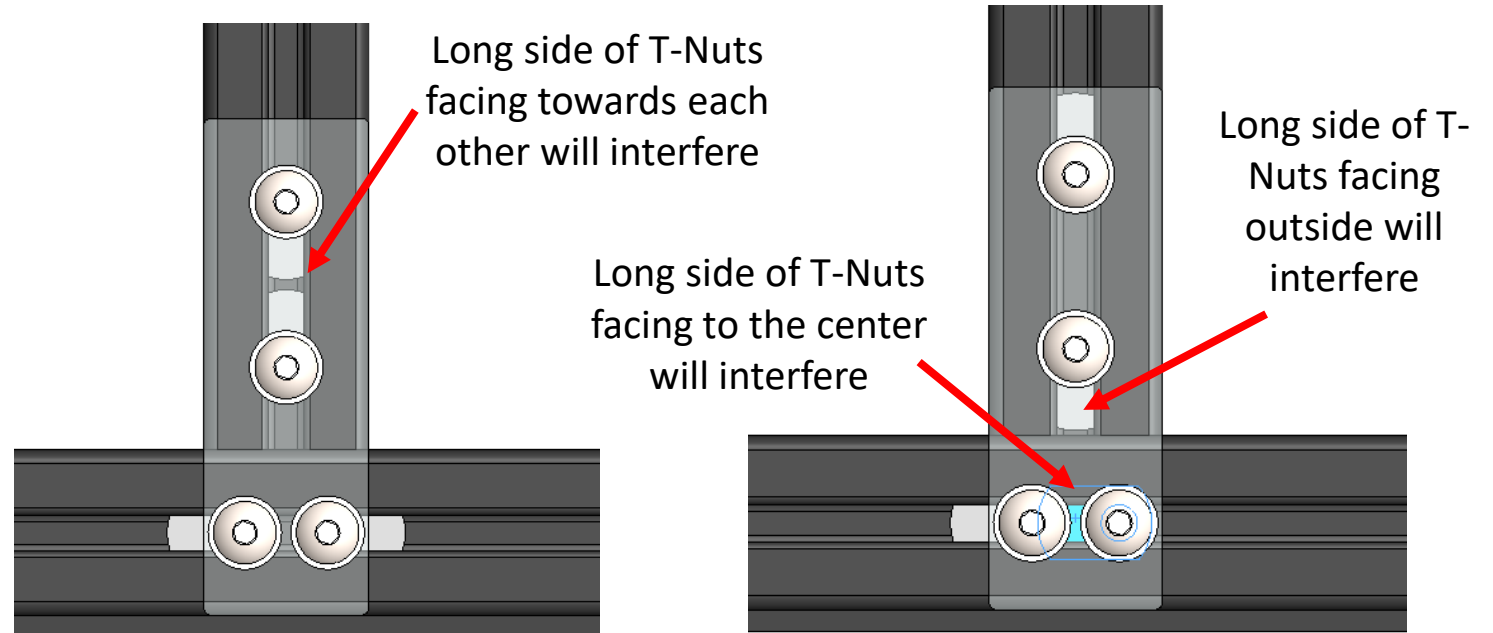

Long side of actual t-nuts is longer than shown in the image and will interfere

Unaka Narrow Cross Bar Brackets:

1. The Unaka narrow cross bar bracket was designed to reduce the amount of side rail space a bracket occupied while still providing a robust connection
2. Please note the orientation of the T-nuts.
3. **Incorrectly installed T-nuts will create interferences**
4. Note: Racks shipped late 4th quarter of 2023 and after will utilize a double t-nut at the side rail connection

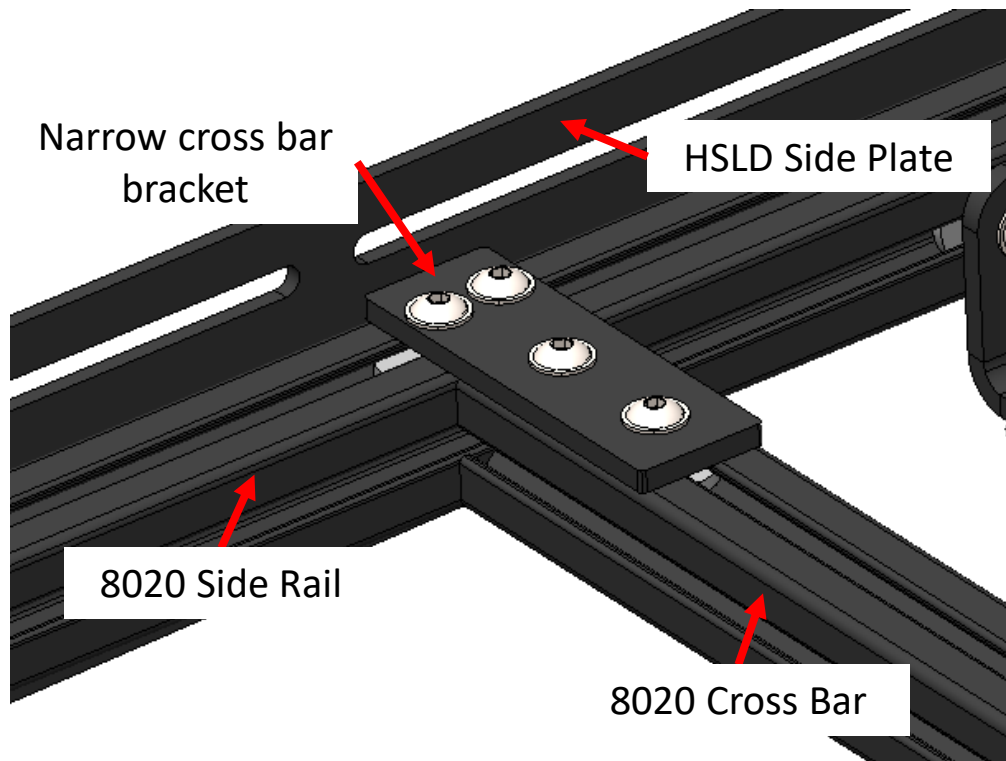

Correct way to Orient T-nuts
to prevent interferences

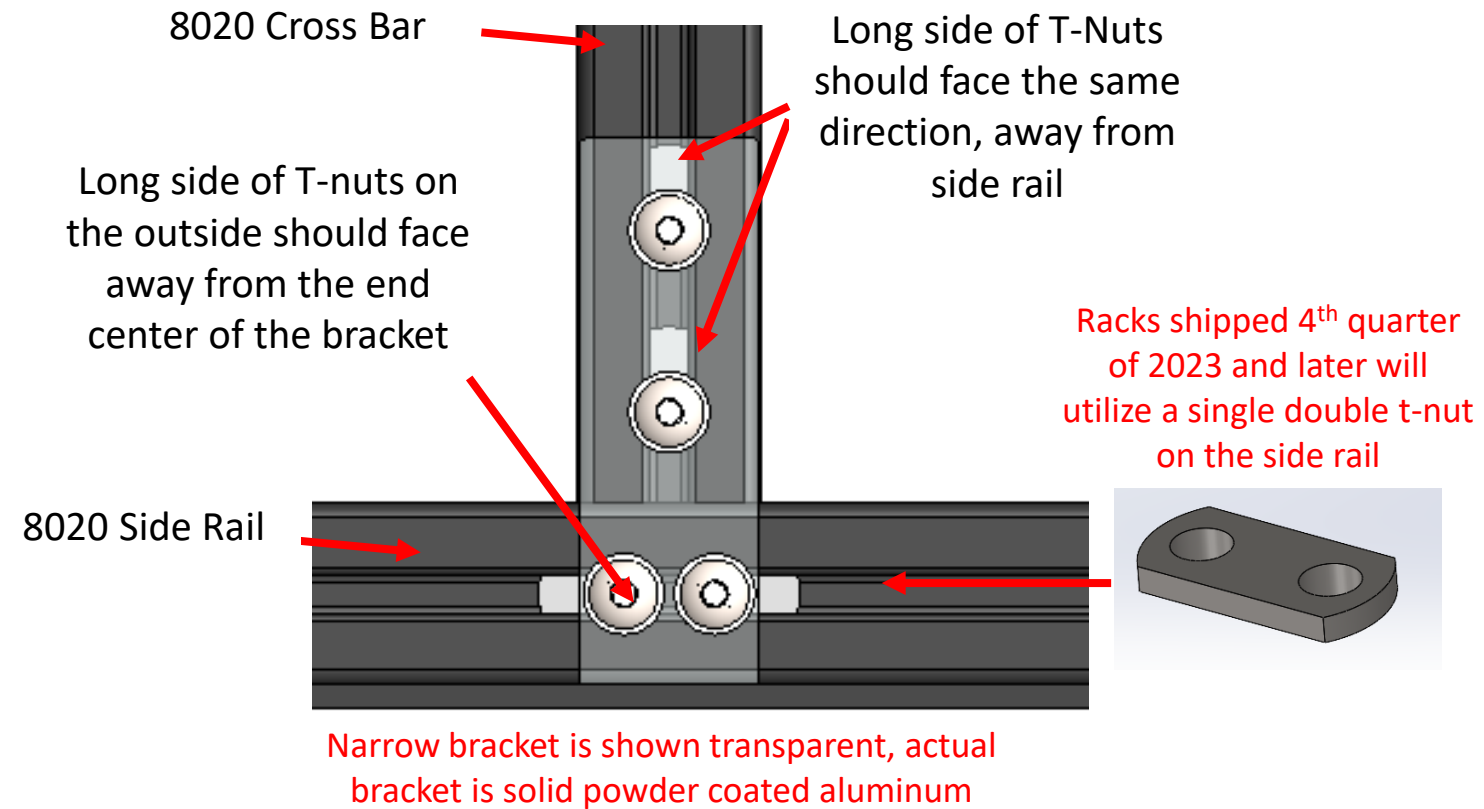

Unaka Narrow Cross Bar Brackets Continued

1. In some cases, the cross-bar position may need to be adjusted slightly to prevent the single t-nuts on the cross-bar brackets from interfering.
 - End Caps
 - Splice Plates
 - Other accessories
2. The single t-nut extends 0.33" from the side of the cross bar, so if an adjustment needs to be made it will be a small one
3. Note: Racks shipped late 4th quarter of 2023 and after will utilize a double t-nut at the side rail connection

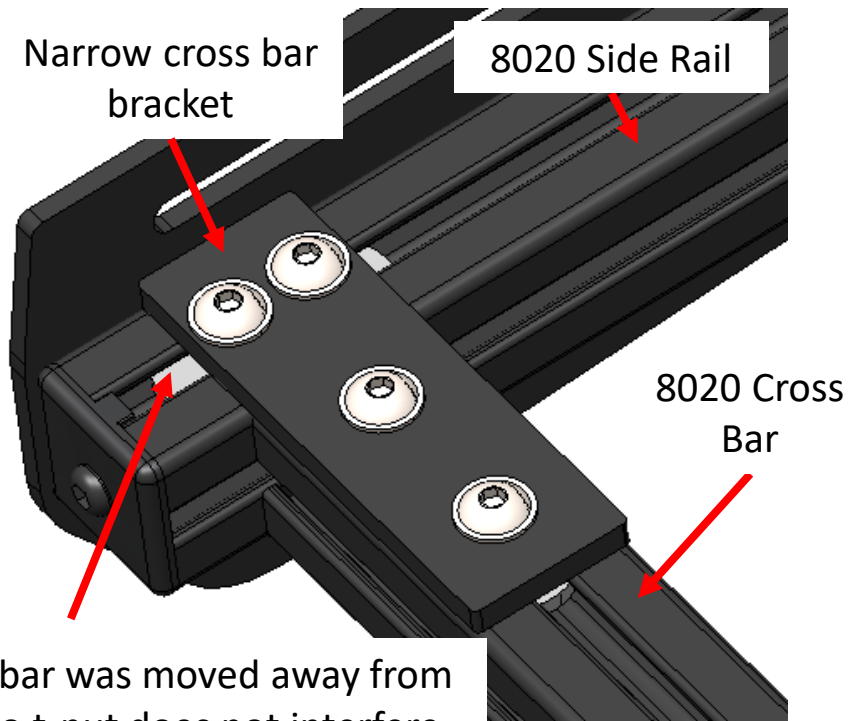

Cross bar was moved away from end so t-nut does not interfere with end cap or other items

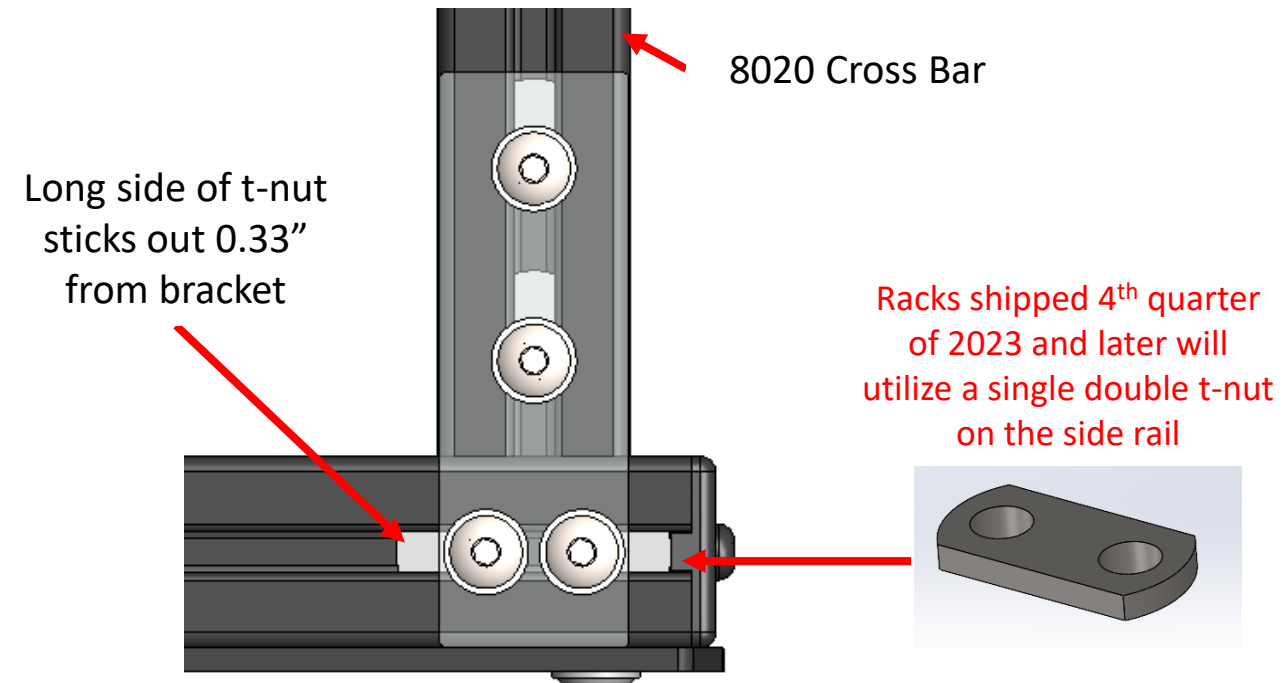

Narrow bracket is shown transparent, actual bracket is solid powder coated aluminum

170" WB Side Rail Assembly:

- This section covers the HSLD side rail assembly. Note the images shown are for the Driver side assembly. The passenger side assembly is a mirrored image.
- Below is the bill of material (BOM) for Qty 1 side rail assembly. These individual parts are found in the sub kits outlined shown on previous pages.
- The BOM for the driver side, and passenger side rail assemblies are identical and match the table below.

ITEM NO.	Manufacturer	PART NUMBER	DESCRIPTION	MATERIAL	QTY.
1	8020	203001-PLAIN	END CAP, 15 SERIES, PLAIN, BLACK	NA	1
2	8020	3267	SELF TAPPING END CAP SCREW, M7 X 0.36"	NA	1
3	Any	3607	BHCS, FLANGED, 5/16 X 0.687" LG., S.S., BLACK	NA	4
4	ANY	3678	T-NUT, ECONOMY, 5/16 THREAD, SS	NA	18
5	ANY	91831A030	LOCKNUT, 5/16-18, 18-8 S.S.	NA	4
6	ANY	92141A030	FLAT WASHER, 5/16" SCREW SIZE, 0.344" ID, 0.75" OD, 18-8 SS	NA	8
7	ANY	92949A582	BHCS, 5/16-18 X 1" LG, FULLY THREADED, 18-8 S.S.	NA	4
8	ANY	97525A490	RIVET, BLIND, 3/16" DIA, FOR MATL 0.126" - 0.25", 18-8 SS	NA	2
9	ANY	97654A304	BHCS, FLANGED, 5/16 X 0.625" LG., S.S.	NA	14
10	Unaka Gear Co.	1006-MB50-06 REV 0	SPRINTER HSLD SIDE RAIL SPLICE PLATE	5052-H32	2
11	UNAKA	1006-MA10-00	PROMASTER 80/20 ROOF RACK BRACKET ADAPTER	ASSEMBLY	5
12	Unaka Gear Co.	1005-MB01-01	STRAIGHT FLAT PLATE, 15 SERIES, 4 HOLE	6061 Alloy	1
13	Unaka Gear Co.	1006-MB50-01 REV 1	SPRINTER HSLD FRONT SIDE PLATE	5052-H32	1
14	Unaka Gear Co.	1006-MB50-02 REV 1	SPRINTER HSLD REAR SIDE PLATE	5052-H32	1
15	Unaka Gear Co.	1006-MB50-03 REV 0	SPRINTER 170 SPLICE SIDE PLATE	5052-H32	1
16	Unaka Gear Co.	1006-MB50-04 REV 0	UNAKA HSLD LOGO PLATE	AISI 304	1
17	Unaka Gear Co.	1515-UL-BLACK-75.875	8020 Style Extrusion, 15 Series, Ultra Lite, Grooved, Black, 75.875" LG.	6061 Alloy	1
18	Unaka Gear Co.	1515-UL-BLACK-91	8020 Style Extrusion, 15 Series, Ultra Lite, Grooved, Black, 91" LG.	6061 Alloy	1

170" WB Side Rail Assembly:

Driver Side HSLD Side Rail

REQUIRED TOOLS:

- MEASURING TAPE
- 3/16" ALLEN WRENCH
- BLUE LOCTITE 242

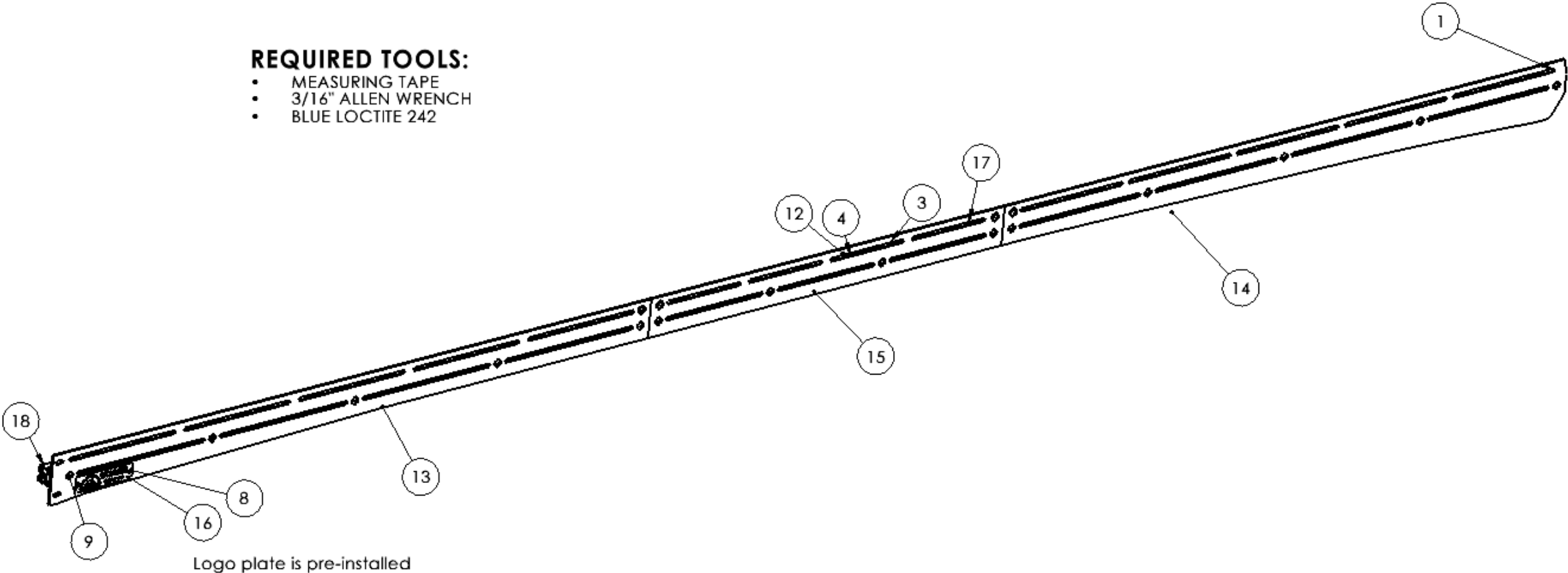

170" WB Side Rail Assembly:

Driver Side HSLD Side Rail

ASSEMBLY STEPS:

1. LAYOUT PARTS, ENSURE SIDE PLATE ITEMS (18), (14), (15) AND 8020 ADAPTER BRACKETS (11) ORIENTATIONS ARE CORRECT FOR THE SIDE RAIL YOU ARE ASSEMBLING
2. FOR PASSENGER SIDE RAIL ASSEMBLY, LAYOUT PARTS TO ENSURING YOU WILL BE CREATING AN OPPOSITE HAND VERSION TO THE DRIVER SIDE ASSEMBLY SHOWN BELOW.
3. DO NOT INSTALL END CAPS ITEM (1) AND (2) AT THIS TIME. THEY WILL BE INSTALLED AFTER ALL T-NUTS FOR THE CROSS BARS ARE INSTALLED
4. SPLICE PLATES ARE USED TO SECURE TWO SIDE PLATES TOGETHER. INSERT BOLT (7) THROUGH WASHER (6) THROUGH SIDE PLATE, THROUGH SPLICE PLATE (10), THROUGH WASHER (6), AND INTO NYLOCK NUT (5). THIS STEP IS REPEATED TWICE PER SPLICE PLATE. ***APPLY ANTISEIZE TO BOLT (7) DURING THIS STEP.

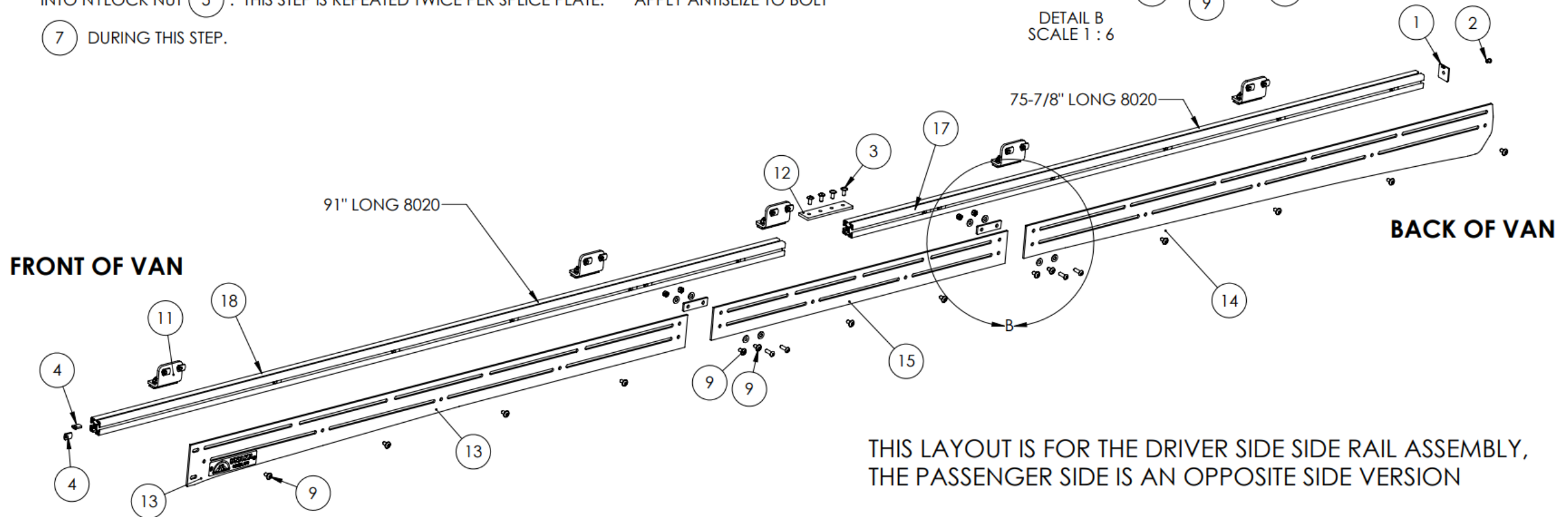

170" Side Rail Assembly:

Driver Side HSLD Side Rail

DRIVER SIDE RAIL ASSEMBLY

STEP 2 - 4: JOIN FRONT AND REAR 8020 WITH 4 HOLE SPLICE PLATE (12) APPLYING BLUE LOCTITE 242 TO BOLTS (3) BEFORE INSERTING

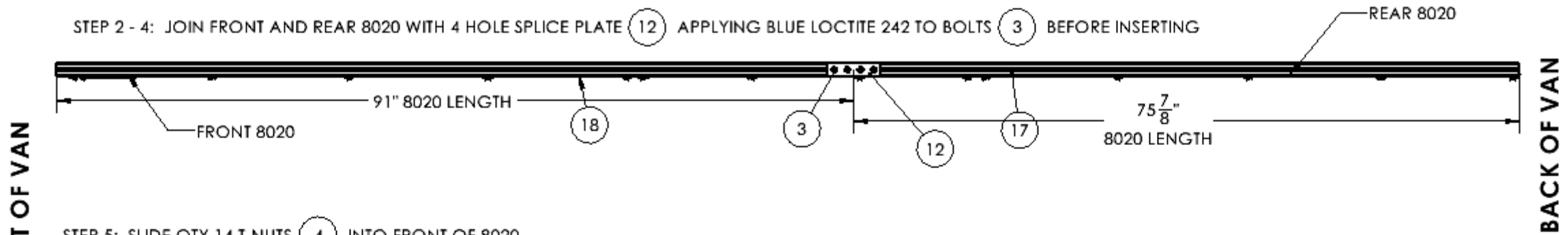

STEP 5: SLIDE QTY 14 T-NUTS (4) INTO FRONT OF 8020, POSITION BOLT HOLE TO DIMENSIONS BELOW

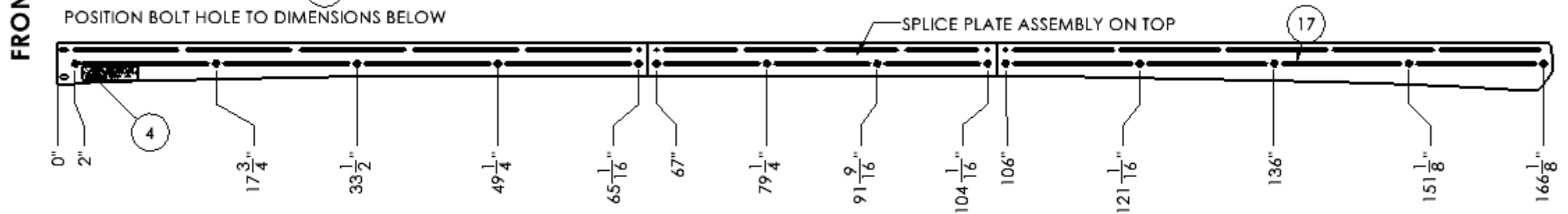

STEP 7: ALIGN FRONT SIDE PLATE (13) WITH FRONT OF 8020. APPLY LOCTITE TO SIDE OF FLANGE HEAD BOLTS (9), INSERT (9) THROUGH HOLES IN SIDE PLATE (13) AND INTO T-NUTS (4) WHICH WERE ROUGHLY POSITIONED ABOVE. REPEAT THIS PROCESS FOR SIDE PLATES (15) AND (14)

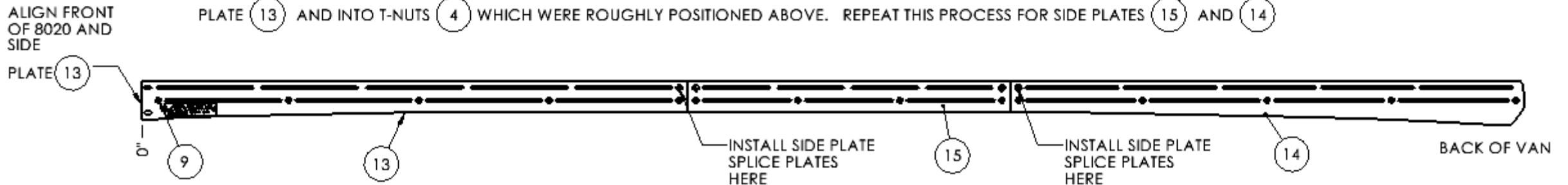

DRIVER SIDE RAIL ASSEMBLY

NOTE: THESE DIMENSIONS CALL OUT APPROXIMATE LOCATIONS FOR THE ROOF RACK BRACKETS WITH RESPECT TO THE SIDE RAILS. THESE CAN BE ADJUSTED FORWARD OR BACKWARD AS NEEDED DURING THE INSTALLATION, ESPECIALLY TO ACCOMODATE A CROSS BAR POSITION.

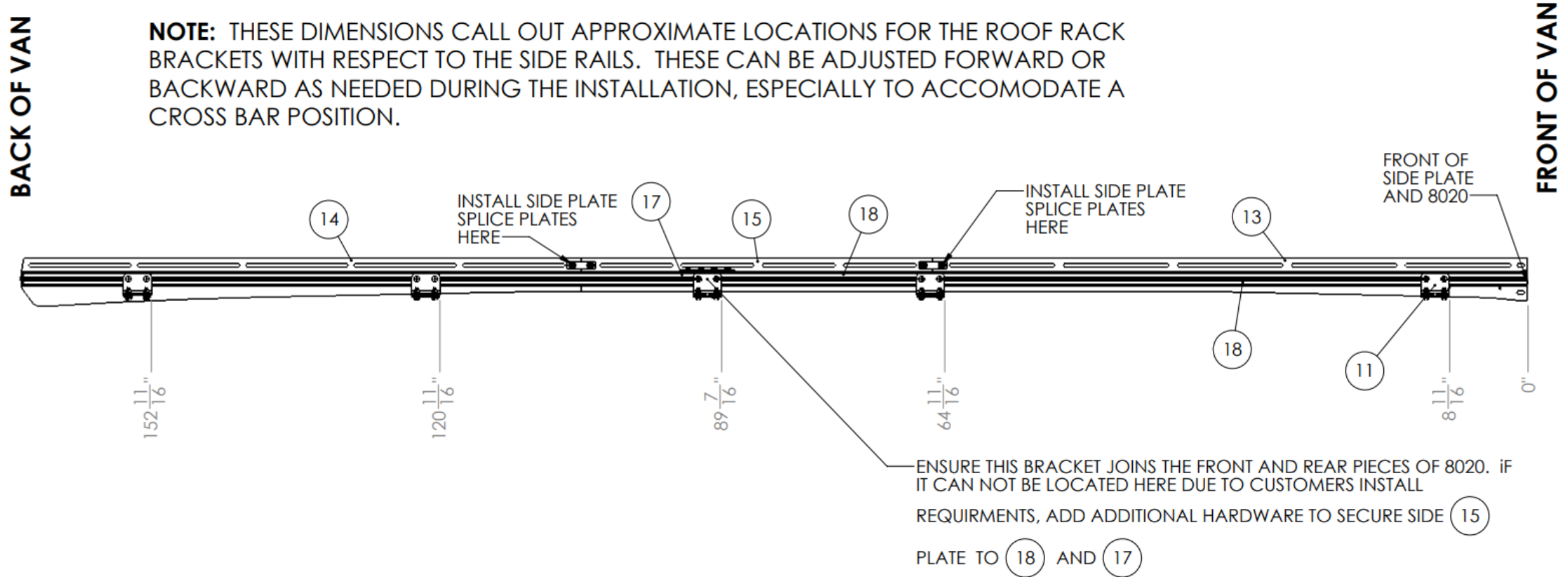

Cross Bar Initial Assembly:

ITEM NO.	Manufacturer	PART NUMBER	DESCRIPTION	MATERIAL	QTY.
1	Unaka Gear Co.	1515-UL-BLACK-53.75	8020 Style Extrusion, 15 Series, Ultra Lite, Grooved, Black, 53.75" LG.	6061 Alloy	1
2	Any	3607	BHCS, FLANGED, 5/16 X 0.687" LG., S.S., BLACK	NA	8
3	ANY	3678	T-NUT, ECONOMY, 5/16 THREAD, SS	NA	4
4	Unaka Gear Co.	1005-MB03-01 REV 0	STRAIGHT FLAT PLATE, 15 SERIES, 4 HOLE	6061 Alloy	2
5	Unaka Gear Co.	1005-MP00-01 REV 0	DOUBLE T-NUT, 15 SERIES, ECONOMY, 5/16-18 THREAD, SS	AISI 304	2

REQUIRED TOOLS:

- 3/16" ALLEN WRENCH
- BLUE LOCTITE 242

ASSEMBLY STEPS:

1. SLIDE ANY T-NUTS INTO TOP OF 8020 REQUIRED FOR FLUSH MOUNT SOLAR PANEL BRACKETS OR OTHER ACCESSORIES. NOTE THESE ADDITIONAL T-NUTS ARE NOT PROVIDED WITH THIS CROSS BAR ASSEMBLY
2. SLIDE QTY 2 ITEM (3) INTO TOP OF BOTH ENDS OF 8020, APPLY BLUE LOCTITE 242 TO SIDE OF BOLT (2), USE BOLT TO SECURE THE NARROW BRACKETS (4) TO TOP OF 8020. SNUG BOLTS UP ONLY IN CASE BRACKET NEEDS TO BE ADJUSTED WHEN INSTALLED ON VAN RACK
3. REMAINING QTY 4 OF BHCS AND T-NUTS WILL BE USED TO SECURE THIS CROSS BAR TO THE RACK SIDE RAIL ASSEMBLY ON THE ROOF OF THE VAN
4. WHEN SECURING CROSS BAR TO 8020 SIDE RAIL ON ROOF OF VAN, PLACE BLUE LOCTITE 242 ON SIDE OF BOLT BEFORE INSERTING IT THROUGH BRACKET AND INTO T-NUT

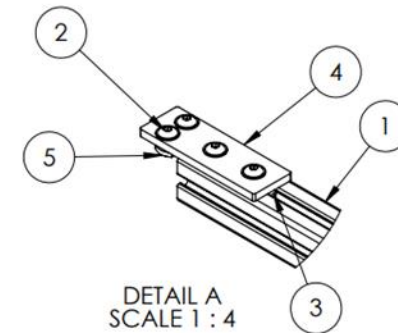
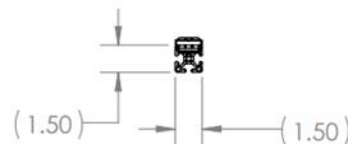
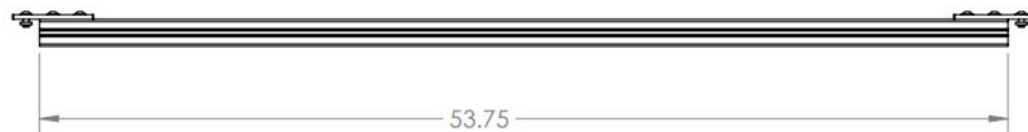
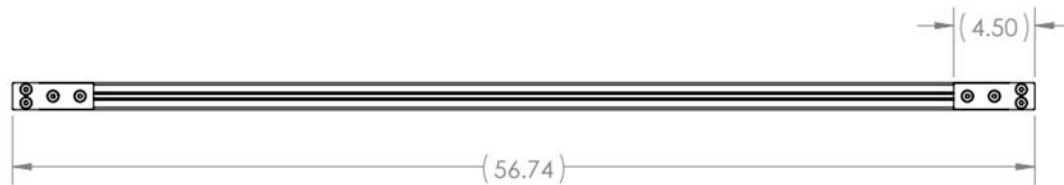
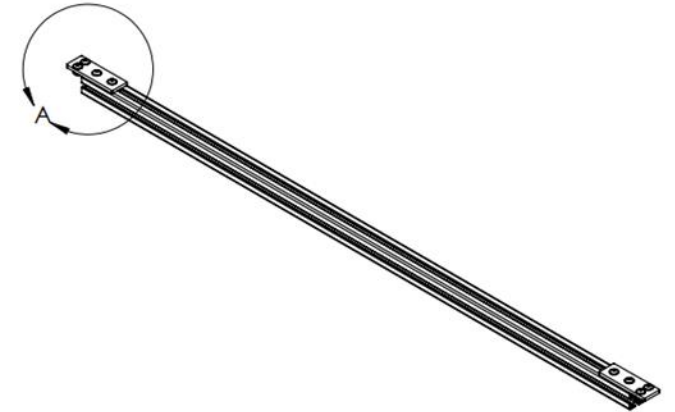

Cross Bar Initial Assembly:

1. If you haven't done so, double check to see if any other parts in future steps will need to be attached to your cross bars and how many t-nuts will be required for each item. This includes flush mount solar panel brackets, other 8020 brackets, the tie downs, etc.
2. Install the brackets required to secure your cross bar to the side rails. The Unaka standard option is the flat narrow 4 hole brackets which each use 4 bolts and t-nuts. Other options include using cross bars that use 4 x 2 hole corner brackets, 5 hole L brackets, or your own custom solution.
3. Do not fully tighten the hardware at this time. Leave at least one or two pieces of hardware tight enough where the brackets won't come loose and slide off the end of the extrusion while lifting and lower the cross bars into place.
4. If cross bar assemblies include different quantities of hardware for different accessories, mark them so that they get installed in the correct order or location on the roof rack

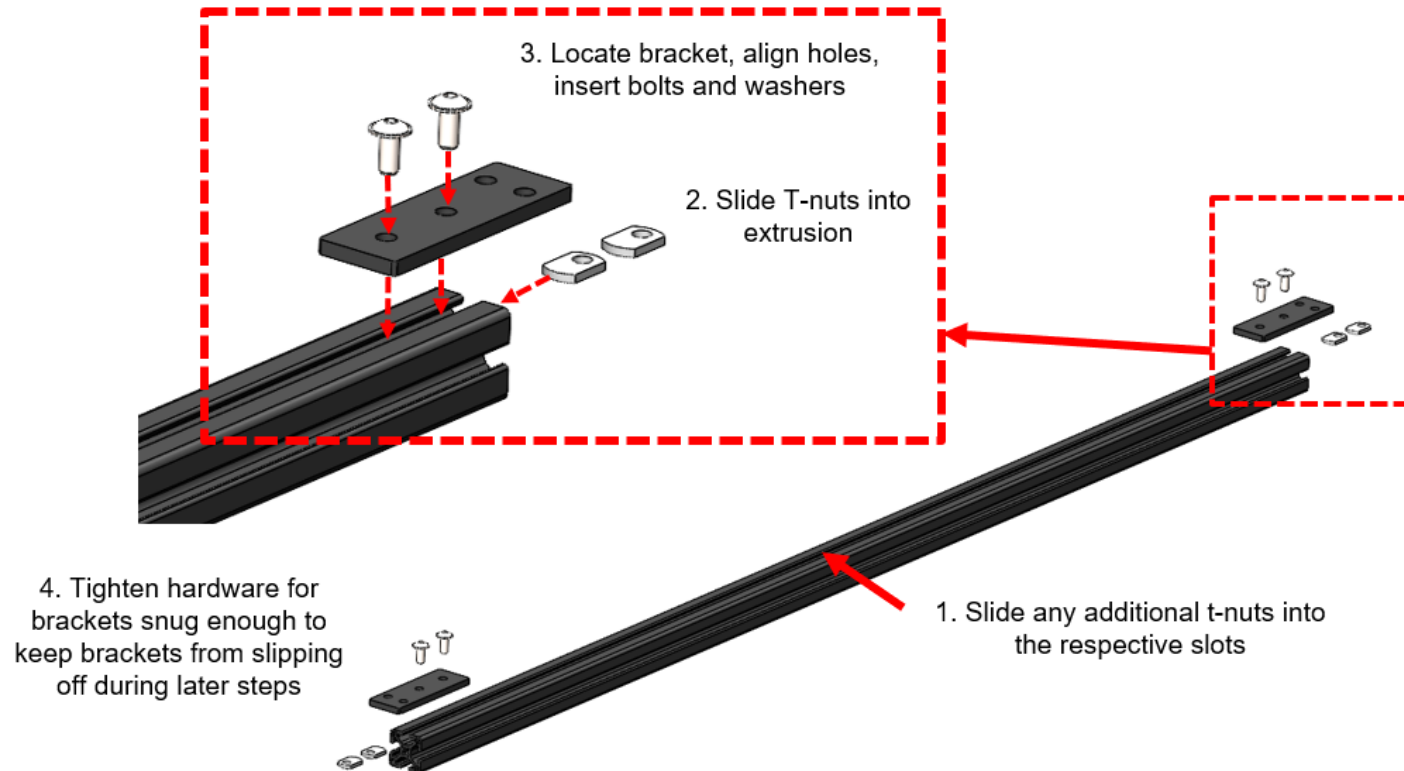

Assemble Wind Fairing End Caps

1. Apply anti-seize to all bolts in this step during installation
2. Warning: Top and bottom end cap brackets look very similar, but they have identifying notches. Lower bracket has 1 notch, upper bracket has no notches.
3. End cap brackets should be installed with the tab with the chamfered corners bolting to wind fairing end cap
4. Bolt top and bottom wind fairing brackets to driver side end cap. ***Leave the bolts just loose enough so the brackets can float around in their slots
5. Repeat process for passenger side end cap

Driver Side End Cap Assembled

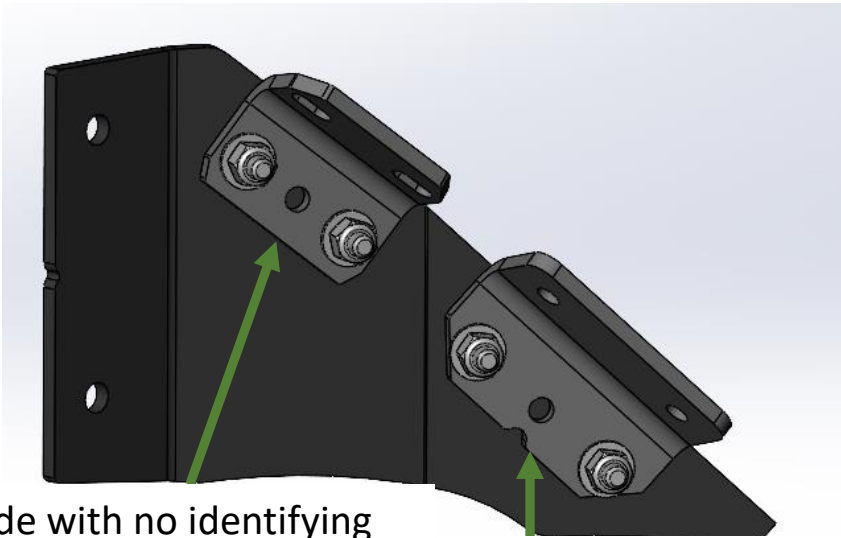

Side with no identifying notches bolts to end cap 1 Identifying notches

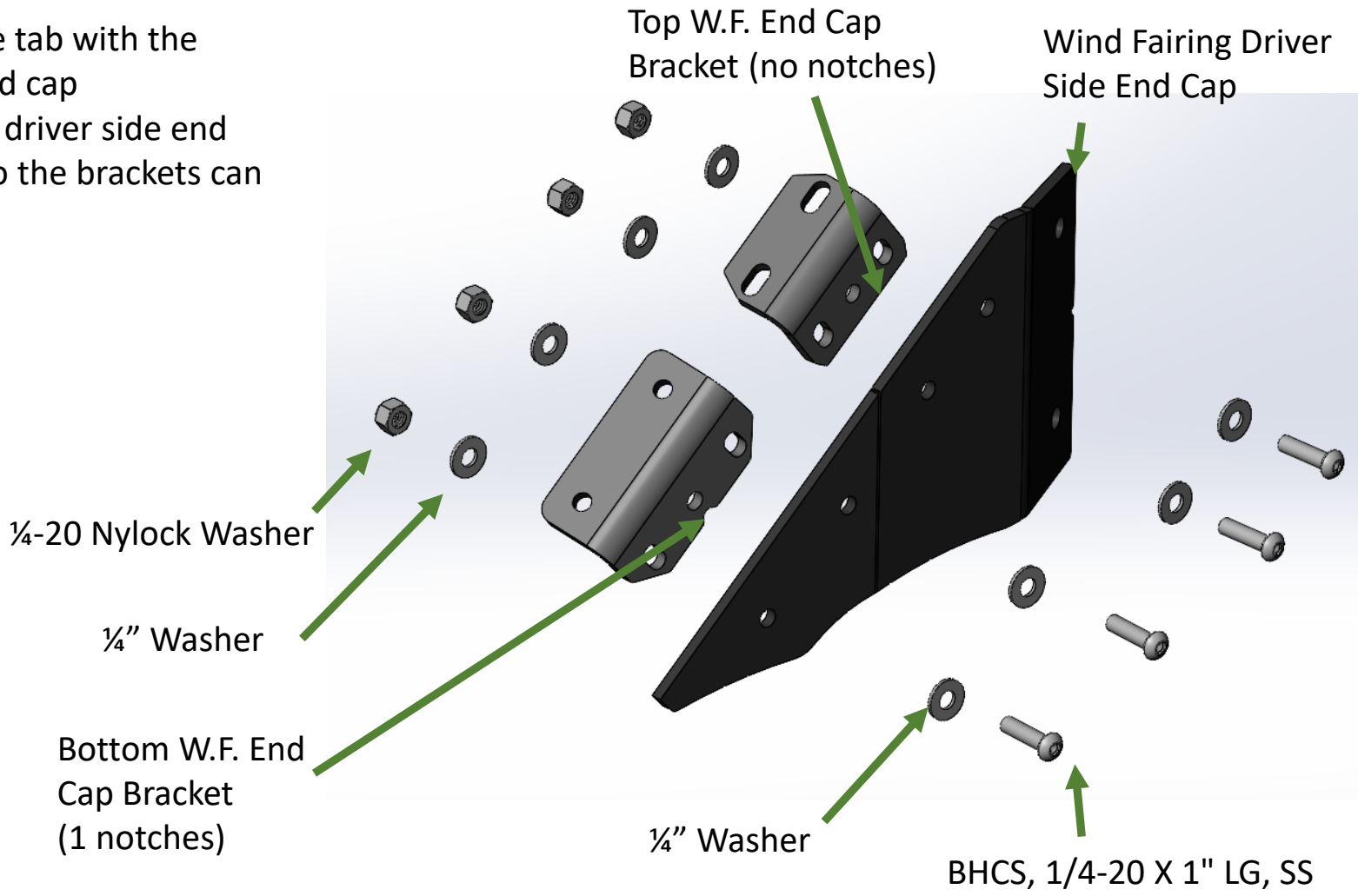

Bolt wind fairing to end caps

1. Apply anti-seize to all bolts in this step during installation
2. Hardware holding end cap brackets to the end cap still slightly loose
3. Loosely bolt the wind fairing to the wind fairing end cap assemblies
4. ****Tighten the hardware carefully. Do not tighten hardware one at a time. Holding / position the wind fairing to align the edges of the fairing with the end cap as best you can. All edges may not be perfectly aligned due to manufacturing tolerances. Move between the bolts tightening them each a bit slowly until everything is nice and tight. If you tighten one bracket to much, it may not allow the adjustment slots in the brackets to compensate for manufacturing and installation tolerances**
5. Repeat for the passenger side end cap
6. Install the bulb seal on the front edge of the wind fairing

Completed passenger side end cap / wind fairing

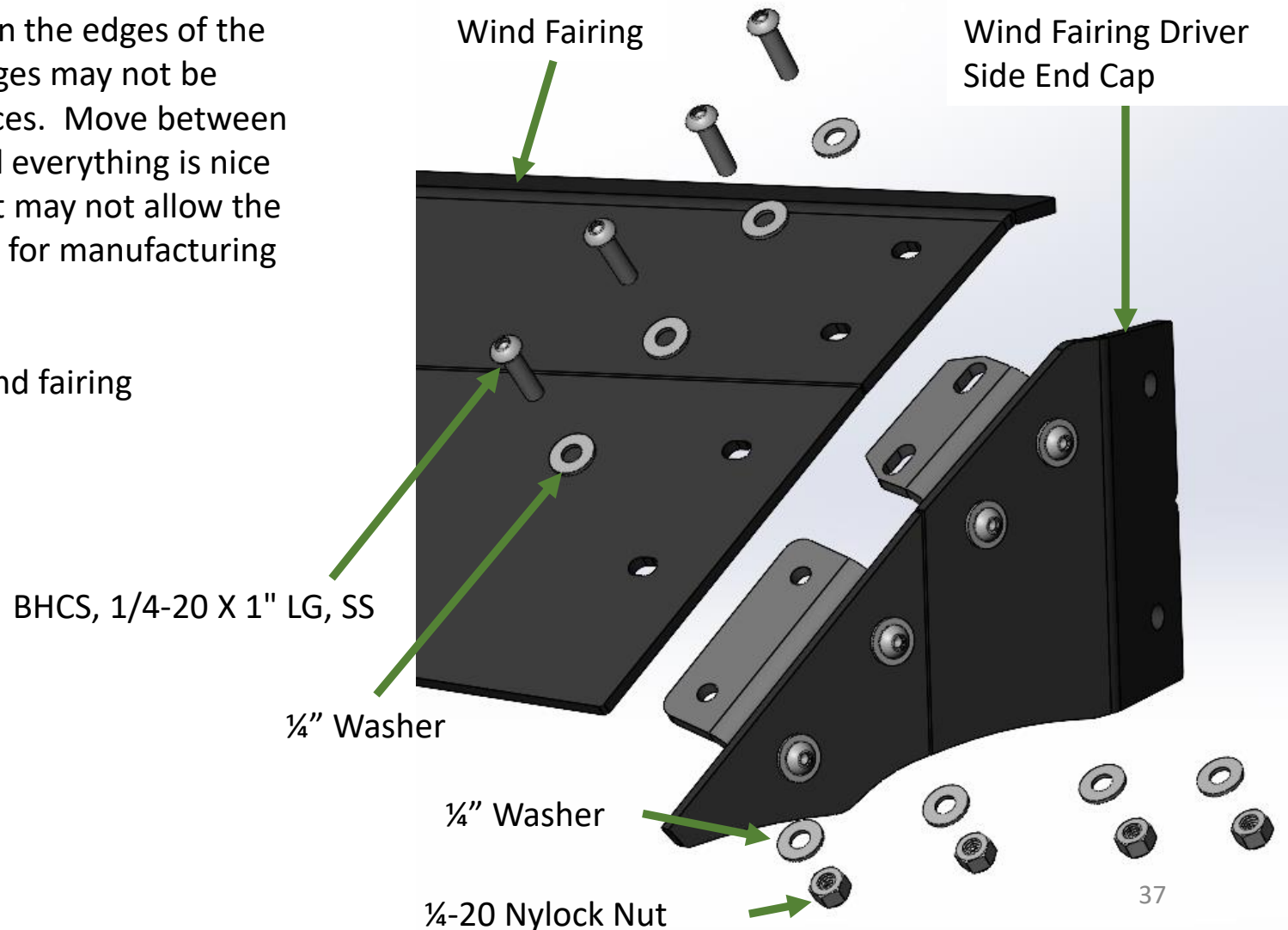
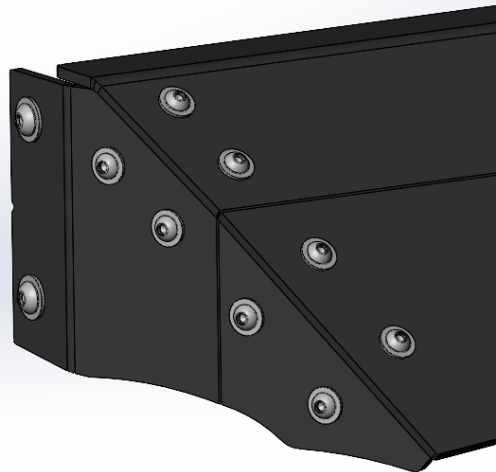

Install Washer Plates & Loosely Install Side Rails

1. Each side of the van gets the following brackets:
 - a) 144" WB: 4 bracket assemblies per side
 - b) 170" WB: 5 bracket assemblies per side
 - c) 170" WB EXT: 6 bracket assemblies per side
2. Insert carriage bolts into washer plates, slide all washer plate assemblies roughly into place in the factory roof channels

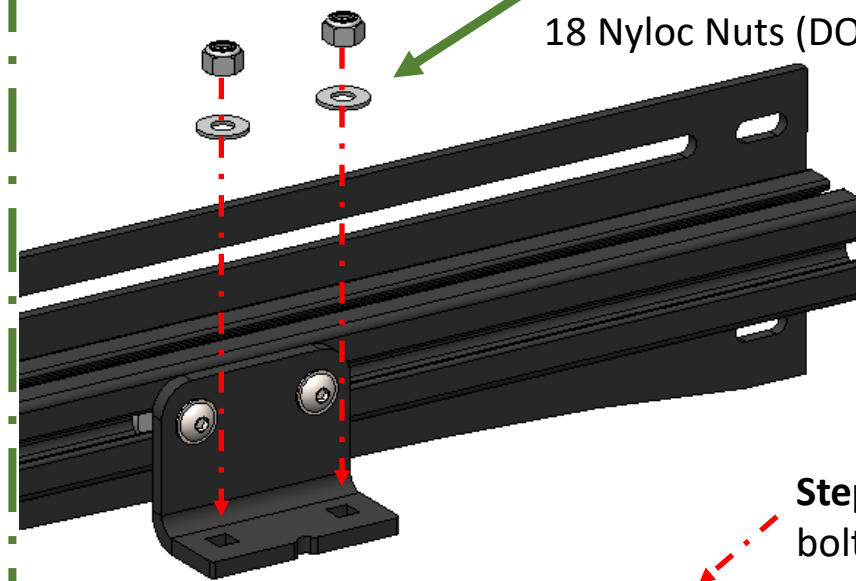

Step 4: Apply Loctite to side of carriage bolts, then slide 5/16" washer onto bolts, and loosely start the 5/16-18 Nyloc Nuts (DO NOT tighten yet)

Step 3: Lower side rail assembly down onto carriage bolt / washer plate assemblies

Step 1: Insert carriage bolts into washer plates

Step 2: Slide all carriage bolts / washer plate assemblies into factory roof rails and roughly position to where they will be used

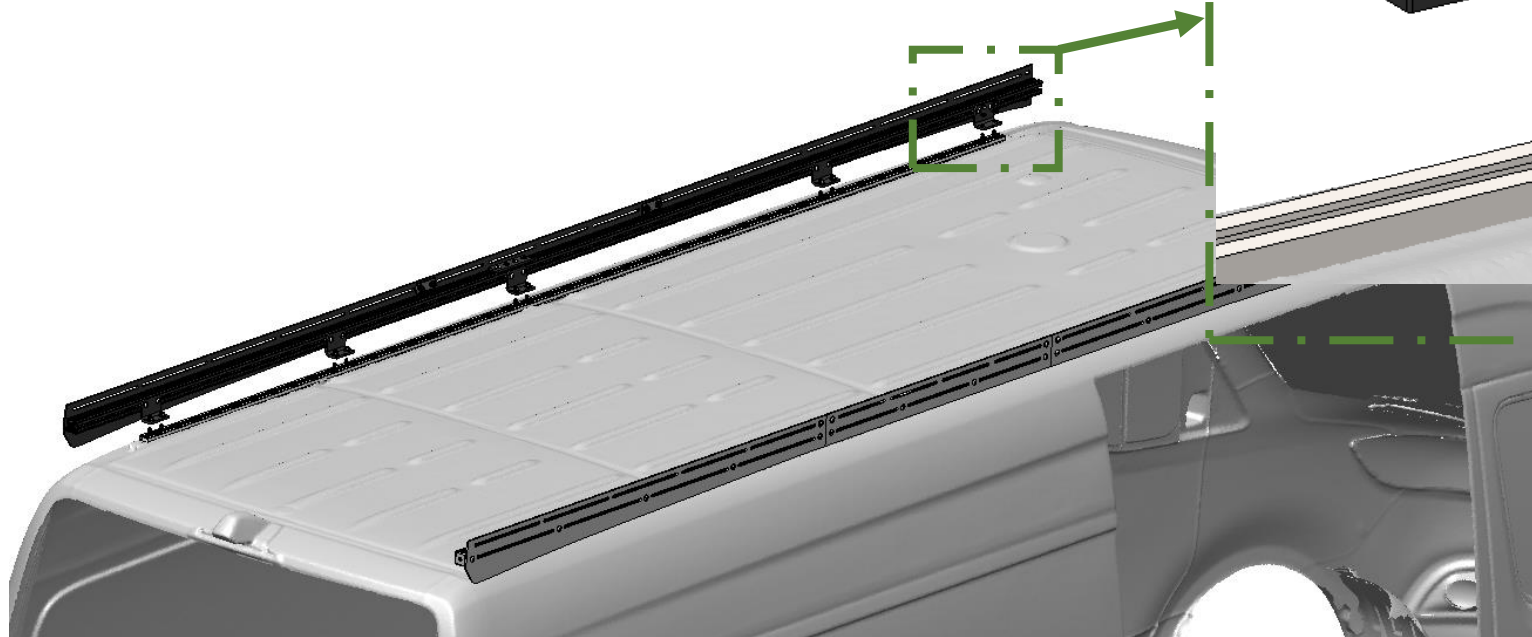

*Image shows a Sprinter 170" WB

Loosely Install Side Rail Assemblies

1. Install 1 side rail assembly at a time using 2 people
2. Hold side rail assembly next to rail, slide washer plates so they very closely line up with brackets on side rail assembly
3. Lower side rail assembly over washer plate assemblies (move side rail forward / backward as needed to get the bolts into the brackets)
4. Apply Loctite to carriage bolts, install washers and nylock nuts. Only loosely tighten so that entire assembly can still move forward and backwards on the factory roof channel. **DO NOT Fully Tighten.**

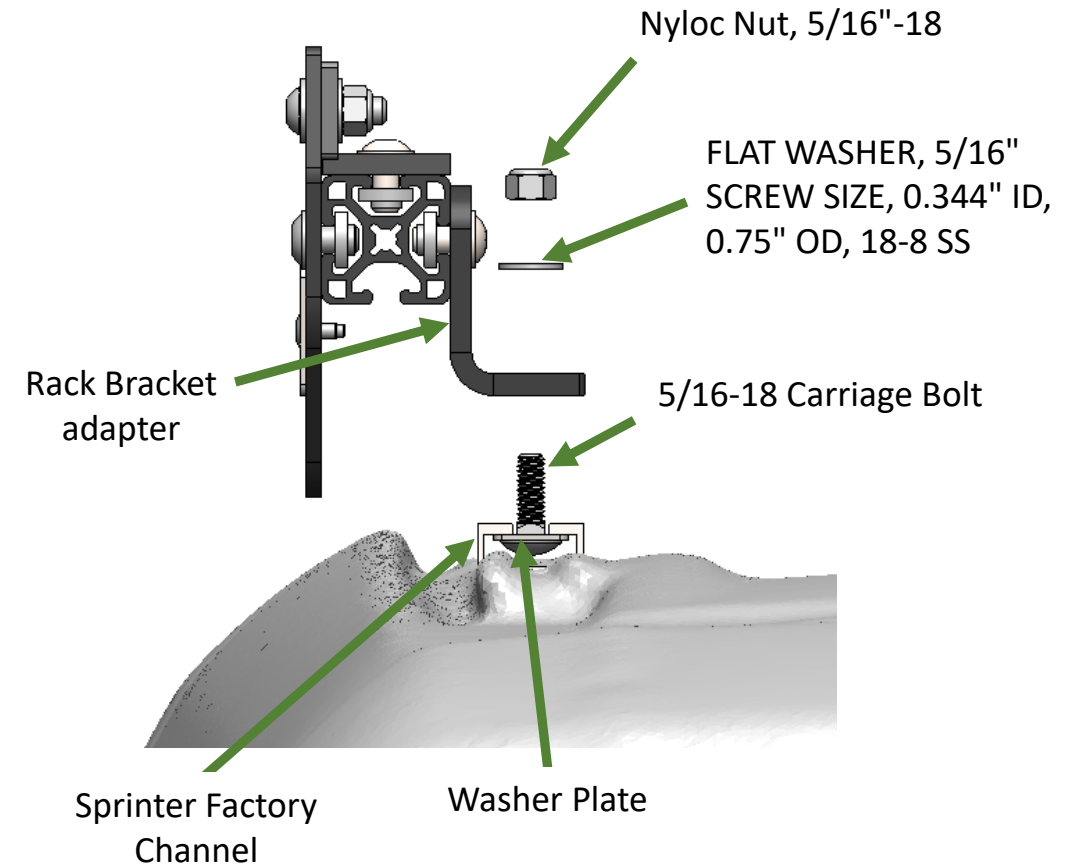

Sprinter Roof Reference

1. All Sprinters have a generic identification point at the back center of the roof just in front of the back up camera
2. This point can be used to reference dimensions during or post installation
3. When required, measure from the center of this identification circle

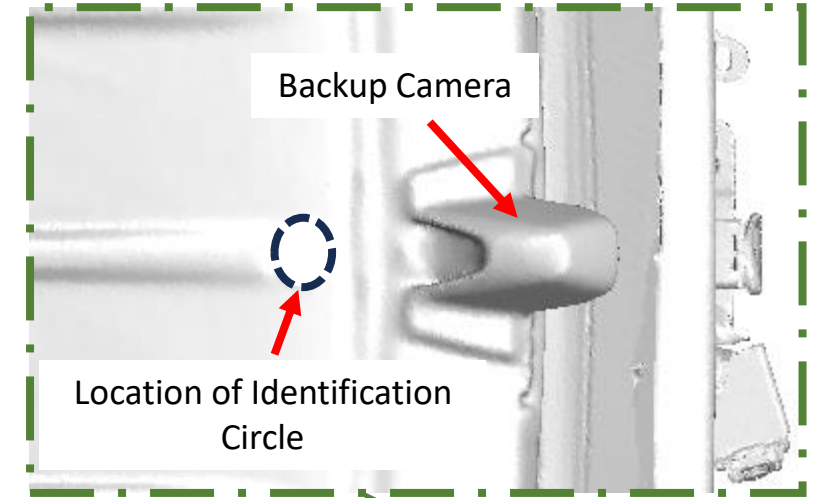
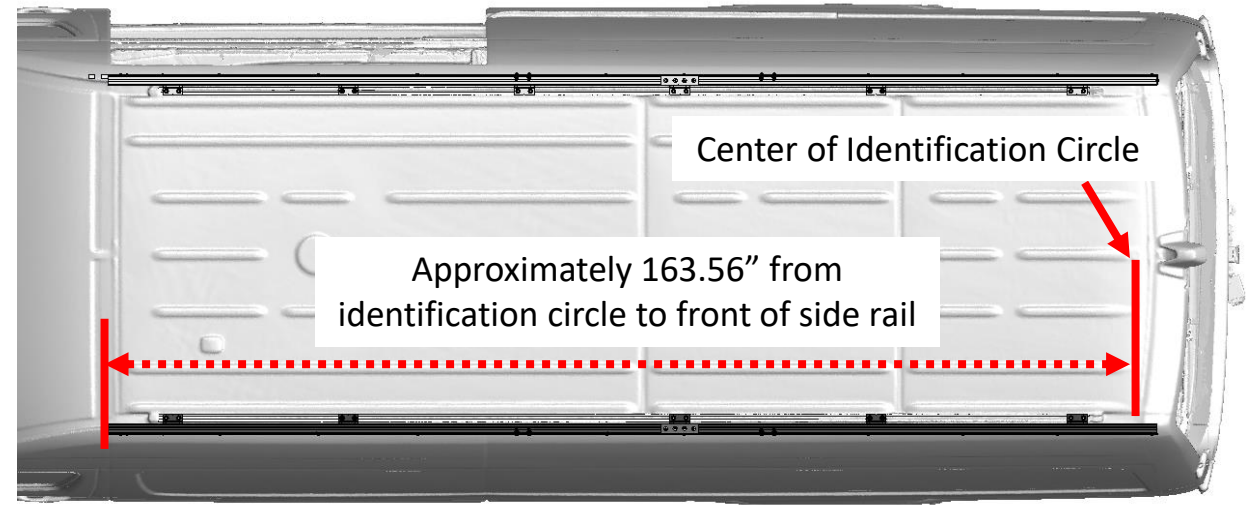

*Image shows a Sprinter 170" WB

Position Side Rail Assemblies

1. The HSLD side rails & wind fairing were designed to fit a specific spot on the roof of your van, but variations in factory installed components on the van, aftermarket rails, or customers requirements may require the position of the side rails and wind fairing to be adjusted during installation.
2. Once the side rails are on the brackets, slide them forward so that the 8020 adapter is all the way at the front of the factory track
3. This should position the front of your side rail at 8-11/16" in front of the factory rack or 163.56" from the van reference point
4. Note, this is a target dimension, once the wind fairing is installed, it can be adjusted as desired or needed.

Note: If you find that the dimensions above are not optimal for your installation we would love to hear your feedback. Email us a CSR@unakagearco.com with your van / rack size, your dimensions, feedback, and a few pictures so that we can optimize this dimension in the manual for future users.



Position the front of each side rail assembly so that it is 8-11/16" in front of the leading edge of the 8020 adapter which should be slide all the way forward in the factory tracks.

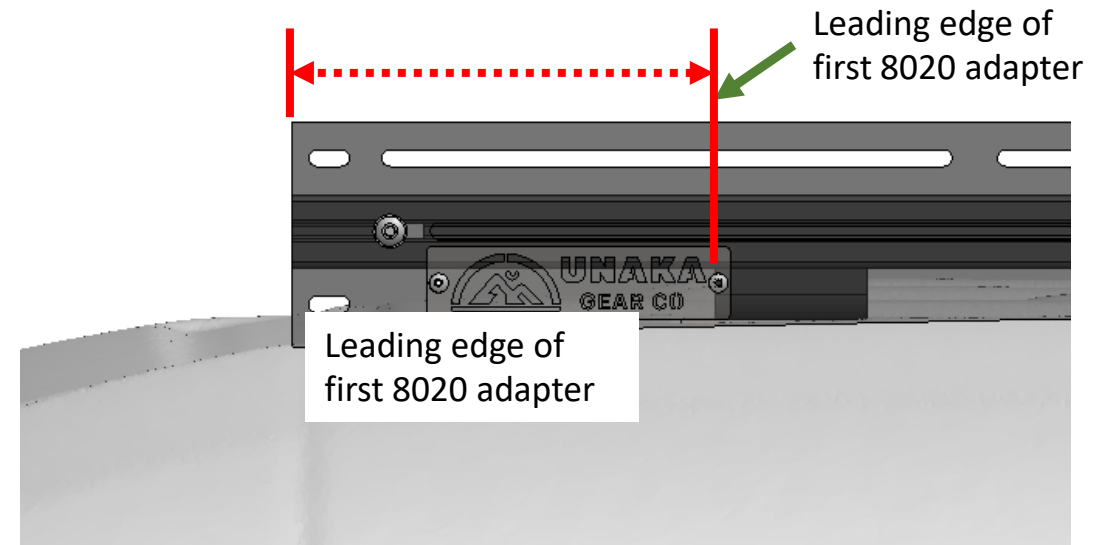

Loosely Install Cross Bar Assemblies

1. Rough position your cross bars to set the rail to rail spacing. In order to set the side rail to rail spacing in a later step, you will need at least one towards the front, one towards the middle, and one towards the back even if you move them based on your design needs later.
2. Slide 2 t-nuts or 1 double t-nut into the top of each side rail assembly for each cross bar bracket.
3. Some of these t-nuts will need to be installed from the front, and others from the back. Unless you remove the splice plate you will not be able to install all t-nuts from the front or back.
4. Now is also a good time to add any additional t-nuts into the top of your 8020 side rails that you may need for other accessories (awnings, etc.). Even if you get them close and have to remove one cross bar bracket to re-position them bolts past it, at least you won't have to remove all of them.
5. In some cases, your 4 hole splice plate may interfere with your desired cross bar location. If this is the case, slide the 4 hole splice plate to one side, or just use the 4 hole cross bar bracket as the splice plate.
6. Note, your 8020 rack adapters and cross bars may also interfere from time to time. If your cross bar can not be moved, just re-position the roof rack bracket forward or backward as needed.
7. Lower your cross bars onto the 8020 side rails
8. Apply Blue Loctite 242 to the sides of the hardware provided with the cross bar assemblies, and thread them into the installed t-nuts. Do not fully tighten.



For every cross bar, slide 2 t-nuts into the top of each 8020 side rail. If cross bars are located in front of the 4 hole splice plate, insert those t-nuts from the front

*Image shows a
Sprinter 170" WB

Potential Interference / Adjustments

- In some cases, your 4 hole splice plate may interfere with your desired cross bar location. If this is the case, slide the 4 hole splice plate to one side, or just use the 4 hole cross bar bracket as the splice plate.

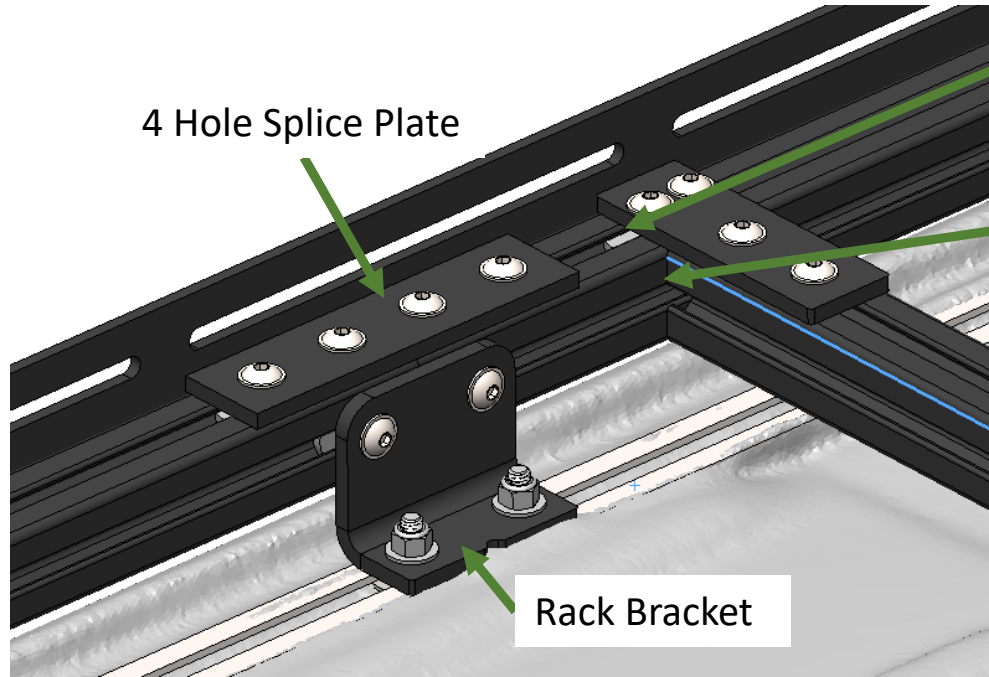

- Cross Bar Plate would interfere with 4 hole splice plate.
- Cross bar butts up against 8020 side rail, so it can not occupy the same location as the rack bracket

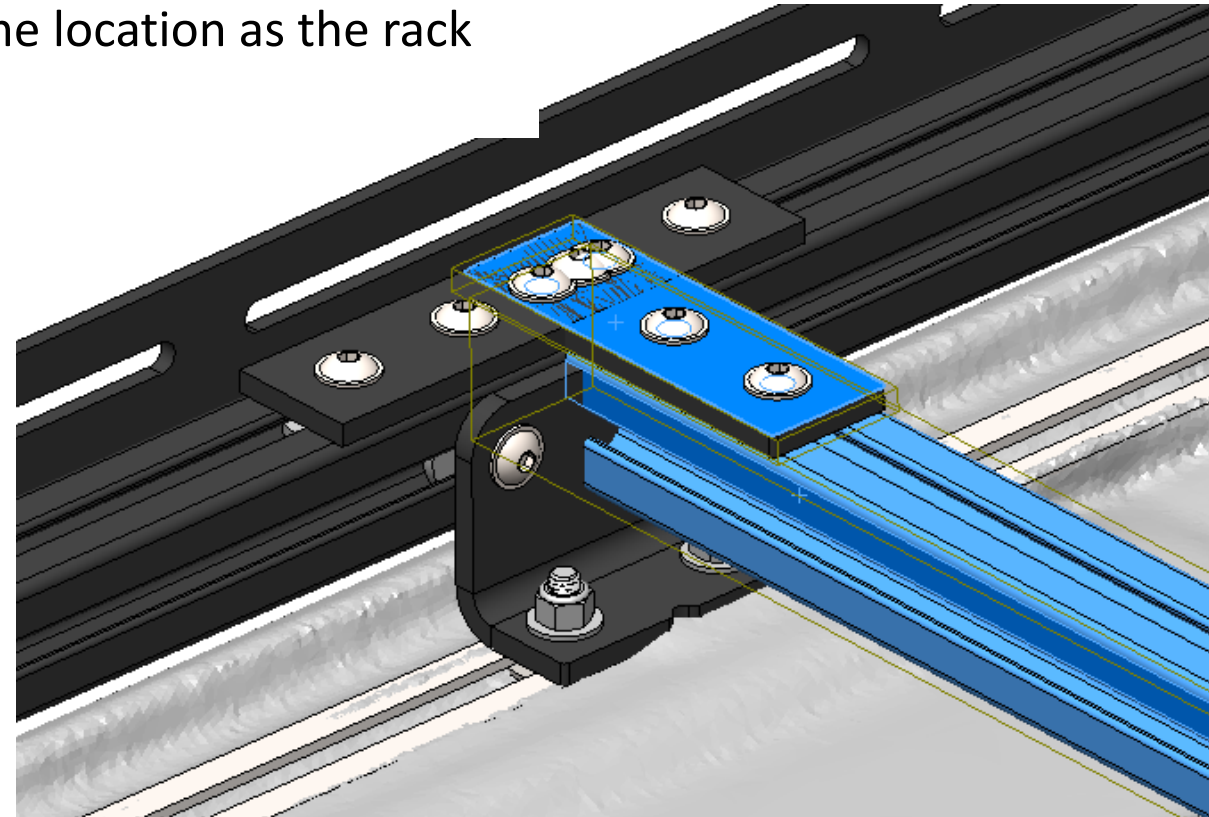

Potential Interference / Adjustments

Solutions to splice plate interference

Side rack bracket and splice plate forward or backwards, trying to leave at least 1 bolt engaged on both pieces of 8020 to keep that splice strong

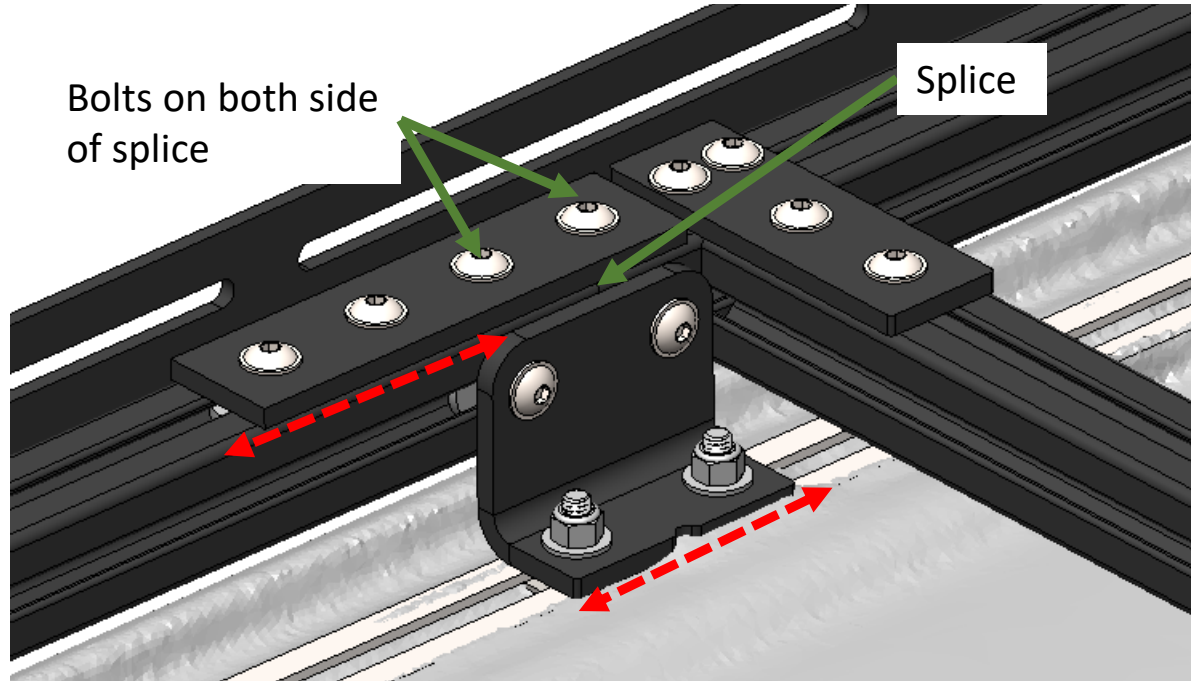

Or slide splice plate and bracket out of position, and let the cross-bar bracket rest at the 8020 splice

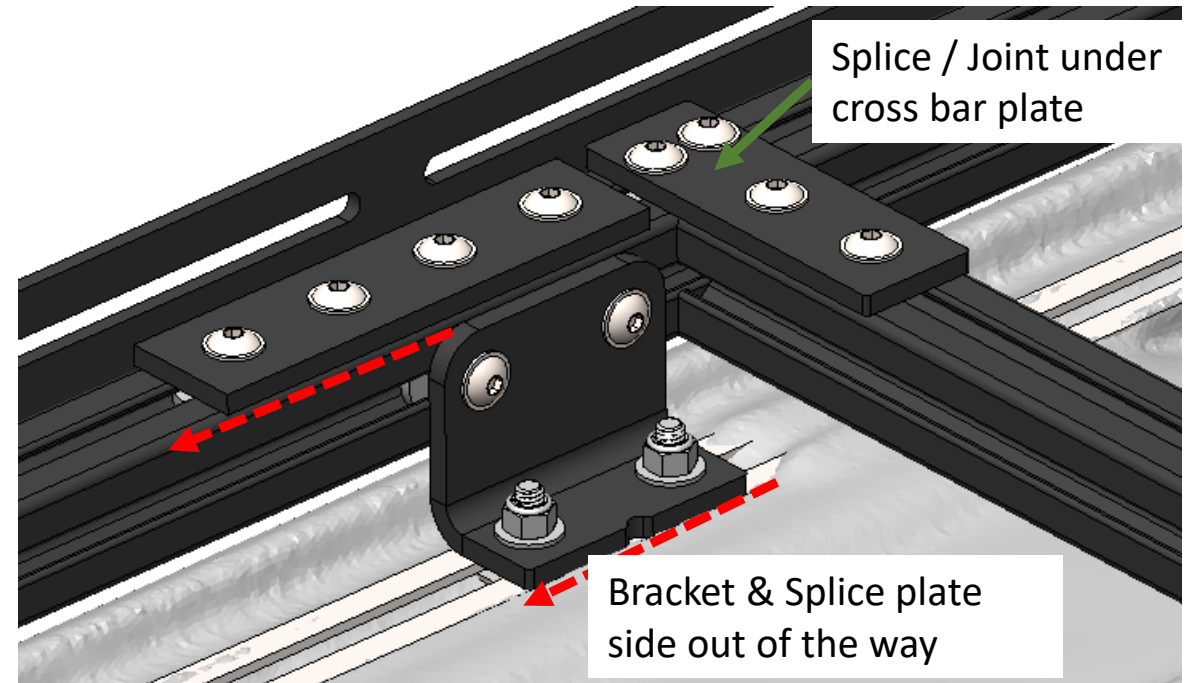

Potential Interference / Adjustments

- Note, your 8020 rack adapters and cross bars may also interfere from time to time. If your cross bar can not be moved, just re-position the roof rack bracket forward or backward as needed.

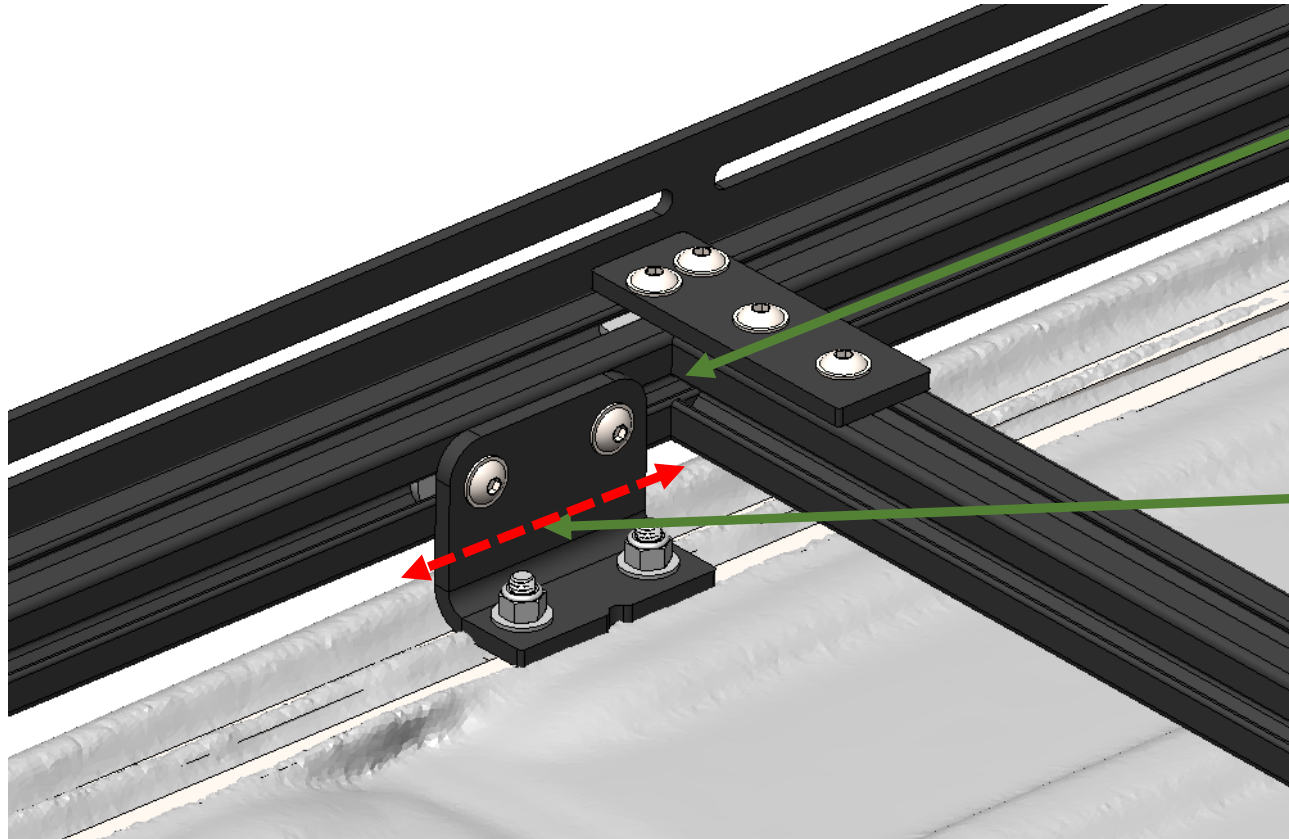

Cross bar butts up against 8020 side rail, so it can not occupy the same location as the rack bracket

Options:

1. Reposition cross bar
2. Slide rack bracket forward or backwards to eliminate interference

Loosely Install Wind Fairing Assembly

This step should be completed with 2 people using 2 ladders

Tip: Use rags as needed to protect the van if you need to sit the wind fairing on the van roof

Warning: Take extra precautions to not drop the wind fairing onto the wind shield, and down the front of the van

Note: The slots in the side plate allow for forward / backward adjustment of the wind fairing, as well as gives the ability to adjust the angle of the wind fairing

1. Install rubber bulb seal onto the leading edge of the wind fairing assembly
2. Lower the wind fairing assembly down so it is on the outside of the side plates
3. Insert the 5/16-18 x 1" long BHCS through the 5/16" washer, apply anti-seize to the side of the bolt, insert through the side plate, through the 2nd 5/16" washer, and into the nylock nut. Use a 3/16" allen wrench and a 1/2" socket wrench to tighten, do not fully tighten.
4. Repeat for other bolts
5. Use the slots in the side rail assembly to position the wind fairing as desired and snug up hardware
6. Confirm that both side rails are the same distance from the end of the factory rack track.
7. Confirm wind fairing and side rail assembly achieve desired fit and look
8. Tighten all hardware attaching wind fairing to side rail assemblies

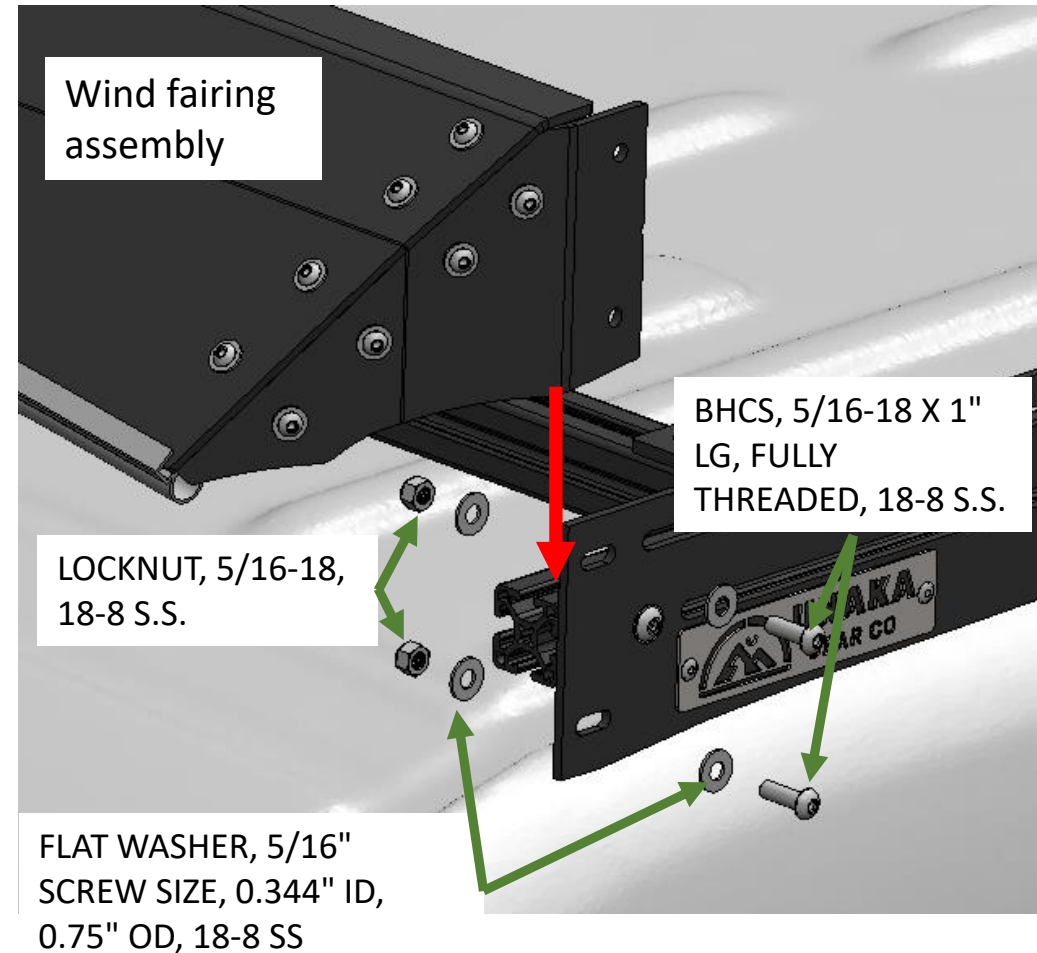

Set side rail to side rail spacing

This step should be completed with 2 people using 2 ladders

1. Position 3 to 4 of the installed cross bars along the length of the rack
 - a) At a minimum place one towards the front, one towards the middle, and one towards the back
 - b) Do not place cross bars directly over a rack bracket
2. Loosely bolt the cross bars to the 8020 rails
3. Once the cross bars are in place, center the rack on the van and set the side rail to side rail spacing so that the cross bars are tight, but can still be removed, or adjusted forward or backwards. As you adjust, the rail to rail spacing, snug up the roof rack brackets and cross bar hardware
 - a) If the rack brackets are too tight, loosen them just enough to allow the rail to rail spacing to be set
4. Once everything is parallel and even with each other, tighten the rack brackets to the van roof.
5. Double check that all rack brackets are tight before moving to the next step. Once solar panels and other items are installed, tightening and checking this hardware is difficult.

*Image shows a Sprinter 170 Van

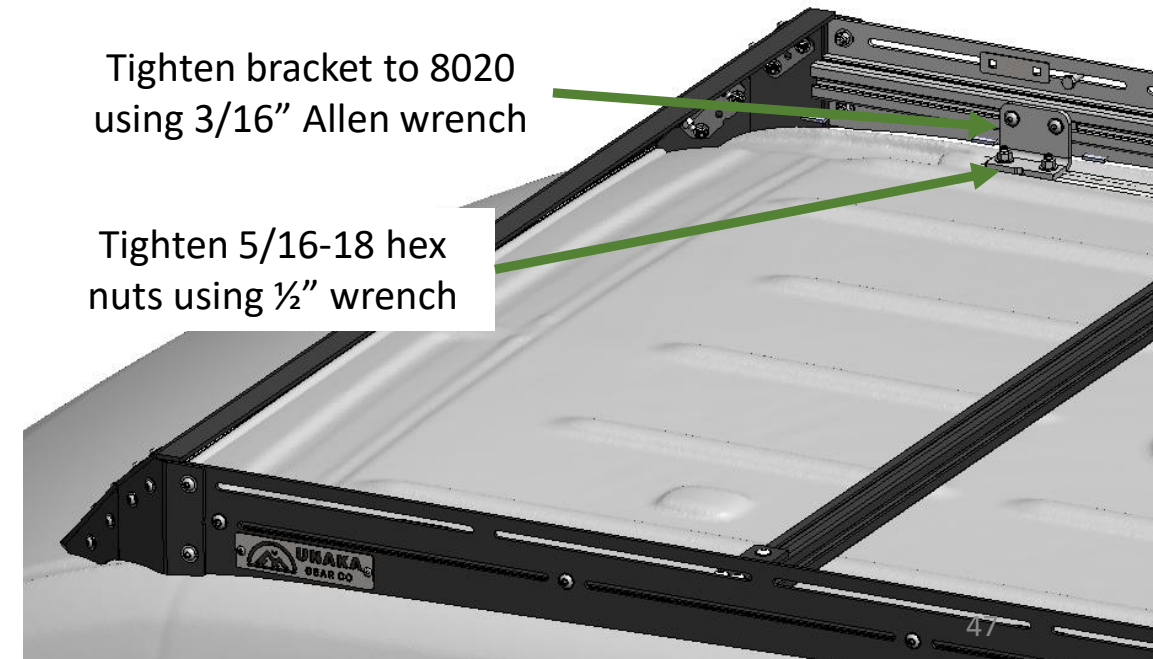
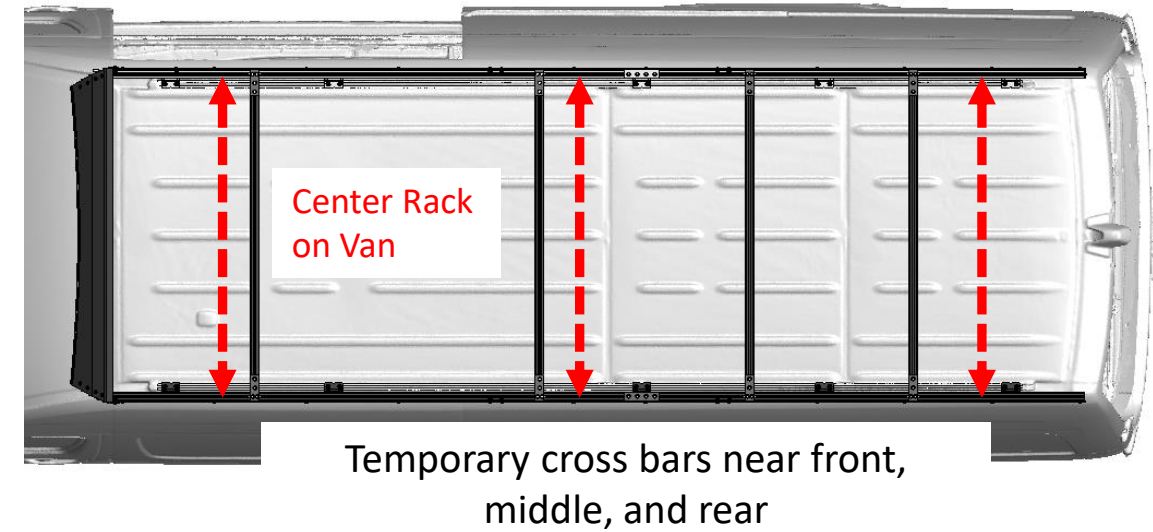

Final Install of Cross Bar Assemblies

1. Remove and reposition any cross bars that were not located in their final locations during the rail to rail spacing step
2. The final position of the cross-bar assemblies can now be set
 - See subsequent pages about potential cross bar and splice plate interferences
 - See subsequent pages on solar panel layouts
3. If you completely loosen, or find your self loosening a bolt that already has Loctite on it several times, remove it and apply some more

Final Torque Checks

Once everything is installed, go back and check that all hardware is tight.

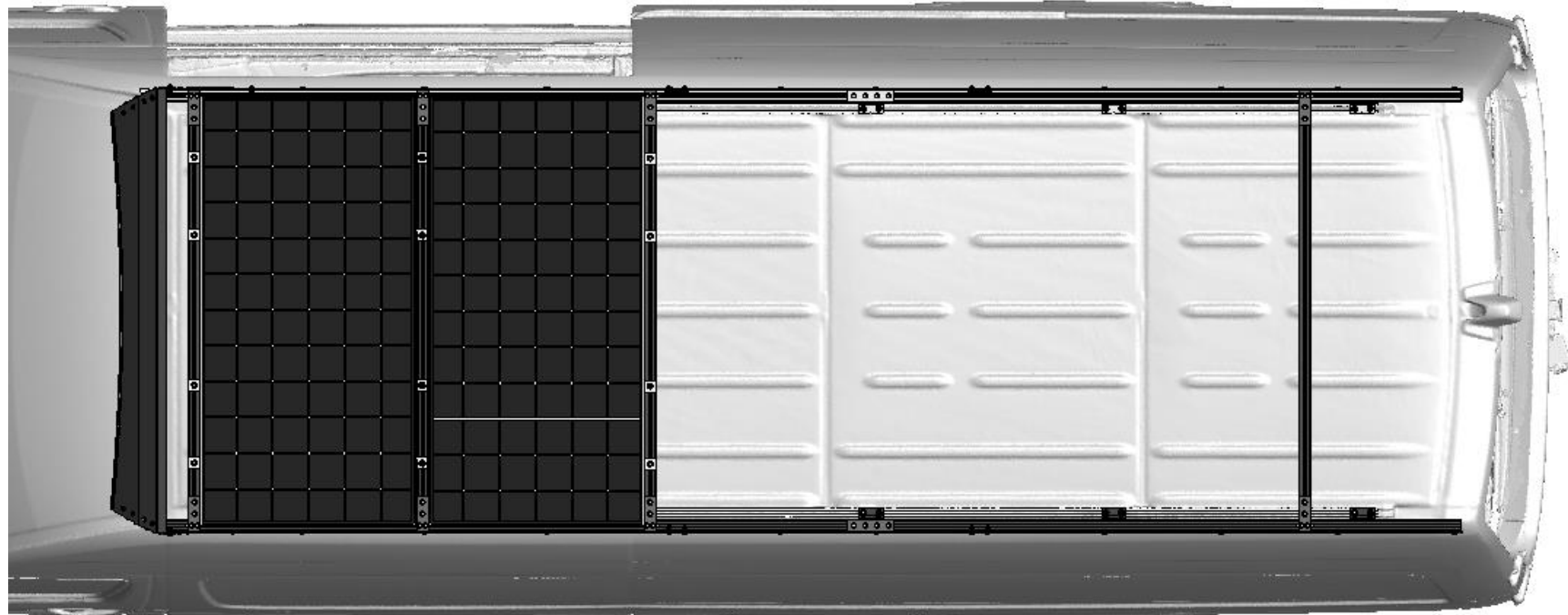
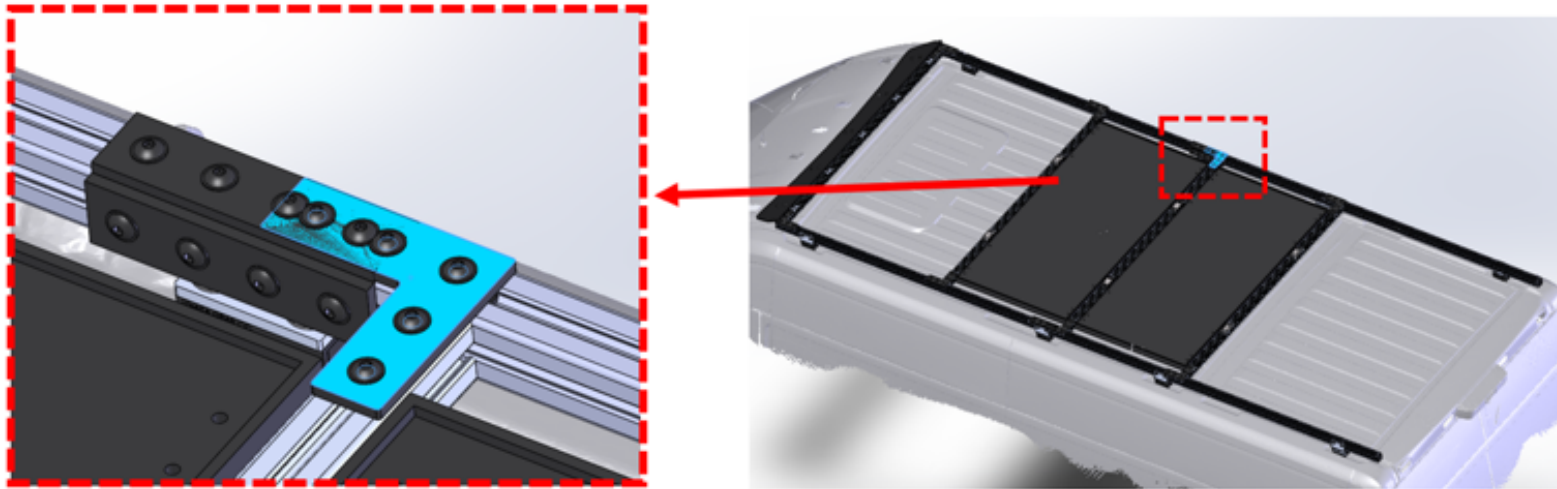

*Image shows a Sprinter 170" WB

Potential Cross Bar to Splice Plate Interference

In some cases, your rack layout may require your cross bars to occupy the same space as the splice plates, see Figure 8. In this example, there are no fans or other items on the roof that would prevent the solar panels and cross bars from being installed a few inches further back to eliminate the interference. If this was not an option, the L-bracket can simply be rotated 180 degrees so that it is pointed away from the splice plates instead of towards them.

Note: The cross-bar bracket shown is an older L-style Bracket. Make adjustments as needed for the old style, or the new narrow style cross bar connectors.



*Image shows a ProMaster 159" WB

Figure 8: Top splice plate and cross bar bracket interference, flip L-bracket 180 degrees or move splice plate

If you cannot re-arrange your layout the following options can be used to eliminate the interference

- If possible, rotate the L-brackets 180 degrees so they do not interfere with the splice plates.
- If the rack is only supporting solar panels and the front and rear side rail are being joined at an Unaka 8020 adapter bracket on one side, then consider just using 1 splice plate instead of both plates.

200W Solar Panel Notes

1. This rack was designed to fit specific 200W solar panels
2. When these panels are installed, they will rest over the top of the 8020 side rails
3. If the solar panel occupies the same area as the splice plate, just remove the splice plate or relocate it to the inside of the side rail if a rack bracket is not used at that location

200W Newpowa Panel:
55.28 x 27.76 x 1.38 in

Edge of panel will
rest over top of
8020 side rail

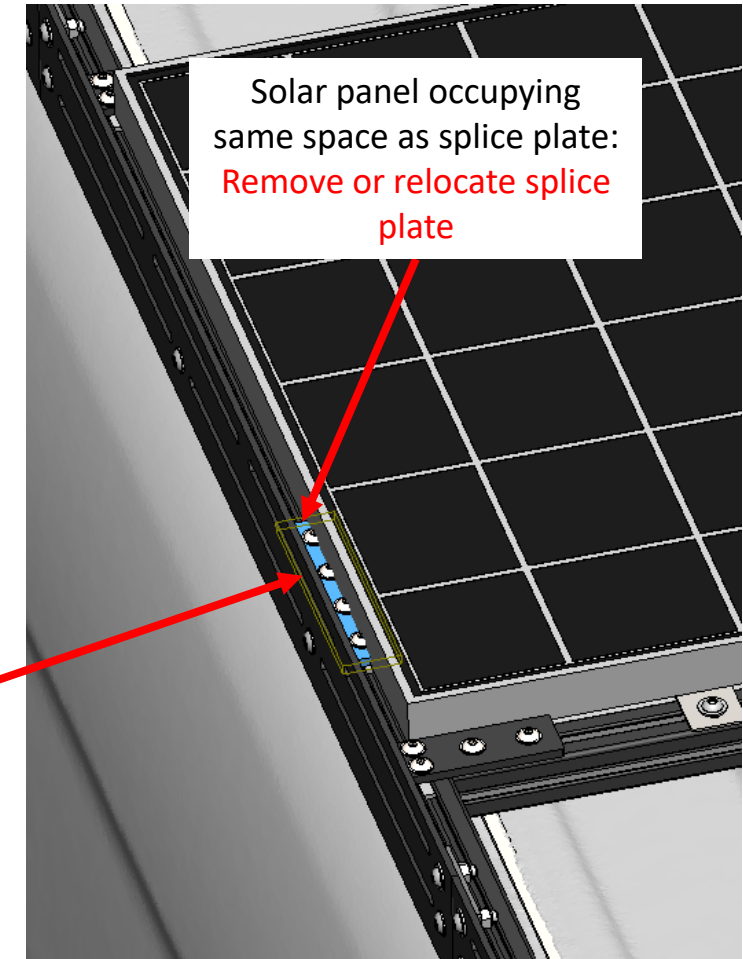
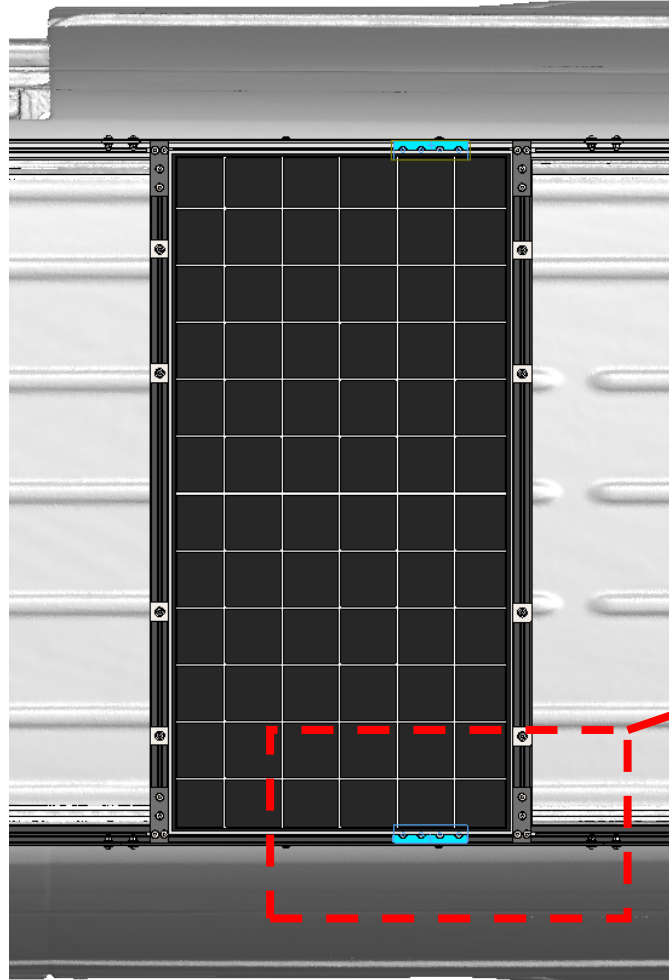

Solar panel occupying
same space as splice plate:
**Remove or relocate splice
plate**

Top Mount Solar Panels: 200W Solar Panel Notes

1. The Unaka Sprinter HSLD rack was designed to fit certain 200W solar panels width wise on the van while still being concealed behind the side plates
2. To accomplish this, these panels must be mounted using our Top Mount solar panel brackets
3. 200W solar panels should be mounted using 8 top mount or flush mount solar panel brackets per panel (4 per side)
4. Max solar panel length is 55.28" long

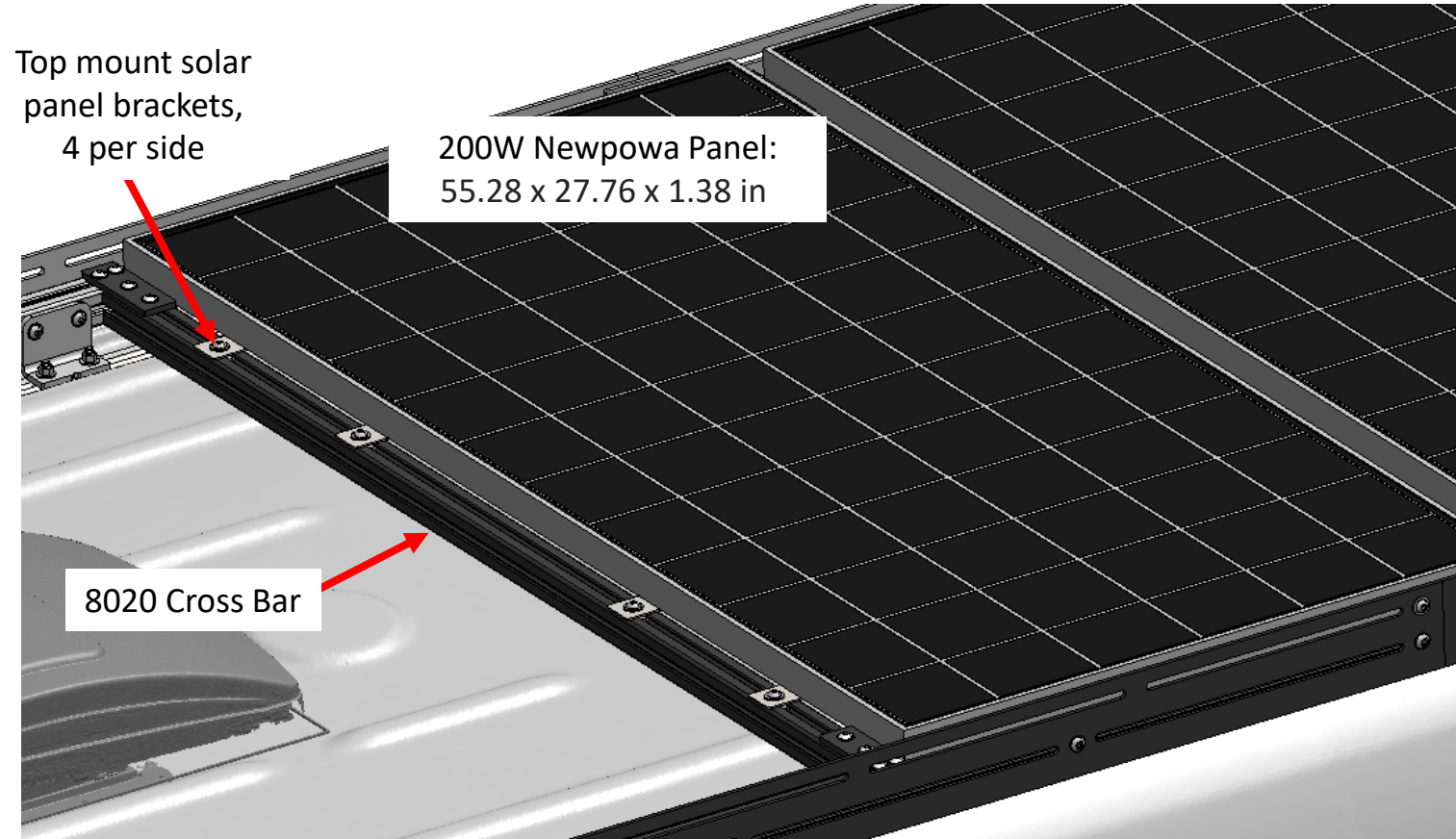
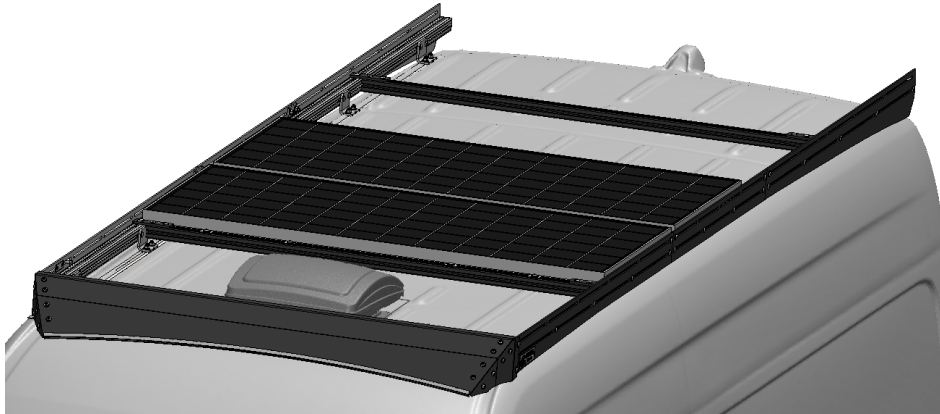

Optional Flush Mount Solar Panels: Renogy 175W Solar Panel

1. If you are using smaller solar panels, you may choose to install them with flush mount solar panel brackets. This allows the solar panels to rest down inside of the cross bars / side rail profiles in a more traditional flush style.
2. To install solar panels with flush mount brackets, the total width must be less than 52.75" which is roughly the useable width between side rails
3. Flush mount solar panel brackets are sold separately
4. Approximately useable width between side rails: 52.75"
5. The Renogy 175W solar panels are 49.7" long and fit down between the cross bars and side rails nicely

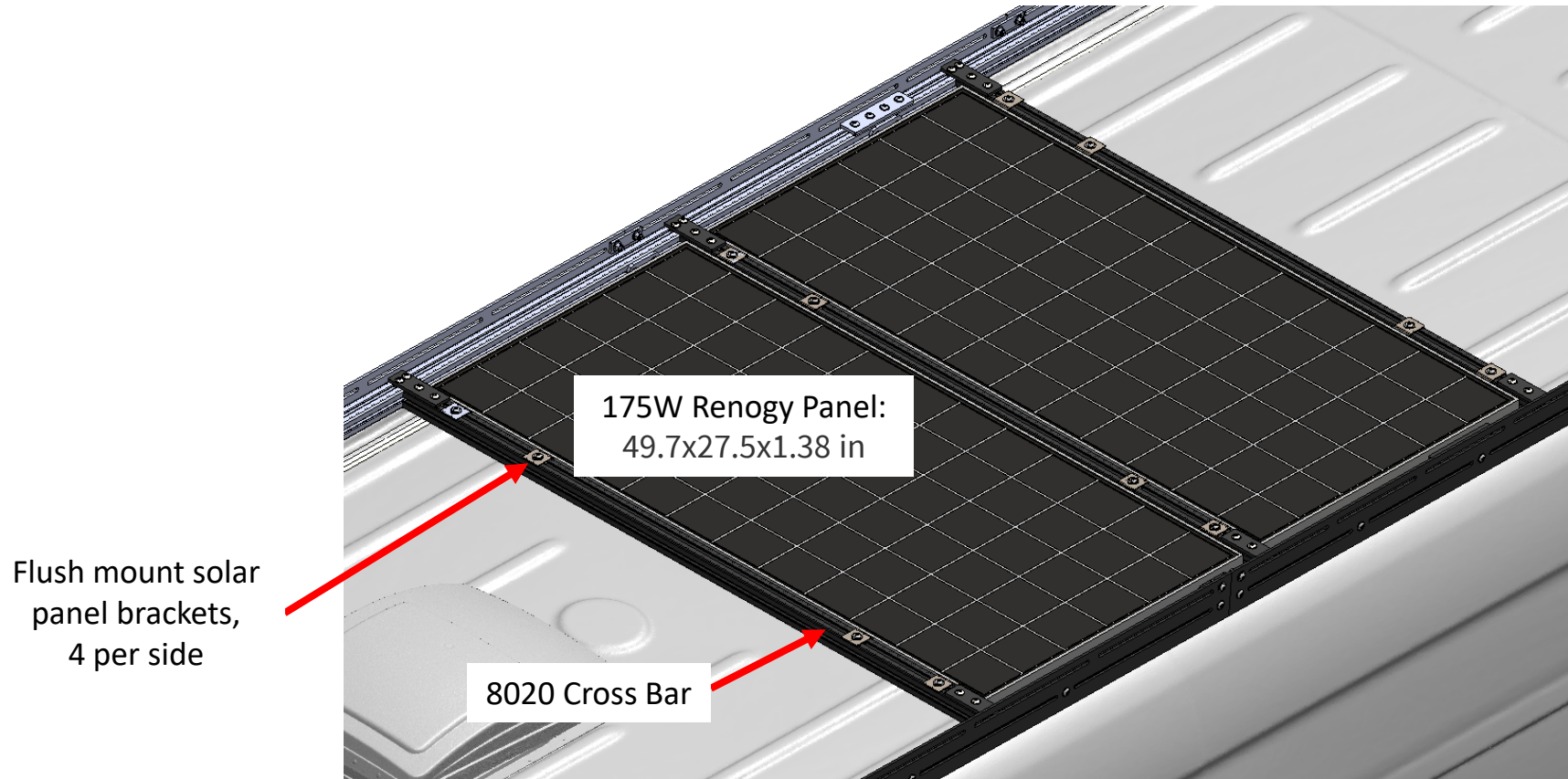

Preventative Maintenance Checks

Even though we do not expect any of the hardware to come loose, we recommend checking your roof rack hardware from time to time to help minimize the chance of something coming loose over time. Using the appropriate wrenches check the roof rack hardware to ensure nothing is coming loose at the intervals below.

- Initial check after 4 to 7 days of moderate driving
- Follow Up Check 1 month after moderate driving
- Routine checks 3 to 4 months of moderate driving
- Anytime after moderate driving on bumpy roads or gravel roads

This completes the installation of your HSLD kit.

Legal Disclaimer:

Unaka Gear Co. makes no warranties whatsoever, expressed, or implied, oral, or written to any purchasers, except the limited warranty described on our website. Unaka Gear Co. is hereby specifically excluded from any implied warranty of incidental, secondary, or consequential damages of any kind whatsoever. All purchasers and users of products manufactured by Unaka Gear Co. agree to hold harmless and indemnify Unaka Gear Co from any and all claims arising from their use. Failure to receive notice of any limitations or the limitations contained in this disclaimer shall not serve to extend liability to Unaka Gear Co. for any claims arising out of use of its products.

