



HSLD Rack Installation Manual: Ram ProMaster 159" WB

SKU: 1001-MK50-01 REV 2

Date: 4/8/24

Revision: 3

Rack Features

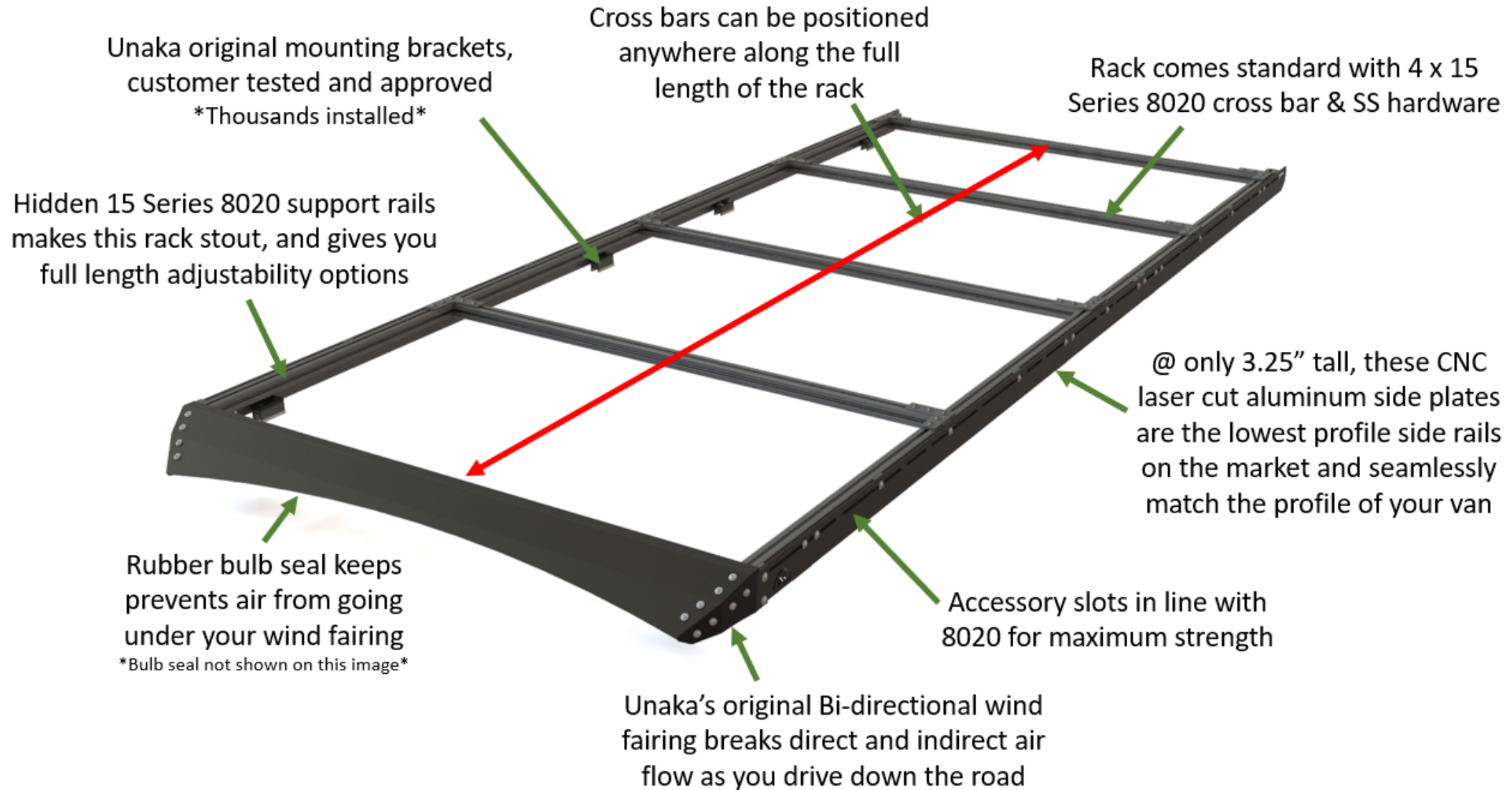

****Note:** The image above is for the ProMaster 159" WB None Extended. The 136" WB and 159" WB Extended contain different side rail lengths, and different quantities of brackets

Rack Accessories

The HSLD rack does not include any additional accessories, and this manual does not include the installation of these accessories. **Failure to review accessory installation manuals may result in extended installation time.**

Use this link to find the manuals for any accessories and Review them before beginning this installation.
<https://unakagearco.com/pages/manuals>

Some of the common accessories purchased separately are listed below.

- Flush Mount Solar Panel Brackets: **Our most popular accessory makes for the cleanest solar panel installation
- Extrusion Tie Down Kits
- Ram ProMaster Side Mount Ladder
- More to come!

Safety and PPE

Ladders: Installation of this roof rack requires two ladders for two people to help with the installation. Make sure that your ladders are tall enough, and that you have a level area to use them on. Accessing the roof of your van will put you at extreme risk to potential falls which can result in injury or death.

Warning: Ladders are dangerous and should only be used with appropriate training. Incorrect use of ladders can result in injury or death.

Fall Protection: Accessing the roof of your van will put you at extreme risk to potential falls which can result in injury or death. Appropriate fall protection should be used when accessing your van roof. For general use situations, OSHA requires that fall protection be provided at elevations of four feet in general industry workplaces.

Required Tools

- 1 to 2 tall sturdy ladders
- Standard set of box wrenches
- Standard socket set
- 5/32" and 3/16" Allen Wrench
- Torque Wrench
- Measuring Tape

Torque Specs & Notes

- Before installing any Unaka Product, review the most up to date manual completely which can be found on our website here: <https://unakagearco.com/pages/manuals>
- The Torque reference manual does not replace any information found on the individual product manual.
- This torque reference is indented as a quick reference overview of our torque specifications
- Incorrect use of a torque wrench will result in damage to the torque wrench, or bolts tightened to the incorrect torque
- Failure to use Loctite thread locker, anti-seize, or torquing your hardware correctly may result in bolts loosening pre-maturely or seizing during installation
- You are responsible for checking your hardware frequently to ensure all hardware remains tight (1 week after the installation, and every 2 months)
- You are responsible for ensuring the torque wrench you are using has been calibrated recently and correctly

Loctite & Anti-seize

A small tube of Blue Loctite 242 and Loctite anti-seize are provided with each kit. Follow manufactures recommendation for application and safety.

Blue Loctite 242

- Apply this to any bolt that is not used with a nylock nut

Loctite Anti-seize

- Apply a dab of anti-seize to the side of each bolt that will be paired with a nylock nut. Nylock nuts have a small plastic insert to make them vibration resistant.



Loctite 242



Loctite C5-A Anti-Seize

Main Rack Parts

This rack kit is typically shipped in 3 separate boxes

ITEM NO.	Manufacturer	PART NUMBER	DESCRIPTION	MATERIAL	QTY.
1	Unaka Gear Co.	1001-MK50-01-MRB REV 0	PROMASTER 159 HSLD MAIN RACK BOX	ASSEMBLY	1
2	Unaka Gear Co.	1001-MA52-00-WFB REV 1	PROMASTER HSLD HIGH ROOF WIND FAIRING BOX	ASSEMBLY	1
3	Unaka Gear Co.	1001-MK50-01-HWB REV 1	PROMASTER 159 HSLD HARDWARE BOX	ASSEMBLY	1

REVISIONS				
ZONE	REV.	DESCRIPTION	DATE	APPROVED
	0	BUMPED REVISION FOR REV CONTROL	5/17/2023	JEO
	2	UPDATED DRAWING TO REFLECT CURRENT KITTING	3/12/2024	JEO

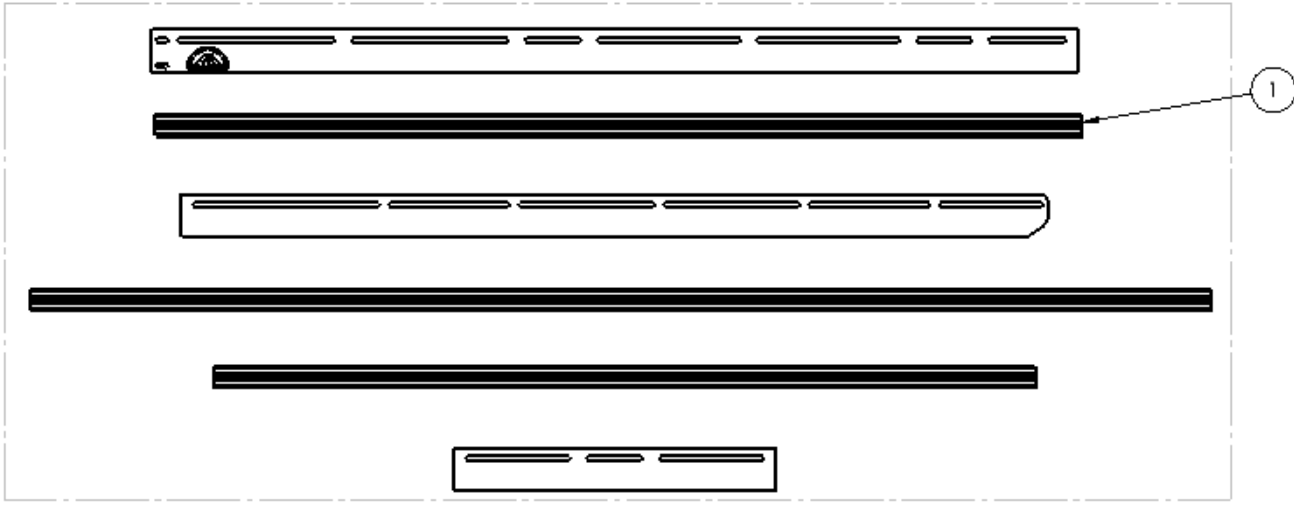

- NOTES:**
- SEE BILL OF MATERIAL FOR TOTAL KITTING QUANTITIES AS IMAGES OF EVERY INDIVIDUAL ITEM MAY NOT BE SHOWN
 - IMAGES ARE SHOWN FOR PART IDENTIFICATION AND DO NOT REFLECT FULL QUANTITIES OF EACH PARTS. SEE SUB ASSEMBLY DRAWINGS AND BOMS FOR EXACT QUANTITIES

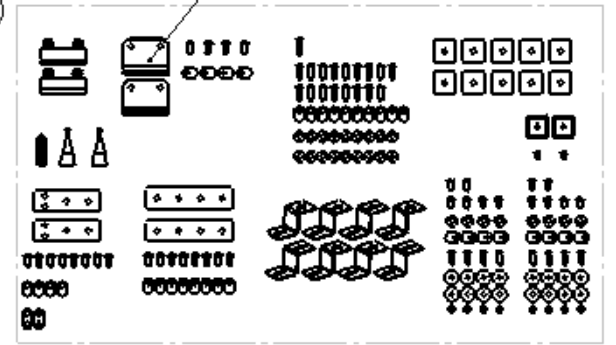

UNLESS OTHERWISE SPECIFIED DIMENSIONS ARE IN INCHES

TOLERANCES:
 ANGULAR: ±0.5°
 ONE PLACE DECIMAL: ±0.1
 TWO PLACE DECIMAL: ±0.01
 THREE PLACE DECIMAL: ±0.005

DO NOT SCALE DRAWING

NAME	DATE
DRAWN	
CHECKED	

TITLE: Ram Promaster Roof Rack - HSLD - 159WB

PROPRIETARY AND CONFIDENTIAL
 THE INFORMATION CONTAINED IN THIS DRAWING IS THE SOLE PROPERTY OF UNAKA GEAR CO. A 4Y REPRODUCTION IN PART OR AS A WHOLE WITHOUT THE WRITTEN PERMISSON OF UNAKA GEAR CO. IS STRICTLY PROHIBITED



SIZE DWG. NO. REV
B 1001-MK50-01 REV 2 **2**

POST PROCESSING: ASSEMBLY
 FINISH: None

SCALE: NTS SHEET 1 OF 1

Main Rack Box

Contains extrusion, side plates, and cross bars: Box Size: 8" x 8" x 91" Long

ITEM NO.	Manufacturer	PART NUMBER	DESCRIPTION	MATERIAL	QTY.
1	Unaka Gear Co.	1001-MB50-01 REV 1	RAM PROMASTER FRONT SIDE PLATE	5052-H32	2
2	Unaka Gear Co.	1001-MB50-02 REV 1	RAM PROMASTER REAR SIDE PLATE	5052-H32	2
3	Unaka Gear Co.	1001-MB50-04 REV 1	RAM 159 NON EXT SPLICE SIDE PLATE	5052-H32	2
4	Unaka Gear Co.	1515-UL-BLACK-56.75	1515-UL-BLACK-56.75	6061 Alloy	4
5	Unaka Gear Co.	1515-UL-BLACK-83.44	8020 Style Extrusion, 15 Series, Ultra Lite, Grooved, Black, 81.56" LG.	6061 Alloy	2
6	Unaka Gear Co.	1515-UL-BLACK-64	8020 Style Extrusion, 15 Series, Ultra Lite, Grooved, Black, 64" LG.	6061 Alloy	2

REVISIONS				
ZONE	REV.	DESCRIPTION	DATE	APPROVED
	0	SET REVISION TO 0 FOR NEW DRAWING REFERENCE	5/17/2023	JEO

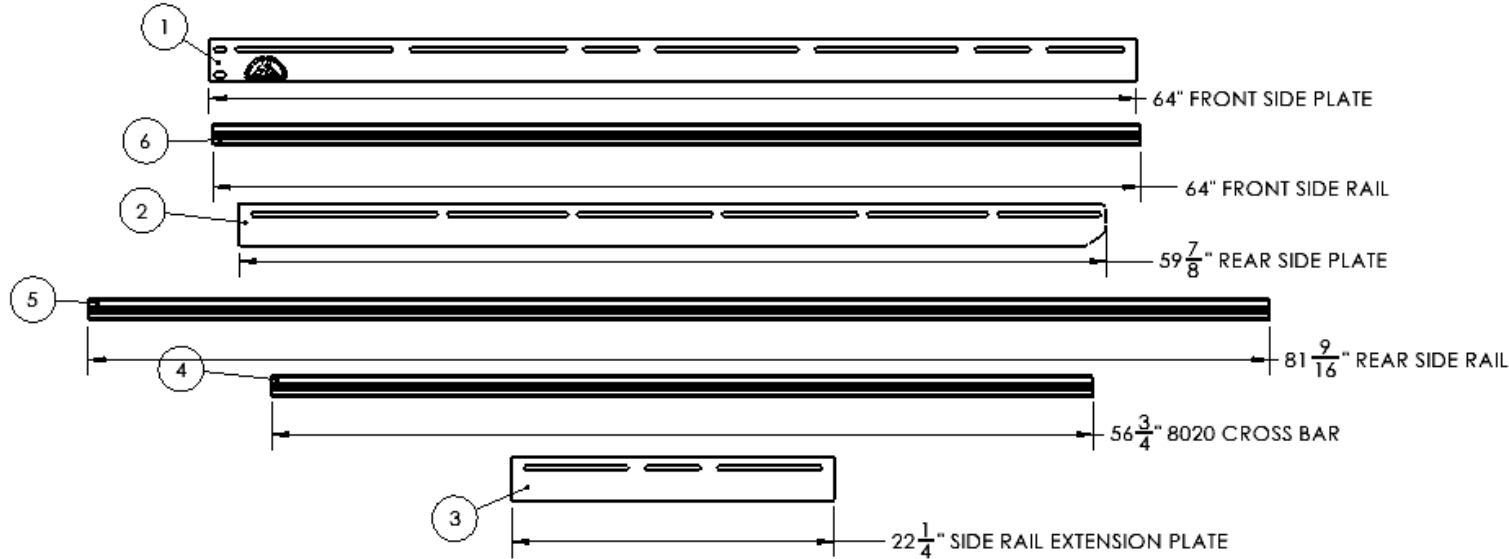

ALL PARTS SHOULD BE WRAPPED CAREFULLY BEFORE BOXING

- NOTES:**
- SEE BILL OF MATERIAL FOR TOTAL KITTING QUANTITIES AS IMAGES OF EVERY INDIVIDUAL ITEM MAY NOT BE SHOWN IDENTIFICATION AND DO NOT REFLECT FULL QUANTITIES OF EACH PARTS. SEE SUB ASSEMBLY DRAWINGS AND BOMS FOR EXACT QUANTITIES
- PACKAGING NOTES**
- ALL ITEMS SHOULD BE PACKAGED CAREFULLY IN A SINGLE BOX.
 - ALL ITEMS SHOULD BE PACKAGED IN A WAY THAT WILL PREVENT DAMAGE OR MOVEMENT DURING SHIPPING
 - BOX SHOULD BE LABELED WITH SKU AND DESCRIPTION

UNLESS OTHERWISE SPECIFIED DIMENSIONS ARE IN INCHES TOLERANCES: ANGULAR: ±0.5° ONE PLACE DECIMAL: ±0.1 TWO PLACE DECIMAL: ±0.01 THREE PLACE DECIMAL: ±0.005	DO NOT SCALE DRAWING		TITLE: PROMASTER 159 HSLD MAIN RACK BOX
	DRAWN BY JEO	NAME JEO	
PROPRIETARY AND CONFIDENTIAL THE INFORMATION CONTAINED IN THIS DRAWING IS THE SOLE PROPERTY OF UNAKA GEAR CO. ANY REPRODUCTION IN PART OR AS A WHOLE WITHOUT THE WRITTEN PERMISSION OF UNAKA GEAR CO. IS STRICTLY PROHIBITED.	CHECKED ---	DATE ---	SIZE B
			DWG. NO. 1001-MK50-01-MRB REV 0
POST PROCESSING: None			REV 0

HSLD Wind Fairing Box

Contains wind fairing pieces, hardware bag, and bulb seal: Box Size: 65 × 13 × 3 in

ITEM NO.	Manufacturer	PART NUMBER	DESCRIPTION	MATERIAL	QTY.
1	Unaka Gear Co.	1001-MB52-01 REV 2	PROMASTER HSLD WIND FAIRING TO END CAP, UPPER BRACKET	5052-H32	2
2	Unaka Gear Co.	1001-MB52-02 REV 2	PROMASTER HSLD WIND FAIRING TO END CAP, LOWER BRACKET	5052-H32	2
3	Unaka Gear Co.	1001-MB52-03 REV 1	RAM PM WIND FAIRING END CAP	5052-H32	1
4	Unaka Gear Co.	1001-MB52-04 REV 1	RAM PM SIDE PLATE END CAP PASSENGER SIDE	5052-H32	1
5	Unaka Gear Co.	1001-MB52-05 REV 1	PROMASTER HSLD WIND FAIRING 2 BENDS	5052-H32	1
6	Unaka Gear Co.	1003-MA52-00-HW REV 0	HSLD WIND FAIRING HARDWARE KIT	ASSEMBLY	1

REVISIONS				
ZONE	REV.	DESCRIPTION	DATE	APPROVED
	0	CREATED REVISION TO START REV CONTROL	5/17/2023	JEO
D4	1	CREATED REV 1 SO KIT REVISION MATCHED SUB PART REVISIONS. ON 3-12-2024 REPLACED ITEMS 1 & 2 WITH REV 2 PARTS. NO PHYSICAL CHANGE IN PARTS, JUST A DESCRIPTION CHANGE	11/13/2023	JEO

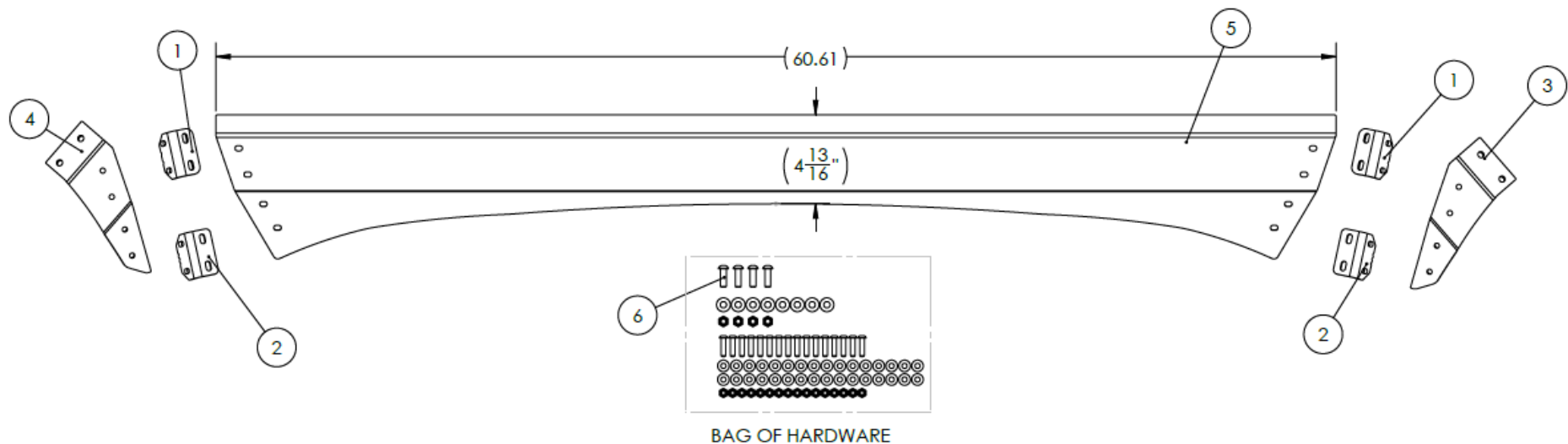

POST PROCESSING: None
FINISH: None

UNLESS OTHERWISE SPECIFIED DIMENSIONS ARE IN INCHES
TOLERANCES:
ANGULAR: ±0.5°
ONE PLACE DECIMAL: ±0.1
TWO PLACE DECIMAL: ±0.01
THREE PLACE DECIMAL: ±0.005

DO NOT SCALE DRAWING

NAME	DATE
DRAWN BY JEO	--
CHECKED --	--

TITLE:
PROMASTER HSLD HIGH ROOF WIND FAIRING BOX

PROPRIETARY AND CONFIDENTIAL
THE INFORMATION CONTAINED IN THIS DRAWING IS THE SOLE PROPERTY OF UNAKA GEAR CO. ANY REPRODUCTION IN PART OR AS A WHOLE WITHOUT THE WRITTEN PERMISSION OF UNAKA GEAR CO. IS STRICTLY PROHIBITED.



SIZE	DWG. NO.	REV
B	1001-MA52-00-WFB REV 1	1

SCALE: NTS SHEET 1 OF 1

HSLD Wind Fairing Hardware

Hardware required for wind fairing assembly, typically shipped in wind fairing box

ITEM NO.	Manufacturer	PART NUMBER	DESCRIPTION	MATERIAL	QTY.
1	ANY	91831A029	LOCKNUT, 1/4-20, 18-8 S.S.	NA	16
2	ANY	91831A030	LOCKNUT, 5/16-18, 18-8 S.S.	NA	4
3	ANY	92141A029-B	WASHER, 1/4", 0.625" OD, 18-8 SS, BLACK	NA	32
4	ANY	92141A030-B	FLAT WASHER, 5/16" SCREW SIZE, 0.344" ID, 0.75" OD, 18-8 SS, BLACK	NA	8
5	ANY	92949A542-B	BHCS, 1/4-20 X 1" LG, SS, BLACK	NA	16
6	ANY	92949A582-B	BHCS, 5/16-18 X 1" LG, FULLY THREADED, 18-8 S.S., BLACK	NA	4

REVISIONS				
ZONE	REV.	DESCRIPTION	DATE	APPROVED
	0	ADDED REVISION FOR REV CONTROL	5/18/2023	JEO

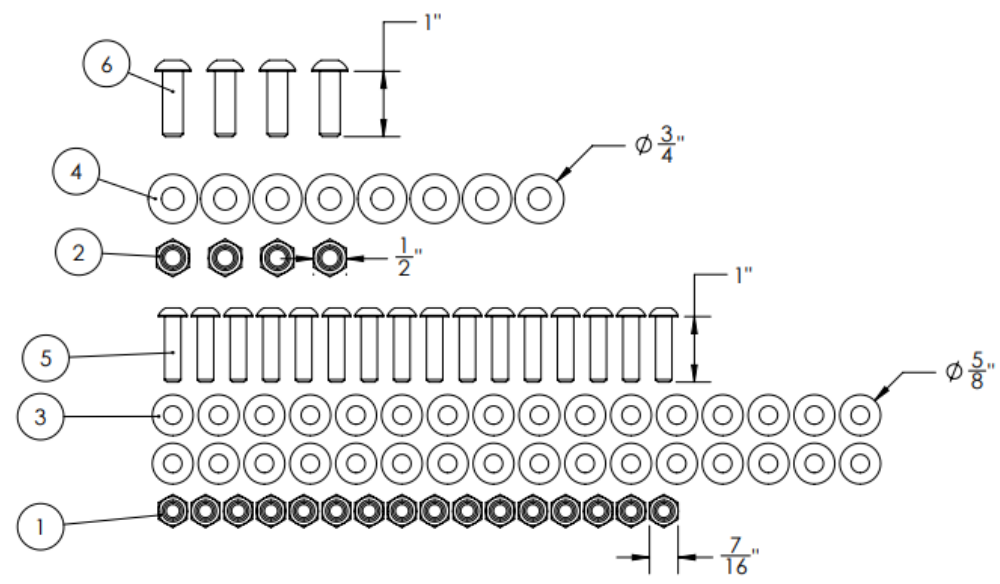

- NOTES:**
1. ALL HARDWARE SHOULD BE BAGGED
 2. HARDWARE BAG/BAGS SHOULD INCLUDE IDENTIFICATION LABEL

POST PROCESSING: None
FINISH: None

UNLESS OTHERWISE SPECIFIED DIMENSIONS ARE IN INCHES
TOLERANCES:
ANGULAR: ±0.5°
ONE PLACE DECIMAL: ±0.1
TWO PLACE DECIMAL: ±0.01
THREE PLACE DECIMAL: ±0.005

DO NOT SCALE DRAWING	
NAME	DATE
DRAWN BY JEO	---
CHECKED	---

TITLE: HSLD WIND FAIRING HARDWARE KIT

PROPRIETARY AND CONFIDENTIAL
THE INFORMATION CONTAINED IN THIS DRAWING IS THE SOLE PROPERTY OF UNAKA GEAR CO. ANY REPRODUCTION IN PART OR AS A WHOLE WITHOUT THE WRITTEN PERMISSION OF UNAKA GEAR CO. IS STRICTLY PROHIBITED.



SIZE B	DWG. NO. 1003-MA52-00-HW REV 0	REV 0
SCALE: NTS		SHEET 1 OF 1

HSLD Hardware Box

All remaining pieces required to assemble and install your roof rack (Typical Box: 10 × 6 × 4 in)

ITEM NO.	Manufacturer	PART NUMBER	DESCRIPTION	MATERIAL	QTY.
1	Loctite	1821A11	Antiseize, lb8008, Electrically Conductive, 0.2 oz. Pack	NA	1
2	Loctite	91458A111	Threadlocker, Loctite® 242, 0.02 FL. oz Capsule	NA	2
3	Unaka Gear Co.	1001-MK10-00 REV 0	RAM PROMASTER ROOF RACK BRACKET SET OF 2	ASSEMBLY	4
4	Unaka Gear Co.	1001-MK12-00 REV 1	Unaka Roof Rack 8020 Adapter Brackets - Set of 2	ASSEMBLY	4
5	Unaka Gear Co.	1001-MK50-01-HW1 REV 1	PROMASTER 159 HSLD SIDE RAIL HARDWARE KIT	ASSEMBLY	2
6	Unaka Gear Co.	1001-MK50-01-HW2 REV 1	PROMASTER 159 HSLD SIDE RAIL SPACERS, 1/4" THICK, SET OF 10	ASSEMBLY	2
7	Unaka Gear Co.	1005-MK01-00 REV 0	Splice Plate Kit, Set of 2 x 4 Hole Flat Plates with Hardware	ASSEMBLY	1
8	Unaka Gear Co.	1005-MK05-00-HW REV 0	CROSS BAR BRACKETS & HARDWARE FOR Qty. 4 8020 CROSS BARS	ASSEMBLY	1
9	Unaka Gear Co.	1001-MK27-00 REV 2	FLUSH MOUNT SOLAR PANEL BRACKET, SET OF 8 W/8020 HARDWARE	ASSEMBLY	2
10	Unaka Gear Co.	1005-MK08-00 REV 0	8020 STYLE 15 SERIES END CAPS, SET OF 2	ASSEMBLY	1

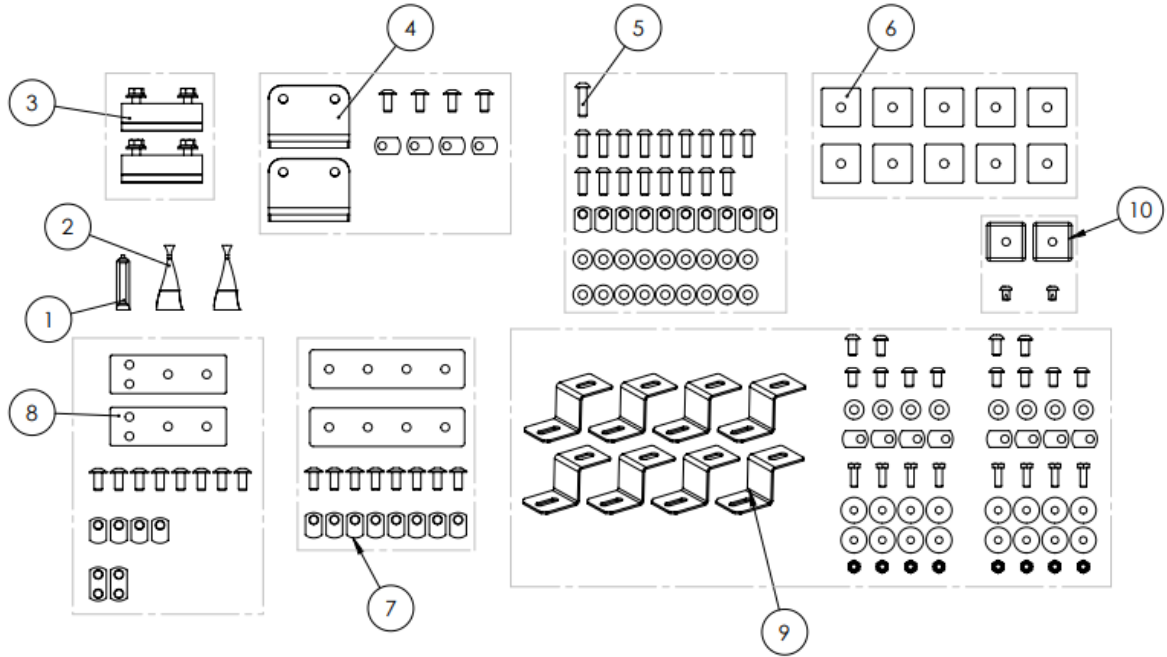

- NOTES:**
- SEE BILL OF MATERIAL FOR TOTAL KITTING QUANTITIES AS IMAGES OF EVERY INDIVIDUAL ITEM MAY NOT BE SHOWN
 - IMAGES ARE SHOWN FOR PART IDENTIFICATION AND DO NOT REFLECT FULL QUANTITIES OF EACH PARTS, SEE SUB ASSEMBLY DRAWINGS AND BOMS FOR EXACT QUANTITIES
- PACKAGING NOTES**
- ALL ITEMS SHOULD BE PACKAGED CAREFULLY IN A SINGLE BOX.
 - ALL ITEMS SHOULD BE PACKAGED IN A WAY THAT WILL PREVENT DAMAGE OR MOVEMENT DURING SHIPPING
 - BOX SHOULD BE LABELED WITH SKU AND DESCRIPTION

REVISIONS				
ZONE	REV.	DESCRIPTION	DATE	APPROVED
	0	BUMPED REVISION FOR RELEASE	5/17/2023	JEO
	1	UPDATED SUB HARDWARE KITS FOR EASIER KITTING	11/7/2023	JEO

POST PROCESSING: None
FINISH: None

UNLESS OTHERWISE SPECIFIED DIMENSIONS ARE IN INCHES
TOLERANCES:
 ANGULAR: ±0.5°
 ONE PLACE DECIMAL: ±0.1
 TWO PLACE DECIMAL: ±0.01
 THREE PLACE DECIMAL: ±0.005

PROPRIETARY AND CONFIDENTIAL
 THE INFORMATION CONTAINED IN THIS DRAWING IS THE SOLE PROPERTY OF UNAKA GEAR CO. ANY REPRODUCTION IN PART OR AS A WHOLE WITHOUT THE WRITTEN PERMISSION OF UNAKA GEAR CO. IS STRICTLY PROHIBITED.

DO NOT SCALE DRAWING	
NAME	DATE
DRAWN BY: JEO	---
CHECKED	---



TITLE: PROMASTER 159 HSLD HARDWARE BOX		
SIZE B	DWG. NO. 1001-MK50-01-HWB REV 1	REV 1
SCALE: NTS	SHEET 1 OF 2	

HSLD Rack Bracket

Quantity 4 Total

Brackets required for bolting to van roof rails and 8020 side rails

ITEM NO.	PART NUMBER	DESCRIPTION	MATERIAL	QTY.
1	1001-MA10-00 REV 0	RACK BRACKET ASSEMBLY	ASSEMBLY	1
2	1001-MK10-00-BOX	PROMASTER RACK BRACKET BOX	Material <not specified>	1
3	1001-MP10-03 REV 0	RUBBER TRIM, 1/8" WIDE, 1/4" TALL INSIDE, EPDM, 3.125" LG	TRIMLOK PN#: X2003 OR EQUIVALENT	4

REVISIONS				
ZONE	REV.	DESCRIPTION	DATE	APPROVED
CS	0	INITIAL KITTING REVISION	1/8/2021	JEO

ITEM 2 IS NOT SHOWN ON THIS DRAWING

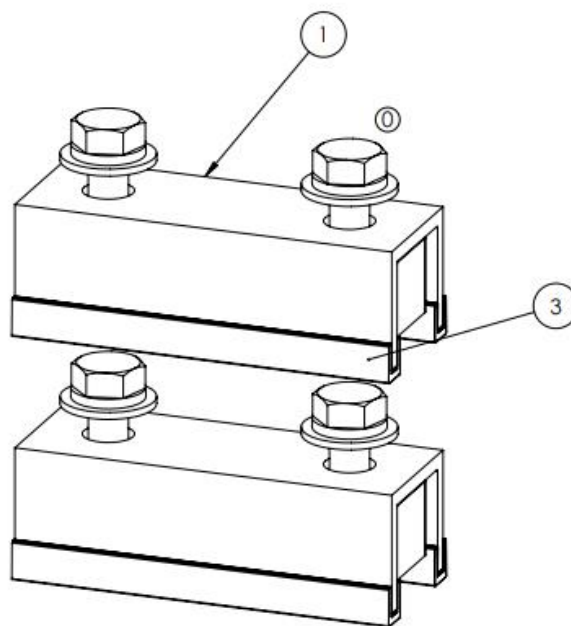

NOTES:

1. INSTALL HARDWARE SECURING INNER NUT PLATE TO CHANNEL
2. SLIDE RUBBER TRIM ONTO FEET OF BRACKETS
3. PLACE BOTH BRACKETS WITH RUBBER INTO BOX
4. APPLY LABEL TO BOX AS REQUIRED

UNLESS OTHERWISE SPECIFIED DIMENSIONS ARE IN INCHES TOLERANCES: ANGULAR: ±0.5° ONE PLACE DECIMAL: ±0.1 TWO PLACE DECIMAL: ±0.01 THREE PLACE DECIMAL: ±0.005	DO NOT SCALE DRAWING		TITLE:	
	NAME	DATE	RAM PROMASTER ROOF RACK BRACKET SET OF 2	
PROPRIETARY AND CONFIDENTIAL THE INFORMATION CONTAINED IN THIS DRAWING IS THE SOLE PROPERTY OF UNAKA GEAR CO. ANY REPRODUCTION IN PART OR AS A WHOLE WITHOUT THE WRITTEN PERMISSION OF UNAKA GEAR CO. IS STRICTLY PROHIBITED.	DRAWN BY	JEO	---	---
	CHECKED	---	---	---
POST PROCESSING: FINISH: None	UNAKA GEAR CO		SIZE	DWG. NO.
	UNAKA GEAR CO		B	1001-MK10-00 REV 0
			REV	0
		SCALE: NTS		SHEET 1 OF 1

HSLD Rack Bracket Adapter

Quantity 4 Total

Adapter brackets required for bolting to van roof rails and 8020 side rails

ITEM NO.	PART NUMBER	DESCRIPTION	MATERIAL	QTY.
1	1001-MP12-01 REV B	PROMASTER ROOF RACK BRACKET 8020 ADAPTER	5052-H32	2
2	1001-MK12-00-HW REV 1	PROMASTER ROOF RACK BRACKET 8020 ADAPTER HARDWARE	ASSEMBLY	1

REVISIONS				
ZONE	REV.	DESCRIPTION	DATE	APPROVED
	B	ADJUSTED BEND ANGLE AND INCREASED LOWER HOLE DIAMETER	12/6/2020	JEO
	1	MOVED HARDWARE TO SUB BAG. ON 11-7-23 ADDED REVISION TO ADAPTER BRACKET NAME (NO PHYSICAL CHANGE)	10/2/2023	JEO

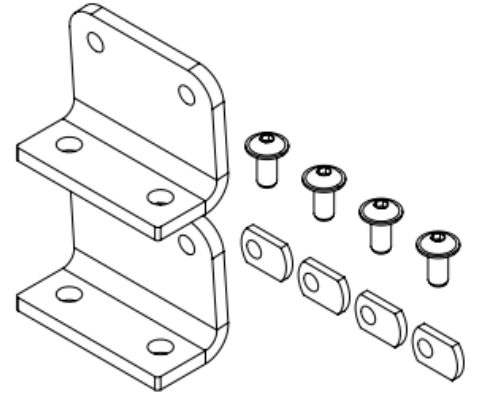
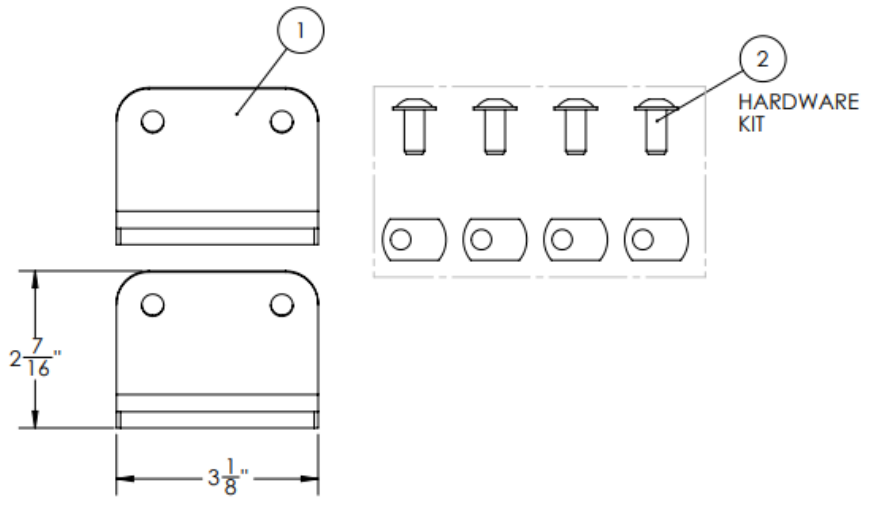

KITTING NOTES:

1. LABEL AND BAG HARDWARE
2. WRAP OR BOX BOTH BRACKETS AND HARDWARE
3. LABEL COMPLETE KIT / BOX

<small>UNLESS OTHERWISE SPECIFIED DIMENSIONS ARE IN INCHES</small> <small>TOLERANCES:</small> ANGULAR: $\pm 0.5^\circ$ ONE PLACE DECIMAL: ± 0.1 TWO PLACE DECIMAL: ± 0.01 THREE PLACE DECIMAL: ± 0.005	<small>DO NOT SCALE DRAWING</small>		TITLE: Unaka Roof Rack 8020 Adapter Brackets - Set of 2		
	<small>NAME</small>	<small>DATE</small>			<small>DRAWN BY</small>
			JEO		
<small>PROPRIETARY AND CONFIDENTIAL</small> <small>THE INFORMATION CONTAINED IN THIS DRAWING IS THE SOLE PROPERTY OF UNAKA GEAR CO. ANY REPRODUCTION IN PART OR AS A WHOLE WITHOUT THE WRITTEN PERMISSION OF UNAKA GEAR CO. IS STRICTLY PROHIBITED.</small>	 UNAKA GEAR CO		<small>SIZE</small>	<small>DWG. NO.</small>	<small>REV</small>
	B	1001-MK12-00 REV 1	1		
<small>POST PROCESSING:</small>	<small>FINISH:</small>	<small>None</small>	<small>None</small>	<small>SCALE: NTS</small>	<small>SHEET 1 OF 1</small>

HSLD Rack Bracket Adapter Hardware

Quantity 4 Total

Adapter bracket hardware required for bolting to van roof rails and 8020 side rails

ITEM NO.	Manufacturer	PART NUMBER	DESCRIPTION	MATERIAL	LENGTH	QTY.
1	Any	3607	BHCS, FLANGED, 5/16 X 0.687" LG., S.S., BLACK	NA		4
2	ANY	3678	T-NUT, ECONOMY, 5/16 THREAD, SS	NA		4

REVISIONS				
ZONE	REV.	DESCRIPTION	DATE	APPROVED
	1	CREATED INITIAL REVISION AT REV 1 TO MATCH BRACKET ASSEMBLY REV LEVEL	10/2/2023	JEO

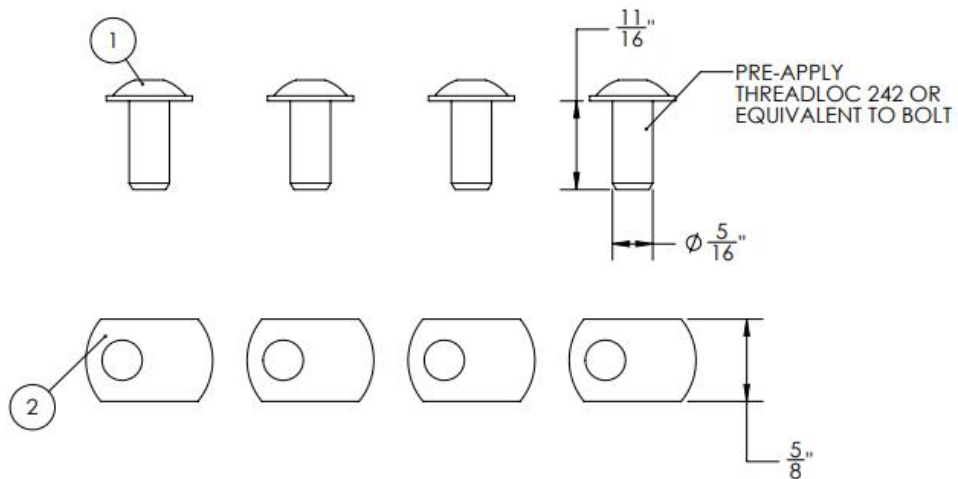

KITTING NOTES:

1. PLACE ALL HARDWARE IN BAG
2. PLACE SKU LABEL AND DESCRIPTION ON BAG

POST PROCESSING: ASSEMBLY
FINISH: None

UNLESS OTHERWISE SPECIFIED DIMENSIONS ARE IN INCHES
TOLERANCES:
ANGULAR: ±0.5°
ONE PLACE DECIMAL: ±0.1
TWO PLACE DECIMAL: ±0.01
THREE PLACE DECIMAL: ±0.005

DO NOT SCALE DRAWING		
	NAME	DATE
DRAWN	---	---
CHECKED	---	---

TITLE:
PROMASTER ROOF RACK
BRACKET 8020 ADAPTER
HARDWARE

PROPRIETARY AND CONFIDENTIAL
THE INFORMATION CONTAINED IN THIS DRAWING IS THE SOLE PROPERTY OF UNAKA GEAR CO. ANY REPRODUCTION IN PART OR AS A WHOLE WITHOUT THE WRITTEN PERMISSION OF UNAKA GEAR CO. IS STRICTLY PROHIBITED.



SIZE B	DWG. NO. 1001-MK12-00-HW REV 1	REV 1
SCALE: NTS		SHEET 1 OF 1

HSLD Side Rail Hardware

Quantity 2 Total

Hardware required for assembling side rails

ITEM NO.	Manufacturer	PART NUMBER	DESCRIPTION	MATERIAL	QTY.
1	ANY	3678	T-NUT, ECONOMY, 5/16 THREAD, SS	NA	10
2	ANY	92141A030-B	FLAT WASHER, 5/16" SCREW SIZE, 0.344" ID, 0.75" OD, 18-8 SS, BLACK	NA	18
3	ANY	92949A583-B	BHCS, 5/16-18 X 7/8" LG, FULLY THREADED, 18-8 S.S., BLACK	NA	17
4	ANY	92949A854-B	BHCS, 5/16-18 X 1-1/8" LG, FULLY THREADED, 18-8 S.S., BLACK	NA	1

REVISIONS				
ZONE	REV.	DESCRIPTION	DATE	APPROVED
	0	BUMPED REVISION FOR REV CONTROL	5/17/2023	JEO
	1	REMOVED SPACERS AND END CAPS, ADJUSTED HARDWARE QUANTITY FOR NEW KITTING PROCESS	11/7/2023	JEO

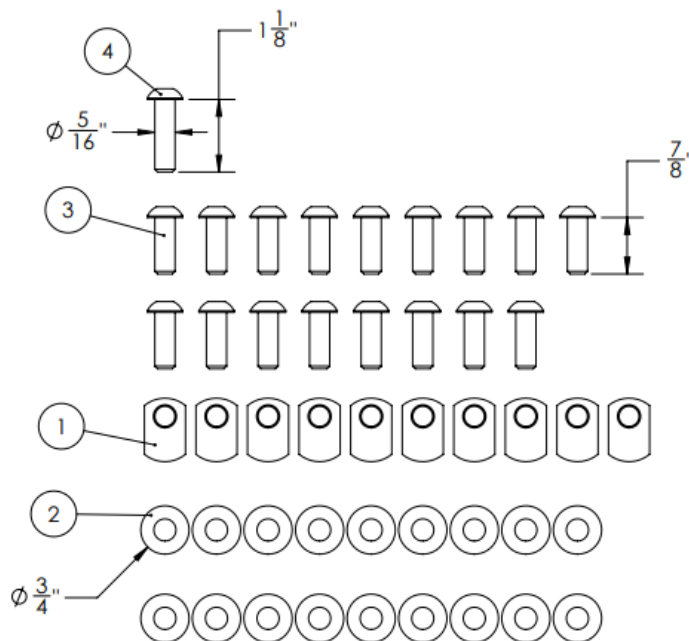

KITTING NOTES:

- ALL HARDWARE SHOULD BE BAGGED
- ALL TYPES OF HARDWARE CAN BE BAGGED IN A SINGLE BAG, OR IN INDIVIDUAL BAGS BASED ON HARDWARE SIZE THEN PLACED IN A LARGER BAG
- MAIN HARDWARE BAG SHOULD INCLUDE SKU IDENTIFICATION LABEL

UNLESS OTHERWISE SPECIFIED DIMENSIONS ARE IN INCHES		DO NOT SCALE DRAWING		TITLE:	
TOLERANCES: ANGULAR: ±0.5° ONE PLACE DECIMAL: ±0.1 TWO PLACE DECIMAL: ±0.01 THREE PLACE DECIMAL: ±0.005		NAME	DATE	PROMASTER 159 HSLD SIDE RAIL HARDWARE KIT	
PROPRIETARY AND CONFIDENTIAL THE INFORMATION CONTAINED IN THIS DRAWING IS THE SOLE PROPERTY OF UNAKA GEAR CO. ANY REPRODUCTION IN PART OR AS A WHOLE WITHOUT THE WRITER'S PERMISSION OF UNAKA GEAR CO. IS STRICTLY PROHIBITED.		DRAWN BY	CHECKED	SIZE	DWG. NO.
POST PROCESSING: None FINISH: None		JEO	---	B	1001-MK50-01-HW1 REV 1
UNAKA GEAR CO		SCALE: NTS		REV	1
				SHEET 1 OF 1	

HSLD Side Rail Spacers

Side rail spacers required for assembling side rails

Quantity 2 Total

ITEM NO.	Manufacturer	PART NUMBER	DESCRIPTION	MATERIAL	QTY.
1	Unaka Gear Co.	1001-MB50-03 REV 0	RAM PM 0.25" SIDE PLATE SPACER	5052-H32	10

REVISIONS				
ZONE	REV.	DESCRIPTION	DATE	APPROVED
	0	BUMPED REVISION FOR REV CONTROL	5/17/2023	JEO
	1	MOVED SPACERS TO STAND ALONE	11/7/2023	JEO

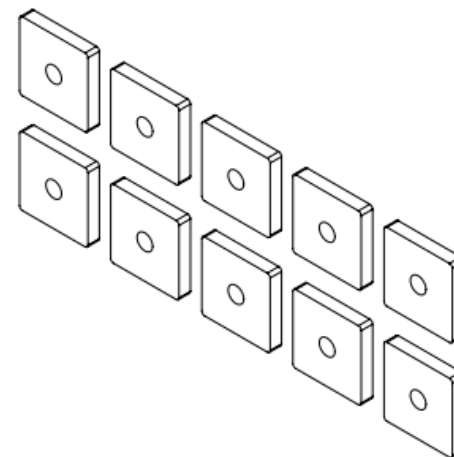
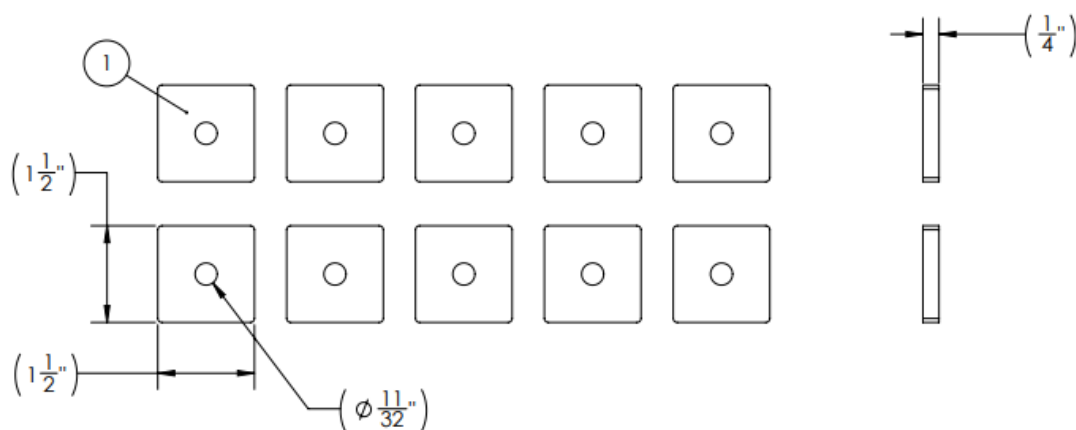

NOTES:

1. PLACE SPACERS IN BAG
2. HARDWARE BAG/BAGS SHOULD INCLUDE IDENTIFICATION LABEL

UNLESS OTHERWISE SPECIFIED DIMENSIONS ARE IN INCHES		DO NOT SCALE DRAWING		TITLE:	
TOLERANCES: ANGULAR: $\pm 0.5^\circ$ ONE PLACE DECIMAL: ± 0.1 TWO PLACE DECIMAL: ± 0.01 THREE PLACE DECIMAL: ± 0.005		NAME	DATE	PROMASTER 159 HSLD SIDE RAIL SPACERS, 1/4" THICK, SET OF 10	
PROPRIETARY AND CONFIDENTIAL THE INFORMATION CONTAINED IN THIS DRAWING IS THE SOLE PROPERTY OF UNAKA GEAR CO. ANY REPRODUCTION IN PART OR AS A WHOLE WITHOUT THE WRITTEN PERMISSION OF UNAKA GEAR CO. IS STRICTLY PROHIBITED.		DRAWN BY	JEO	SIZE	DWG. NO.
POST PROCESSING: None		CHECKED		B	1001-MK50-01-HW2 REV 1
FINISH: None		UNAKA GEAR CO		REV	1
		SCALE: NTS		SHEET 1 OF 1	

HSLD Side Plate Bracket

Quantity 1 Total

Side plate splice hardware kit

ITEM NO.	Manufacturer	PART NUMBER	DESCRIPTION	MATERIAL	QTY.	REVISIONS				
						ZONE	REV.	DESCRIPTION	DATE	APPROVED
1	ANY	3678	T-NUT, ECONOMY, 5/16 THREAD, SS	NA	8					
2	Any	3607	BHCS, FLANGED, 5/16 X 0.687" LG., S.S., BLACK	NA	8					
3	Unaka Gear Co.	1005-MB01-01	STRAIGHT FLAT PLATE, 15 SERIES, 4 HOLE	6061 Alloy	2		0	BUMPED REVISION FOR RELEASE	9/11/2023	JEO

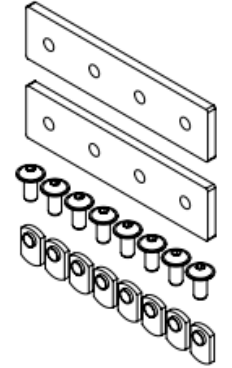
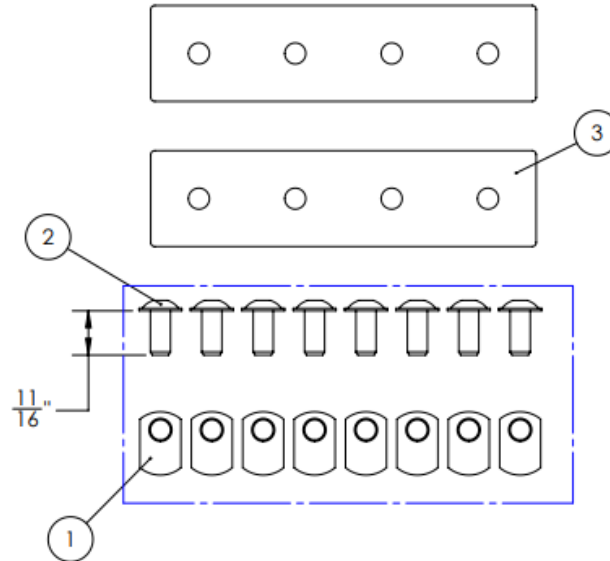

ALL KIT PARTS SHOWN

FINISH NOTES:

- 3607 FINISH SHOULD BE BLACK & HAVE PRE-APPLIED THREAD LOCK TO THREADS
- 4 HOLE PLATE SHOULD BE UV RESISTANT BLACK POWDER COAT

KITTING NOTES:

- HARDWARE SHOULD BE BAGGED
- HARDWARE BAG SHOULD BE LABELED
- ALL PARTS SHOULD BE PACKAGED WITH THE PART NUMBER AND DESCRIPTION LOCATED LABELED ON THE OUTSIDE OF THE PACKAGE
- IF FORMAL PACKAGE DESIGN HAS NOT BE PROVIDED, CAREFULLY WRAP BAG OF HARDWARE TO BRACKETS USING SHRINK WRAP, AND APPLY LABEL TO OUTSIDE

<small>UNLESS OTHERWISE SPECIFIED DIMENSIONS ARE IN INCHES</small> TOLERANCES: ANGULAR: ±0.5° ONE PLACE DECIMAL: ±0.1 TWO PLACE DECIMAL: ±0.01 THREE PLACE DECIMAL: ±0.005	DO NOT SCALE DRAWING		TITLE: Splice Plate Kit, Set of 2 x 4 Hole Flat Plates with Hardware
	<small>PROPRIETARY AND CONFIDENTIAL</small> THE INFORMATION CONTAINED IN THIS DRAWING IS THE SOLE PROPERTY OF UNAKA GEAR CO. ANY REPRODUCTION IN PART OR AS A WHOLE WITHOUT THE WRITTEN PERMISSION OF UNAKA GEAR CO. IS STRICTLY PROHIBITED.	NAME: _____ DATE: _____ DRAWN BY: JEO CHECKED: _____	
POST PROCESSING: None FINISH: None			SCALE: NTS SHEET 1 OF 1

HSLD Cross Bar Bracket

Quantity 1 Total

Cross bar hardware kit

ITEM NO.	Manufacturer	PART NUMBER	DESCRIPTION	MATERIAL	QTY.
1	Any	3607	BHCS, FLANGED, 5/16 X 0.687" LG., S.S., BLACK	NA	32
2	ANY	3678	T-NUT, ECONOMY, 5/16 THREAD, SS	NA	16
3	Unaka Gear Co.	1005-MB03-01 REV 0	NARROW CROSS BAR CONNECTOR, 15 SERIES, 4 HOLE	6061 Alloy	8
4	Unaka Gear Co.	1005-MP00-01 REV 0	DOUBLE T-NUT, 15 SERIES, ECONOMY, 5/16-18 THREAD, SS	AISI 304	8

REVISIONS				
ZONE	REV.	DESCRIPTION	DATE	APPROVED
	0	BUMPED REVISION FOR RELEASE	8/31/2023	JEO

NOTES:

- THIS IMAGE SHOWS THE PARTS REQUIRED TO INSTALL 1 X 8020 CROSS BAR ASSEMBLY
- THE QUANTITIES SHOWN IN THE BOM ABOVE ARE TOTAL PARTS INCLUDED IN THIS KIT WHICH IS TO INSTALL QTY. 4 CROSS BAR ASSEMBLIES

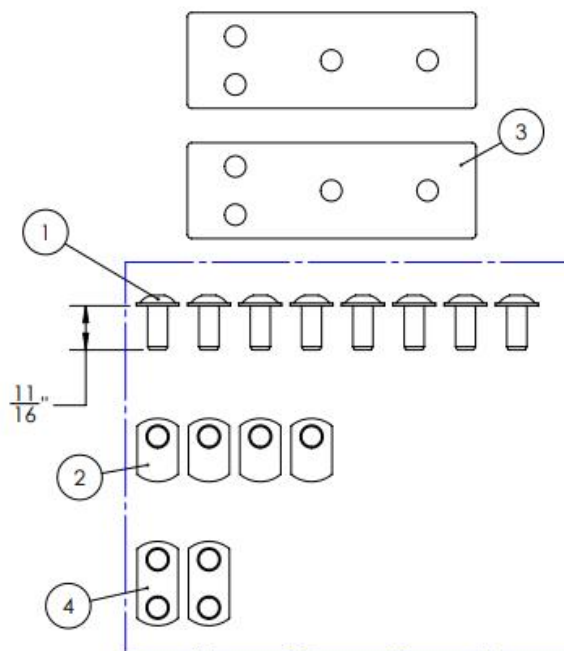

BAG AND LABEL HARDWARE

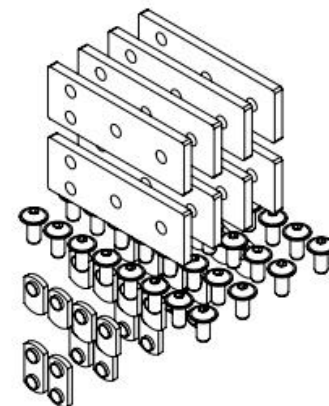

ALL KIT PARTS SHOWN

KITTING NOTES:

- HARDWARE SHOULD BE BAGGED
- HARDWARE BAG SHOULD BE LABELED
- ALL PARTS SHOULD BE PACKAGED WITH THE PART NUMBER AND DESCRIPTION LOCATED LABELED ON THE OUTSIDE OF THE PACKAGE
- IF FORMAL PACKAGE DESIGN HAS NOT BE PROVIDED, CAREFULLY WRAP BAG OF HARDWARE TO BRACKETS USING SHRINK WRAP, AND APPLY LABEL TO OUTSIDE

UNLESS OTHERWISE SPECIFIED DIMENSIONS ARE IN INCHES

TOLERANCES:
 ANGULAR: ±0.5°
 ONE PLACE DECIMAL: ±0.1
 TWO PLACE DECIMAL: ±0.01
 THREE PLACE DECIMAL: ±0.005

PROPRIETARY AND CONFIDENTIAL
 THE INFORMATION CONTAINED IN THIS DRAWING IS THE SOLE PROPERTY OF UNAKA GEAR CO. ANY REPRODUCTION IN PART OR AS A WHOLE WITHOUT THE WRITTEN PERMISSION OF UNAKA GEAR CO. IS STRICTLY PROHIBITED.

DO NOT SCALE DRAWING		
NAME	DATE	
DRAWN BY JEO		
CHECKED		



TITLE:
CROSS BAR BRACKETS & HARDWARE FOR Qty. 4 8020 CROSS BARS

SIZE B	DWG. NO. 1005-MK05-00-HW REV 0	REV 0
SCALE: NTS		SHEET 1 OF 1

POST PROCESSING: None

FINISH: None

HSLD Flush Mount Solar Panel Bracket

Quantity 2 Total

Flush mount solar panel hardware kit

ITEM NO.	Manufacturer	PART NUMBER	DESCRIPTION	MATERIAL	QTY.
1	Unaka Gear Co.	1001-MB27-01 REV 1	FLUSH MOUNT SOLAR PANEL BRACKET, NARROW	AISI 304	8
2	Unaka Gear Co	1001-MK27-00-HW REV 0	HARDWARE FOR QTY 4 TOP MOUNT OR FLUSH MOUNT PANEL BRACKETS	ASSEMBLY	2

REVISIONS				
ZONE	REV.	DESCRIPTION	DATE	APPROVED
	0	BUMPED REVISION FOR INITIAL RELEASE	7/20/2023	JEO
	1	ADDED 5/16-X 5/8 BHCS AND THREADLOCK NOTE	8/1/2023	JEO
	2	MOVED HARDWARE TO SUB KIT FOR QUANTITY 4 BRACKETS	8/15/2023	JEO

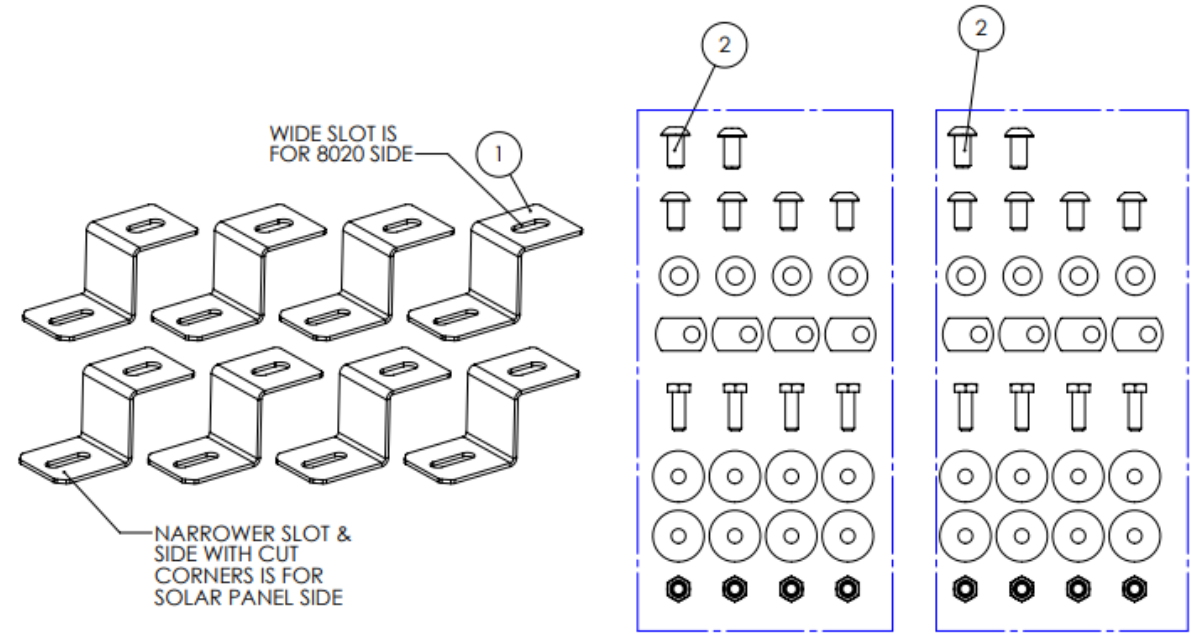

- KITTING NOTES:**
1. LOCKTITE: 5/16-18 BHCS BOLTS SHOULD HAVE THREADLOCK PRE-APPLIED BEFORE BAGGING
 2. PLACE ALL HARDWARE IN A SINGLE LABELED HARDWARE BAG
 3. PLACE BAG OF HARDWARE AND BRACKETS INTO A LABELED BOX
 4. IF LABELED BOX IS NOT AN OPTION, STACK BRACKETS, AND SHRINK WRAP HARDWARE BAG TO BRACKETS

HARDWARE BAGS SHOULD BE LABELED

POST PROCESSING: ASSEMBLY
FINISH: None

<small>UNLESS OTHERWISE SPECIFIED DIMENSIONS ARE IN INCHES</small> TOLERANCES: ANGULAR: ±0.5° ONE PLACE DECIMAL: ±0.1 TWO PLACE DECIMAL: ±0.01 THREE PLACE DECIMAL: ±0.005	DO NOT SCALE DRAWING		TITLE:									
	<table border="1"> <tr> <th>NAME</th> <th>DATE</th> </tr> <tr> <td>---</td> <td>---</td> </tr> </table>	NAME	DATE	---	---	<table border="1"> <tr> <th>DATE</th> <th>NAME</th> </tr> <tr> <td>---</td> <td>---</td> </tr> </table>	DATE	NAME	---	---	FLUSH MOUNT SOLAR PANEL BRACKET, SET OF 8 W/8020 HARDWARE	
NAME	DATE											
---	---											
DATE	NAME											
---	---											
<small>PROPRIETARY AND CONFIDENTIAL</small> THE INFORMATION CONTAINED IN THIS DRAWING IS THE SOLE PROPERTY OF UNAKA GEAR CO. ANY REPRODUCTION IN PART OR AS A WHOLE WITHOUT THE WRITTEN PERMISSION OF UNAKA GEAR CO. IS STRICTLY PROHIBITED.			SIZE B	DWG. NO. 1001-MK27-00 REV 2	REV 2							
	SCALE: NTS		SHEET 1 OF 1									

HSLD Flush Mount Solar Panel Hardware

Quantity 4 Total

Hardware for flush mount solar panel kit

ITEM NO.	Manufacturer	PART NUMBER	DESCRIPTION	MATERIAL	QTY.
1	8020	3678	T-NUT, ECONOMY, 5/16 THREAD, SS	NA	4
2	ANY	90313A107	WASHER, 1/4" X 1" OD, 18-8 SS	NA	8
3	ANY	91831A029	LOCKNUT, 1/4-20, 18-8 S.S.	NA	4
4	ANY	92141A030-BO	FLAT WASHER, 5/16" SCREW SIZE, 0.344" ID, 0.75" OD, 18-8 SS	NA	4
5	ANY	92240A540	HEX BOLT, 1/4-20 X 0.75" FULLY THREADED, 18-8 S.S.	NA	4
6	ANY	92949A580-BO	BHCS, 5/16-18 X 5/8" LG, FULL THREAD, 18-8 SS	NA	2
7	ANY	92949A853-BO	BHCS, 5/16-18 X 0.5625" LG, FULLY THREADED, 18-8 S.S.	NA	4

REVISIONS				
ZONE	REV.	DESCRIPTION	DATE	APPROVED
	0	CREATED REV 1 FOR REVISION CONTROL.	8/2/2023	JEO

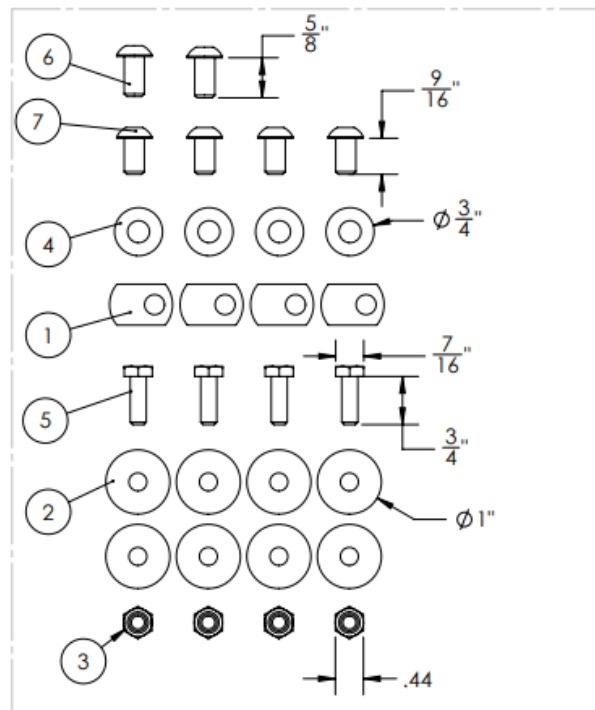

ASSEMBLY NOTES: ITEM 6 IS ONLY USED WHEN TWO BRACKETS ARE BEING BOLTED ON TOP OF EACH OTHER

- KITTING NOTES:**
- LOCKTITE: ITEMS 6 AND 7 SHOULD HAVE THREADLOCK PRE-APPLIED BEFORE BAGGING
 - PLACE ALL HARDWARE IN A SINGLE LABELED HARDWARE BAG

PLACE ALL HARDWARE IN A BAG, LABEL BAG 1001-MK27-00-HW "HARDWARE FOR SET OF 4 TOP MOUNT OR FLUSH MOUNT BRACKETS)

UNLESS OTHERWISE SPECIFIED DIMENSIONS ARE IN INCHES		DO NOT SCALE DRAWING		TITLE:	
TOLERANCES:		NAME	DATE	HARDWARE FOR QTY 4 TOP MOUNT OR FLUSH MOUNT PANEL BRACKETS	
ANGULAR: ±0.5°		DRAWN	---	SIZE	DWG. NO.
ONE PLACE DECIMAL: ±0.1		CHECKED	---	B	1001-MK27-00-HW REV 0
TWO PLACE DECIMAL: ±0.01				SCALE: NTS	REV
THREE PLACE DECIMAL: ±0.005					0
PROPRIETARY AND CONFIDENTIAL				SHEET 1 OF 1	
THE INFORMATION CONTAINED IN THIS DRAWING IS THE SOLE PROPERTY OF UNAKA GEAR CO. ANY REPRODUCTION IN PART OR AS A WHOLE WITHOUT THE WRITTEN PERMISSION OF UNAKA GEAR CO. IS STRICTLY PROHIBITED.					

POST PROCESSING: ASSEMBLY
FINISH: None

End Cap Hardware

End cap hardware kit

ITEM NO.	Manufacturer	PART NUMBER	DESCRIPTION	MATERIAL	QTY.
1	8020	203001-PLAIN	END CAP, 15 SERIES, PLAIN, BLACK	NA	2
2	8020	3267	SELF TAPPING END CAP SCREW, M7 X 0.36"	NA	2

REVISIONS				
ZONE	REV.	DESCRIPTION	DATE	APPROVED
	0	BUMPED REVISION FOR REV CONTROL	10/26/2023	JEO

Quantity 1 Total

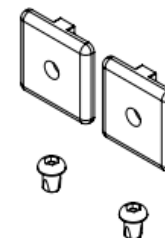
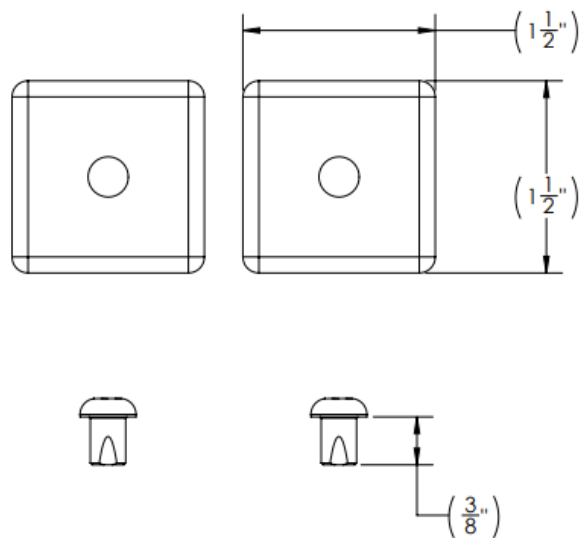

NOTES:

1. PLACE END CAPS AND SELF TAPPING SCREWS IN A SINGLE BAG
2. APPLY SKU LABEL TO OUTSIDE OF BAG

UNLESS OTHERWISE SPECIFIED DIMENSIONS ARE IN INCHES

TOLERANCES:
 ANGULAR: ±0.5°
 ONE PLACE DECIMAL: ±0.1
 TWO PLACE DECIMAL: ±0.01
 THREE PLACE DECIMAL: ±0.005

PROPRIETARY AND CONFIDENTIAL
 THE INFORMATION CONTAINED IN THIS DRAWING IS THE SOLE PROPERTY OF UNAKA GEAR CO. ANY REPRODUCTION IN PART OR AS A WHOLE WITHOUT THE WRITTEN PERMISSION OF UNAKA GEAR CO. IS STRICTLY PROHIBITED.

DO NOT SCALE DRAWING		
NAME	DATE	
DRAWN BY JEO	---	
CHECKED	---	



TITLE:
 8020 STYLE 15 SERIES END CAPS, SET OF 2

SIZE **B** DWG. NO. 1005-MK08-00 REV 0 REV **0**

SCALE: NTS SHEET 1 OF 1

POST PROCESSING: None
 FINISH: None

Installation Overview

1. Layout and identify all parts
 - Keep hardware separate, some types may be only slightly different and are not interchangeable
2. Assemble side rail assemblies
 - Add additional hardware to top of extrusion slot as needed for flush mount solar panel brackets or other accessories
3. Assemble cross bar assemblies
 - Add additional hardware to top of extrusion slot as needed for flush mount solar panel brackets or other accessories
4. Assemble wind fairing
5. Loosely install rack brackets on the van t-studs
6. Loosely install side rails onto roof rack brackets on van
7. Loosely install cross bars on rack
8. Loosely install wind fairing to rack side rails
9. Use cross bars and wind fairing to set the spacing of the side rails, ensuring they are parallel
10. Snug up cross bar and wind fairing hardware making rack fairly uniform
11. Tighten and torque bolts securing rack to rack brackets
12. Loosening and adjust cross bar positions as needed, install solar panels, and re-tighten everything
13. Torque all hardware

Extrusion T-Nut Installation Overview: Part # 3678 or similar

1. T-nuts are used to connect 8020 style extrusion and other components
2. When installing T-nuts, leave the flat side towards the outside of the extrusion, and have the boss facing the center of the extrusion
3. Once inside the extrusion, slide the t-nut to the desired location

Correct way to Orient T-nuts when sliding into extrusion

T-Nut Boss faces
center of extrusion

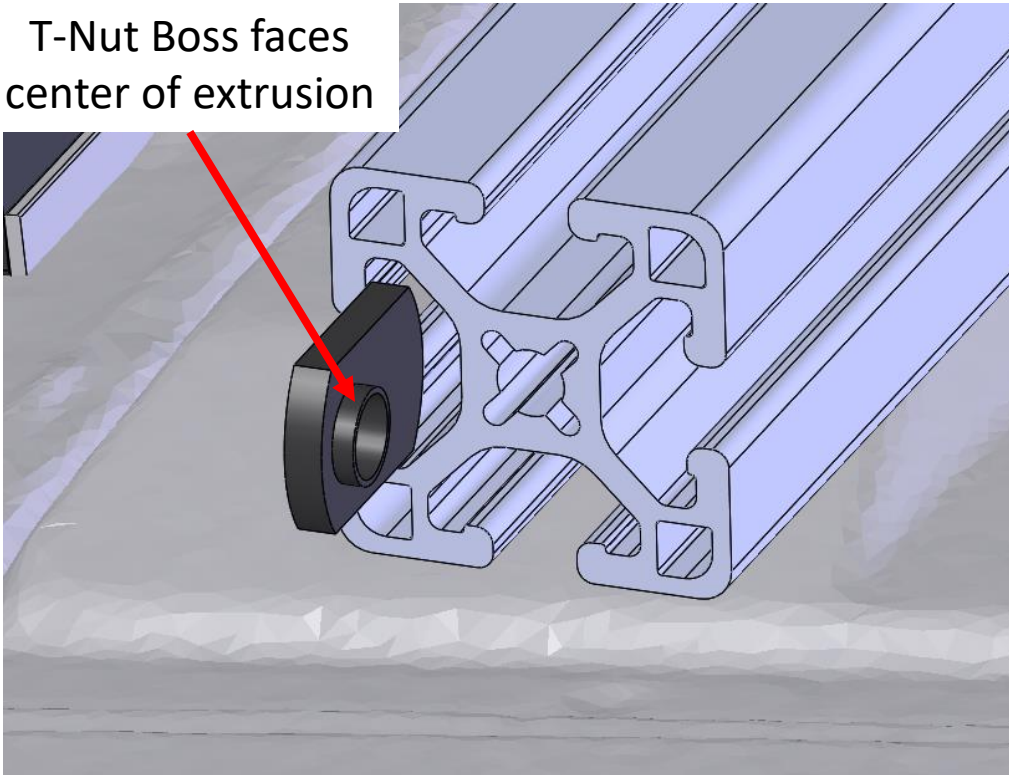

Extrusion T-Nut Installation Overview: Part # 3678 or similar

1. One side of the t-nut is longer than the other so installation orientation is critical
2. Note, the example below is just one portion of the rack shown as an example, but the same principle may apply to other locations
3. When the long side is pointed at the long side of another t-nut, in some cases they can physically interfere
4. When the long side is pointed at the end of the extrusion, in some cases they can extend past, and physically prevent 1 piece from correctly touching the other
5. In most cases if a t-nut creates an interference, reversing its orientation will solve the issue

Correct way to Orient T-nuts to prevent interferences

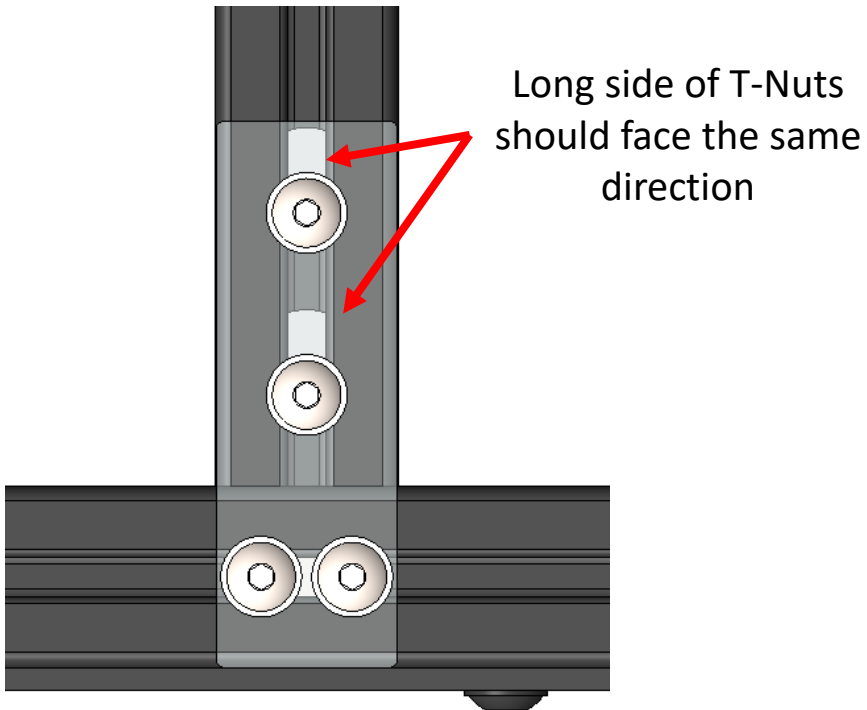

Warning: T-nuts installed in the orientation below will create interferences

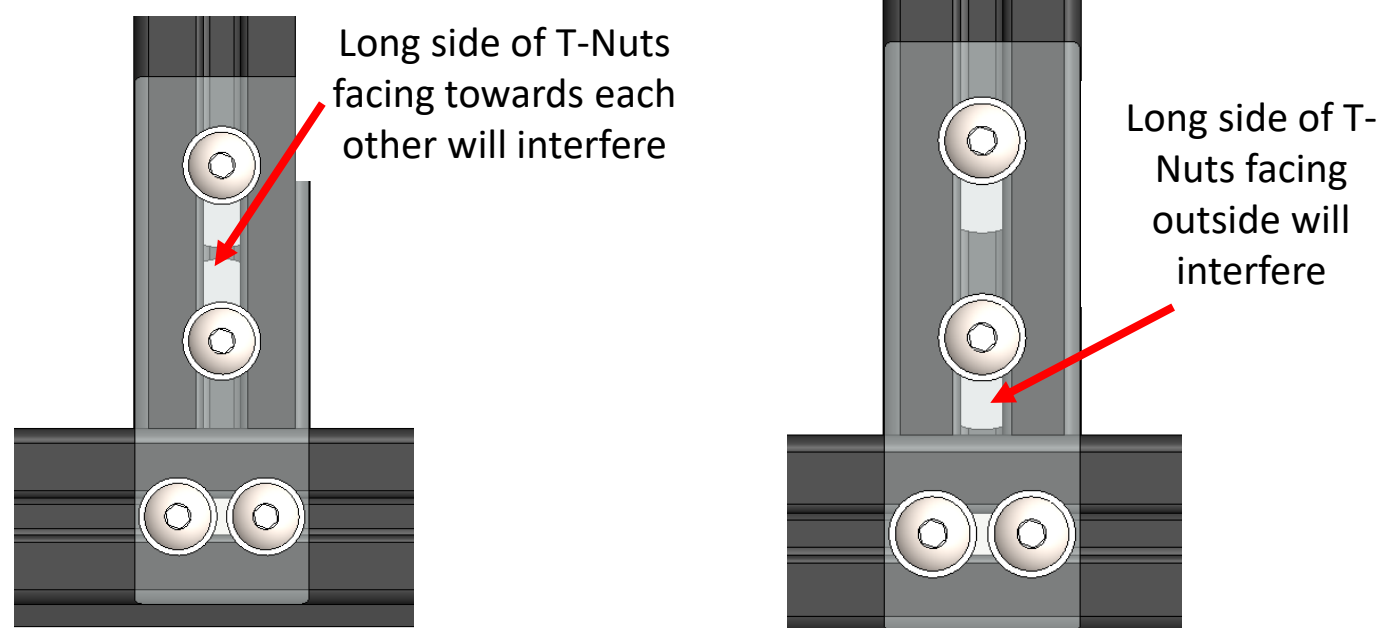

Long side of actual t-nuts is longer than shown in the image and will interfere

159" WB Side Rail Assembly:

This section covers the HSLD side rail assembly. Note the images shown are for the Driver side assembly. The passenger side assembly is a mirrored image.

Below is the bill of material (BOM) for Qty 1 side rail assembly. The BOM for the driver side, and passenger side rail assemblies are identical and match the table below.

ITEM NO.	Manufacturer	PART NUMBER	DESCRIPTION	MATERIAL	QTY.
1	8020	203001-PLAIN	END CAP, 15 SERIES, PLAIN, BLACK	NA	1
2	8020	3267	SELF TAPPING END CAP SCREW, M7 X 0.36"	NA	1
3	Any	3607	BHCS, FLANGED, 5/16 X 0.687" LG., S.S., BLACK	NA	4
4	ANY	3678	T-NUT, ECONOMY, 5/16 THREAD, SS	NA	22
5	ANY	92141A030	FLAT WASHER, 5/16" SCREW SIZE, 0.344" ID, 0.75" OD, 18-8 SS	NA	18
6	ANY	92949A853-BO	BHCS, 5/16-18 X 0.5625" LG, FULLY THREADED, 18-8 S.S.	NA	17
7	ANY	92949A854-B	BHCS, 5/16-18 X 1-1/8" LG, FULLY THREADED, 18-8 S.S., BLACK	NA	1
8	Unaka Gear Co.	1001-MB50-01 REV 1	RAM PROMASTER FRONT SIDE PLATE	5052-H32	1
9	Unaka Gear Co.	1001-MB50-02 REV 1	RAM PROMASTER REAR SIDE PLATE	5052-H32	1
10	Unaka Gear Co.	1001-MB50-03 REV 0	RAM PM 0.25" SIDE PLATE SPACER	5052-H32	10
11	Unaka Gear Co.	1001-MB50-04 REV 1	RAM 159 NON EXT SPLICE SIDE PLATE	5052-H32	1
12	Unaka Gear Co.	1001-MP12-01 REV B	PROMASTER ROOF RACK BRACKET 8020 ADAPTER	5052-H32	4
13	Unaka Gear Co.	1005-MB01-01 REV 2	STRAIGHT FLAT PLATE, 15 SERIES, 4 HOLE	6061 Alloy	1
14	Unaka Gear Co.	1515-UL-BLACK-64	8020 Style Extrusion, 15 Series, Ultra Lite, Grooved, Black, 64" LG.	6061 Alloy	1
15	Unaka Gear Co.	1515-UL-BLACK-83.44	8020 Style Extrusion, 15 Series, Ultra Lite, Grooved, Black, 81.56" LG.	6061 Alloy	1

159" WB Side Rail Assembly:

Driver Side HSLD Side Rail

- REQUIRED TOOLS:**
- MEASURING TAPE
 - 3/16" ALLEN WRENCH
 - BLUE LOCTITE 242

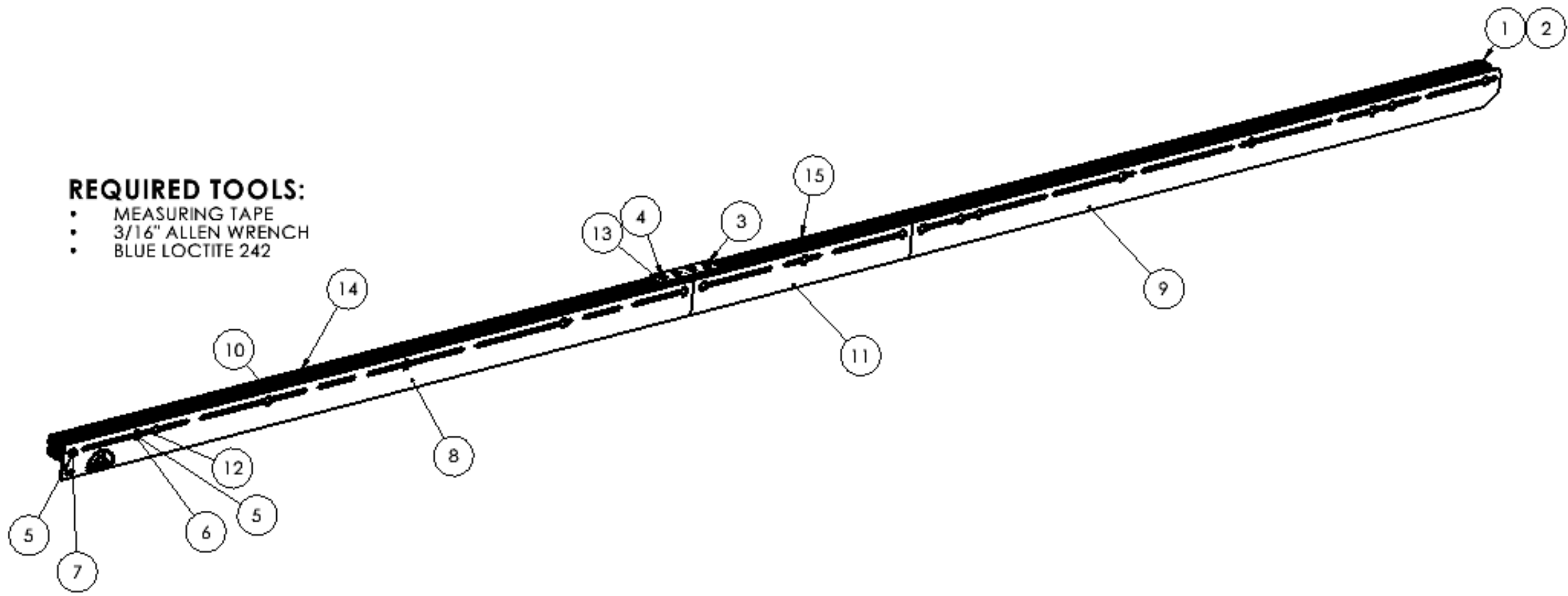

159" WB Side Rail Assembly:

Driver Side HSLD Side Rail

ASSEMBLY STEPS:

1. LAYOUT PARTS, ENSURE SIDE PLATE ITEMS (8), (9), (11) AND 8020 ADAPTER BRACKETS (12) ORIENTATIONS ARE CORRECT FOR THE SIDE RAIL YOU ARE ASSEMBLING
2. FOR PASSENGER SIDE RAIL ASSEMBLY, LAYOUT PARTS TO ENSURING YOU WILL BE CREATING AN OPPOSITE HAND VERSION TO THE DRIVER SIDE ASSEMBLY SHOWN BELOW.
3. DO NOT INSTALL END CAPS ITEM (1) AND (2) AT THIS TIME. THEY WILL BE INSTALLED AFTER ALL T-NUTS FOR THE CROSS BARS ARE INSTALLED
4. ALL SIDE RAIL SPACERS EXCEPT THE FIRST ONE GET SECURED USING BHCS (6). THE FIRST SPACER GETS BHCS (7) WHICH WILL BE USED TO SECURE THE WIND FAIRING TO THE SIDE RAIL ASSEMBLY

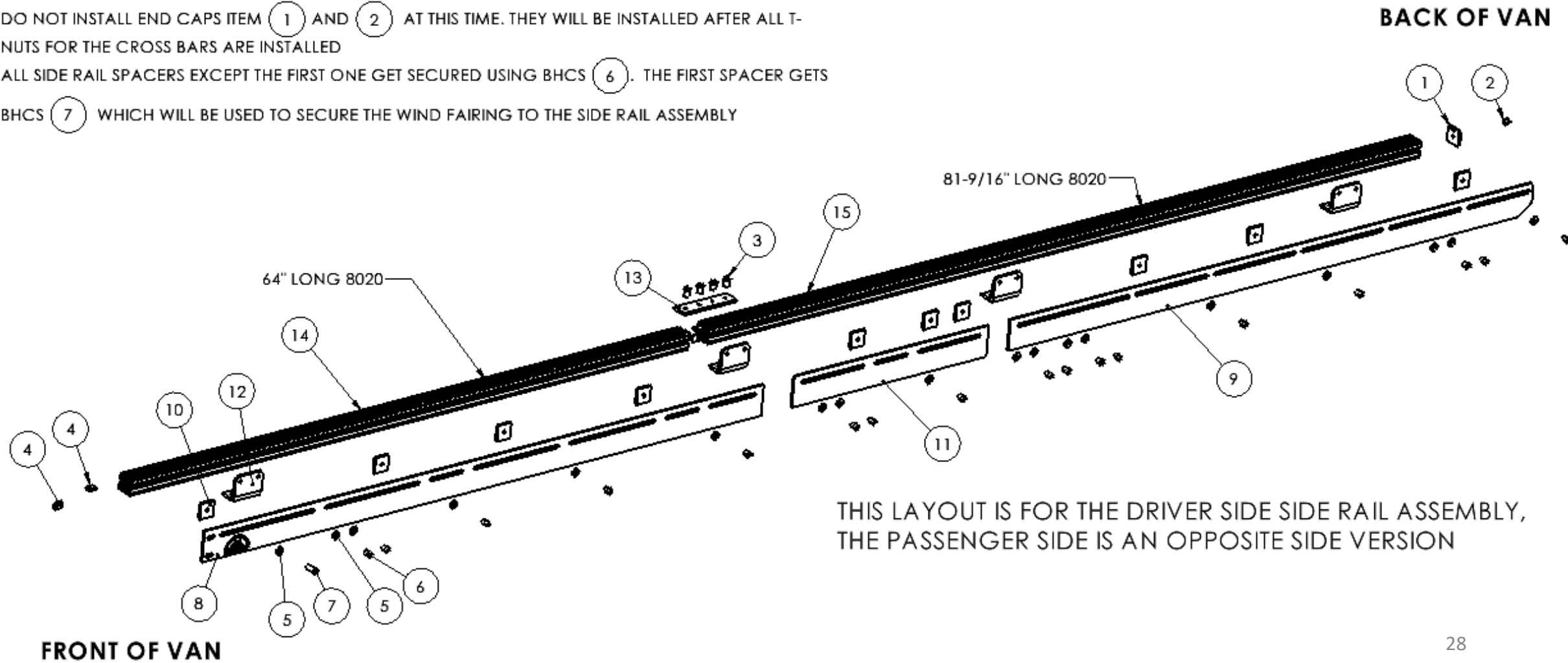

159" WB Side Rail Assembly:

Driver Side HSLD Side Rail

STEP 2 - 4: JOIN FRONT AND REAR 8020 WITH 4 HOLE SPLICE PLATE (13) APPLYING BLUE LOCTITE 242 TO BOLTS (3) BEFORE INSERTING



STEP 5: SLIDE QTY 18 T-NUTS (4) INTO FRONT OF 8020, POSITION BOLT HOLE TO DIMENSIONS BELOW

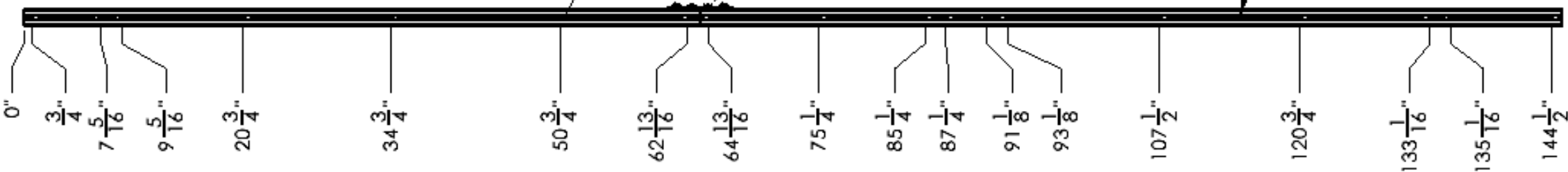

STEP 6: PLACE 1/4" SPACERS ITEM 10 AND 8020 ADAPTERS (12) OVER T-NUTS IN THE LOCATIONS SHOWN BELOW



159" WB Side Rail Assembly:

Driver Side HSLD Side Rail

STEP 6: PLACE 1/4" SPACERS ITEM 10 AND 8020 ADAPTERS (12) OVER T-NUTS IN THE LOCATIONS SHOWN BELOW

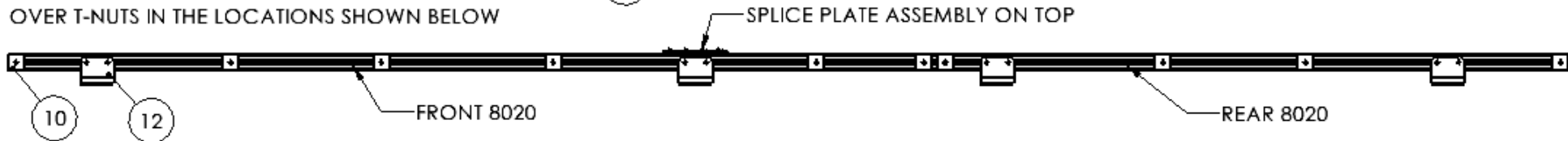

STEP 7: ALIGN FRONT SIDE PLATE (8) WITH FRONT OF 8020. PLACE WASHER (5) ONTO BHCS (6), APPLY BLUE LOCTITE 242 TO SIDE OF BHCS (6), SECURE SIDE PLATES TO 8020 RAIL GOING THROUGH THE SIDE PLATE SLOTS, SPACERS / 8020 ADAPTERS, AND INTO THE T-NUTS (4) ALREADY POSITIONED IN THE 8020. DO NOT FULLY TIGHTEN BOLTS GOING INTO THE LAST THREE 8020 ADAPTERS AT THIS TIME, POSITION THE LEADING EDGE OF THE 8020 ADAPTER TO THE DIMENSIONS BELOW, AND SNUG UP AS THESE MAY NEED TO BE ADJUSTED TO MATCH ROOF RACK BRACKETS

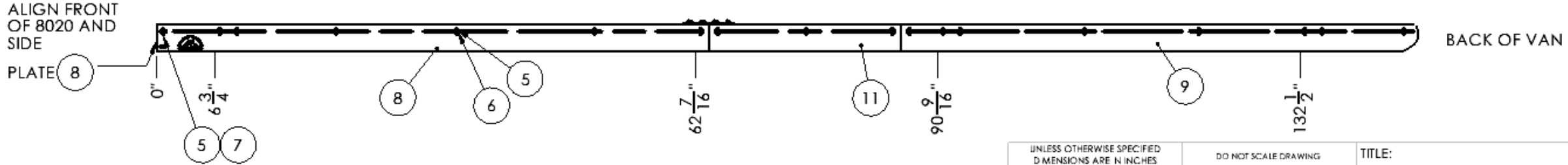

NOTE: BHCS (7) IS USED TO SECURE THE WIND FAIRING TO THE 8020, DO NOT ATTEMPT TO FULLY TIGHTEN, DO NOT APPLY LOCTITE TO THIS BOLT UNTIL INSTALLING WIND FAIRING ON VAN

POST PROCESSING: Assembly
FINISH: None

UNLESS OTHERWISE SPECIFIED DIMENSIONS ARE IN INCHES TOLERANCES: ANGULAR: ±0.5° ONE PLACE DECIMAL: ±0.1 TWO PLACE DECIMAL: ±0.01 THREE PLACE DECIMAL: ±0.005	DO NOT SCALE DRAWING		TITLE: RAM PROMASTER 159 NON EXT HSLD SIDE RAIL ASSEMBLY
	DRAWN BY: JEO	NAME: --	
PROPRIETARY AND CONFIDENTIAL THE INFORMATION CONTAINED IN THIS DRAWING IS THE SOLE PROPERTY OF UNAKA GEAR CO. ANY REPRODUCTION IN PART OR AS A WHOLE WITHOUT THE WRITTEN PERMISSION OF UNAKA GEAR CO. IS STRICTLY PROHIBITED.	CHECKED: --		SIZE: B
			DWG. NO.: 1001-MA51-01 REV 1
SCALE: NTS			REV: 1

Cross Bar Initial Assembly: Standard kit comes with Qty 4 cross bars, additional bars can be purchased separately

ITEM NO.	Manufacturer	PART NUMBER	DESCRIPTION	MATERIAL	QTY.
1	Unaka Gear Co.	1515-UL-BLACK-56.75	1515-UL-BLACK-56.75	6061 Alloy	1
2	8020	3607	BHCS, FLANGED, 5/16 X 0.687" LG., S.S.	NA	8
3	8020	3678	T-NUT, ECONOMY, 5/16 THREAD, SS	NA	4
4	Unaka Gear Co.	1005-MB03-01 REV 0	STRAIGHT FLAT PLATE, 15 SERIES, 4 HOLE	6061 Alloy	2
5	Unaka Gear Co.	1005-MP00-01 REV 0	DOUBLE T-NUT, 15 SERIES, ECONOMY, 5/16-18 THREAD, SS	AISI 304	2

REQUIRED TOOLS:

- 3/16" ALLEN WRENCH
- BLUE LOCTITE 242

ASSEMBLY STEPS:

1. SLIDE ANY T-NUTS INTO TOP OF 8020 REQUIRED FOR FLUSH MOUNT SOLAR PANEL BRACKETS OR OTHER ACCESSORIES. NOTE THESE ADDITIONAL T-NUTS ARE NOT PROVIDED WITH THIS CROSS BAR ASSEMBLY
2. SLIDE QTY 2 ITEM (3) INTO TOP OF BOTH ENDS OF 8020, APPLY BLUE LOCTITE 242 TO SIDE OF BOLT (2), USE BOLT TO SECURE THE NARROW BRACKETS (4) TO TOP OF 8020. SNUG BOLTS UP ONLY IN CASE BRACKET NEEDS TO BE ADJUSTED WHEN INSTALLED ON VAN RACK
3. REMAINING QTY 4 OF BHCS AND T-NUTS WILL BE USED TO SECURE THIS CROSS BAR TO THE RACK SIDE RAIL ASSEMBLY ON THE ROOF OF THE VAN
4. WHEN SECURING CROSS BAR TO 8020 SIDE RAIL ON ROOF OF VAN, PLACE BLUE LOCTITE 242 ON SIDE OF BOLT BEFORE INSERTING IT THROUGH BRACKET AND INTO T-NUT

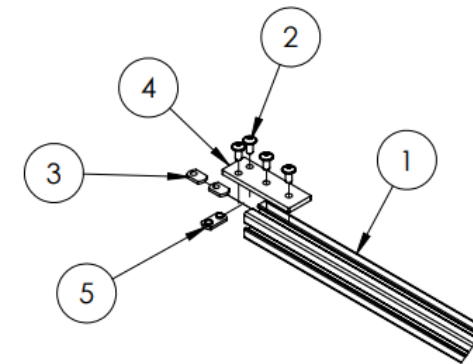
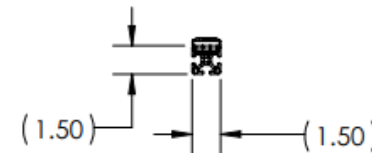
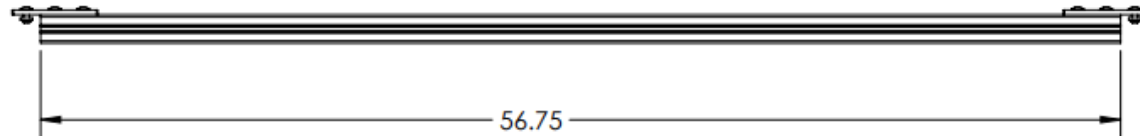
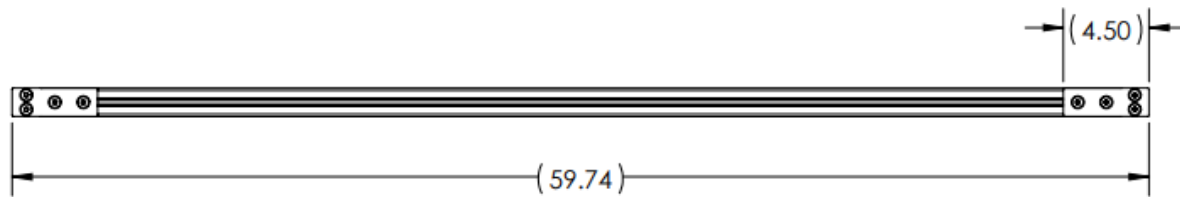
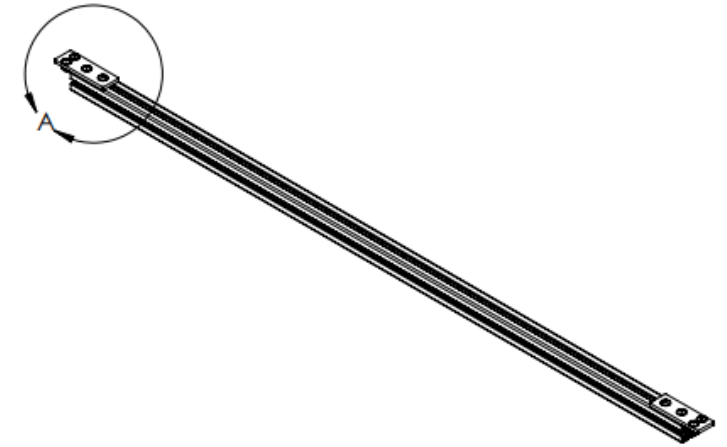

DETAIL A
SCALE 1 : 4

Cross Bar Initial Assembly:

1. If you haven't done so, double check to see if any other parts in future steps will need to be attached to your cross bars and how many t-nuts will be required for each item. This includes flush mount solar panel brackets, other 8020 brackets, the tie downs, etc.
2. Install the brackets required to secure your cross bar to the side rails. The Unaka standard option is the flat narrow 4 hole brackets which each use 4 bolts and t-nuts. Other options include using cross bars that use 4 x 2 hole corner brackets, 5 hole L brackets, or your own custom solution.
3. Do not fully tighten the hardware at this time. Leave at least one or two pieces of hardware tight enough where the brackets won't come loose and slide off the end of the extrusion while lifting and lower the cross bars into place.
4. If cross bar assemblies include different quantities of hardware for different accessories, mark them so that they get installed in the correct order or location on the roof rack

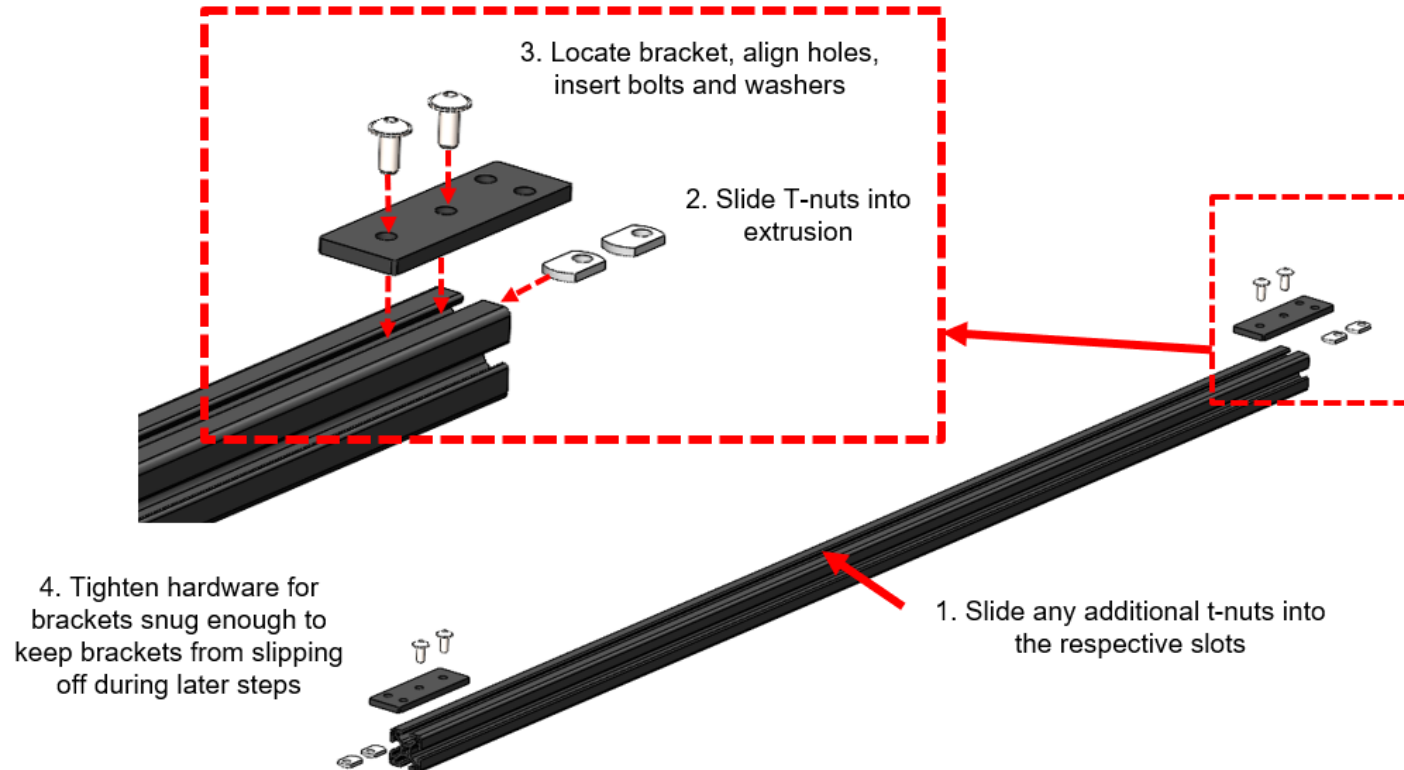

Assemble Wind Fairing End Caps

1. Apply anti-seize to all bolts in this step during installation
2. Warning: Top and bottom end cap brackets look very similar, but they have identifying notches. Lower bracket has 3 notches, upper bracket has 2 notches.
3. End cap brackets should be installed with the tab with the chamfered corners bolting to wind fairing end cap
4. Bolt top and bottom wind fairing brackets to driver side end cap. ***Leave the bolts just loose enough so the brackets can float around in their slots
5. Repeat process for passenger side end cap

Driver Side End Cap Assembled

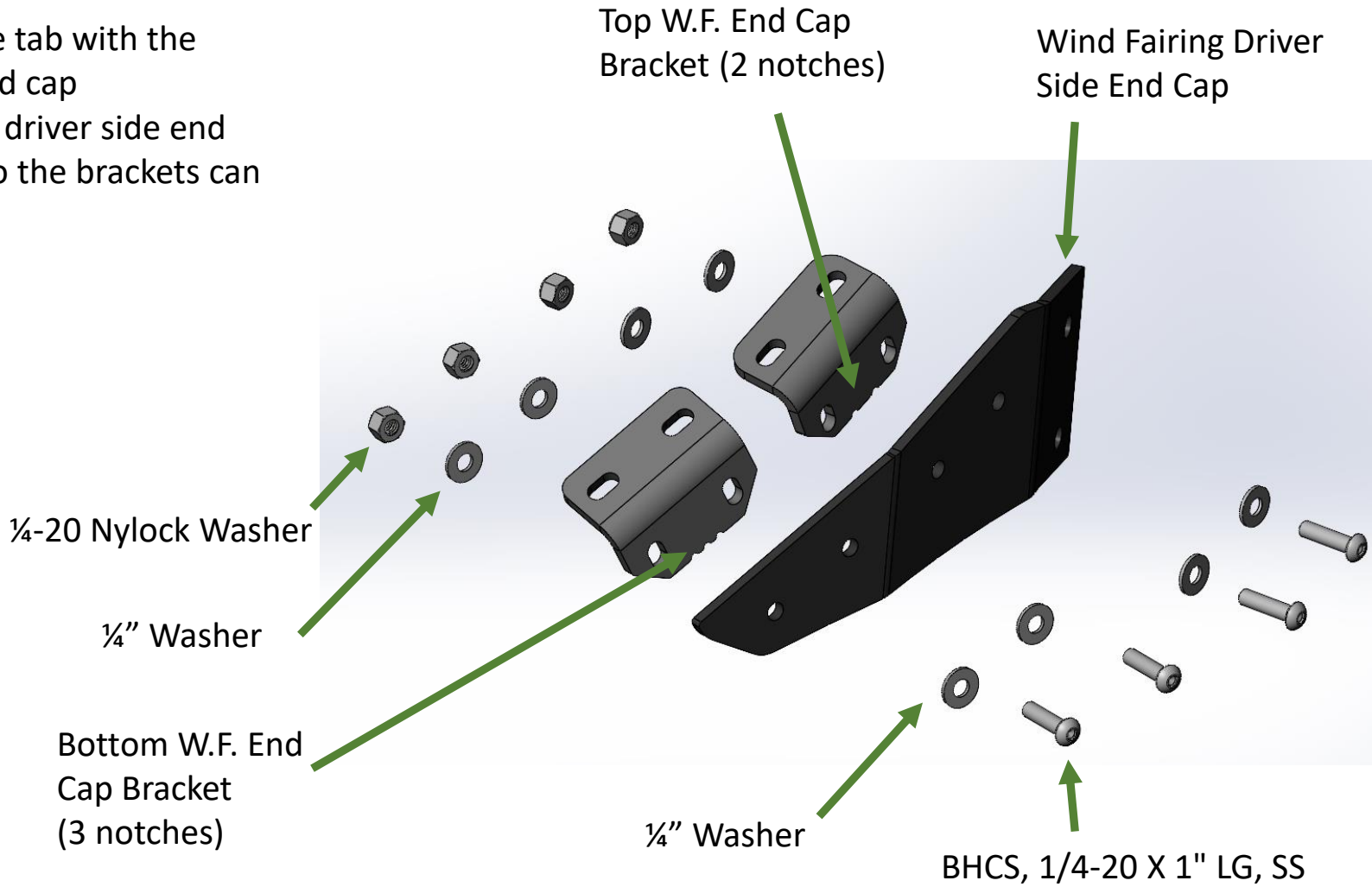
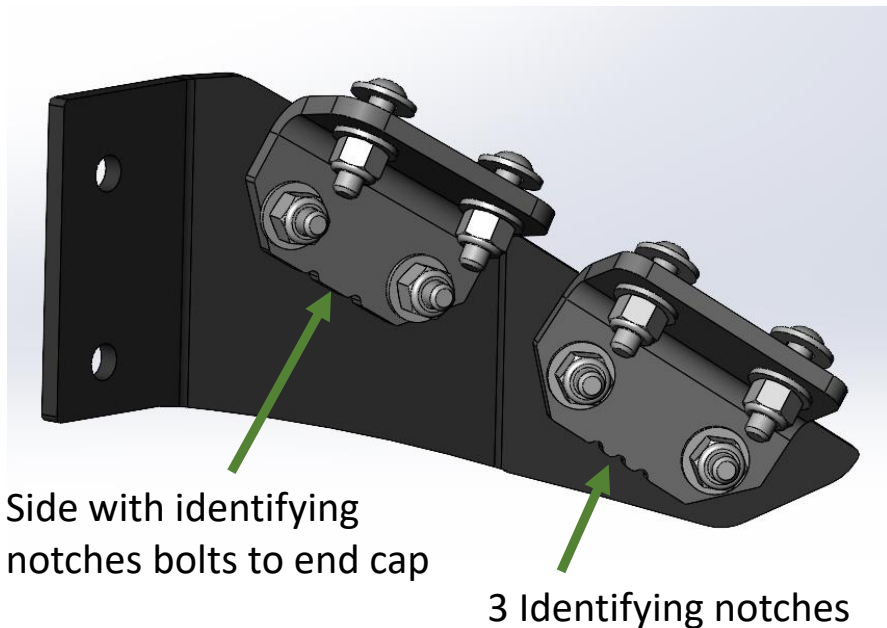

Bolt wind fairing to end caps

1. Apply anti-seize to all bolts in this step during installation
2. Hardware holding end cap brackets to the end cap still slightly loose
3. Loosely bolt the wind fairing to the wind fairing end cap assemblies
4. ****Tighten the hardware carefully. Do not tighten hardware one at a time. Holding / position the wind fairing to align the edges of the fairing with the end cap as best you can. All edges may not be perfectly aligned due to manufacturing tolerances. Move between the bolts tightening them each a bit slowly until everything is nice and tight. If you tighten one bracket to much, it may not allow the adjustment slots in the brackets to compensate for manufacturing and installation tolerances. All 1/4"-20 hardware on the wind fairing to be tightened to 75 in-lbs (8.5 N-m).**
5. Repeat for the passenger side end cap
6. Install the bulb seal on the front edge of the wind fairing

Completed passenger side end cap / wind fairing

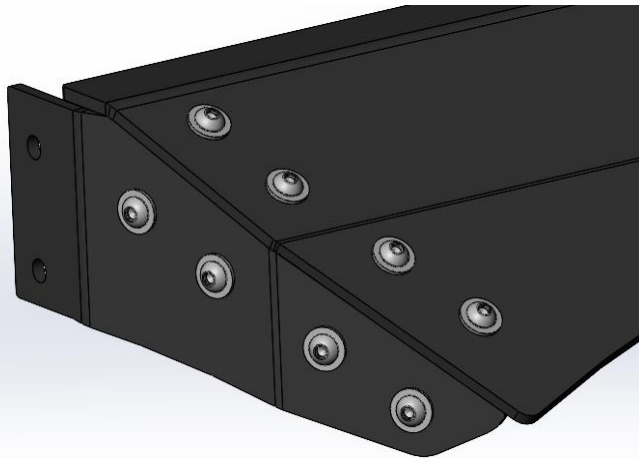

BHCS, 1/4-20 X 1" LG, SS

1/4" Washer

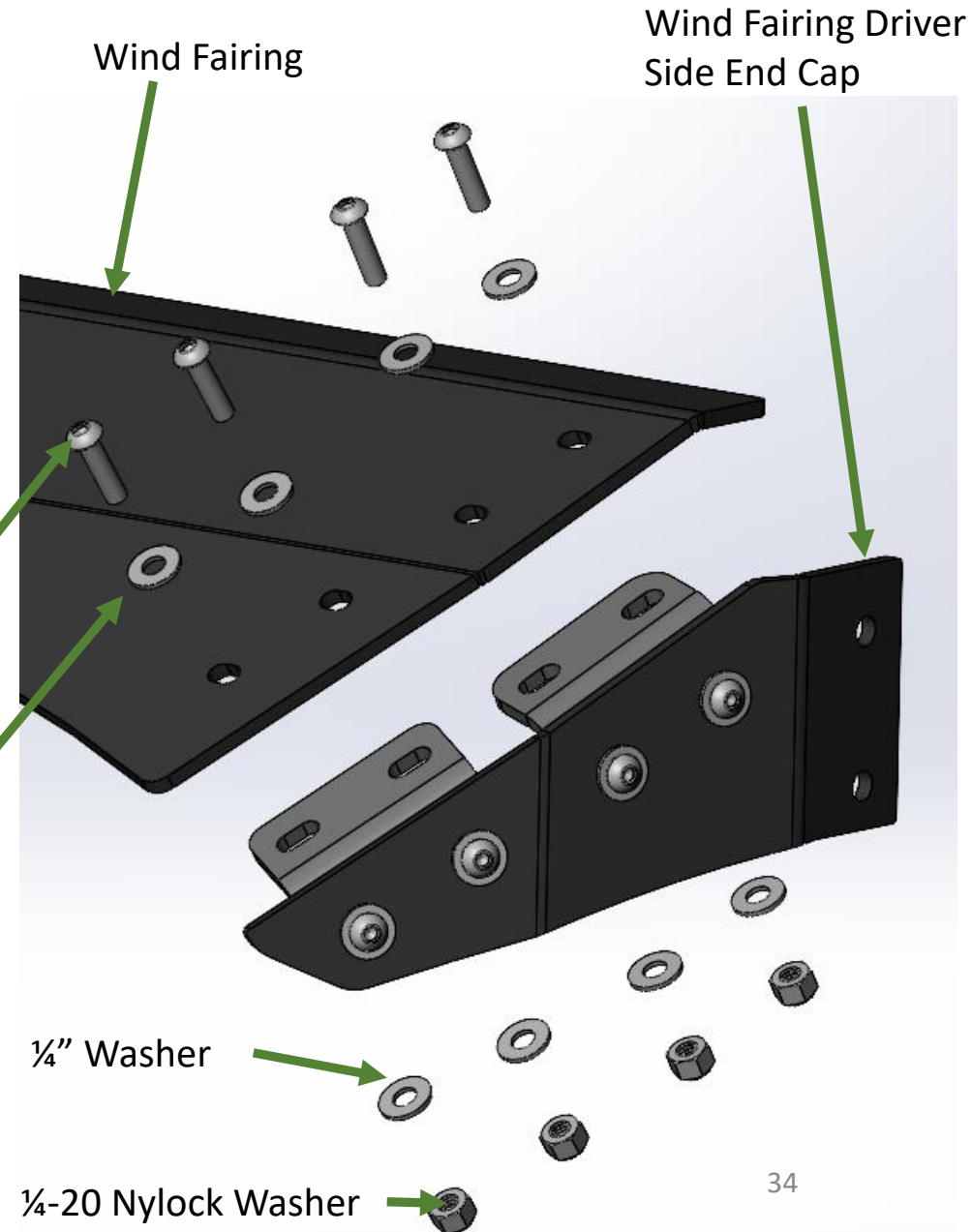

Install Rack Brackets Onto Van

1. Each side of the van gets the following brackets:
 - a) 136" WB: 3 bracket assemblies per side
 - b) 159" WB: 4 bracket assemblies per side
 - c) 159" WB EXT: 5 bracket assemblies per side
2. Locate and install the rack brackets onto the Promaster t-studs.
3. Do not install hardware yet. Leave the 5/16 bolts and washers next to each bracket

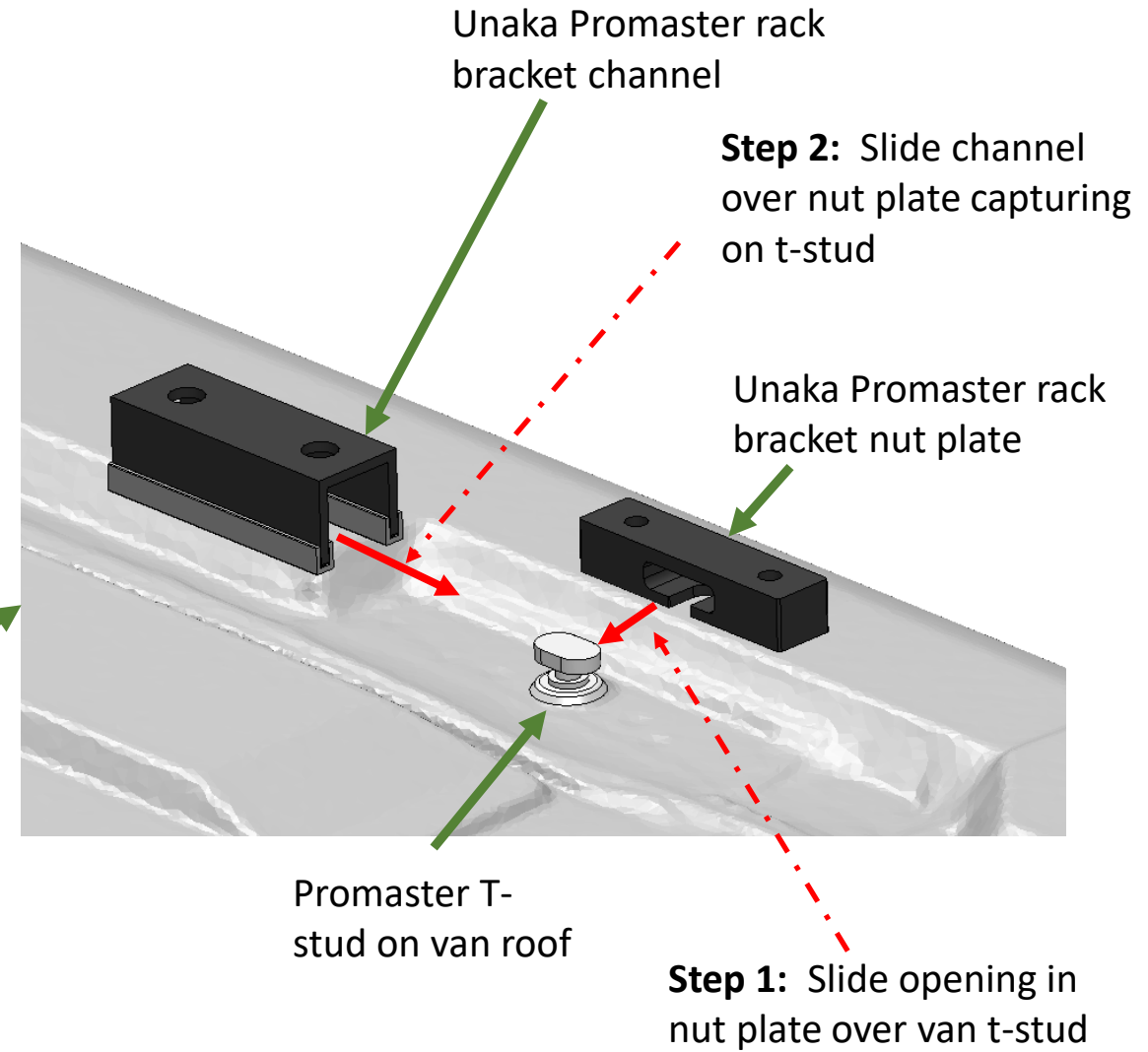
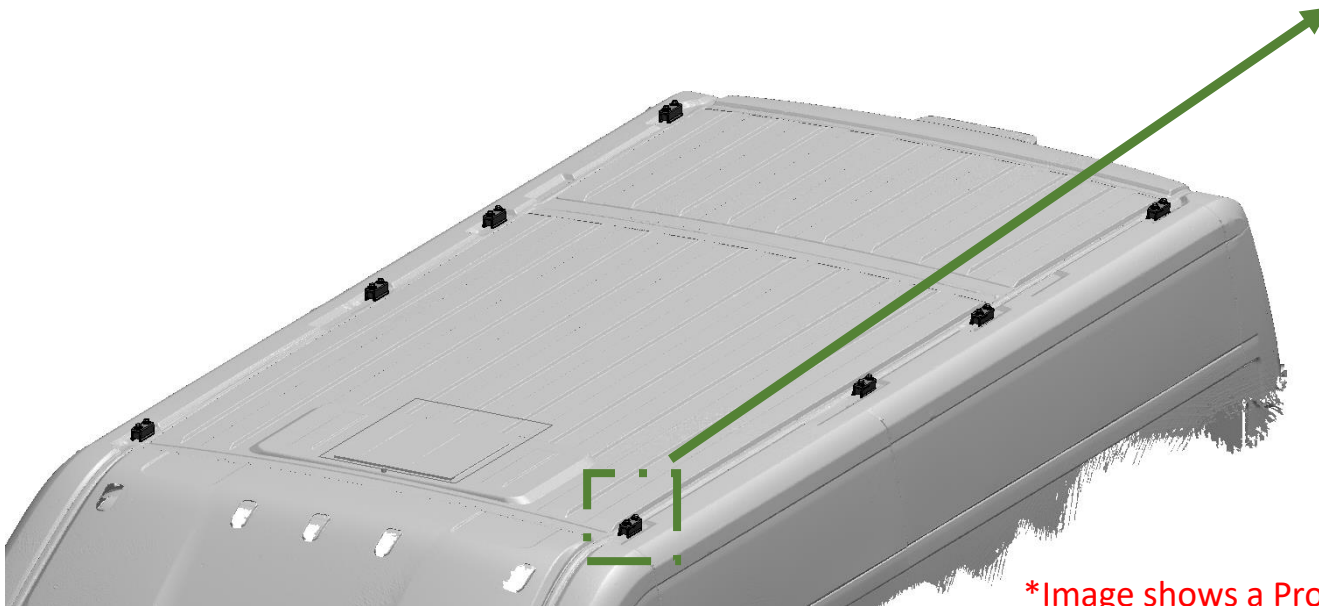
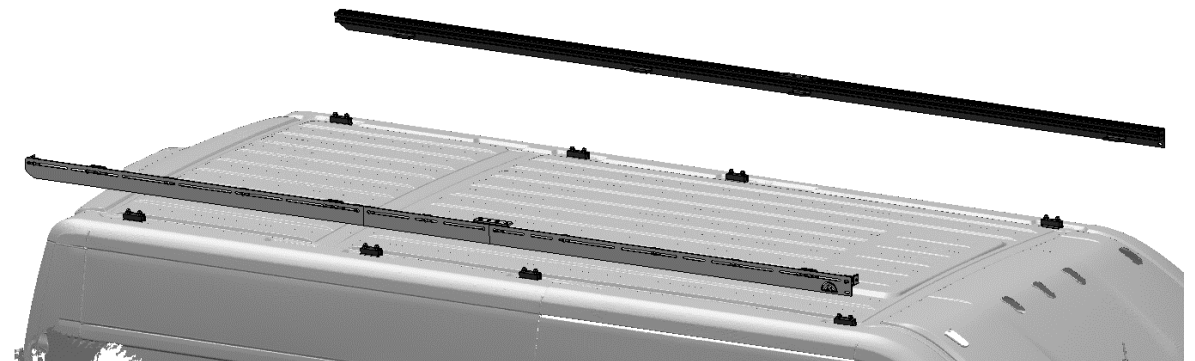
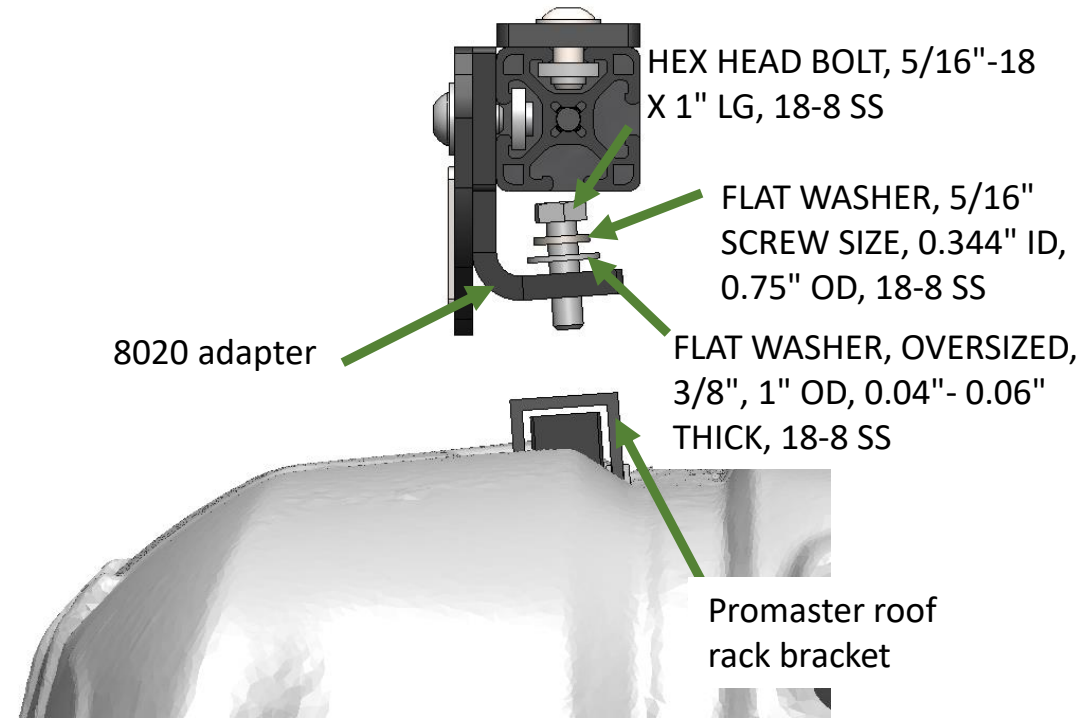

*Image shows a ProMaster 159" WB

Loosely Install Side Rail Assemblies

1. Install 1 side rail assembly at a time using 2 people
2. Lower the side rail assembly onto the roof rack brackets
3. Insert the hex bolt through both washers, apply a dab of Loctite 242 to the side of the bolt, and maneuver it through the 8020 adapter, and into the rack bracket nut plate
4. Turn the first bolt until it just starts to thread in (if you thread it to far you may have a hard time engaging the 2nd bolt)
5. Install the 2nd bolt until following the steps above until it just starts to thread in. If you have trouble, you can loosen the first bolt a touch or try to lift on the nut plate to help it engage.
6. Snug both bolts up evenly but do not tighten yet

NOTE: The dimensions we set the rear three 8020 adapters to during the side rail assembly should be close but may not be perfect for every van. You may need to loosen some of the 8020 adapters and reposition to get the holes to line up with the rack bracket / nut plate.



*Image shows a ProMaster 159" WB

Position Side Rail Assemblies

1. The side rail position with respect to the first 8020 adapter should have been set during the side rail assembly process
2. Confirm that both driver and passenger side rail assemblies are 6.75" in front of the leading edge of the 8020 adapter after they are installed.
3. If they are not, loosen the hardware securing the side plates to the 8020 adapters (not spacer plates), slide the side rail assembly forward or back until 6.75" is achieved, then tighten everything back down. All 5/16"-18 hardware on the side plates to be tightened to 132 in-lbs (15 N-m).

Position the front of each side rail assembly so that it is 6.75" in front of the leading edge of the 8020 adapter.

Leading edge of first 8020 adapter

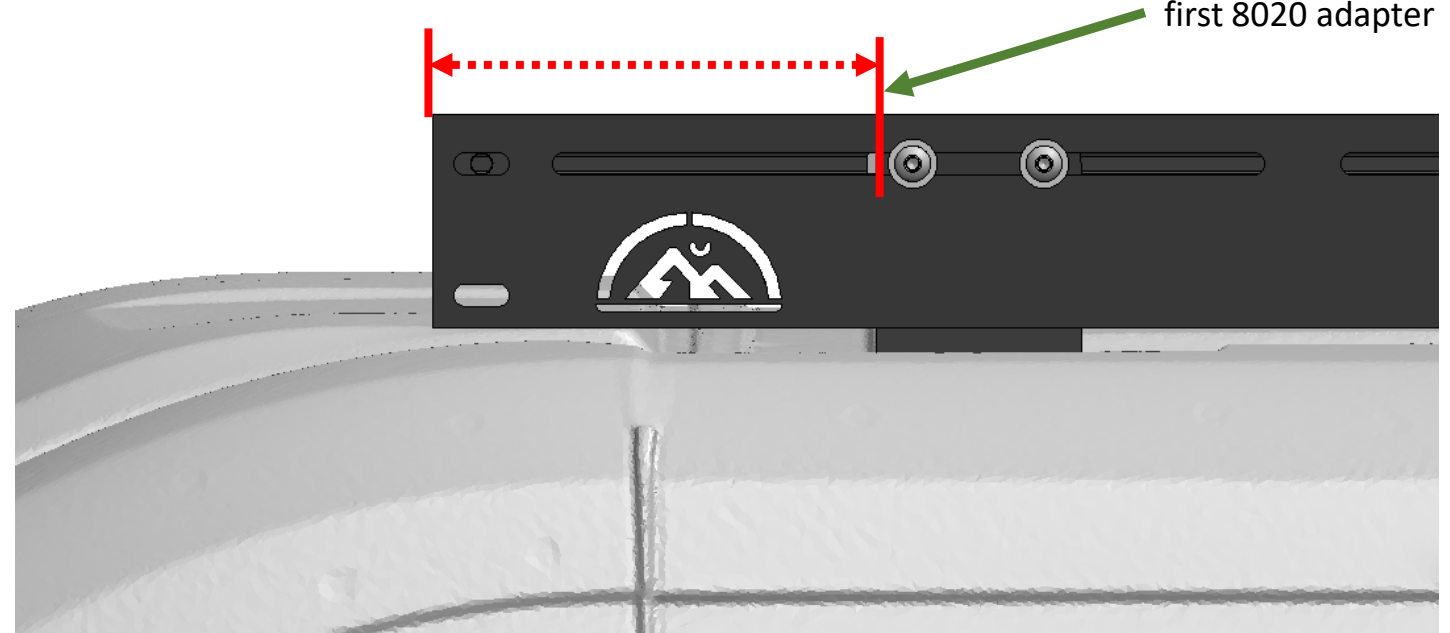

Loosely Install Cross Bar Assemblies

1. Rough position your cross bars in their desired locations. In order to set the side rail to rail spacing in a later step, you will need at least one towards the front, one towards the middle, and one towards the back even if you move them based on your design needs later.
2. Slide 2 t-nuts into the top of each side rail assembly for each cross-bar bracket.
3. Some of these t-nuts will need to be installed from the front, and others from the back. Unless you remove the splice plate you will not be able to install all t-nuts from the front or back.
4. Now is also a good time to add any additional t-nuts into the top of your 8020 side rails that you may need for other accessories (awnings, etc.). Even if you get them close and have to remove one cross-bar bracket to re-position the bolts past it, at least you won't have to remove all of them.
5. In some cases, your 4 hole splice plate may interfere with your desired cross bar location. If this is the case, slide the 4 hole splice plate more to one side.
6. Lower your cross bars onto the 8020 side rails, apply Blue Loctite 242 to the sides of the hardware provided with the cross-bar assemblies, and thread them into the installed t-nuts. Do not fully tighten.

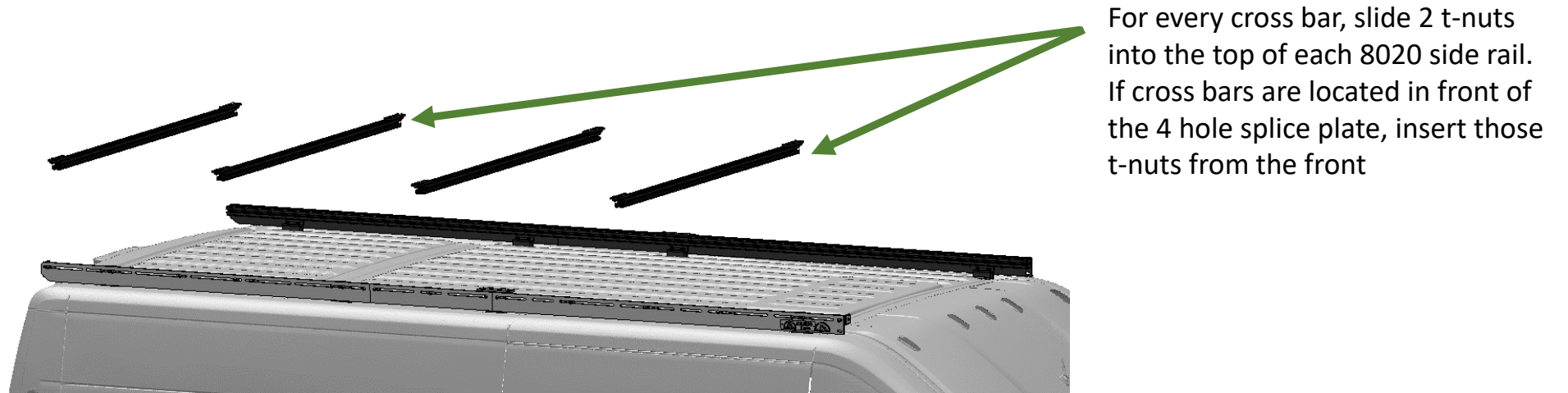

Loosely Install Wind Fairing Assembly

This step should be completed with 2 people using 2 ladders

Tip: Use rags as needed to protect the van if you need to sit the wind fairing on the van roof

Warning: Take extra precautions to not drop the wind fairing onto the wind shield, and down the front of the van

Note: The slots in the side plate allow for forward / backward adjustment of the wind fairing, as well as gives the ability to adjust the angle of the wind fairing

1. Lower the wind fairing assembly down so it is on the outside of the side plates, if you previously installed the 5/16-18 x 1-1/8" long BHCS in the front spacer during the side rail assembly, it will need to be removed to get the wind fairing in place
2. Insert the 5/16-18 x 1-1/8" long BHCS through the 5/16" washer, apply Blue Loctite 242 to the side of the bolt, insert through the side plate, through the spacer, and into the t-nut. Do not fully tighten.
3. Insert the 5/16-18 x 1" long BHCS through the 5/16" washer, apply anti-seize to the side of the bolt, insert through the side plate, through the 2nd 5/16" washer, and into the nylock nut. Use a 3/16" allen wrench and a 1/2" socket wrench to tighten, do not fully tighten.
4. Use the slots in the side rail assembly to position the wind fairing as desired. Tighten all hardware. The 5/16"-18 hardware used to join the wind fairing and side plates to be tightened to 132 in-lbs (15 N-m).

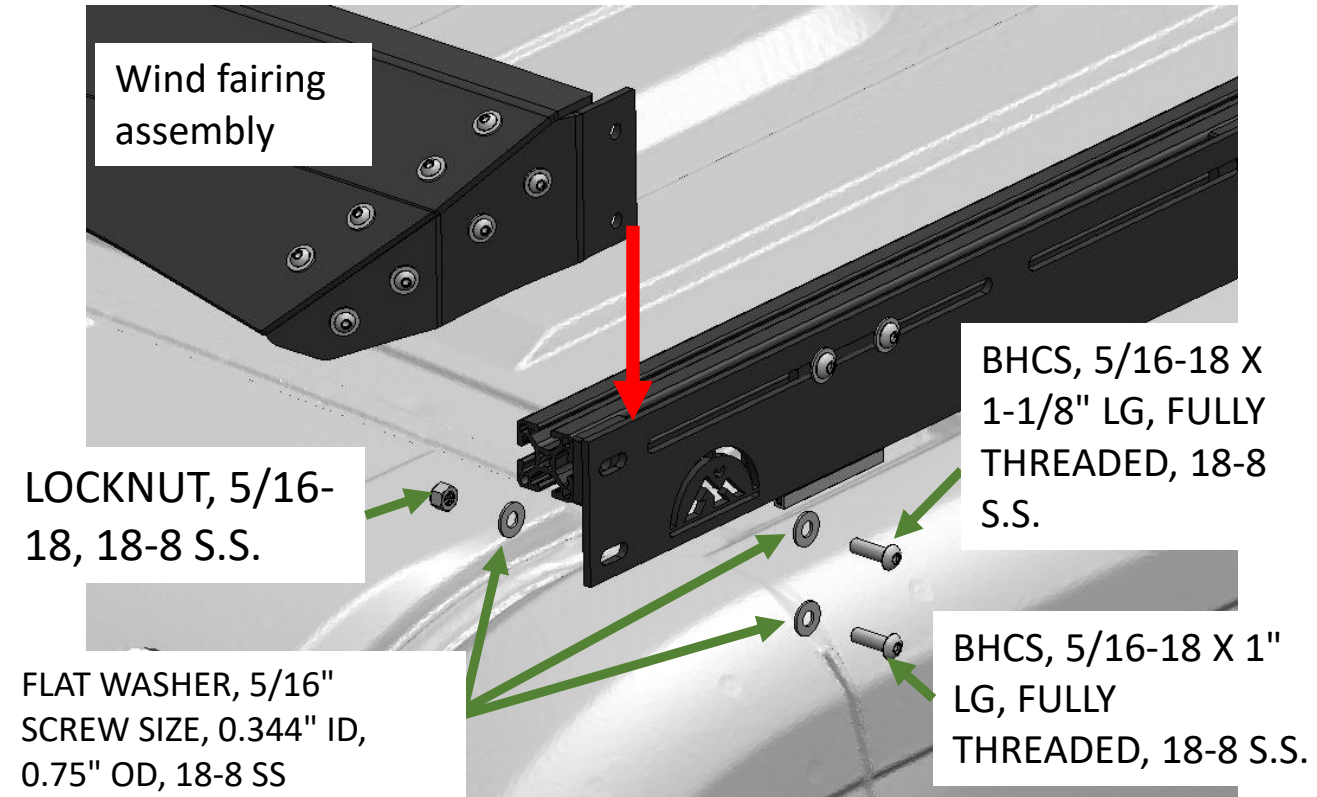

Set side rail to side rail spacing

This step should be completed with 2 people using 2 ladders

1. Position 3 to 4 of the installed cross bars along the length of the rack
 - a) At a minimum place one towards the front, one towards the middle, and one towards the back
 - b) Do not place cross bars directly over a rack bracket
2. Loosely bolt the cross bars to the 8020 rails
3. Once the cross bars are in place, center the rack on the van and set the side rail to side rail spacing so that the cross bars are tight, but can still be removed, or adjusted forward or backwards. As you adjust, the rail to rail spacing, snug up the roof rack brackets and cross bar hardware
 - a) If the rack brackets are too tight, loosen them just enough to allow the rail to rail spacing to be set
4. Once everything is parallel and even with each other, tighten the rack brackets to the van roof. Tighten both bracket bolts evenly by alternating from bolt to bolt. Torque to 90 in-lbs.
5. Double check that all rack brackets are tight before moving to the next step. Once solar panels and other items are installed, tightening and checking this hardware is difficult.

*Image shows a ProMaster 159" WB with obsolete cross-bar L-brackets

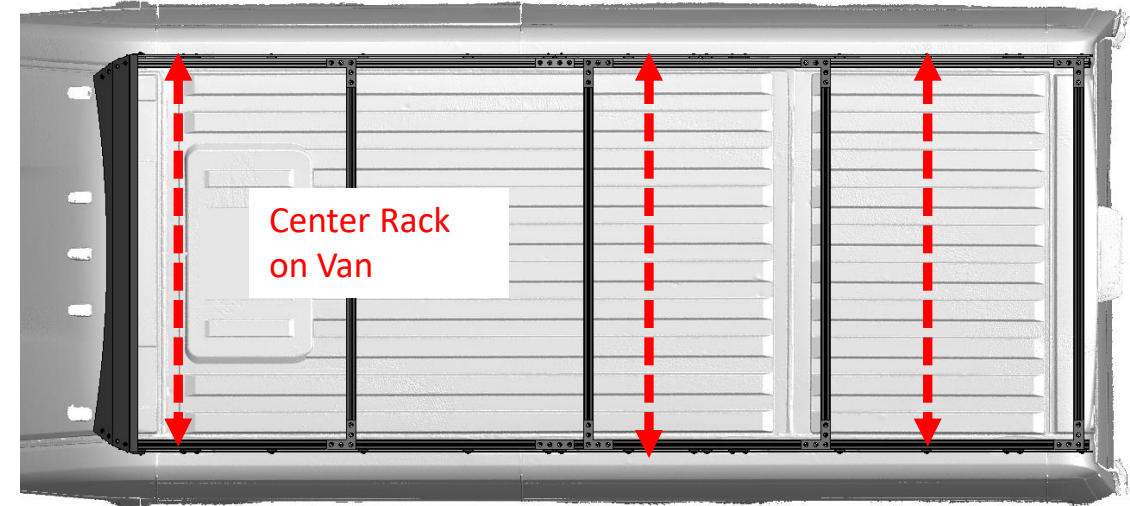

Temporary cross bars near front, middle, and rear

Tighten 5/16-18 hex bolts using ½" wrench

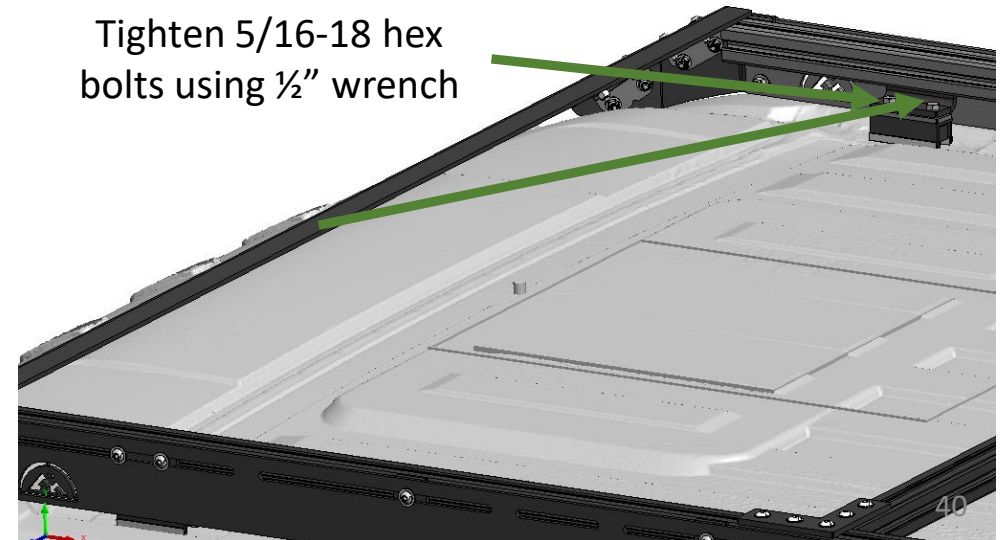

Final Install of Cross Bar Assemblies

1. Remove and reposition any cross bars that were not located in their final locations during the rail to rail spacing step
2. The final position of the cross-bar assemblies can now be set
 - See later page about potential cross bar and splice plate interferences
 - Splice plate hardware, 5/16"-18, to be tightened 132 in-lbs (15 N-m).
 - Cross bar hardware, 5/16"-18, to be tightened 132 in-lbs (15 N-m).
 - Solar panel hardware, 5/16"-18, to be tightened 132 in-lbs (15 N-m).
3. If you completely loosen, or find your self loosening a bolt that already has Loctite on it several times, remove it and apply some more before applying the final torque

Final Torque Checks

Once everything is installed, go back and check that all hardware is tight.

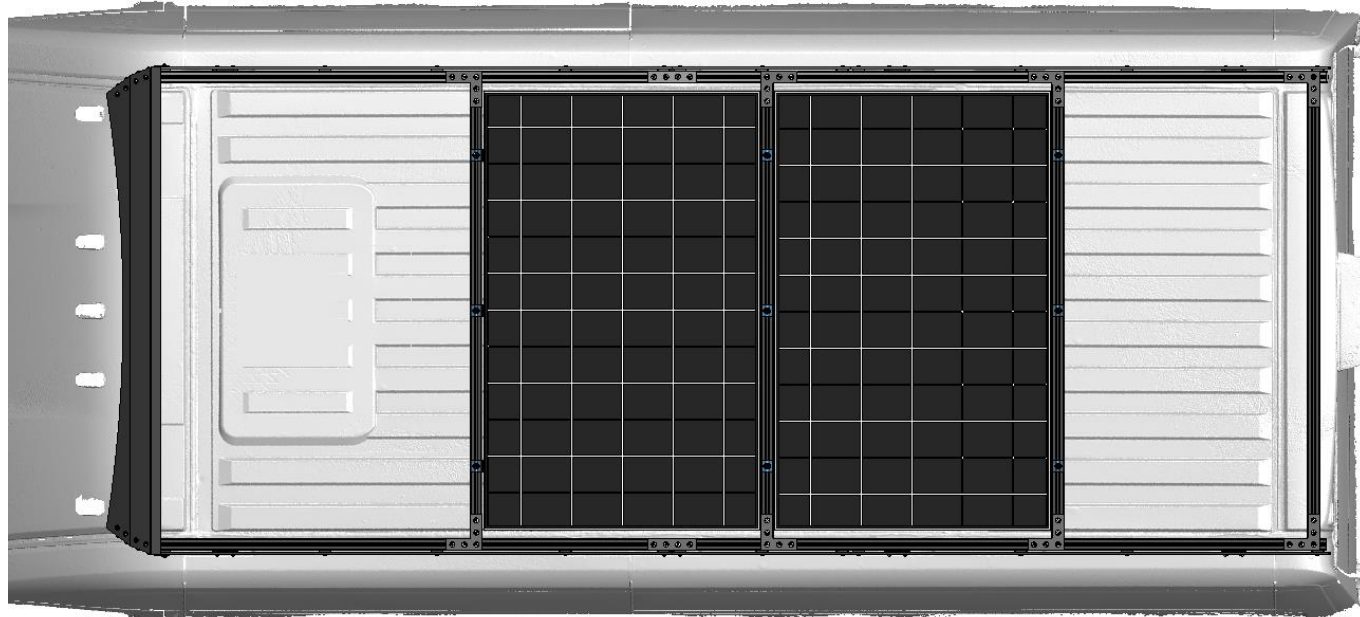
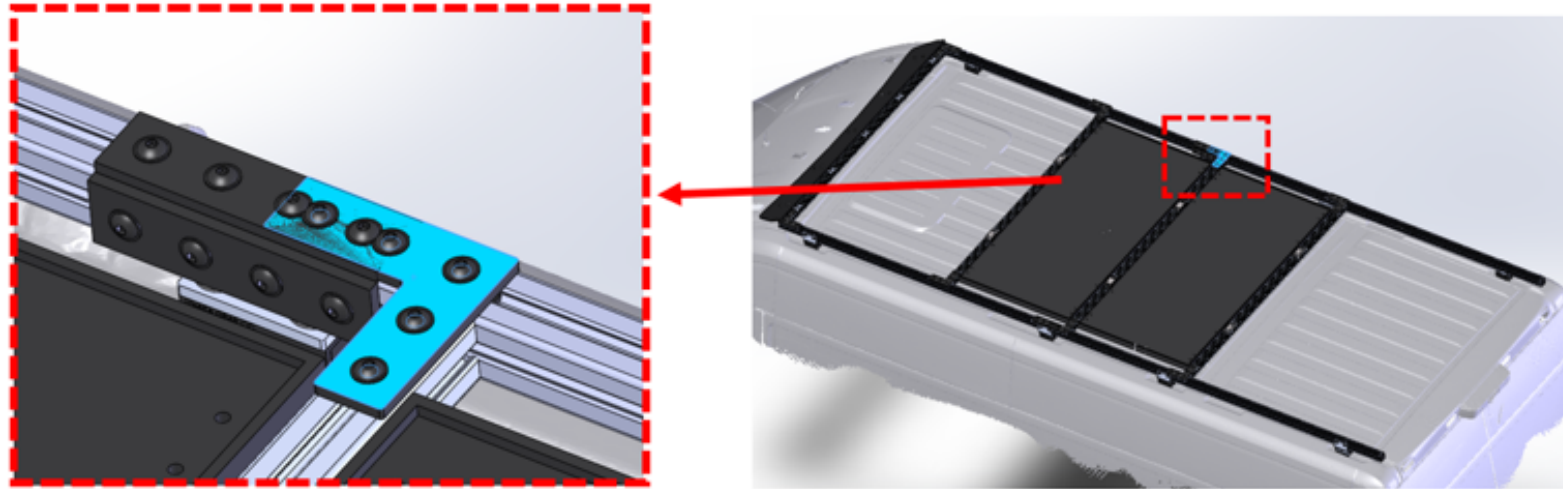

*Image shows a ProMaster 159" WB with obsolete cross-bar L-brackets

Potential Cross Bar to Splice Plate Interference

In some cases, your rack layout may require your cross bars to occupy the same space as the splice plates, see Figure 8. In this example, there are no fans or other items on the roof that would prevent the solar panels and cross bars from being installed a few inches further back to eliminate the interference. If this was not an option, the L-bracket can simply be rotated 180 degrees so that it is pointed away from the splice plates instead of towards them.

Note: The cross-bar bracket shown is an older L-style Bracket. Adjust as needed for the old style, or the new narrow style cross bar connectors.



*Image shows a ProMaster 159" WB

Figure 8: Top splice plate and cross bar bracket interference, flip L-bracket 180 degrees or move splice plate

If you cannot re-arrange your layout the following options can be used to eliminate the interference

- If possible, rotate the L-brackets 180 degrees so they do not interfere with the splice plates.
- If the rack is only supporting solar panels and the front and rear side rail are being joined at an Unaka 8020 adapter bracket on one side, then consider just using 1 splice plate instead of both plates.

Preventative Maintenance Checks

Even though we do not expect any of the hardware to come loose, we recommend checking your roof rack hardware from time to time to help minimize the chance of something coming loose over time. Using the appropriate wrenches check the roof rack hardware to ensure nothing is coming loose at the intervals below.

- Initial check after 4 to 7 days of moderate driving
- Follow Up Check 1 month after moderate driving
- Routine checks 3 to 4 months of moderate driving
- Anytime after moderate driving on bumpy roads or gravel roads

This completes the installation of your HSLD kit.

Legal Disclaimer:

Unaka Gear Co. makes no warranties whatsoever, expressed, or implied, oral, or written to any purchasers, except the limited warranty described on our website. Unaka Gear Co. is hereby specifically excluded from any implied warranty of incidental, secondary, or consequential damages of any kind whatsoever. All purchasers and users of products manufactured by Unaka Gear Co. agree to hold harmless and indemnify Unaka Gear Co from any and all claims arising from their use. Failure to receive notice of any limitations or the limitations contained in this disclaimer shall not serve to extend liability to Unaka Gear Co. for any claims arising out of use of its products.

