



AMERICAN SPECIALTIES, INC.
 441 Saw Mill River Road, Yonkers, NY 10701
 (914) 476.9000 • (914) 476.0688
 www.americanspecialties.com

MODEL №: 0390

ISSUED: 01/14

REVISED: 28 July 2014

EZFill™ DECK MOUNTED TOP-FILL PORT WITH MULTIFEED TANK (Page 1 of 2)

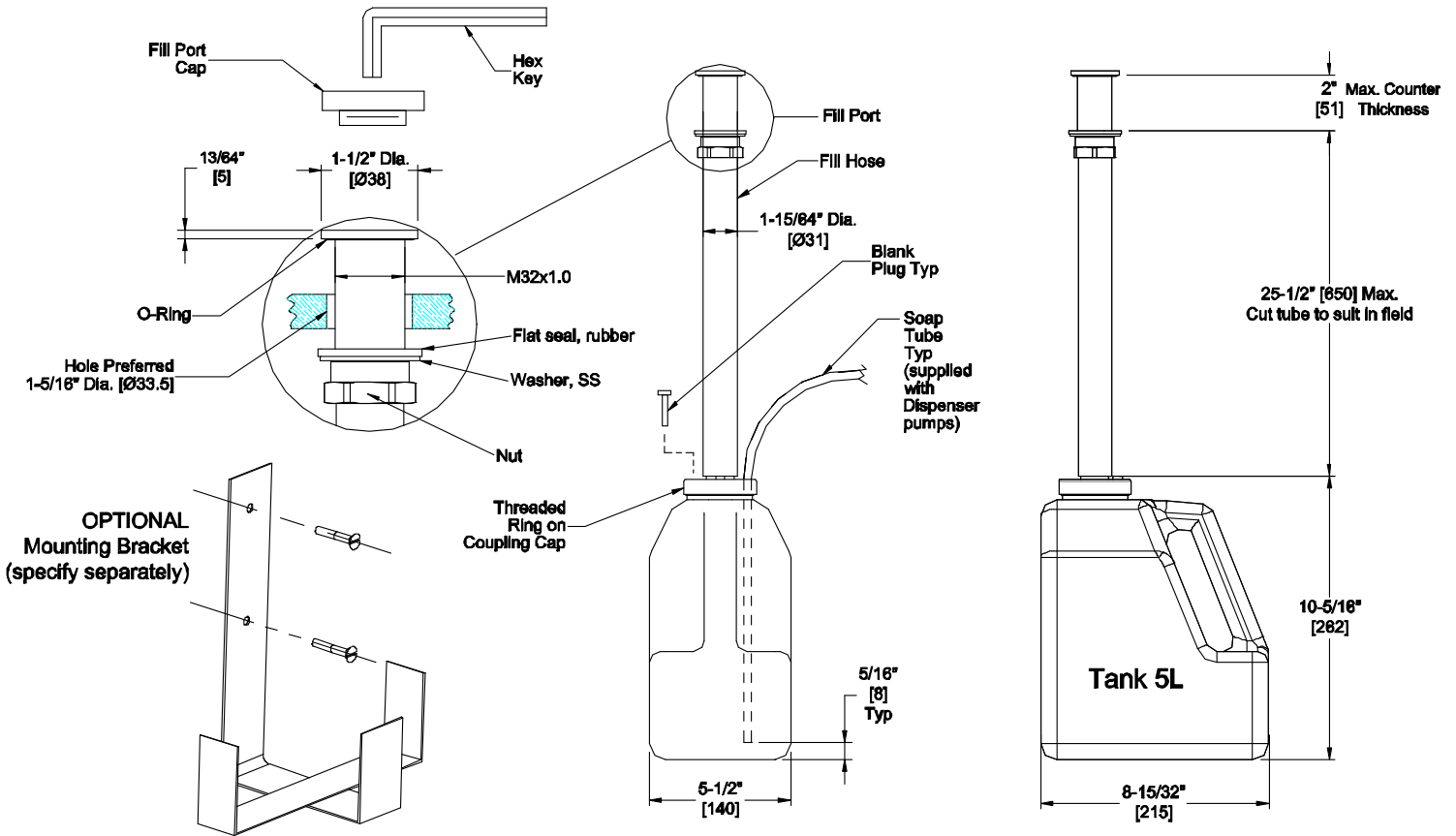

SPECIFICATION

EZFill™ Vanity Mounted Top-Fill Port with Multi-Feed Tank for EZFill™ Vanity Mounted Automatic Soap Dispensing System shall hold 169 oz (5 L) of liquid soap of correct viscosity and without abrasive or particulate content to supply up to six (6) individual EZFill™ vanity mounted automatic soap dispenser units. Multi-Feed tank shall be leak-proof seamless molded translucent plastic to show quantity of soap remaining at any time and will be located under counter, either on floor of base cabinet or in optional wall mounting bracket. Tank shall be connected to under-counter soap distribution tubing (provided with separately specified soap dispensers) and EZFill™ Top-Fill Port flexible fiber-reinforced soap fill hose (provided) with single coupling. Unused soap distribution ports shall be closed with blanking fittings (provided). EZFill™ Top-Fill Port and cover shall have highly polished chrome plated finish over all exposed surfaces. Flange shall have an O-ring to seal against vanity top surface to prevent liquid leaks through counter top. Tank shall be filled by opening fill port cover with service wrench (provided) and loading bulk soap. Concealed air vent hole shall allow pumps (supplied separately) to provide smooth soap delivery performance. EZFill™ Top-Fill Port shall mount on vanity through 1-9/32" (Ø32.5) diameter hole minimum to 1-11/32" (Ø34) max and shall accommodate vanity thickness up to 2" (51). Owner's Manual and Installation Guide (OM & IG) shall be provided with unit in carton.

EZFill™ Vanity Mounted Top-Fill Port with Multi-Feed Soap Tank shall be Model № 0390 of American Specialties, Inc., 441 Saw Mill River Road, Yonkers, NY 10701-4913



AMERICAN SPECIALTIES, INC.
441 Saw Mill River Road, Yonkers, NY 10701
(914) 476.9000 • (914) 476.0688
www.americanspecialties.com

MODEL №: 0390

ISSUED: 01/14

REVISED: 28 July 2014

EZFILL™ DECK MOUNTED TOP-FILL PORT WITH MULTIFEED TANK (Page 2 of 2)

INSTALLATION

Mount EZFill™ Top Fill Port to vanity with rubber washer, SS washer and basin nut (supplied) through 1-5/16" diameter (Ø33.5) mounting hole in deck (provided by others) within 104" (264 cm) of furthest dispenser head so that dispenser supply tubing (provided with soap pumps) will reach to bottom of tank. Place tank on vanity cabinet floor or mount tank with optional bracket in convenient location under vanity with two (2) screws and wall anchors (supplied with bracket). Reconnect soap supply flex tubing (provided attached to EZFill™ Top-Fill Port and tank transfer fitting) to bottom of port fitting and screw transfer fitting onto Multi-feed tank. Connect all dispenser heads soap pump supply tubes to individual transfer ports so that each tube end is just above bottom of tank or install blank plugs to seal unused ports. Fill tank from EZFill™ Top-Fill Port with appropriate viscosity non-abrasive soap to correct level and test system for operation.

OPERATION

System shall allow filling soap reservoir from top of vanity without requiring removal of tank under vanity. Up to six (6) individual dispensers will draw soap as required to operate until supply is depleted. Unused transfer ports are blocked with solid plugs (provided) to prevent overflow, contamination and evaporation. Soap is manually replenished on service interval determined by maintenance schedule. See OM & IG for complete description of Features and Operations.