



AMERICAN SPECIALTIES, INC.
 441 Saw Mill River Road, Yonkers, NY 10701
 (914) 476.9000 • (914) 476.0688
 www.americanspecialties.com

MODEL №: 0197

ISSUED: 2-08

REVISED: 6 NOV 2018

SURFACE MOUNTED HIGH-SPEED HAND DRYER (PAGE 1 OF 2)

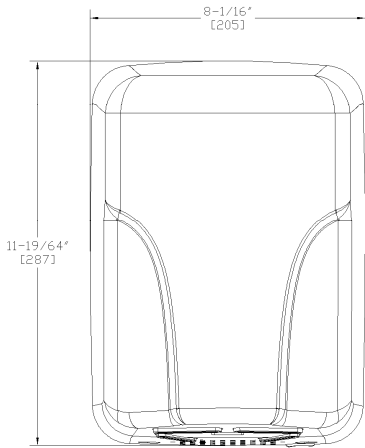

FRONT VIEW

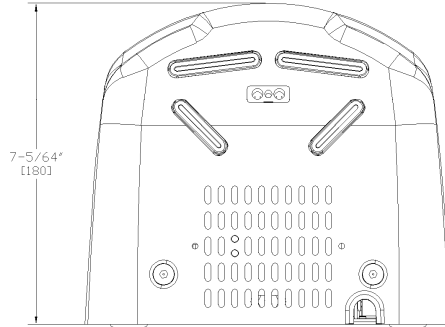

BOTTOM VIEW

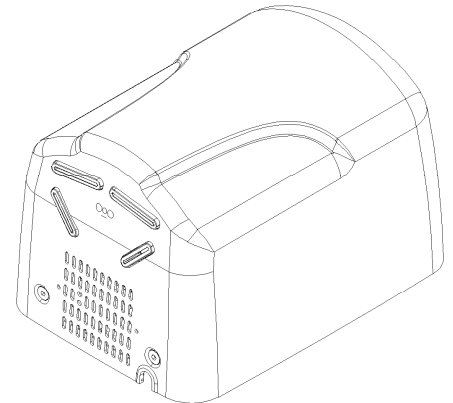

ISOMETRIC

NOTE

ALL DIM'S INCH (MM)

ILLUSTRATION FOR REF ONLY AND NTS

FOR CLEANING INSTRUCTIONS SEE APPROPRIATE SECTIONS IN PRODUCT CARE & MAINTENANCE BULLETIN (PCM) ON ASI WEBSITE

SPECIFICATION

Surface Mounted High-Speed Hand Dryer shall operate automatically from IR sensor activated by beam reflection from objects placed in sensing zone. Motor and heating element shall have internal resetting automatic thermal protection. Unit shall develop 63.6 CFM (108 m³/h) of heated air and shall provide drying time of less than 15 seconds. Warm air output temperature and velocity shall be adjustable by owner. Cover shall be fabricated of heavy-duty, one piece formed stainless steel 1/16" [1.5] thick finished on all exposed surfaces as satin or bright polished (by option specified) or heavy-duty, one piece formed steel 1/16" [1.5] thick finished on all exposed surfaces with white porcelain enamel. Fixed directional air nozzle shall be heavy-duty, rust proof and highly tamper resistant. Air intake slots shall not allow access to internal parts. Circuitry shall have self-adjusting time-out and fail-safe off protection controlled by a microprocessor that shall detect and reject false signals and shall automatically self-calibrate to provide uniform sensitivity over its entire life span. Sensitivity shall be adjustable by owner to suit mounting conditions and intended usage population. Entire unit shall be internally electrically grounded. Motor speed shall be adjustable by owner in range between maximum power and maximum efficiency. Dryer unit shall have C-UL-US[®], CE, and TÜV approval and be listed under the re-examination services of Underwriters Laboratories, Inc. Unit shall be warranted against defects in materials or workmanship for five (5) years.

Surface Mounted High Speed Hand Dryer shall be Model № 0197-__ {specify voltage suffix}-__ {specify color option if other than white} of American Specialties, Inc., 441 Saw Mill River Road, Yonkers, NY 10701-4913

INSTALLATION

Surface mount unit on wall with four (4) 1/4" [6.4] washers and screws or bolts (not supplied) through holes (provided) in a corrosion protected steel back plate into suitable prepared mountings (by others) or other suitable mounting hardware (by others) to suit wall conditions. Electrical service is supplied and connected (by others) prior to installing cover. Cover is secured to back plate with recessed, pin-hex socket head cap screws (supplied). For compliance with ICC/ANSI 117-1 2009 and 2010 ADA Accessibility Standards for adults, install unit with bottom of sensor lens 48" [1219] maximum above finished floor (MAX AFF) if unobstructed reach access is provided or 44" [1118] MAX AFF if forward reach over an obstruction (e.g. vanity or commode) with reach depth greater than 20" [508] and less than 25" [635] is only provided. For general utility, install unit so that sensor lens is 44" to 54" [1118 to 1372] AFF.

OPERATION

Activate dryer by placing hands under sensor. Dryer automatically shuts off after user removes hands from sensor zone.



AMERICAN SPECIALTIES, INC.
 441 Saw Mill River Road, Yonkers, NY 10701
 (914) 476.9000 • (914) 476.0688
 www.americanspecialties.com

MODEL №:	0197
ISSUED:	2-08
REVISED:	6 NOV 2018

SURFACE MOUNTED HIGH-SPEED HAND DRYER (PAGE 2 OF 2)

COLOR OPTIONS*

Unit is supplied with white finish unless color option is specified. Specify optional covers Bright or Satin Stainless Steel by adding appropriate code number suffix to standard model number.

COLOR CODE	COVER COLOR
-92	Bright Stainless Steel
-93	Satin Stainless Steel

RATINGS

MODEL	TYPE	AIR VELOCITY	TIMING SAFETY	VOLTS AC FREQUENCY Hz	AMPS	WATTS x1000	COLOR
0197-1	Hand	145.4 - 213 mph 65 - 95 m/s	Automatic 60 second Shut-Off	110-120 V 50/60 Hz	14.58 Max	1.75	White*
0197-2				208-240 V 50/60 Hz	7.30 Max		

MOTOR	H/P	RPM x1000	FAN TYPE	HEATING ELEMENT	CFM m ³ /h	AIR OUTPUT TEMPERATURE
Brush Type Dual Ball Bearings	1	7-18	Multi-Inlet Centrifugal	350-700 Watt Nichrome wire with auto reset circuit breaker	63.6 108	140° F ± 5 @ 77° F (60° C ± 2.4 @ 25° C) Ambient room temp

NET WT	SHIP WT	DRYING TIME	SENSING RANGE	SAFETY	WATER PROTECTION
12.8 Lbs 5.8 kg	13.7 Lbs 6.2 kg	Less Than 15 seconds	5-1/8" to 13-25/32" [130-350] ADJUSTABLE Standard = 7" ± 25/32" [178 ± 20]	C-UL-US®, CE, TÜV-GS	Drip Proof IP23

SENSOR TYPE	DRYING PERSISTENCE	MOTOR THERMAL PROTECTION	HEATER THERMAL PROTECTION	SOUND PRESSURE
IR 780 nm	Automatic ≤ 2 second Hold- On Shut-Off delay	Shut off 120 VAC @ > 275 °F {> 135 °C} 240 VAC @ > 203 °F {> 95 °C}	Shut off @ > 185 °F {> 85 °C} Reset on @ < 167 °F {< 75 °C}	61.2 dB-A @ 2m 65.2 dB-A MAX @ 2m