

AC-630 Diaphragm Meter

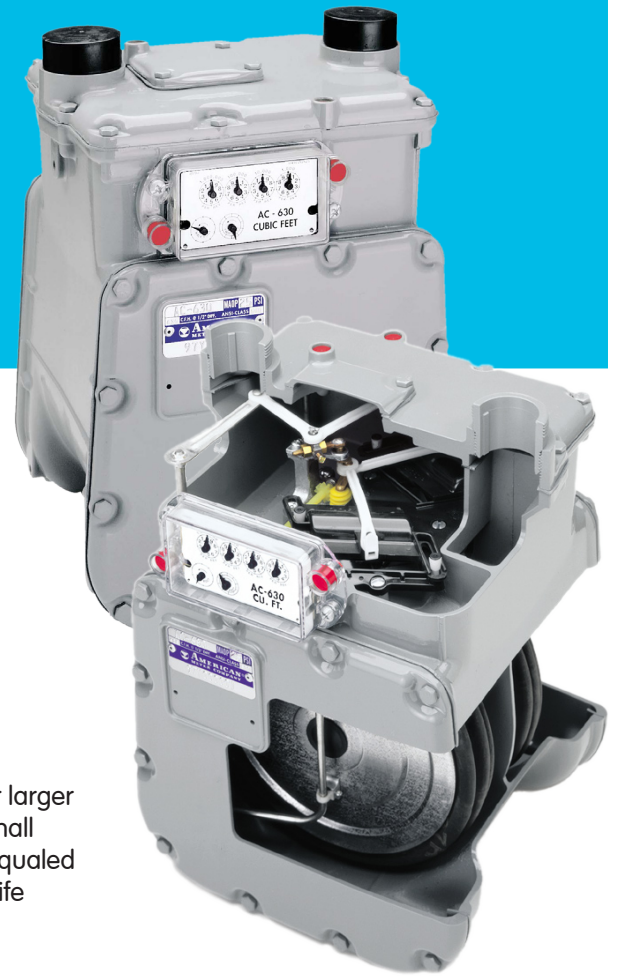

Designed to meter a variety of gases for large residential/commercial/small industrial applications at pressures up to 25 PSIG and flow rates to 630 SCFH at 1/2" W.C. differential pressure

Features

- Die-cast aluminum case
- Oil-impregnated, self-lubricating bushings
- Molded, convoluted diaphragms for smooth operation and long life
- Rigid, reinforced flag rods for positive alignment and sustained accuracy
- Graphite-filled phenolic valves to minimize wear
- Long-life, low friction, grommet seals
- Single coat polyester primer with high solids polyurethane top coat
- Security seals that indicate tampering

Advantages

- Temperature compensation available from -30°F to 140°F (-34°C to 60°C)
- 630 SCFH (17.8 m³/h) (0.60 specific gravity gas) at 1/2-inch W.C. differential
- AMI/AMR compatibility
- Meets ANSI B109.2 specifications

Applications

The AC-630 is ideally suited for larger residential, commercial and small industrial installations. It is unequalled for accuracy retention and for life cycle maintenance economies.

Options

- Regular or Temperature Compensated
- Pointer or odometer index
- 2ft³ or 0.05m³ drive
- 20 LT, 30 LT, 45 LT and other connection sizes
- 25 PSIG (1724 mBar) Maximum Allowable Operating Pressure (MAOP)
- Pressure compensating indexes
- Standard or UV protected index covers
- Meter bars
- Connection sets
- Remote Volume Pulsers
- 7" or 8.25" center-to-center connections

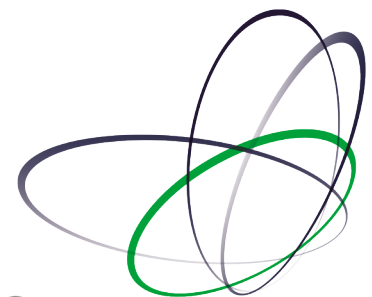

i-meter[®]
Innovative Metering Solutions

AC-630 Diaphragm Meter

Weight = 21 lbs

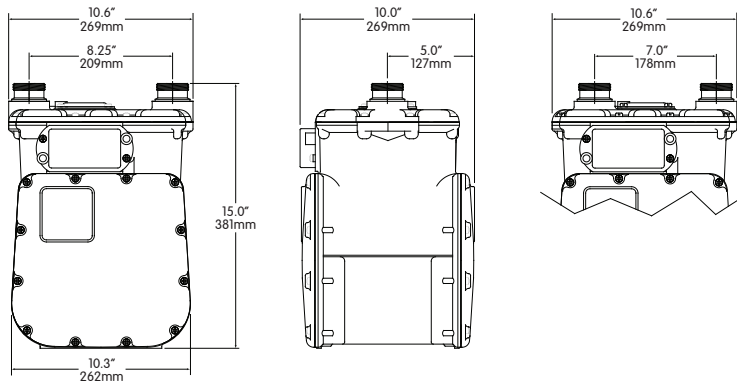

Capacities (0.60 specific gravity gas)

Line Pressure PSIG (mbar)	Differential Inches W.C. (mbar)	SCFH (m ³ /h)
0.25 (17)	1/2 (1.2)	630 ^{1,2} (17.8)
0.25 (17)	2 (5)	1320 (37.4)
1 (69)	2 (5)	1340 (37.9)
2 (138)	2 (5)	1390 (39.4)
5 (345)	2 (5)	1515 (42.9)
10 (690)	2 (5)	1710 (48.4)
15 (1035)	2 (5)	1890 (53.5)
20 (1380)	2 (5)	2010 (56.9)
25 (1724)	2 (5)	2160 (61.2)

1 - Propane - 397 cfh (11.2 m³/h)

2 - Butane - 347 cfh (9.8 m³/h)

AC-630 Proof Curve

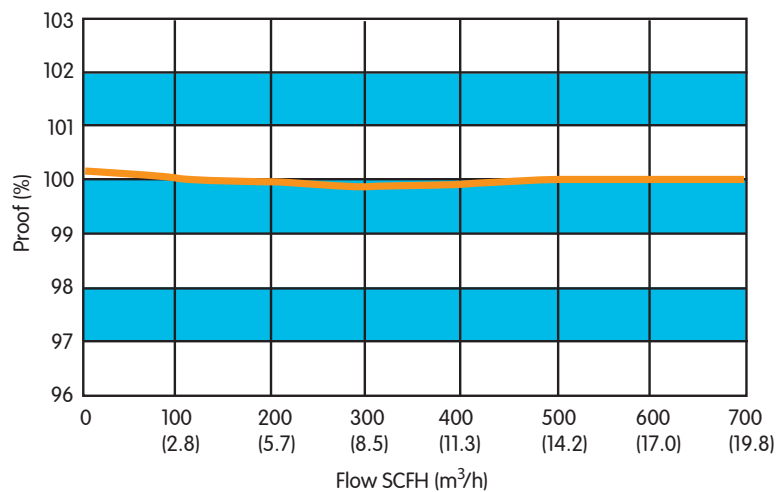

ISO 9001:2000



Certification No. 006697