

AC-250 Diaphragm Meter

The standard for measuring a variety of hydrocarbon gases at pressures up to 10 PSIG and flow rates up to 250 cubic feet per hour

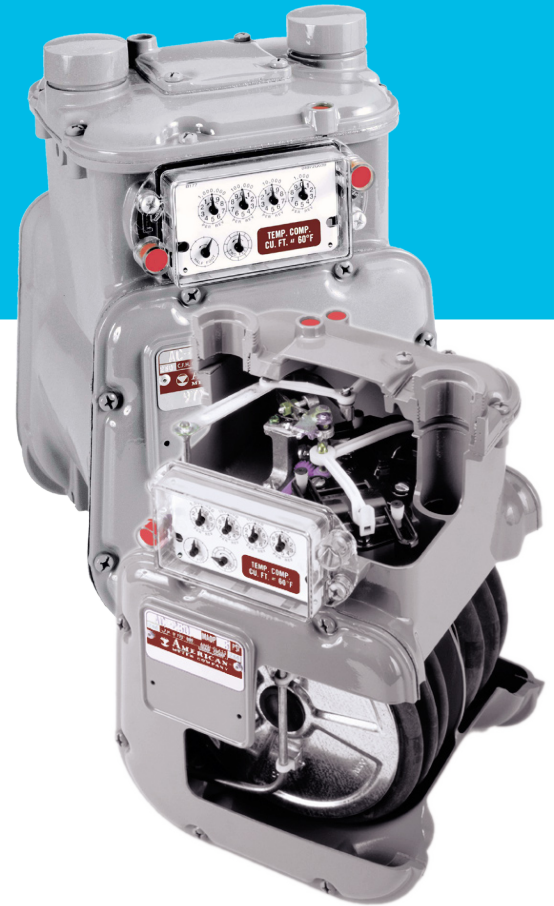

Features

- Die-cast aluminum case
- Oil-impregnated, self-lubricating bushings
- Molded, convoluted diaphragms for smooth operation and long life
- Rigid, reinforced flag rods for positive alignment and sustained accuracy
- Graphite-filled phenolic valves to minimize wear
- Long-life, low friction, grommet seals
- Single coat polyester primer with high solids polyurethane top coat
- Security seals that indicate tampering

Advantages

- Temperature compensation available from -30°F to 140°F (-34°C to 60°C)
- 250 SCFH (7.1 m³/h) (0.60 specific gravity gas) at 1/2-inch W.C. differential
- AMR/AMI compatibility
- Meets ANSI B109.1 specifications

Applications

The Elster American Meter class AC-250 is the industry's most cost-effective gas meter for residential and small commercial applications. It is unequalled for accuracy retention and for life cycle maintenance economies.

Options

- Regular or Temperature Compensated
- Pointer or odometer index
- 1ft³, 2ft³, or 0.05m³ drive
- 10 LT, 20 LT, 30 LT, and other connection sizes
- 5 or 10 PSIG (345 or 690 mbar) Maximum Allowable Operating Pressure (MAOP)
- Pressure compensating indexes
- Standard or UV protected index covers
- Meter bars
- Connection sets
- Remote Volume Pulsers



AC-250 Diaphragm Meter

Weight = 12 lbs

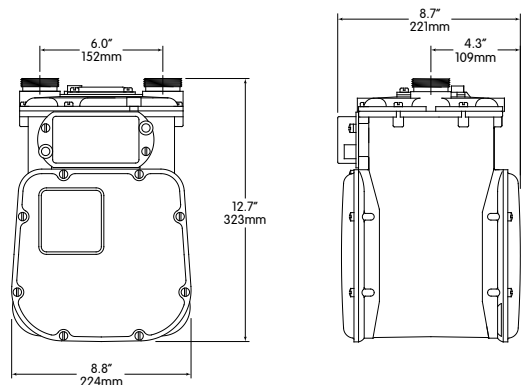

Capacities (0.60 specific gravity gas)

Line Pressure PSIG (mbar)	Differential Inches W.C. (mbar)	SCFH (m ³ /h)
0.25 (17)	1/2 (1.2)	250 ^{1,2} (7.1)
1 (69)	2 (5)	583 (16.5)
2 (138)	2 (5)	600 (17.0)
5 (345)	2 (5)	656 (18.8)
10 (690)	2 (5)	742 (21.0)

1 - Propane - 158 SCFH (4.5 m³/h)

2 - Butane - 138 SCFH (3.9 m³/h)

AC-250 Proof Curve

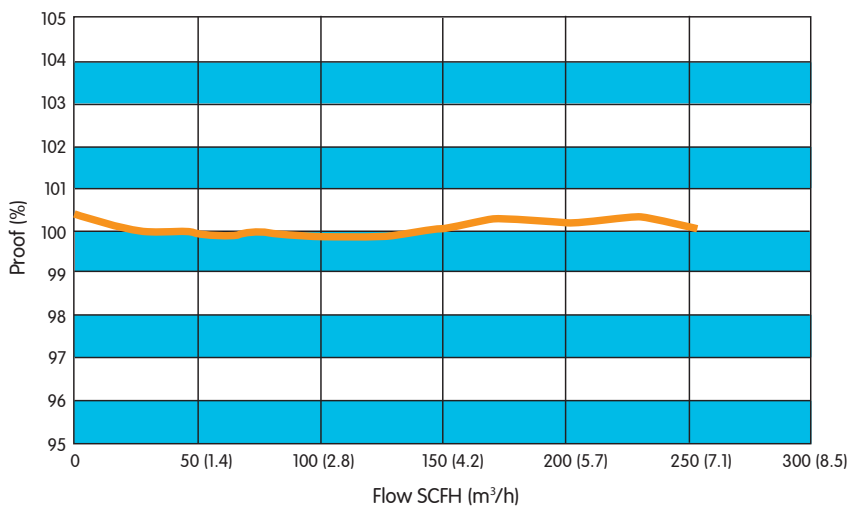

ISO 9001:2000



Certification No. 006697