

REV	DESCRIPTION	DATE	APPROVE
P1	PRELIMINARY	10/06/12	WL
P2	PRELIMINARY	13/03/20	YJW
P3	PRELIMINARY	13/05/20	YJW

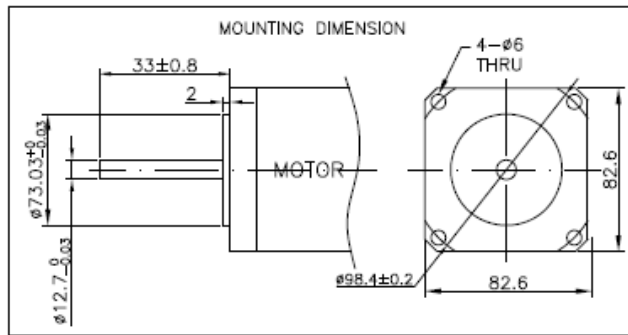
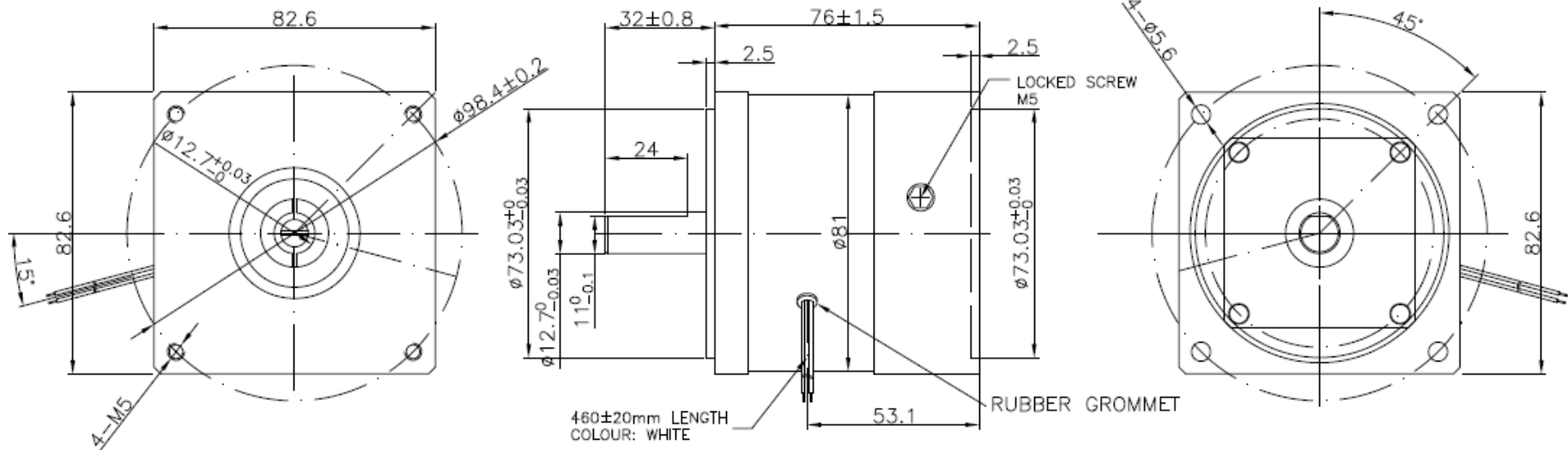

- NOTE:
- VOLTAGE: 24VDC
 - STATIC TORQUE: 1.68Nm Min.
 - RATED CURRENT: 0.369A
 - POWER: 7.3W
 - RESISTANCE: 65.1 Ohms
 - START VOLTAGE: 15VDCMAX
 - HI-POT: 500VAC/1S, 2mA
 - POWER OFF BRAKE

NOTE: THIS DRAWING HAS BEEN CREATED BY AUTOCAD. MANUAL REVISIONS ARE NOT ALLOWED.

MATERIAL		TOLERANCE UNLESS OTHERWISE SPECIFIED ISO 2768-1 MEDIUM			
DRAWN ZQY	CHECKED	APPROVED - DATE	FILENAME	DATE xx/xx/xx	SCALE N/A
DRIVE SYSTEMS GROUP			Nema 34 Power Off Brake		SHEET 1/1
			DY-PSF256-46-225-S5		