

Generator set
Sound-proof type
DT150C5S-AU

SPECIFICATIONS

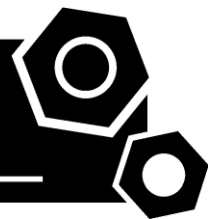

DTC-AU series DT150C5S-AU

50 Hz @ 1500rpm,3-phase/5-wiring

1 Standards & Conditions

Design Standards

The designs and the productions are in conformity with:

- Conformance Européenne (CE)
- ISO8528-5:2005
- AS 3000-2018
- AS 3010-2017

Environmental Operating Conditions

- Installation place: Outdoors or indoors (well ventilated).
- Ambient temperature: -25°C to 50°C. The coolant heater is needed when the temperature is below 5°C
- Humidity: Less than 90%.
- Altitude: Below one thousand (1000) meters above sea level.

Factory Inspection

- Inspection items.
- Protection devices working test.
- Starting ability in normal temperature.
- 50% rated power load moment capability.
- Voltage deviation and speed variation: 0%, 25%, 50%, 75%, 100%, 110% Load.

Painting Process

- Painting process specifications and colors are based on the manufacturer's standard.
- The customer could also choose the color which the manufacturer offers.

2 General Features

- Cummins engine 6BTAA5.9-G12
- Close coupled to Stamford alternator UC1274F
- Microprocessor control module PLC-920
- Schneider main circuit breaker: 250A
- Rotate speed governor: Electrical governor
- Excitation system: Self excited, SHUNT
- A.V.R model: AS480
- Key switch
- Emergency stop switch
- ATS(automatic transfer switch)receptacle

- Remote run connector
- 2x12V/72AH sealed for life maintenance free battery
- Lockable battery isolator switch
- Powder coated canopy
- 50°C radiator
- Steel base frame
- Vibration isolators between the engine/alternator and base frame
- Dry type air filter
- Base fuel tank for 26 hours running
- Drain points for fuel tank
- Operation Manual / Specifications

3 Equipment

General technical data

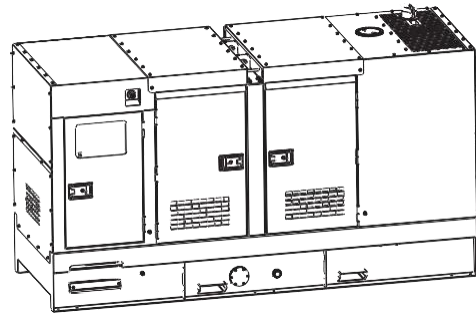

ModelDT150C5S-AU
 Fuel tank850L
 Dry weight..... 2417kg
 Sound pressure level @ 7m..... 65.0dBA
 Dimensions LxWxH. 3150x1160x2091mm
 Standby Power..... 165kVA/132kW
 Prime Power..... 150kVA/120kW

Voltage	380V	400V	415V		
Ampere	227.9A	216.5A	208.7A		
Genset Fuel Consumption					
Frequency/Load	25%	50%	75%	100%	110%
50Hz (L/h)	9	17.5	25.5	34	38

3RZHU 6VWHP

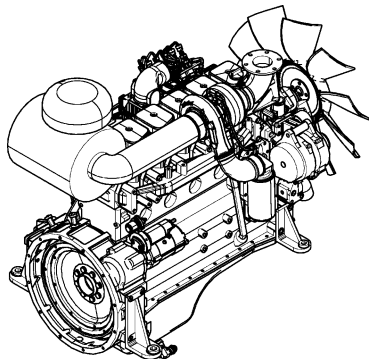

Engine Manufacturer/Brand	Cummins
Engine Model.....	6BTAA5.9-G12
Dimensions LxWxH.....	1215.8*730.5*1153.6
Dry Weigh (approx.)	653kg
Number of Cylinders.....	6
Bore.....	102mm
Stroke.....	120mm
Displacement	5.9L
Compression Ratio	17.3
Type of injection.....	Direct injection
Intake System	Turbocharged, water-to-air charge cooled
Intake Resistance	≤ 6.28kPa
Cooling System.....	Water cooled
Fan	Pusher
Battery Voltage.....	24V
Type of Fuel.....	Diesel
Type of Oil	ACEA E2, API CF, CF-4, CG-4
Oil Capacity	16.4L
Type of Coolant.....	Glycol mixture
Coolant Capacity	10.0L
Back Pressure	≤ 10.1kPa
Standby Power.....	140kW
Prime Power.....	155kW

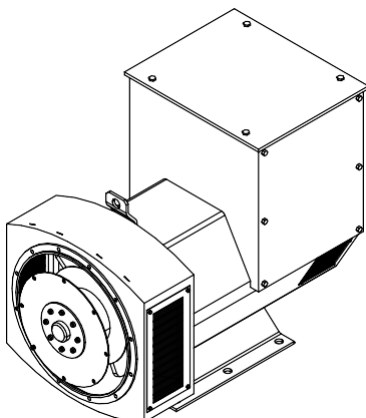

Alternator Manufacturer/Brand.....	Stamford
Alternator Model.....	UCI274F
Exciter	Brushless
Cooling Fan	Cast alloy aluminum
Windings	100% copper
Insulation Class.....	H
Winding Pitch	2/3
Terminals	12
Drip Proof.....	P23
Altitude	≤1000m
Overspeed	2250rpm
Air Flow	N/A
Voltage Regulation	±1.0%
Total Harmonic TGH / THCat no load < 1.5 % - on load < 5%	
Telephone Interference	THF<2%;TIF<50

PLC-920 Control System

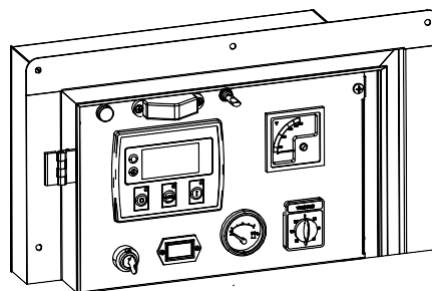

PLC-920 is an advanced control module based on microprocessor designed to control the engine via push buttons on the front panel. The module is used to start and stop the engine and indicate fault conditions, automatically shutting down the engine and giving a true first fault condition of an engine failure.

Standard Control Function

- Manual Engine Control Module
- Low Oil Pressure
- High Engine Temperature
- Auxiliary Shutdown
- Overspeed Protection
- Protection hold-off timer
- Charge Failure warning

4 Overall Dimensions

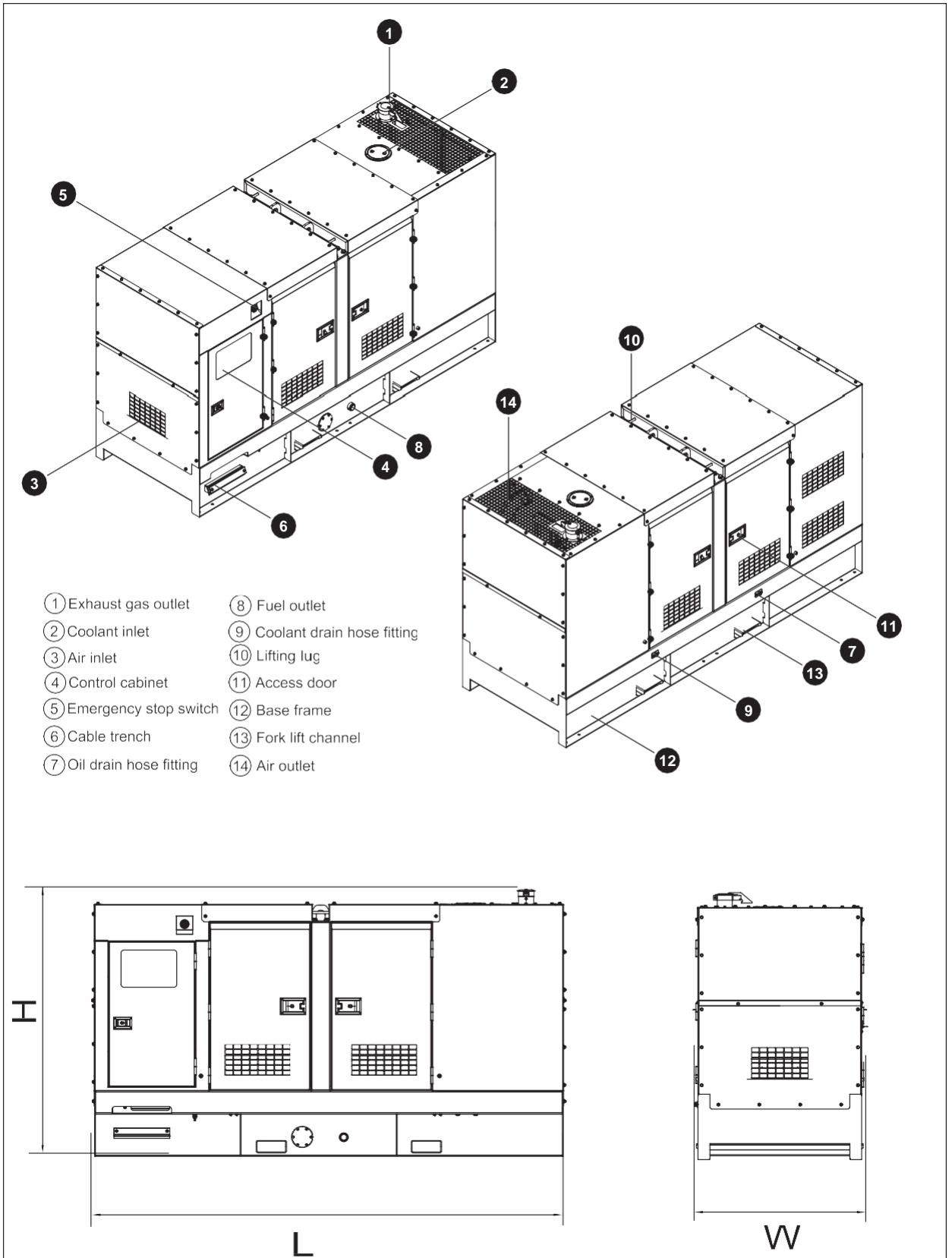

5 Control System

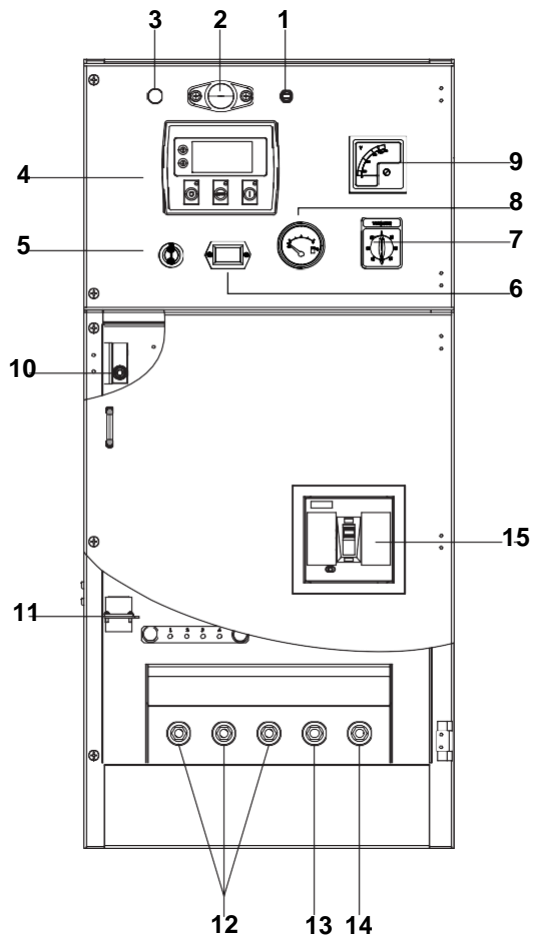

Control & field wiring cabinet

Ref.	Description
1	Control cabinet lamp switch
2	Control cabinet lamp
3	Charge indicator
4	Control module
5	Key switch
6	Time counter
7	Voltage changer-over switch
8	Fuel level meter
9	Voltage meter
10	Limit switch
11	Mains input/Remote control/ATS connector
12	Live wire terminal
13	Neutral wire terminal
14	Ground wire terminal
15	Main circuit breaker

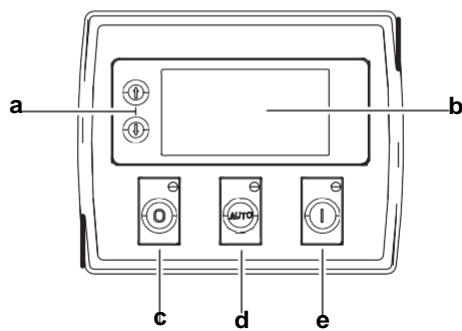

Control module

Ref.	Description
a	Navigation button«» Accept (Configuration mode only)
b	Main status display
c	Stop/reset button«» Next page (Configuration mode only)
d	Auto start button«» Decrease value/next item (Configuration mode only)
e	Start button«» Increase value/next item (Configuration mode only)

1000033797-A2-E

10.2020

<http://www.gogopower.com.au>

*Specification may change without prior notice. For more info.,
[contact Gogopower or your local distributors please.](#)*