

MANUAL DE MONTAGEM

ASSEMBLY INSTRUCTIONS

INSTRUCCIONES DE MONTAJE

NOTICE DE MONTAGE

MONTAGEANLEITUNG

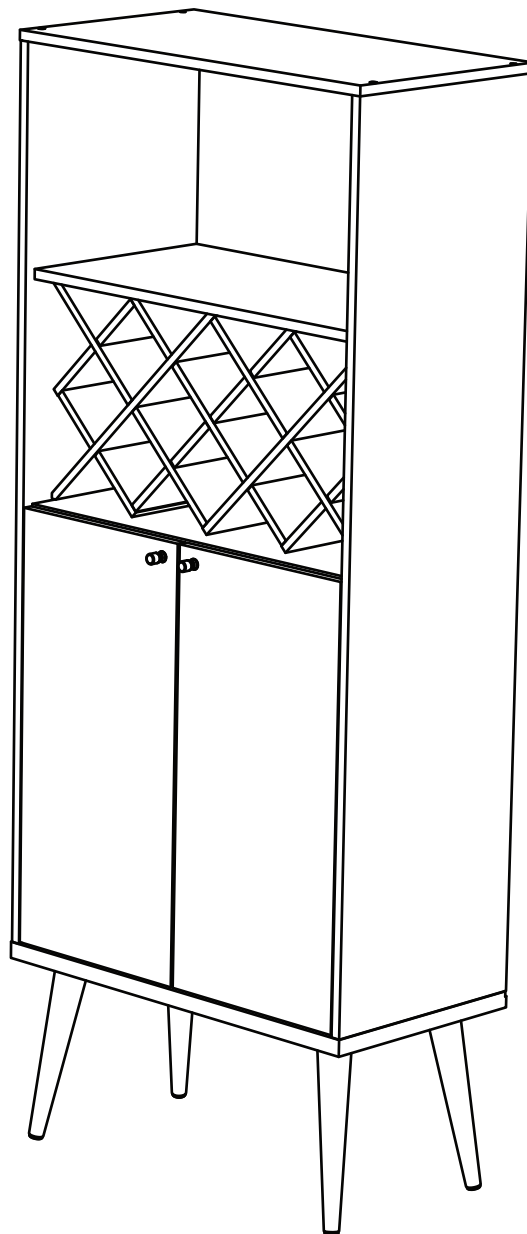

COD BR: 87500

COD. 2088-1x

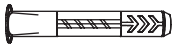

A

COD. 9425-4x

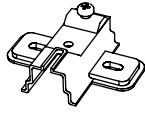

B

COD. 3934-1x

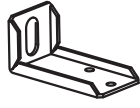

C

COD. 5681-1x

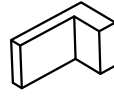

D

COD. 9328-2x



E

COD. 0494-4x



F

COD. 1668-36x



G

COD. 8471-4x

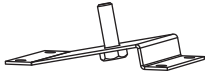

H

COD. 0342-18x

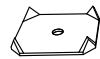

I

COD. 8240-1x



J

COD. 7292-1x



K

COD. 8903-4x

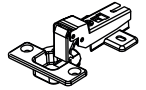

L

COD. 7291-8x



M

COD. 0599-4x



N

COD. 7499-50x

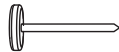

O

COD. 3557-3x



P

COD. 3527-8x



Q

COD. 7519-16x



R

COD. 8056-16x



S

COD. 0357-18X



T

COD. 6244-1x



U

COD. 3187-2x



V

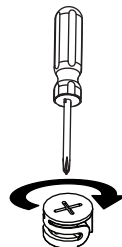

DESCRIÇÃO/DESCRIPTION/DESCRIPCIÓN/DESCRIPTION/BESCHREIBUNG

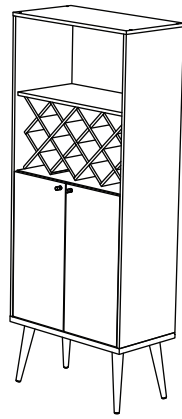

L:673mm A:1670mm P:355mm
 W:26.50in H:65.75in D:13.98in
 L:673mm A:1670mm P:355mm
 L:673mm H:1670mm P:355mm
 B:673mm H:1670mm T:355mm

CÓD:87500

PEÇA PART PIEZA PIECE STÜCK	QUANTIDADE QUANTITY CANTIDAD QUANTITÉ MENGE	DESCRIÇÃO	DESCRIPTION	DESCRIPCIÓN	DESCRIPTION	BESCHREIBUNG	CAIXA BOX CAJA BOÎTE BOX
05	02	PRATELEIRA	SHELF	ESTANTE	ÉTAGÈRE	FACH	01
06	02	FUNDO SUPERIOR	UPPER BACKPLATE	FONDO SUPERIOR	PLATEAU ARRIÈRE SUPÉRIEUR	OBERE RÜCKWAND	01
07	02	FUNDO INFERIOR	BOTTOM BACKPLATE	FONDO INFERIOR	PLATEAU ARRIÈRE INFÉRIEUR	UNTERE RÜCKWAND	01
08	02	PORTA	DOOR	PUERTA	PORTE	TÜR	01
12	02	LATERAL MENOR DIR	SHORT RIGTH SIDE	LATERAL DERECHA MENOR	BAS DE L'ÉTAGÈRE CARRÉ	KLEINERE RECHTE SEITE	02
13	02	LATERAL MENOR ESQ	SHORT LEFT SIDE	LATERAL IZQUIERDA MAYOR	CÔTÉ GAUCHE PLUS PETIT	KLEINE LINKE SEITE	02
14	01	CENTRAL DIREITA	RIGHT CENTRAL PART	PIECA CENTRAL DERECHA	CENTRE DROIT	RECHTE HÄLFTE	02
15	01	CENTRAL ESQUERDA	LEFT CENTRAL PART	PIECA CENTRAL IZQUIERDA	CENTRE GAUCHE	LINKE HÄLFTE	02
16	02	LATERAL ESQUERDA	LEFT SIDE	LATERAL IZQUIERDA	CÔTÉ GAUCHE	LINKE SEITE	02
17	02	LATERAL DIREITA	RIGTH SIDE	LATERAL DERECHA	CÔTÉ DROIT	RECHTE SEITE	02
18	01	PRATELEIRA	SHELF	ESTANTE	ÉTAGÈRE	FACH	01
19	01	BASE	BASE	BASE	BASE	BASIS	01
20	01	TAMPO	TOP BOARD	CUBIERTA	PLATEAU	PLATTE	01
21	01	LATERAL ESQUERDA	LEFT SIDE	LATERAL IZQUIERDA	CÔTÉ GAUCHE	LINKE SEITE	01
22	01	LATERAL DIREITA	RIGTH SIDE	LATERAL DERECHA	CÔTÉ DROIT	RECHTE SEITE	01
50	04	PE	LEG	PATA	PIED	FUß	02

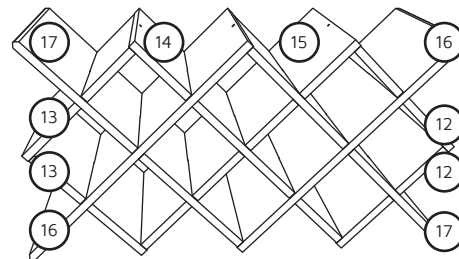
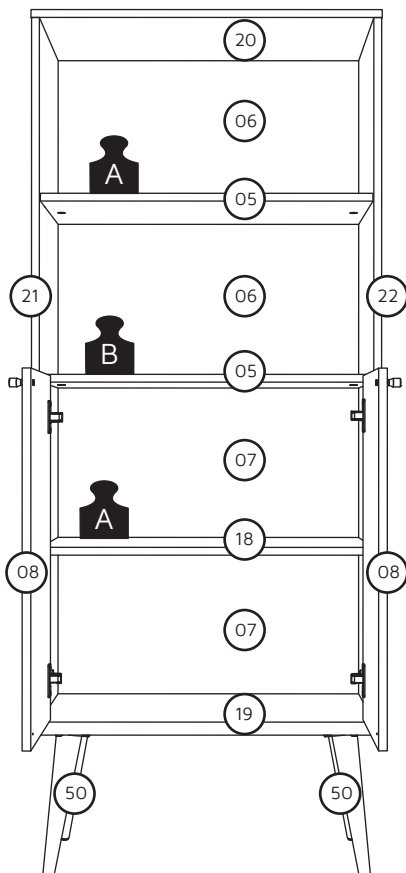

A = 03KG - 6.6LB
B = 12KG - 26.5LB

01

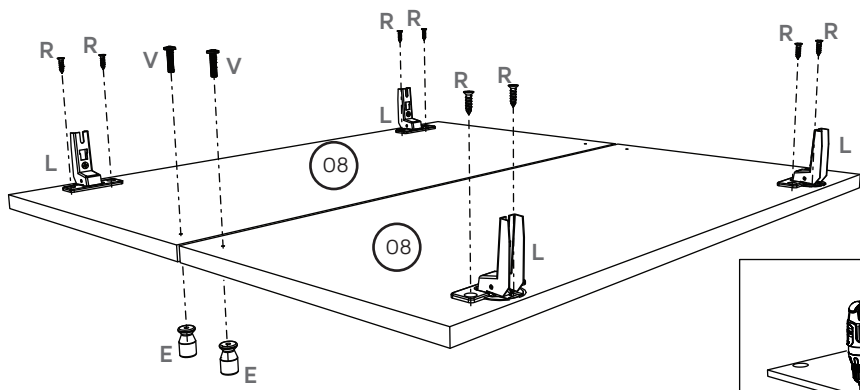

02

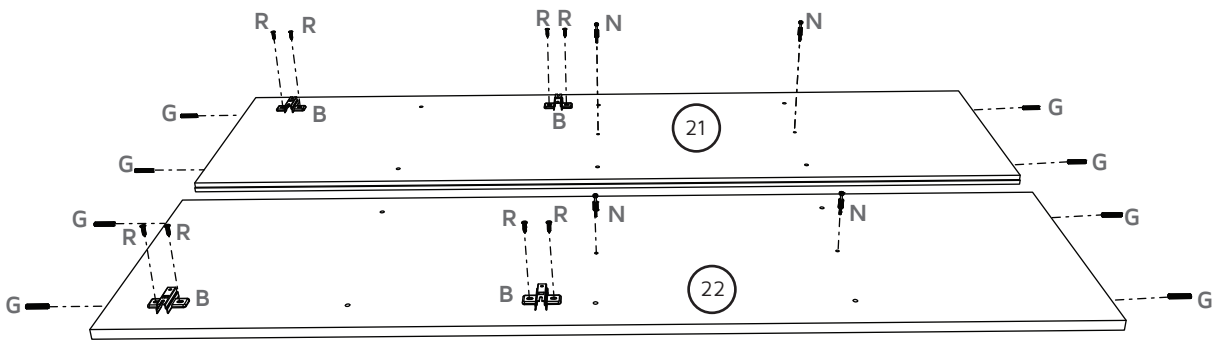

03

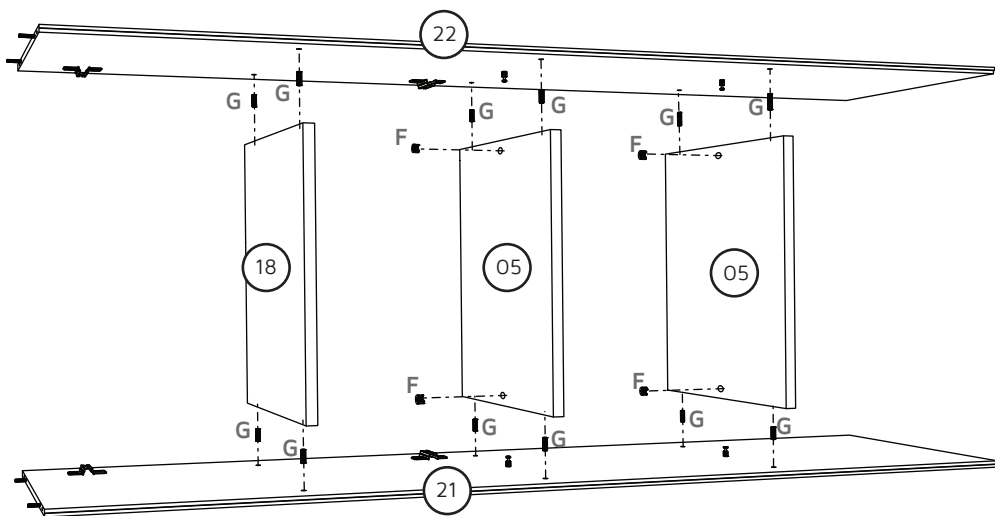

04

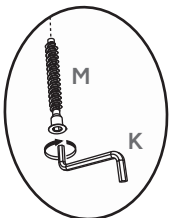
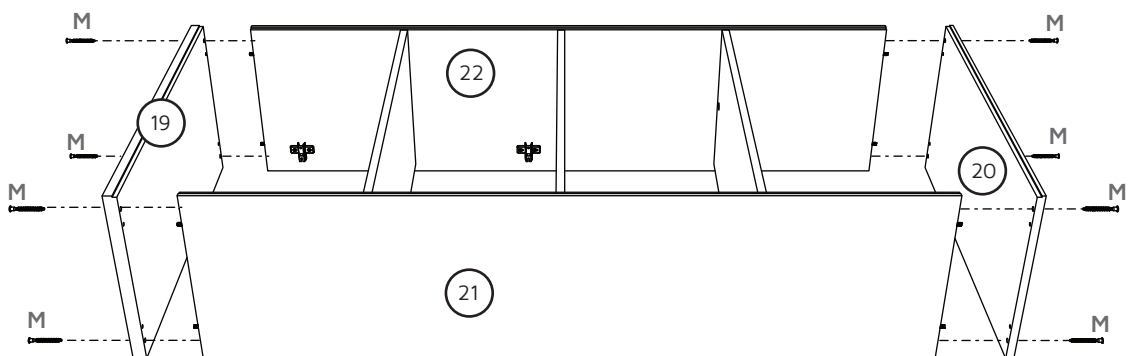

05

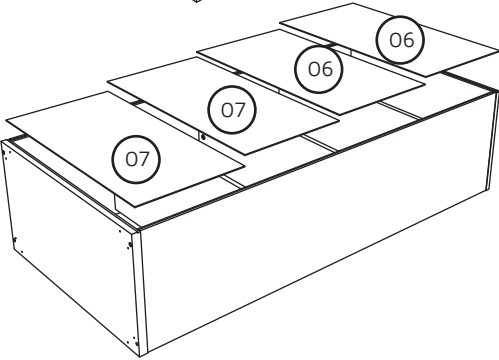
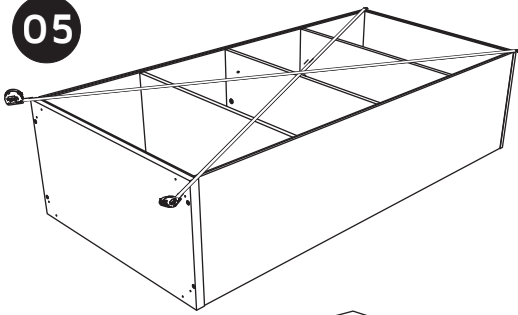

*Antes de pregar o fundo verifique o perfeito esquadro para evitar problemas de alinhamento na instalação.

*Before nailing the backplate, set it square to avoid alignment problems in the assembly.

*Antes de clavar el fondo confirmar la plaza perfecta para evitar problemas de alineación en la instalación.

*Avant de clouer le fond, vérifiez l'alignement parfait pour éviter des problèmes pendant l'installation.

*Überprüfen Sie vor der Befestigung der Rückwand den Winkel, um Ausrichtungsprobleme zu vermeiden.

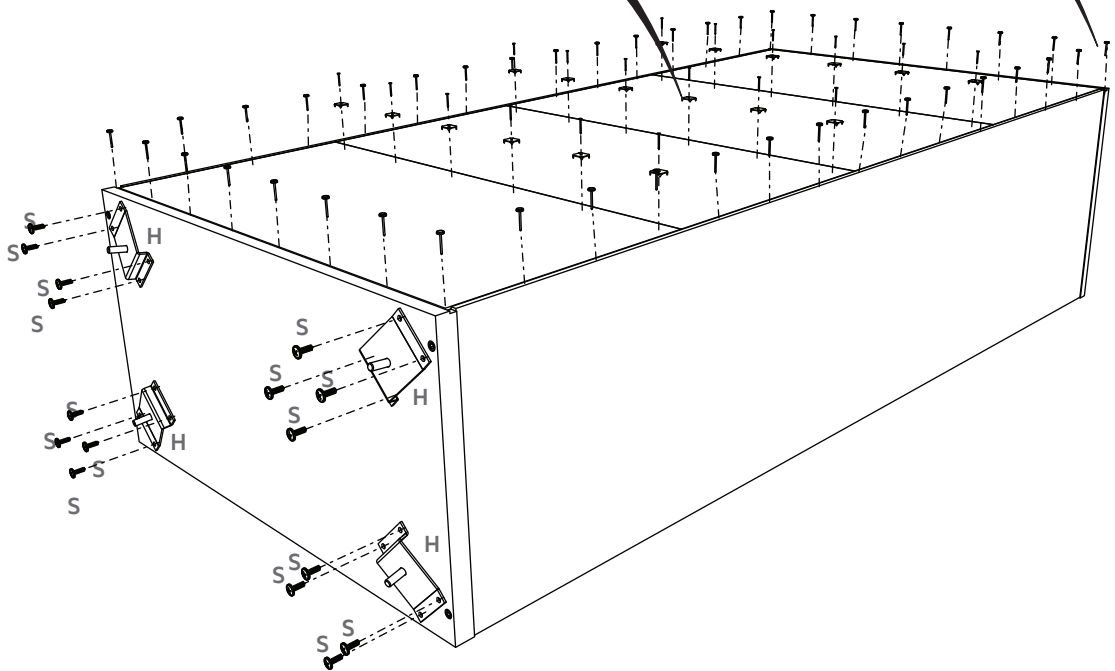
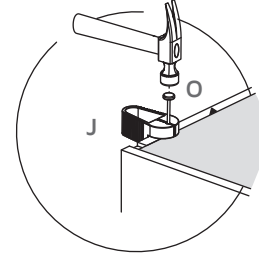
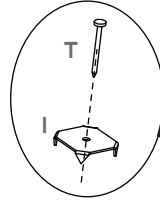

Posicionar usando furo guia.
Place them using pilot hole.
Posicionar usando agujero piloto.
Positionnez à l'aide du trou de guidage.
Mit dem Führungsloch positionieren.

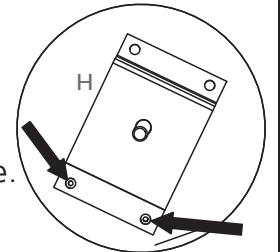

06

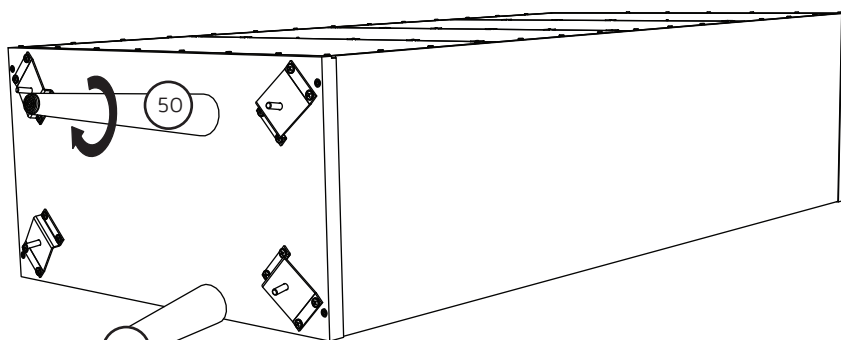
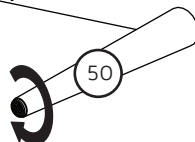
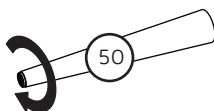
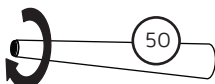

07

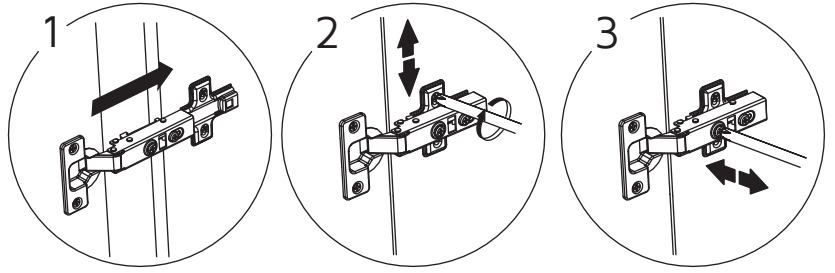
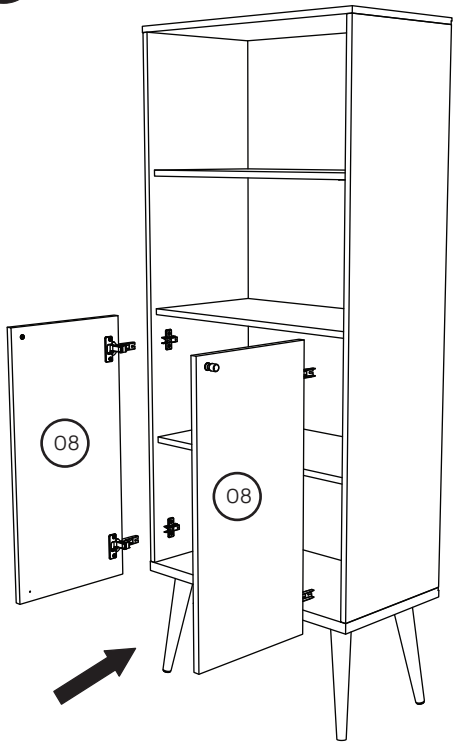

08

É obrigatório fixar este acessório de segurança.

It's mandatory to fix this safety device.

Es obligatorio fijar este dispositivo de seguridad.

Il est obligatoire de fixer cet accessoire de sécurité.
Dieses Sicherheitszubehör muss angebracht werden.

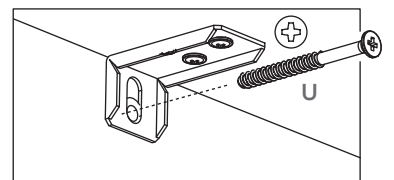
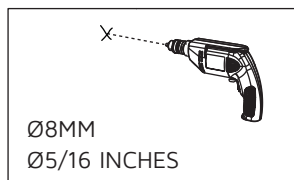
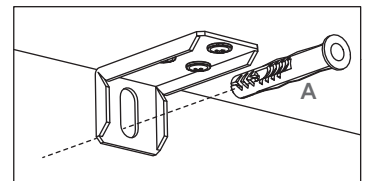
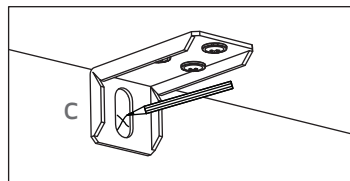
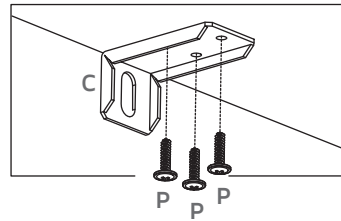
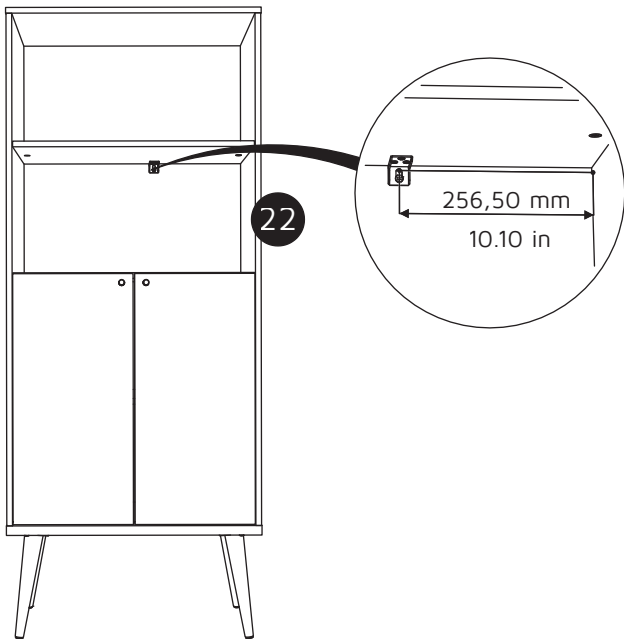

09

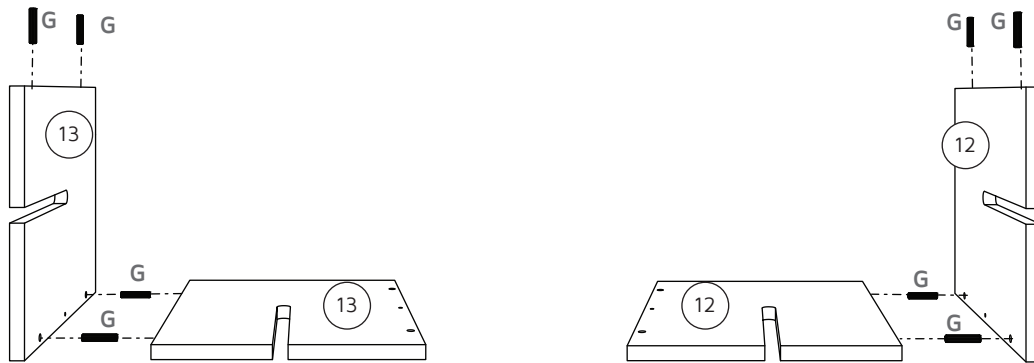

10

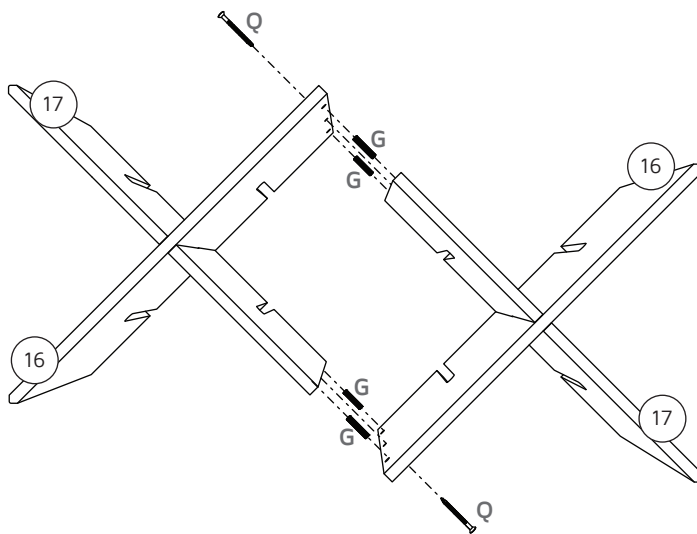

11

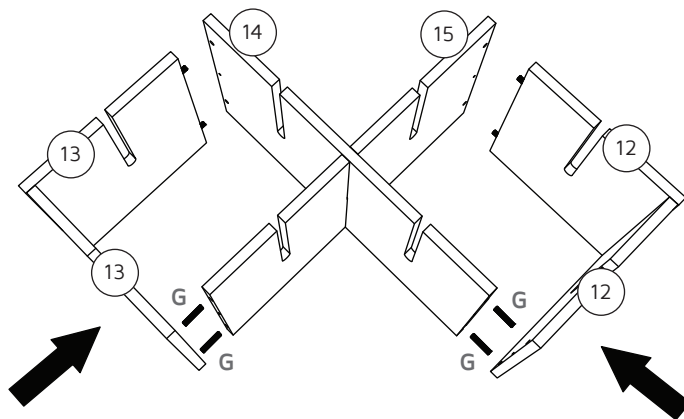

12

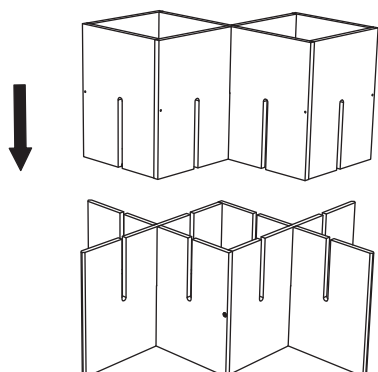

13

