

# **BODYCRAFT**

## **GX STRENGTH TRAINING SYSTEM INSTRUCTION MANUAL MODEL BCG-GX**

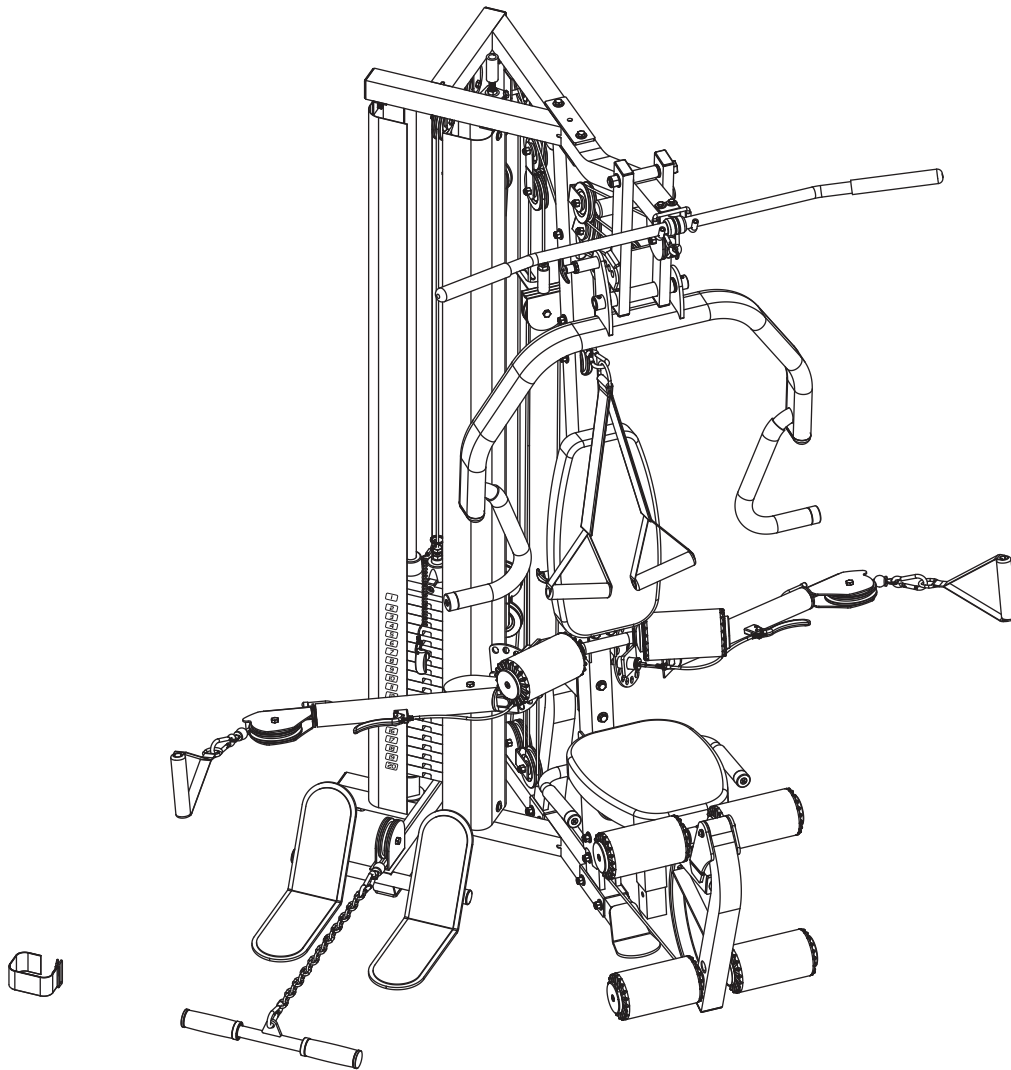

### ***QUESTION?***

*As a quality home gym supplier we are committed to your complete satisfaction. If you have questions, or find missing or damaged parts, we will guarantee your complete satisfaction through our authorized dealer service centers or our home office customer service department. Please call your local dealer for assistance or BodyCraft at 800-990-5556 (9:00 AM - 5:00 PM). Our trained technicians will provide immediate assistance to you, free of charge.*

Bodycraft is a division of Recreation Supply Inc.  
P.O. BOX 181  
Sunbury, OH 43074

**MZ6881**

## **BEFORE YOU BEGIN**

Congratulations and thank you for selecting the **BODYCRAFT GX** strength training system. The **BODYCRAFT GX** offers an impressive array of strength training exercises to develop every major muscle group of the body.

Whether your goal is cardiovascular fitness, a shapely, toned body or dramatic muscle size and strength, the **BODYCRAFT GX** will help you achieve the specific results you want.

**For your safety and benefit, read this manual and the accompanying literature before using the BODYCRAFT GX.** Keep this manual for future reference. If you have additional questions, please call your local **BODYCRAFT** dealer or our customer service department at 800-990-5556 Monday through Friday, 9 a.m. until 5 p.m. Eastern Time.

## **IMPORTANT SAFETY NOTES**

**There is a risk assumed by individuals who use this type of equipment. Before beginning this or any other exercise program consult your physician. This is especially important for individuals over the age of 35 or persons with pre-existing health problems. Recreation Supply, Inc. assumes no responsibility for personal injury or property damage sustained by or through use of this product.**

1. This product must be assembled on a flat, level surface to assure its proper function.
2. Clean pads and frame on a regular basis. We recommend warm, soapy water. Do not use harsh or abrasive chemicals.
3. Inspect and tighten all parts before every use. Replace any worn parts immediately. Failure to do so may result in serious injury.
4. Keep children away from the **BODYCRAFT GX** at all times.
5. Keep your hands away from cables and pulleys during operation. Keep your hands away from moving parts other than the designated handles.
6. When adjusting the seat, make sure the spring pin is fully engaged. If not, the seat may slip and cause serious injury.
7. Make certain all cables are seated within the pulleys before every use.
8. Exercise with care to avoid injury.
9. If unsure about the proper use of the **BODYCRAFT GX** strength training system call your local **BODYCRAFT** dealer or our customer service department at 800-990-5556.

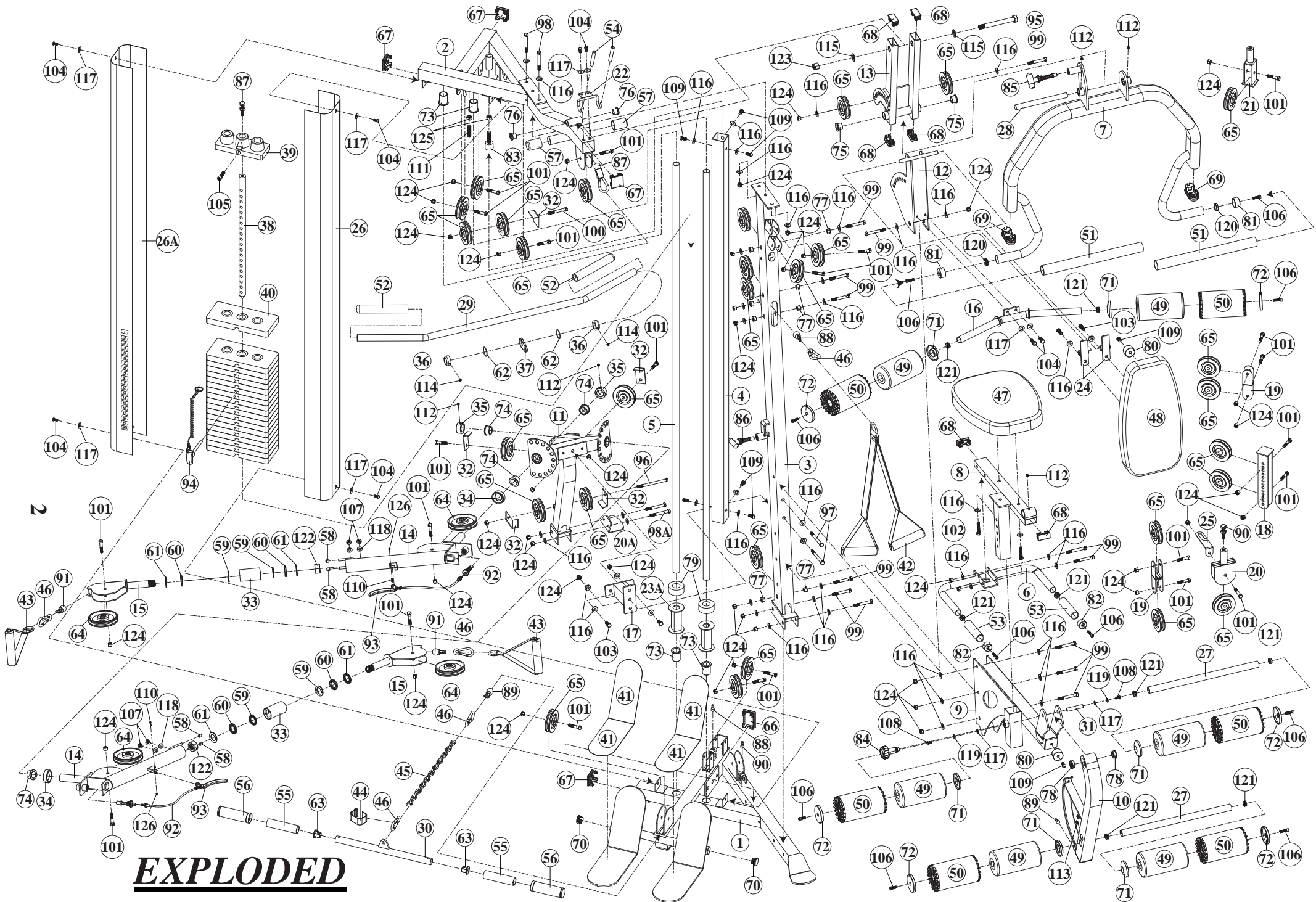

***EXPLODED***

# PARTS LIST

NO.	DESCRIPTION	QTY.
1	BASE FRAME	1
2	TOP FRAME	1
3	FRONT UPRIGHT	1
4	REAR UPRIGHT	1
5	GUIDE ROD	2
6	LEG EXTENSION HANDLE	1
7	PRESS ARM	1
8	SEAT ADJ. FRAME	1
9	SEAT FRAME	1
10	LEG EXTENSION ARM	1
11	CABLE ARM ASSEMBLY	1
12	SEAT BACK ADJUSTER	1
13	PRESS ARM SUPPORT	1
14	CABLE ARM	2
15	SWIVEL CABLE ARM END	2
16	LEG HOLDER	1
17	CABLE ARM CONNECTOR	1
18	ADJUSTABLE PULLEY BLOCK	1
19	DOUBLE PULLEY BLOCK	2
20	ADJ FLOATING PULLEY BLOCK	1
20A	FOOT PLATE	1
21	FLOATING PULLEY BLOCK	1
22	LAT BAR HOLDER	1
23	150LBS LONGER STACK SPACER	2
23A	200LBS SHORTER STACK SPACER	2
24	METAL HINGE	2
25	CABLE GUIDE PLATE	1
26	WEIGHT SHROUD	1
26A	WEIGHT SHROUD WITH NUMBER	1
27	1" FOAM ROLLER HOLDER	2
28	PRESS ARM AXLE	1
29	LAT BAR	1
30	CURL BAR	1
31	LEG EXTENSION AXLE	1
32	PULLEY GUIDE BRACKET	5
33	CABLE ARM COLLAR	2
34	STEEL SPACER	2
35	AXLE COLLAR	2
36	COLLAR	2
37	HOOK PLATE	1
38	SELECTOR ROD	1
39	TOP PLATE	1
40	WEIGHT PLATE	19

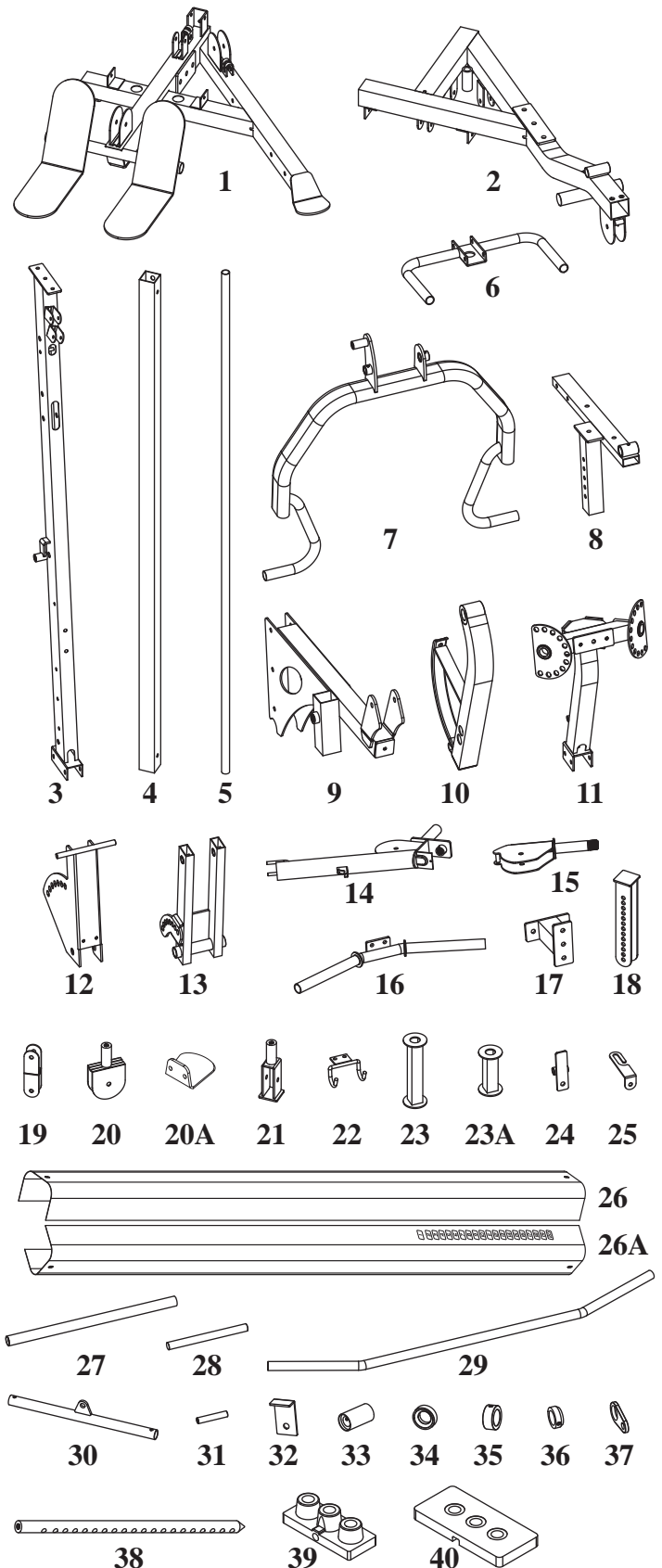





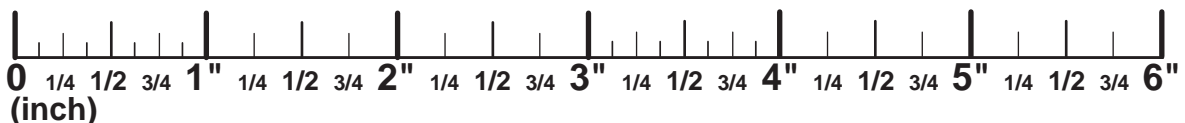



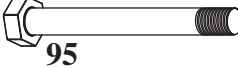





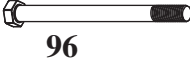





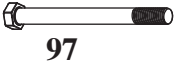





















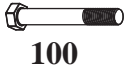









# PARTS LIST

NO.	DESCRIPTION	QTY.
41	NONSLIP	4
42	AB CRUNCH	1
43	SINGLE HANDLE	2
44	ANKLE STRAP	1
45	LINK	1
46	CLIP	5
47	SEAT PAD	1
48	BACK PAD	1
49	FOAM PAD	6
50	COVER OF FOAM PAD (all pre-assembled)	6
51	1-1/4" X 430mm HAND GRIP	2
52	1" X 200mm ROUND HAND GRIP	2
53	1" X 95mm HAND GRIP (all pre-assembled)	2
54	LAT BAR HOLDER COVER	2
55	1-1/4" X 140mm ROUND HAND GRIP	2
56	1-1/4" HAND GRIP (all pre-assembled)	2
57	1" X 70mm HAND GRIP (all pre-assembled)	2
58	CABLE ARM STOPPER (all pre-assembled)	4
59	BEARING BASIN (all pre-assembled)	4
60	BEARING (all pre-assembled)	4
61	BEARING COVER (all pre-assembled)	4
62	SEALING RING (all pre-assembled)	2
63	1" T SHAPE END PLUG	2
64	114mm PULLEY	4
65	90mm PULLEY	29
66	50 X 75mm RECT. END CAP	1
67	50mm SQ. END CAP	4
68	25 X 50mm RECT. END CAP	6
69	40 X 80mm OVAL PLUG	2
70	1-1/4" ROUND END PLUG	2
71	PLASTIC COVER	6
72	PLASTIC WASHER	6
73	1" ID PLASTIC GUIDE ROD HOLDER	4
74	1" ID STEEL BUSHING (all pre-assembled)	4
75	3/4" ID BUSHING (all pre-assembled)	2
76	5/8" ID BUSHING (all pre-assembled)	2
77	3/8" ID BUSHING	8
78	LEG EXTENSION BEARING	2
79	RUBBER CUSHION	2
80	1/2" STOPPER (all pre-assembled)	2
81	PRESS ARM STOPPER	2
82	SEAT PAD SUPPORT STOPPER	2
83	RUBBER STOPPER (all pre-assembled)	1
84	LOCKING SPRING KNOB	1
85	LONGER RED POP PIN	1
86	SHORTER RED POP PIN	1
87	TOP CABLE	1
88	AB CRUNCH CABLE	1
89	LOWER CABLE	1
90	CONNECT CABLE	1
91	CABLE ARM CABLE	1
92	CLUTCH CABLE	2
93	CLUTCH LEVER OF CABLE ARM	2
94	SELECTOR PIN	1



# PARTS LIST

NO.	DESCRIPTION	QTY.						
95	5/8" X 5-1/2" HEX BOLT	1						
96	3/8" X 4-3/4" HEX BOLT	1						
97	3/8" X 4" HEX BOLT	2						
98	3/8" X 3-1/8" HEX BOLT	2						
98A	3/8" X 3-1/4" HEX BOLT	2						
99	3/8" X 3" HEX BOLT	13						
100	3/8" X 2-3/4" HEX BOLT	1						
101	3/8" X 1-3/4" HEX BOLT	23						
102	3/8" X 1-3/4" HEX THREADED BOLT	2						
103	3/8" X 1" HEX THREADED BOLT	4						
104	5/16" X 1/2" ROUND BOLT	8						
105	TOP PLATE BOLT	1						
106	5/16" X 1-1/4" SUNKEN HEAD SCREW	10						
107	3/8" X 1/2" ROUND BOLT (all pre-assembled)	4						
108	5/16" X 5/8" SET SCREW (all pre-assembled)	2						
109	3/8" X 3/4" INNER HEX SCREW (all pre-assembled)	8						
110	M5 X 18mm ROUND HEAD SCREW	2						
111	1/2" SET SCREW (all pre-assembled)	1						
112	5/16" X 1/4" SET SCREW (all pre-assembled)	5	<b>115</b>	<b>116</b>	<b>117</b>	<b>118</b>	<b>119</b>	
113	5/16" X 1/2" SET SCREW (all pre-assembled)	2						
114	M6 SET SCREW	2	<b>120</b>	<b>121</b>	<b>122</b>	<b>123</b>	<b>124</b>	
115	5/8" WASHER	2						
116	3/8" WASHER	50						
117	5/16" WASHER	10	<b>125</b>	<b>126</b>	<b>127</b>	<b>128</b>		
118	3/8" SPRING WASHER (all pre-assembled)	4						
119	5/16" SPRING WASHER (all pre-assembled)	2						
120	5/16" LARGER NUT (all pre-assembled)	2						
121	5/16" SMALLER NUT (all pre-assembled)	8						
122	24mm NYLON NUT (all pre-assembled)	2						
123	5/8" NYLON NUT	1						
124	3/8" NYLON NUT	44						
125	1/2" NUT (all pre-assembled)	2						
126	M5 NUT	2						
127	4mm HEX WRENCH	1						
128	5mm HEX WRENCH	1						



# STEP 1 ASSEMBLE BASE FRAME

*To ease the assembly process, Do Not tighten bolts until instructed.*

1. Attach Front Upright (3) to Base Frame (1), using two 3/8" X 3" Hex Bolts (99), four 3/8" Washers (116) and two 3/8" Nuts (116).

2. Attach Rear Upright (4) to Base Frame (1), using three 3/8" X 3/4" Hex Screws (109) and three 3/8" Washers (116).

3. Insert two 1" ID Plastic Guide Rod Holders (73) into the holes on the Base Frame (1). Insert the Guide Rods (5) into the 1" ID Plastic Guide Rod Holders (73). Slide the 200Lbs Stack Spacers (23A) onto the guide rods, followed by the Rubber Cushions (79).

**Important: If you have purchase the optional 200Lbs pound weight stack, please use the 200Lbs Shorter Stack Spacers (23A) in place of the 150Lbs Longer Stack Spacers (23).**

4. Slide the Weight Plates (40) onto the Guide Rods (95), making sure to orient the selector holes toward the front and bottom. Attach the Top Plate (39) to the Selector Rod (38) using the Top Plate Bolt (105). Tighten the Top Plate Bolt (105) using a hex key. Slide the Top Plate onto the guide Rods, running the Selector Rod (94) down through the center holes of the Weight Plates (40).

5. Install the plastic end caps as shown. Insert the two 1-1/4" Round End Plugs (70) into the ends of the round Foot Plate Tube. Insert one 50 X 75mm Rect. End Cap (66) into the rear of the Base Frame (1). Insert one 50mm Sq. End cap into the side of the Base Frame (1).

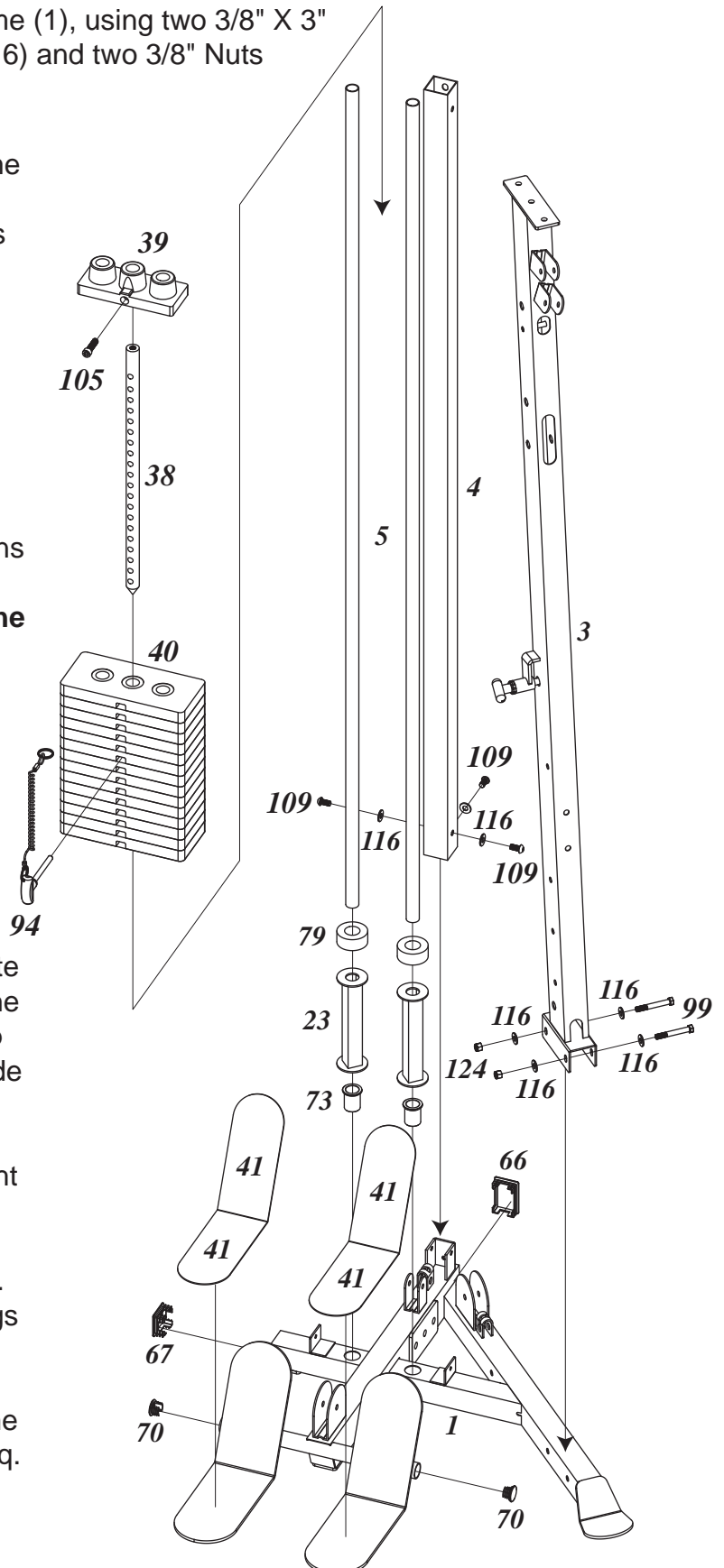

## STEP 2 ASSEMBLE TOP FRAME

1. Insert two 1" ID Plastic Guide Rod Holders (73) into the holes on the Top Frame (2). Place Top Frame (2) on top, making sure to insert the Guide Rods (5) and Rear Upright (4).
2. Attach Top Frame (2) to Rear Upright (4), using three 3/8" X 3/4" Hex Screws (109) and three 3/8" Washers (116).
3. Attach the Top Frame (2) to the Front Upright (3) using two 3/8" X 3-1/8" Hex Bolts (98), four 3/8" Washers (116), and two 3/8" Nylon Nuts (124).
4. Attach Lat Bar Holder (22) to Top Frame (2), using two 5/16" X 1/2" Round Bolts (104) and two 5/16" Washers (117).
5. Install the plastic end caps as shown. Insert three 50mm SQ. End Caps (67) to each end of the Top Frame (2).

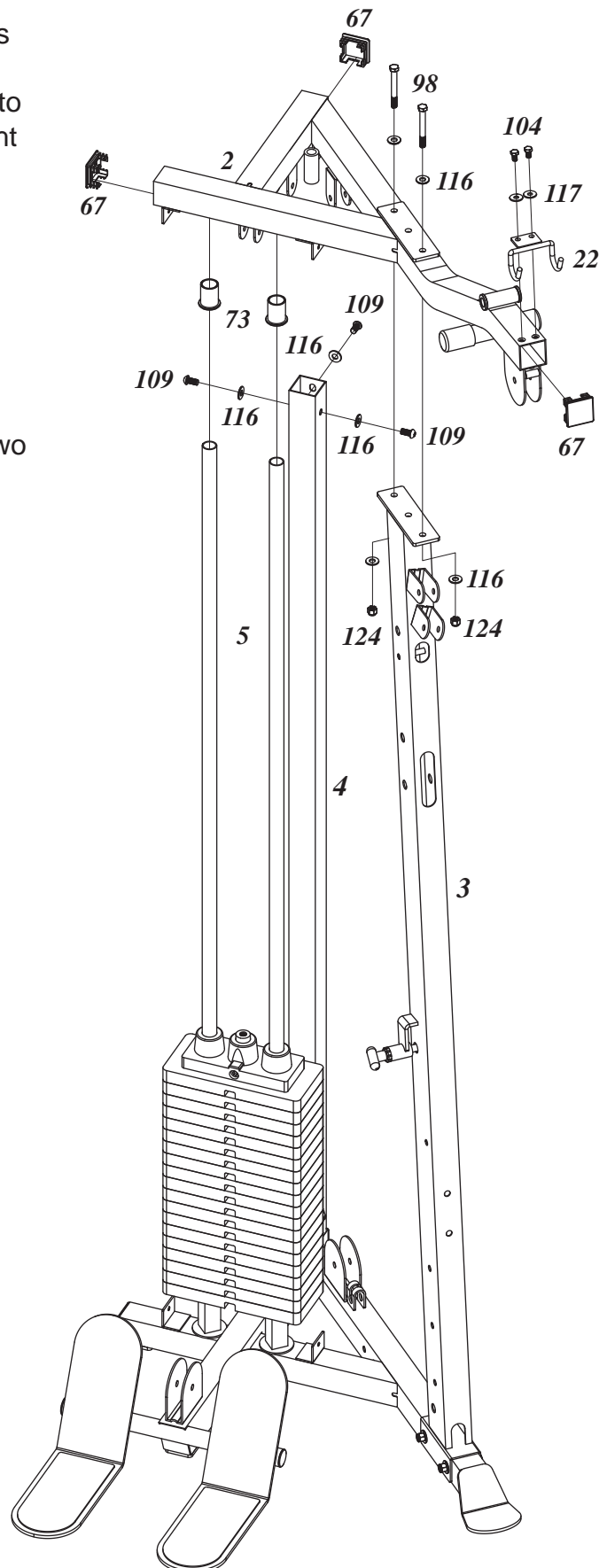



# STEP 3 ASSEMBLE CABLE ARM ASSEMBLY

*Remember to keep all BOLTS loose to ensure the holes will align easily.*

1. Attach Cable Arm Assembly (11) to Cable Arm Connector (17), using two 3/8" X 1" Hex Bolts (103) and two 3/8" Washers (116) then attach Cable Arm Connector (17) to Front Upright (3), using two 3/8" X 4" Hex Bolts (97), four 3/8" Washers (116) and two 3/8" Nylon Nuts (124).
2. Attach Cable Arm Assembly (11) and Stabilizing Plate (20A) to Base Frame (1), using two 3/8" X 3-1/4" Hex Bolts (98A), four 3/8" Washers (116) and two 3/8" Nylon Nuts (124). You may need to loosen the bolts at the top of the Cable Arm Frame to help the holes line up.
3. Slide the axle of each Cable Arm (14) through the holes on the selector plate in The Cable Arm Assembly (11) and then fasten using the Steel Spacer (34), and Axle Collars (35). Tighten the set screw on the Axle Collars (35) with a 5/16" Allen Wrench. Check to ensure that each Cable Arm (14) pivots freely and that cables are not twisted.

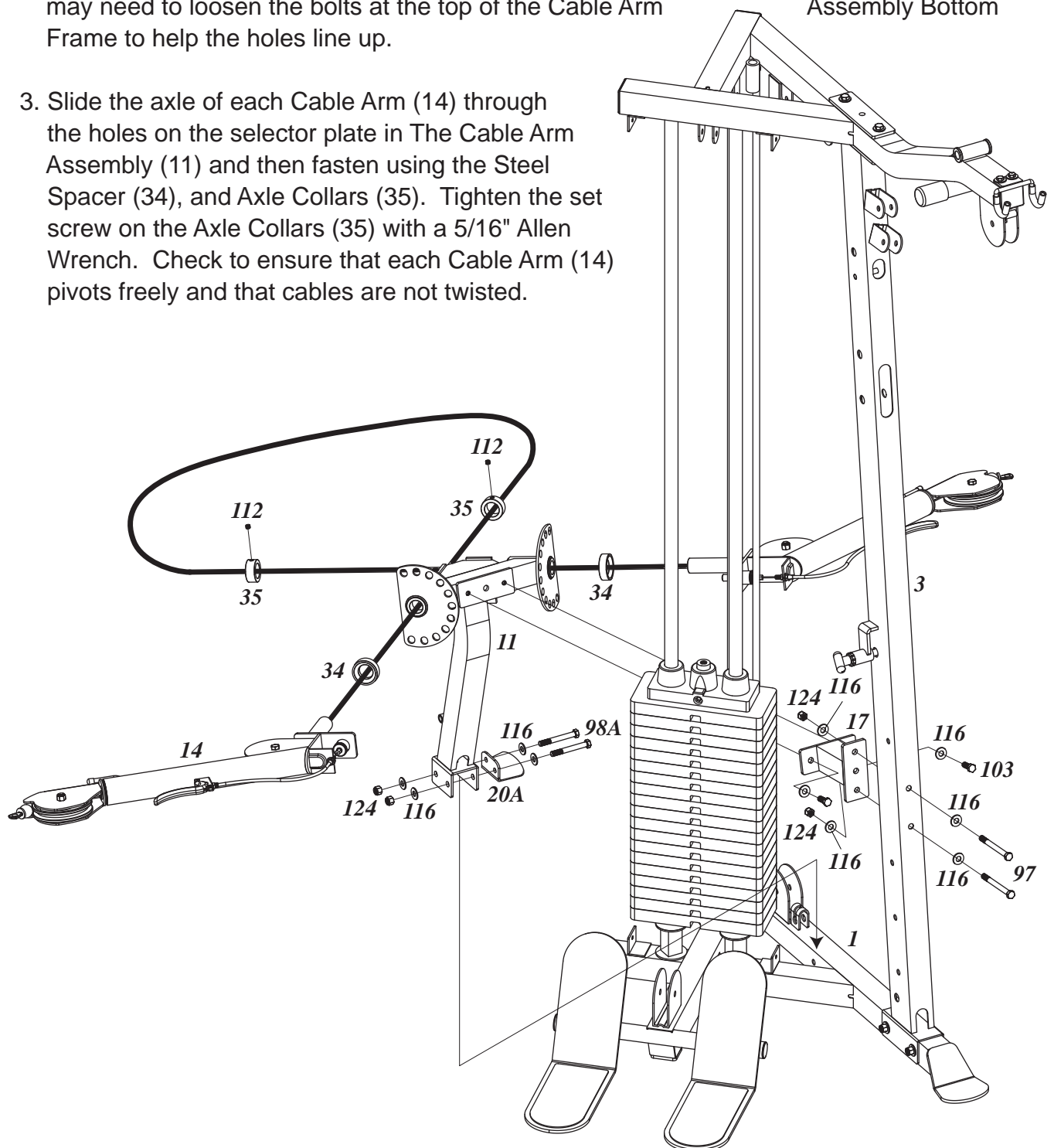

# STEP 4 ASSEMBLE PRESS STATION

1. Attach Press Arm Support (13) to the Top Frame (2) by aligning the holes and inserting the 5/8" X 5-1/2" Hex Bolt (95) with two 5/8" Washers (115) and one 5/8" Nylon Nut (123).
2. Attach four 25 X 50mm Rect. End Caps (68) to Press Arm Support (13).
3. Attach Press Arm (7) to the Press Arm Support (13) by aligning the holes and inserting the Press Arm Axle (28). Tighten the pre-installed 5/16"X 1/4" Set Screws (112) on the Press Arm (7). Make sure the Longer Red Pop Pin (85) is seated in one of the adjustment holes on the Press Arm Support (13).

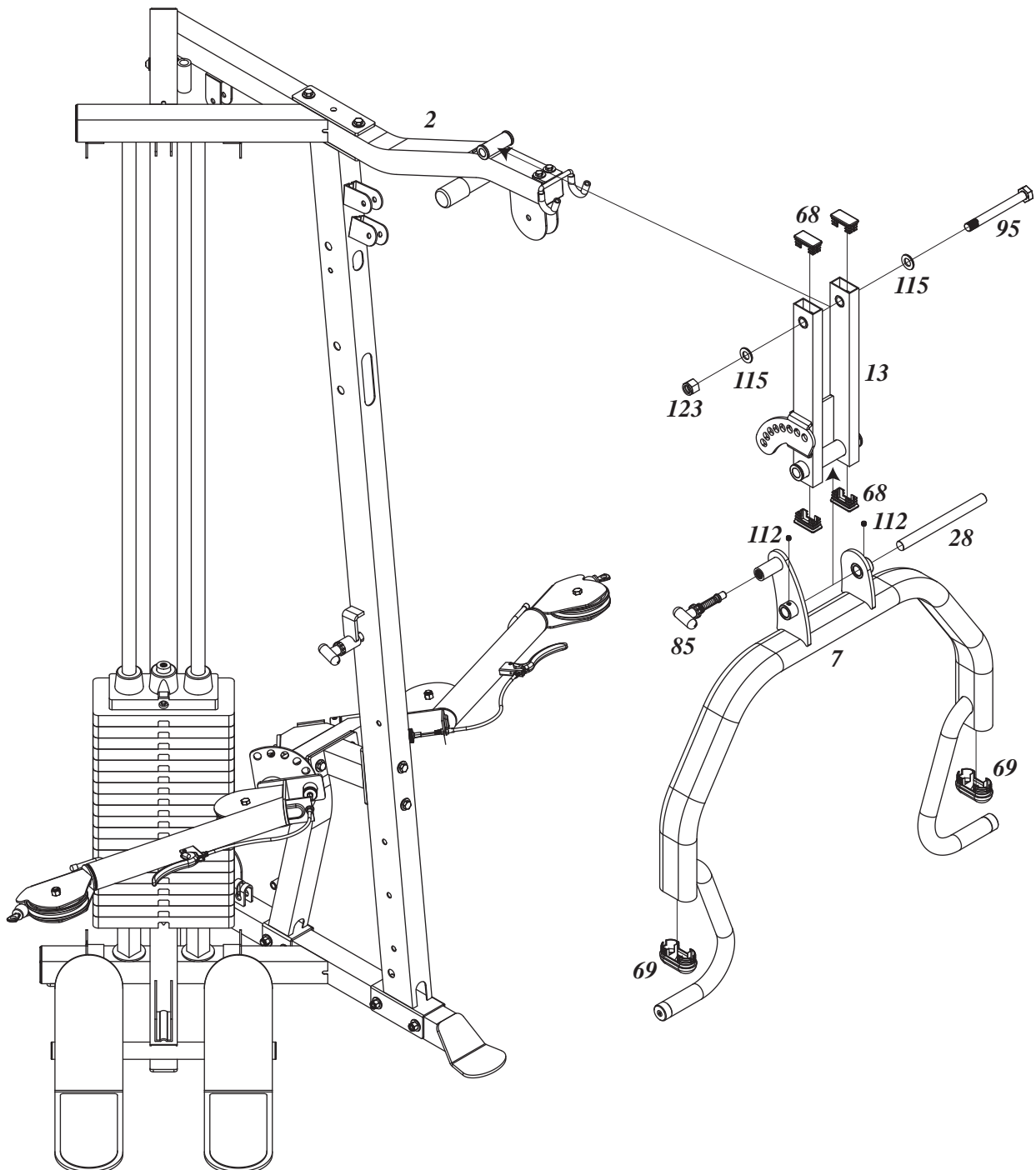

# STEP 5 ASSEMBLE SEAT FRAME AND SEAT & BACK PAD

1. Attach Seat Frame (9) to Front Upright (3), using three 3/8" X 3" Hex Bolts (99) six 3/8" Washers (116) and three 3/8" Nylon Nuts (124).
  2. Attach Seat Back Adjuster (12) to Front Upright (3), using one 3/8" X 3" Hex Bolt (99), two 3/8" Washers (116) and one 3/8" Nylon Nut (124). It may be necessary to tighten this bolt, then loosen just enough to let Seat Back Adjuster (12) pivot FREELY. Longer Red Pop Pin (85) should seat into adjustment holes in Seat Back Adjuster (12).
  3. Attach Leg Holder (16) to Seat Back Adjuster (12), using two 5/16" X 1/2" Round Hex Bolt (104) and two 5/16" Washers (117). Tighten these screws.
  4. Slide the two Metal Hinges (24), holes at bottom, onto the axle welded to the top of the Seat Back Adjuster (12), then attach the Back Pad (48) to the Metal Hinges using two 3/8" X 1" Hex Threaded Bolts (103), and two 3/8" Washers (116).
  5. Attach Leg Extension Handle (6) to Seat Adj. Frame (8), using two 3/8" X 3" Hex Bolts (99), four 3/8" Washers (116) and two 3/8" Nylon Nuts (124). Attach Seat Pad (47) to Seat Adj. Frame (8), using two 3/8" X 1-3/4" Hex Bolts (102) and two 3/8" Washers (116).
  6. Insert a 25 X 50mm Rect. End Plug (68) into each end of the Seat Adj. Frame (8) and then slide the Seat Adj. Frame (8) into the Seat Frame (9). The Seat Adj. Frame (8) is held in place by a Locking Spring Knob (84).
  7. Attach Leg Extension Arm (10) to Seat Frame (9), by inserting Leg Extension Axle (31). Fasten Leg Extension Axle (31) using two 5/16" X 5/8" Set Screws (108), two 5/16" Spring Washers (119), and two 5/16" Washers (117).
  8. Insert a Foam Roller Holder (27) into the tube on the chrome Seat Adj. Frame (8). Slide a Plastic Cover (71) onto the Foam Roller Holder (27), flat side to the outside. Then slide a Foam Pad (49) onto the Foam Roller Holder (27), flat side to the outside. Cover with an Aluminum Cap (72) and secure with a 5/16" X 1-1/4" Sunken Head Screw (106). Repeat for the other side.
- Repeat this process for Foam Pads (49) on Leg Extension Arm (10) and Leg Holder (16).

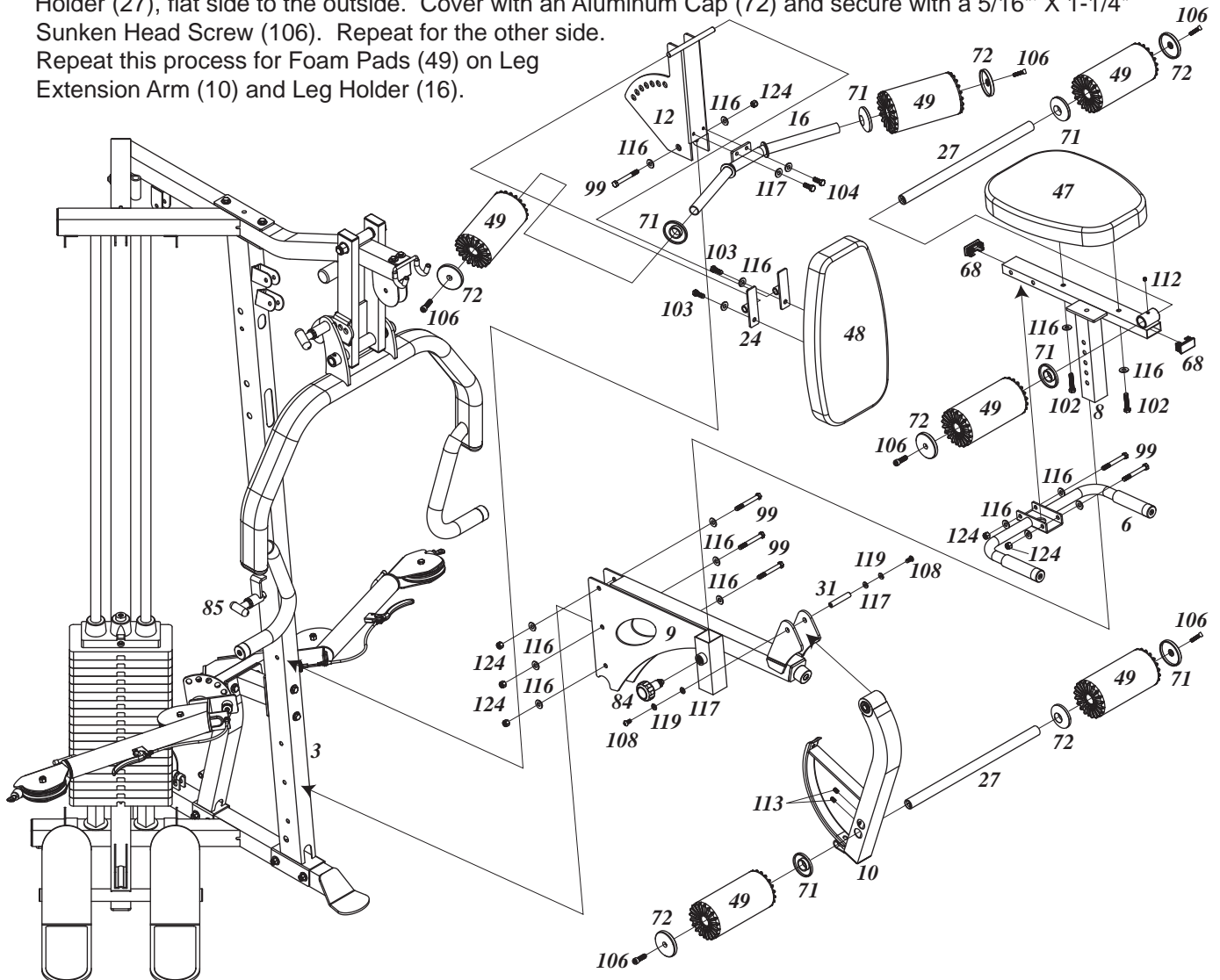

## STEP 6 INSTALL TOP CABLE

***Pulleys T3 and T5 are mounted to either side of the steel tab. Do not mount both pulleys to one side. Assemble cables and pulleys simultaneously***

1. Grab the threaded end of the Top Cable (87). Run the cable over a Pulley T1 you will mount at the front of the Top Frame (2) using one 3/8" X 1-3/4" Hex Bolt (101) and one 3/8" Nylon Nut (124), as shown in Fig T1.
2. Run the cable back to a pulley you will mount on the Front Upright (T2) using one 3/8" X 1-3/4" Hex Bolt (101) and one 3/8" Nylon Nut (124). Run the cable over top this pulley, exiting on the underside.
3. Run the cable forward to the Press Arm Support (13). You will mount two pulleys side-by-side here using one 3/8" X 3" Hex Bolt (99), two 3/8" Washers (116), and one 3/8" Nylon Nut (124). Route the cable to the top of Pulley T3 (T3 is the pulley on the right side, as if sitting on the seat), around T3 to underside of T4. T4 is mounted to the Front Upright (3) using one 3/8" X 1-3/4" Hex Bolt (101) and one 3/8" Nylon Nut.
4. Continue routing the cable entering the underside of T4, exiting on top and on then forward to T5, which is the left side pulley mounted in Press Arm Support (13). Run the cable over top of pulley T5, exiting on the underside.
5. Route cable to Pulley T6, which you will mount inside the Front Upright (3) using one 3/8" X 3" Hex Bolt (99), two 3/8" Washers (116), two 3/8" ID Bushings (77), and one 3/8" Nylon Nut (124). Run the cable on the underside of this Pulley T6.
6. Route cable over top of Pulley T7 you will mount in the rear bracket on the Top Frame (2) using one Longer 3/8" X 2-3/4" Hex Bolt (100) and one 3/8" Nylon Nut (124).
7. Mount a pulley in the closed end of the Adjustable Pulley Block (18) using one 3/8" X 1-3/4" Hex Bolt (101) and one 3/8" Nylon Nut (124). Hang this Adjustable Pulley Block (18) by routing the cable to the underside of the pulley as shown in T8. Continue routing the cable over top of Pulley T9, which you will mount to Top Frame (2) using one 3/8" X 1-3/4" Hex Bolt (101) and one 3/8" Nylon Nut (124).
8. Then run the cable through the Floating Pulley Block (21). Orient the Floating Pulley Block (21) with the threaded end up, flat side down. Threaded installed 1/2" Set Screw (111) to bracket welded on Top Frame (2). Insert a pulley into the Floating Pulley Block (21), making sure the cable runs to the underside. Secure the pulley using one 3/8" X 1-3/4" Hex Bolt (101) and one 3/8" Nylon Nut (124). If you purchased option Leg Press at same time, please orient the Floating Pulley Block (21), with the threaded end down, flat side up as Leg Press manual.
9. Route the cable over Pulley T11 mounted to the Top Frame (2) using one 3/8" X 1-3/4" Hex Bolt (101) and one 3/8" Nylon Nut (124).
10. Run the cable through the looped end of the selector pin lanyard, and then screw the threaded end of the top cable into the top plate, about half way down. The threaded end of the cable is an adjustment point but should always have at least one third of the threads screwed into the top plate.

# STEP 6 INSTALL TOP CABLE

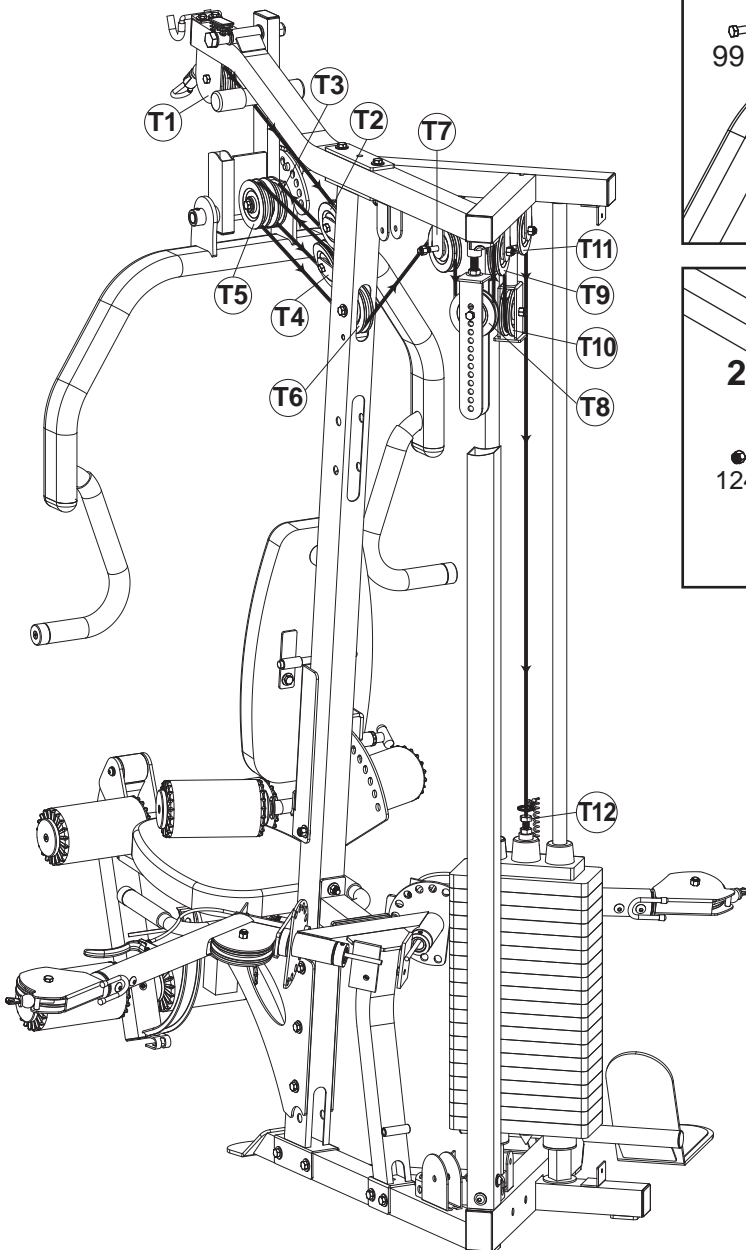
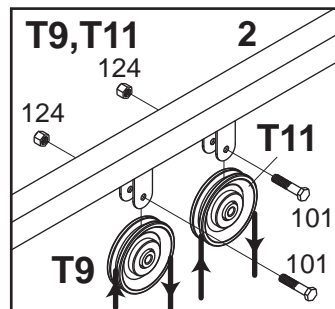
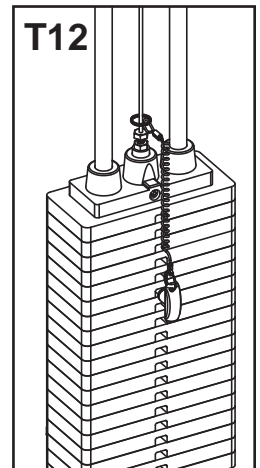
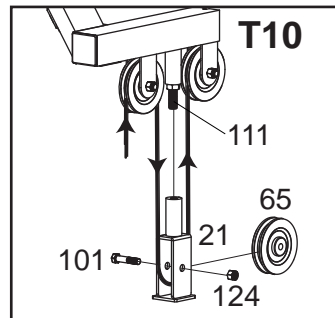
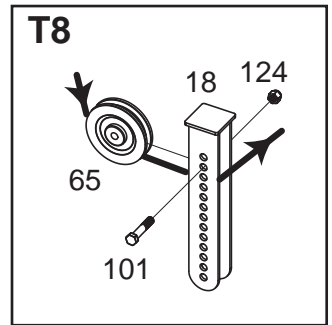
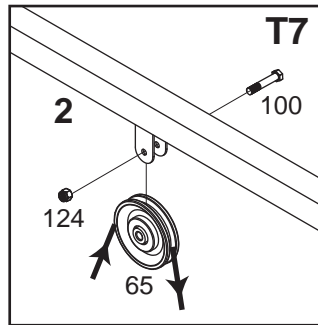
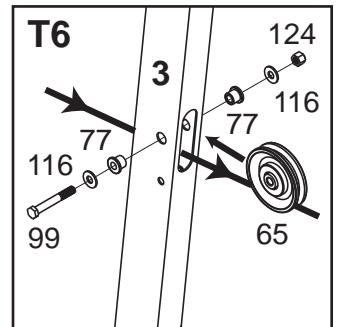
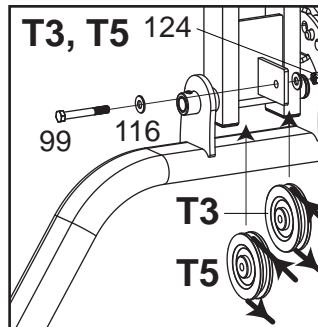
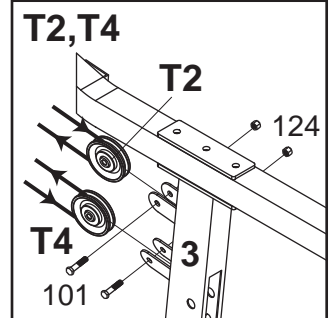
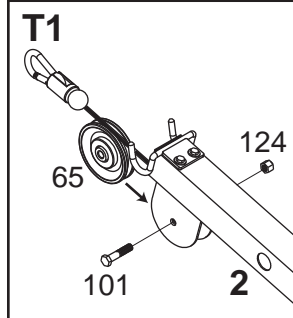
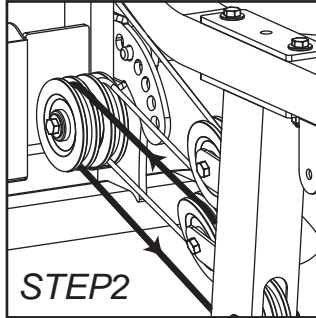
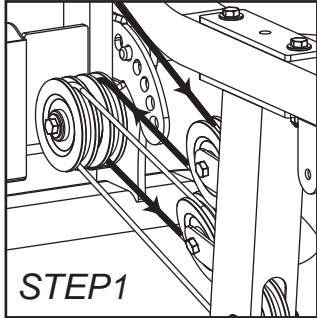

# STEP 7 INSTALL AB CABLE

1. Run the steel ball end of the Ab Cable (88) through the slot in the Front Upright (3) and attach two pulleys in the slot as shown in Fig. A1, using two 3/8" X 3" Hex Bolts (99), four 3/8" Washers (116), four 3/8" ID Bushings (77), and two 3/8" Nylon Nuts (124). The cable should run from the bottom of the upper pulley in A1 up to the Pulley A2.
2. Route the cable over the Pulley A2 mounted to the Top Frame (2) using one 3/8" X 1-3/4" Hex Bolt (101) and one 3/8" Nylon Nut (124).
3. Then route the cable under Pulley A3 mounted in a Double Pulley Block (19) using one 3/8" X 1-3/4" Hex Bolt (101) and one 3/8" Nylon Nut (124).
4. Continue routing the cable up and over Pulley A4 mounted in Top Frame (2) using assembled one 3/8" X 2-3/4" Hex Bolt (100) as T7, one 3/8" Nylon Nut (124), and Pulley Guide Bracket (32).
5. Then route the cable under Pulley A5 mounted in a Double Pulley Block (19) using one 3/8" X 1-3/4" Hex Bolt (101) and one 3/8" Nylon Nut (124).
6. Mount a pulley in the open end of the Adjustable Pulley Block (18) using one 3/8" X 1-3/4" Hex Bolt (101) and one 3/8" Nylon Nut (124). We recommend the third from bottom hole. This can be adjusted later if needed. Route the cable over top of this pulley and then down to c.

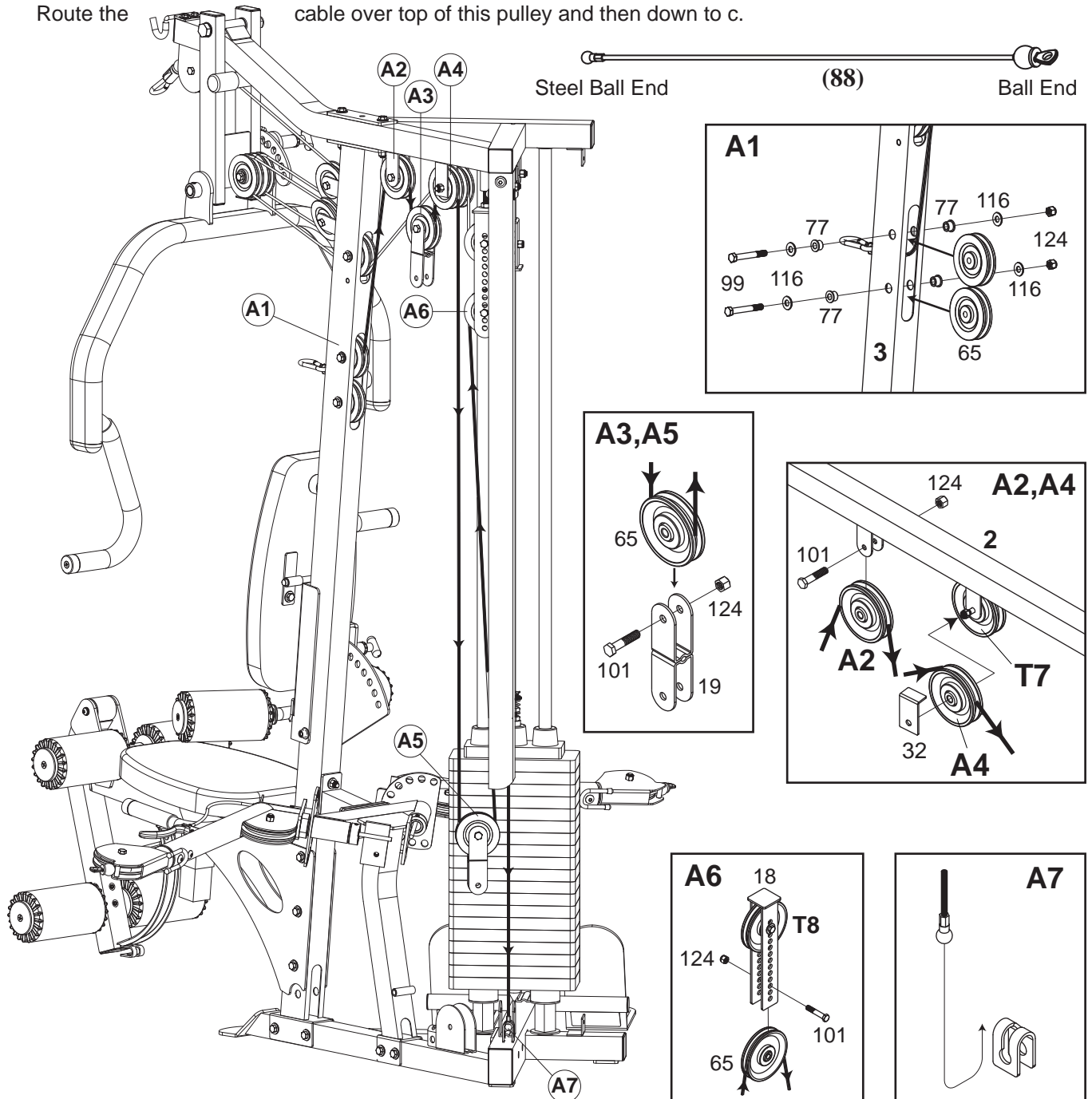

# STEP 8 INSTALL LOWER CABLE

1. Route the steel ball end of the Lower cable (89) under Pulley L1 mounted at the front of the Low Pull Station using one 3/8" X 1-3/4" Hex Bolt (101) and one 3/8" Nylon Nut (124).
2. Continue back to Pulley L2 mounted on the Base Frame (1) using one 3/8" X 1-3/4" Hex Bolt (101) and one 3/8" Nylon Nut (124). Route the cable underneath L2 and then up to Pulley L3 mounted in bottom of the Double Pulley Block (19) using one 3/8" X 1-3/4" Hex Bolt (101) and one 3/8" Nylon Nut (124).
3. Continue down to Pulley L4 mounted to the Base Frame (1) using one 3/8" X 1-3/4" Hex Bolt (101) and one 3/8" Nylon Nut (124).
4. Route the cable underneath L4 and Pulley L5 mounted in the slot in the bottom of the Front Upright (3) using one 3/8" X 3" Hex Bolt (99), two 3/8" washers (116), two 3/8" ID Bushings (77), and one 3/8" Nylon Nut (124).
5. Connect the steel ball end of the cable to the receptor bracket L6 welded to the Leg Extension Arm (10).

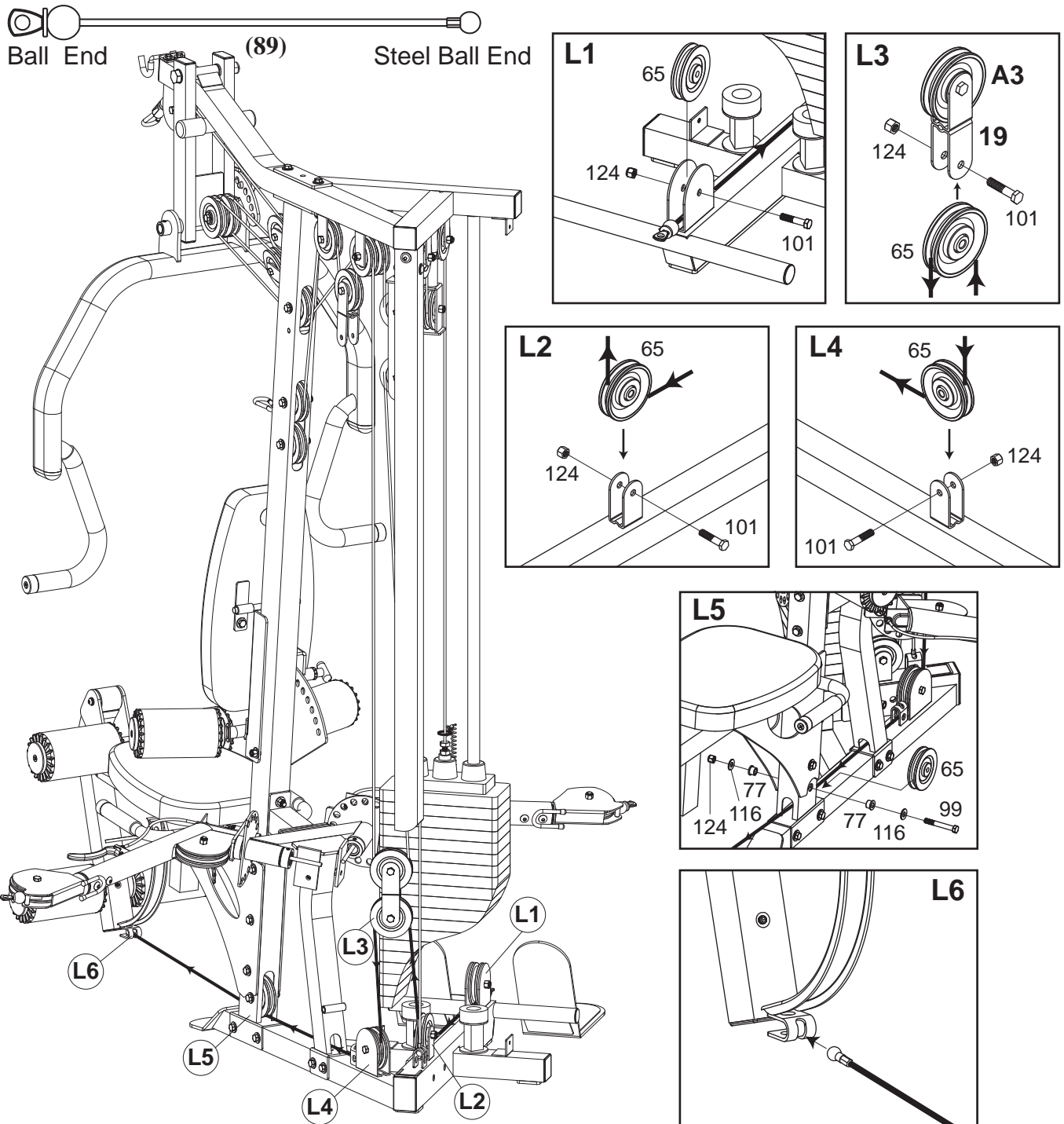

# STEP 9 INSTALL CONNECT CABLE

1. Hook the steel ball end of the Connect Cable (90) to the receptor C1 welded to the Base Frame (1). Route the cable up and over Pulley C2 mounted to the bottom of the Double Pulley Block (19) using one 3/8" X 1-3/4" Hex Bolt (101) and one 3/8" Nylon Nut (124).
2. Screw the threaded end of the cable half way into the threaded receptor on the Adj. Floating Pulley Block (20). The threaded end of the cable is an adjustment point but should always have at least one third of the threads screwed into the Adj. Floating Pulley Block (20).

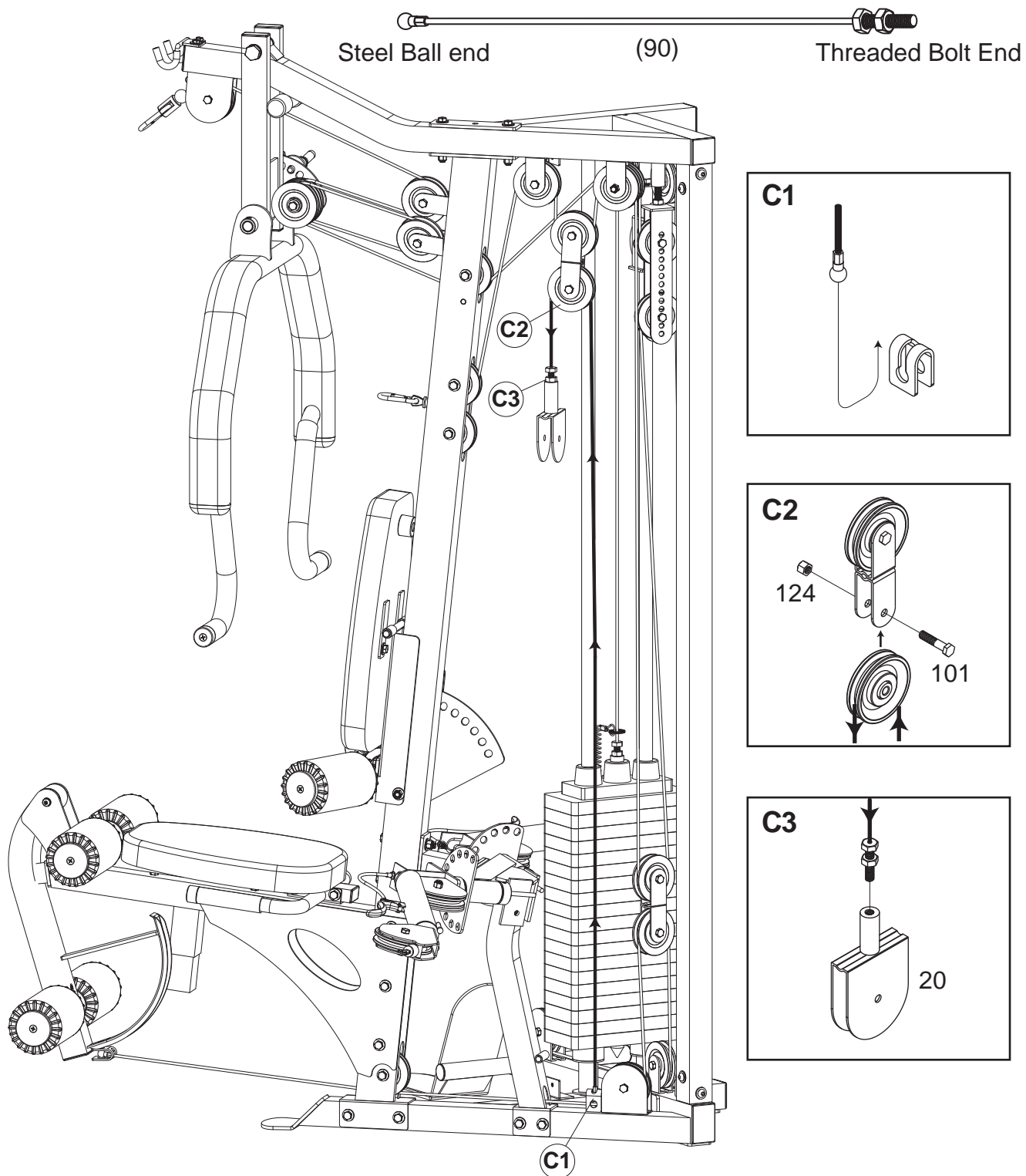



# STEP 10 INSTALL CABLE ARM CABLE

1. The Cable Arm Cable (91) is already run through the Cable Arms (14). Mount Pulleys P3 and P7, along with their Pulley Guide Brackets (32) to the Cable Arm Assembly (11) as shown using one 3/8" X 1-3/4" Hex Bolt (101) and one 3/8" Nylon Nut (124). Route the cable over top of these pulleys. Tighten these nuts, making sure the Pulley Guide Brackets (32) do not rub against the cable.
2. Continue routing, on both sides, down and around Pulleys P4 and P6 mounted to the base of the Cable Arm Assembly (11) using one 3/8" X 4-3/4" Hex Bolt (96), two Pulley Guide Brackets (32), and one 3/8" Nylon Nut (124). As above, tighten this nut, making sure the Pulley Guide Brackets (32) do not rub against the cable.
3. Route the cable up to Pulley P5 mounted inside the Adj. Floating Pulley Block (20) using one 3/8" X 1-3/4" Hex Bolt (101), the Cable Guide Plate (25) and one 3/8" Nylon Nut (124). Loosely hook the Cable Guide Plate (25) to the Connect Cable (90), directly behind.

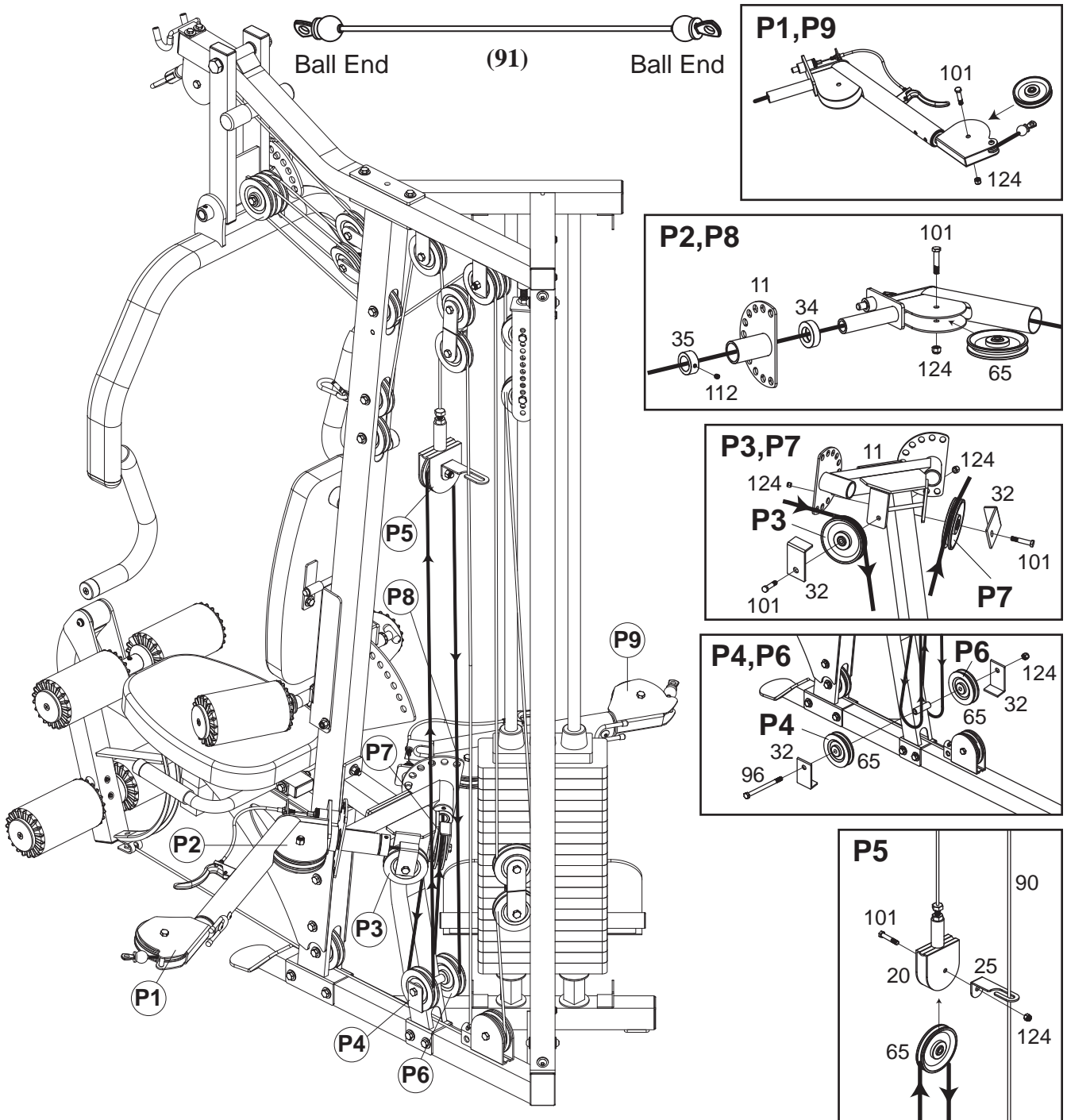

# STEP 11 INSTALL WEIGHT STACK SHROUDS

**ASSEMBLY IS COMPLETE!** Tighten all bolts, starting with main frame bolts on the base, and work way to top.

1. Attach Weight Stack Shroud (26) and Weight Stack Shroud with Number (26A) to the tabs welded on Base Frame (1) and Top Frame (2) as shown, using four 5/16" X 1/2" Round Bolts (104) and four 5/16" Washers (117).

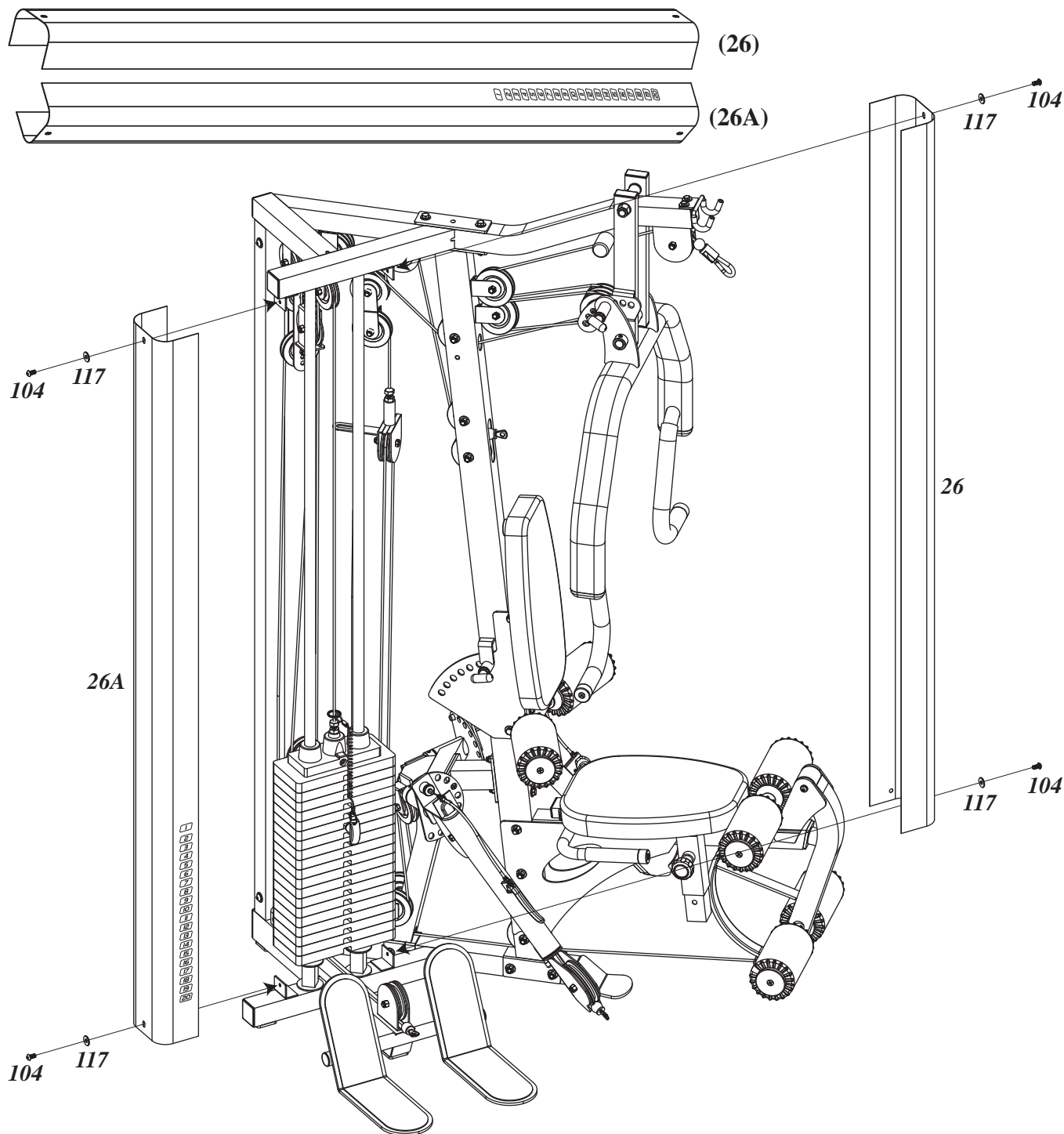

# STEP 12 INSTALL ACCESSORIES

1. Attach Lat Bar (29), Curl Bar (30), Single Handle (43), to the GX Strength Training System.

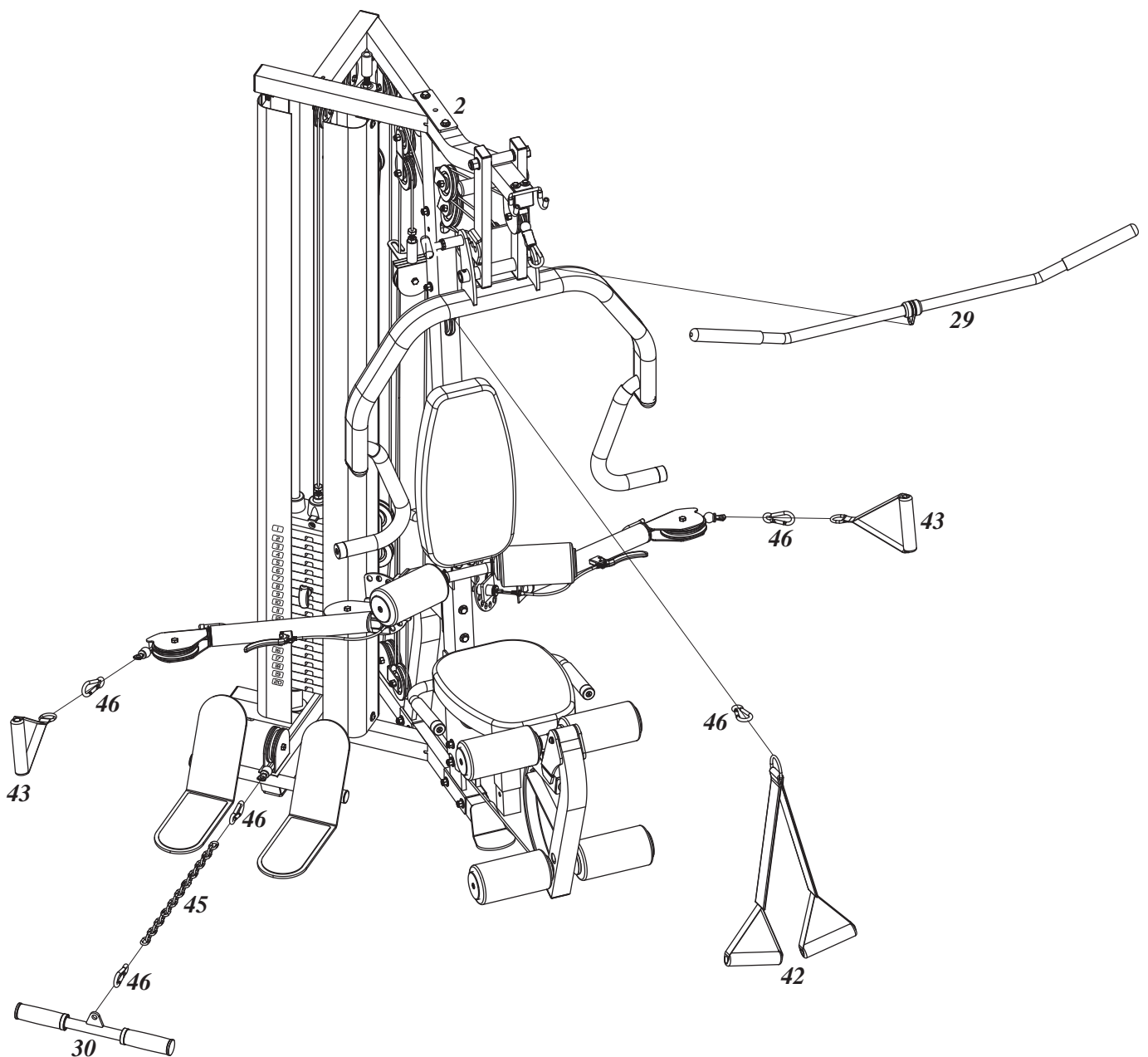

# The Cable Adjustment of GX Strength Training System

- a. The Cables should be tightened to the point just before the Top Plate lifts off the stack. In other words, if the Top Plate is not resting on the stack, you will need to add length, or, if there is slack in the cables, you will need to shorten the cables. There are several adjustment points. If only minor adjustments need to be made, you can adjust the Screw ends on the Top Cable (at the Top Plate), the Low Cable (where it screws into the Pulley Block), or the Bench Press Cable (where it screws into the Pulley Block with Stopper). **These ends of these cables must be screwed in at least 1/3 of their length for safety purposes.** Once you are done with these adjustments, lock them into place using the jam nuts.
- b. Broader adjustments are made at the Adjustable Pulley Block (18). Moving the bottom pulley toward the center decreases length (takes up slack). Conversely, moving the bottom pulley outward gains cable length.
- c. Once the cables have been adjusted to remove all slack, adjust the Adjustable Stoppers in the Top Frame to where they just touch the Adjustable Pulley Block (18). The Adjustable Stoppers welded on top frame aid in the function of the gym by eliminating the need to engage all cables in any given exercise routine.

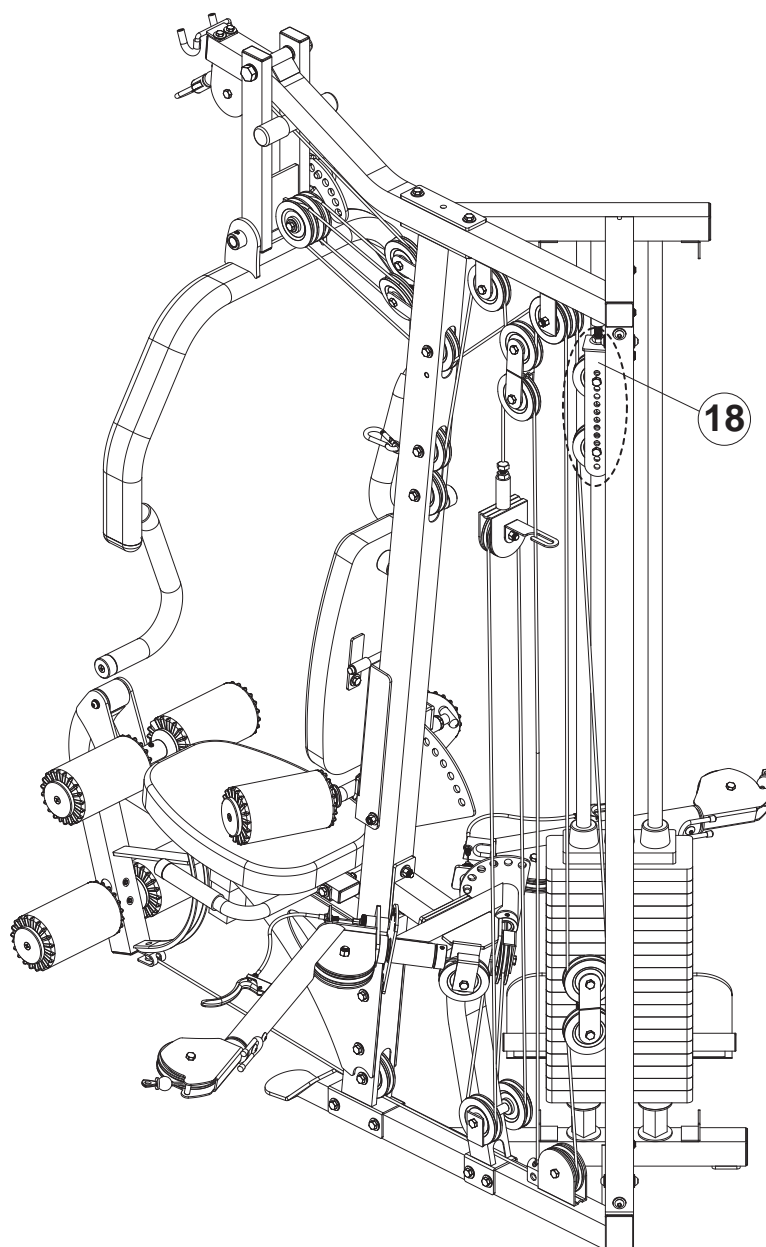

**Assembly is complete! Please take the following steps before using the gym:**

1. Make certain all bolts are tightened securely.
2. Make certain all cables are seated into all pulley grooves. A cable rubbing against steel will peel the nylon coating, voiding warranty and resulting in a need for replacement.
3. Pre-stretch the cables. Put the Weight Selector Pin (94) in the bottom hole on the weight stack. Pull on the cables with great force, helping remove any kinks and providing any initial cable stretch.
4. Be aware the cables can loosen and slightly stretch upon initial use.
5. The cables should be adjusted as tight as possible, but no so tight as to lift the Top Plate (39) above the weight stack. Be certain to secure the jam nuts after adjustments are made.
6. For better performance, apply a household lubricant (such as silicone) to any adjustable areas and to the **Guide Rods (5)**.
7. Enjoy many years of a Fit Lifestyle.

**Thank you for purchasing the Bodycraft GX Home Gym. If you have any questions, please call your local BodyCraft dealer, call our customer service department at 800-990-5556 or at <http://www.bodycraft.com>.**

# 6880 GX Foot Plate

Please remove and discard the two 3/8" X 3" Hex Bolts (99) that attach the Cable Arm (14) assembly Bottom Frame (11) to the Base Frame (1). Attach the Stabilizing Plate (20A) at this location using two 3/8" X 3-1/4" Hex Bolts (98A) and the original 3/8" Washers (116), and original 3/8" Nylon Nuts (124). You may need to loosen the bolts at the top of the Cable Arm Assembly Bottom Frame to help the holes line up.

**Very important!  
The Stabilizing  
Plate helps  
prevent tipping!**

Tighten all bolts.

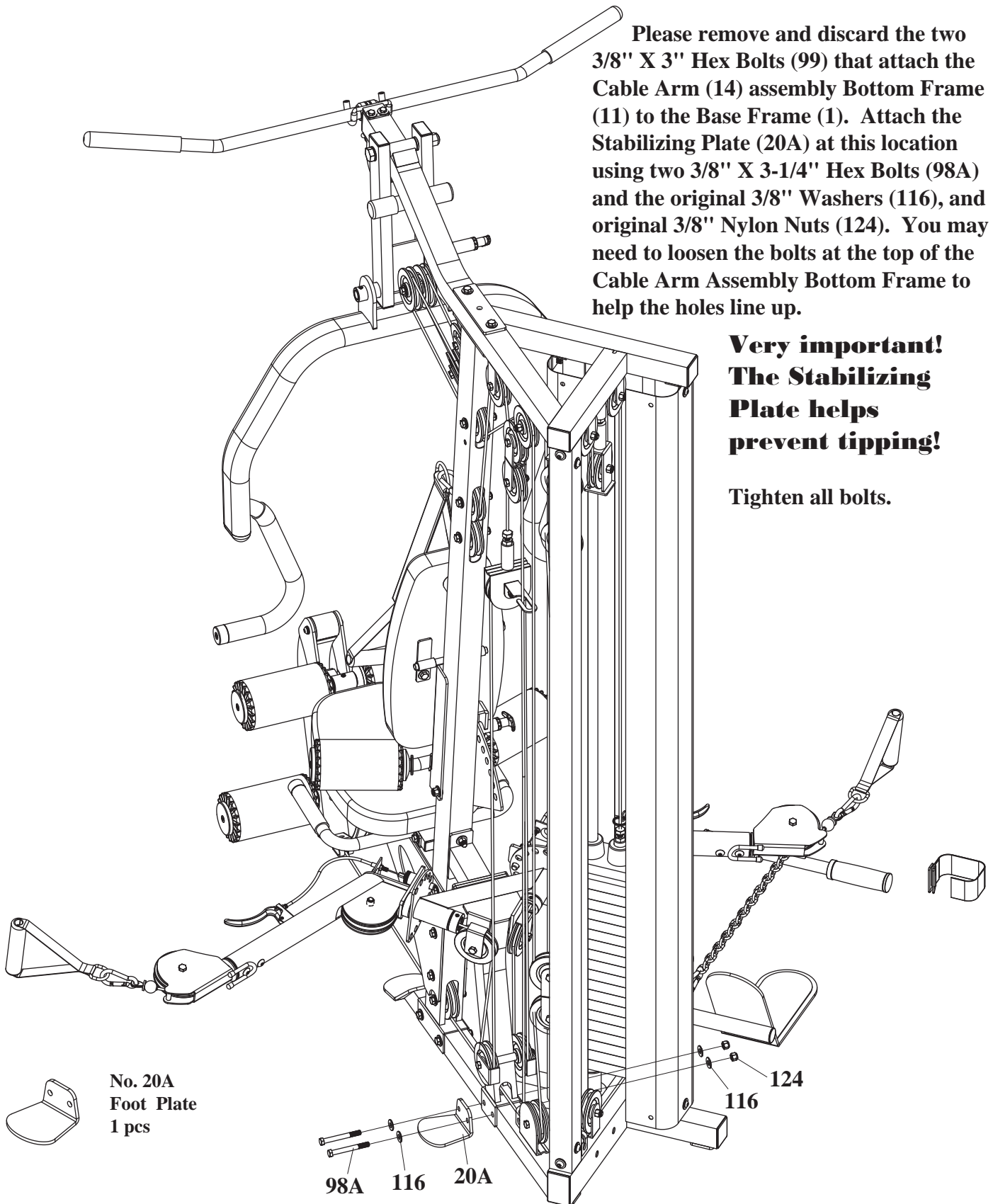

No. 20A  
Foot Plate  
1 pcs

No. 98A  
3/8" X 3-1/4" Hex Bolt  
2 pcs