

BODYWORX

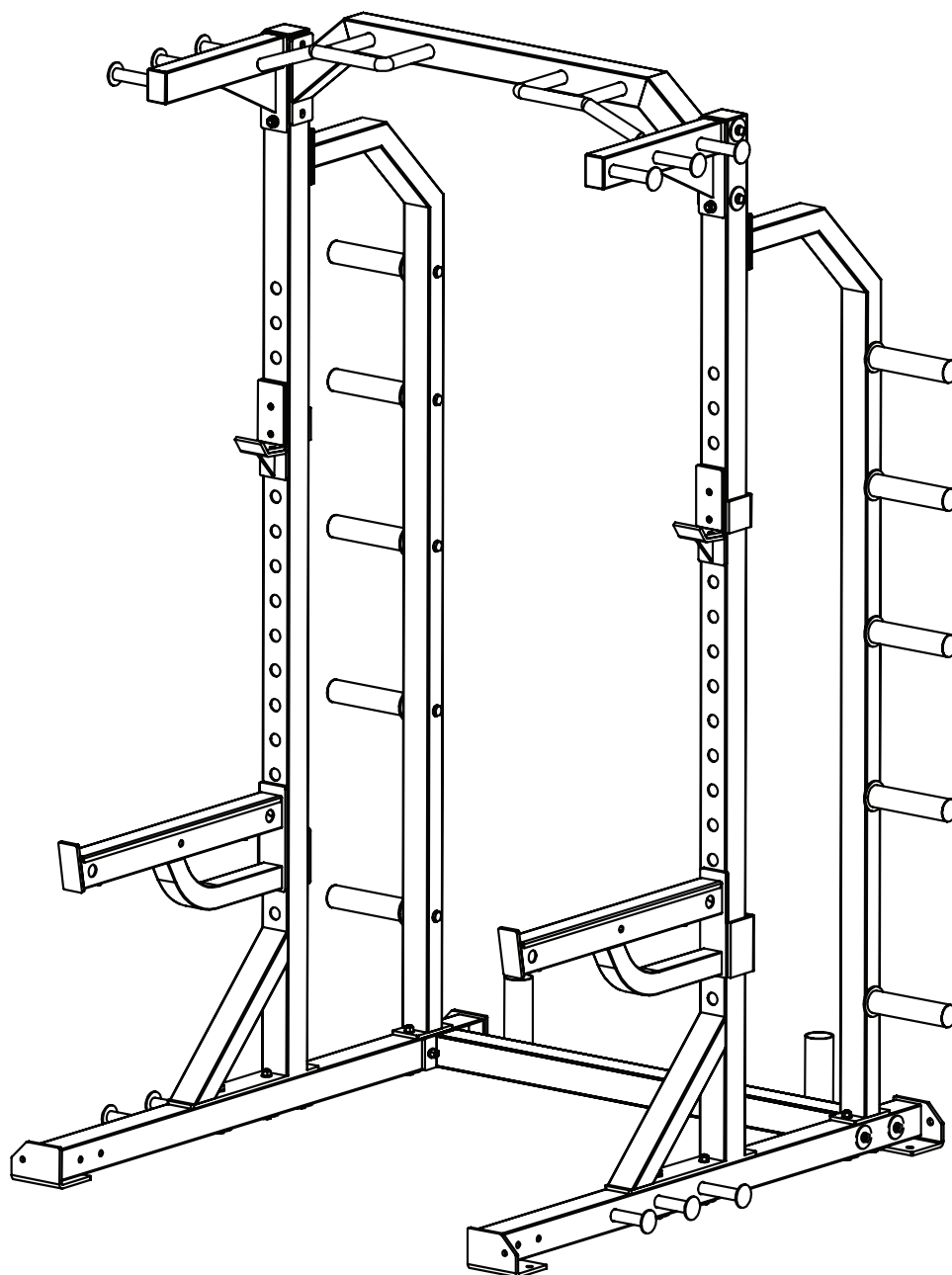

HEAVY DUTY HALF RACK

Model No:
L870HR



Retain this owner's manual for future reference
Read and follow all instructions in this owner's manual

Version A

Assembly Instructions

Contents

Contents	1
Before You Begin	2
Assembly Steps	3-5
Parts & Hardware List	6

Assembly Instructions

Before Your Begin

This exercise equipment is built for optimum safety. Be sure to read the entire manual before you assemble or operate your equipment. Please note the following safety precautions:

1. Keep children and pets away from the equipment at all times. Do not leave children unattended in the same room with the equipment.
2. Only one person at a time should use the equipment.
3. If the user experiences dizziness, nausea, chest pain, or any other abnormal symptoms STOP the workout at once.
CONSULT A PHYSICIAN IMMEDIATELY.
4. Position the equipment on a clear, level surface. DO NOT use the bench near water or outdoors.
5. Keep hands away from all moving parts.
6. Always wear appropriate workout clothing when exercising. DO NOT wear robes or other clothing that could become caught in the equipment.
7. Use the equipment only for its intended use as described in this manual. DO NOT use attachments not recommended by the manufacturer.
8. Before using the equipment, always do stretching exercises to properly warm up.
9. Never operate the equipment if the equipment is not functioning properly.

Tools Required

Tools Required : Allen Wrench Set / Socket Wrench Set
Adjustable Wrench / Crescent Wrench
Rubber Mallet / Tape Measure

ASSEMBLY REQUIRES AT LEAST THREE PERSONS

Note:

1. Only hand tighten all nuts and bolts until whole equipment assembled.
2. Descriptions of pieces as LEFT and RIGHT are from the point of view of standing behind the equipment facing towards the front.

Assembly Instructions

STEP 1

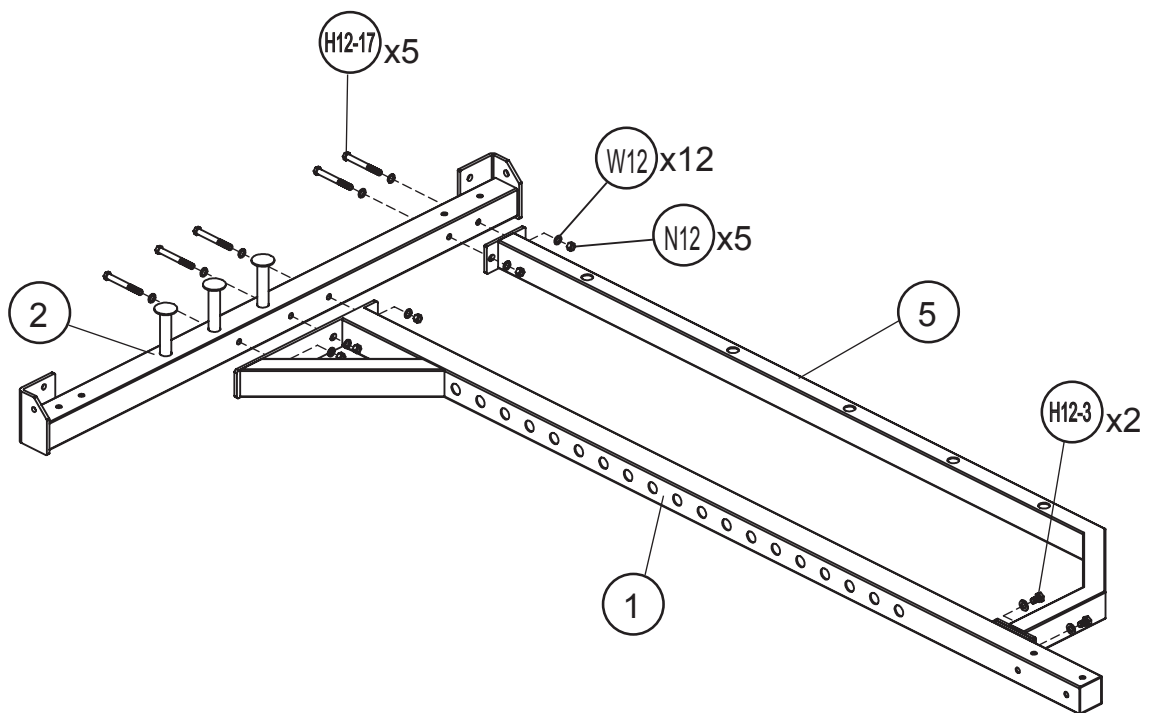

Note:

1. Lie Down the Right Upright and the Right Base, then Assemble the Both as Above Illustration.
2. Assemble the Left Part with the Same Way.

Assembly Instructions

STEP 2

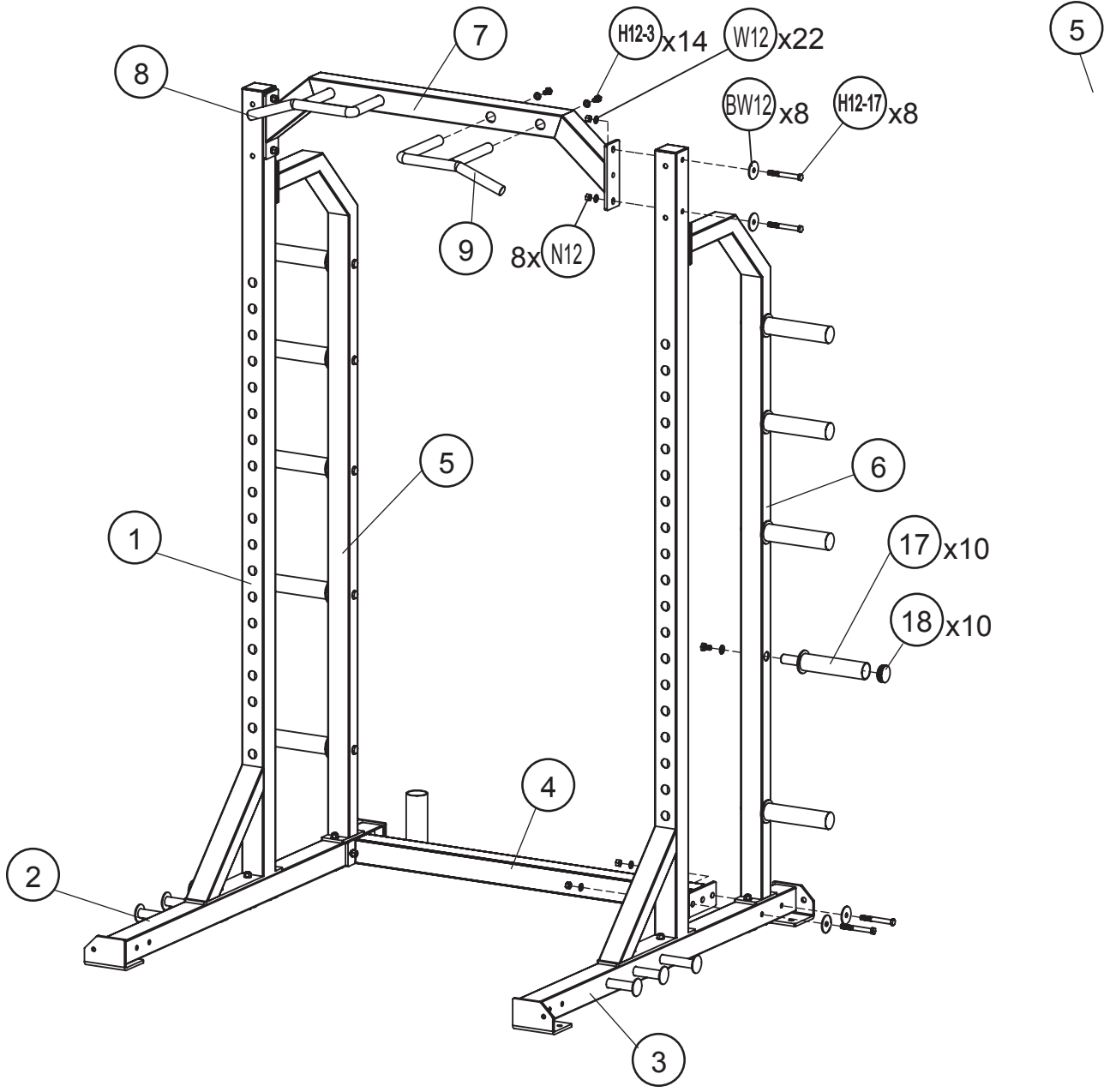

Assembly Instructions

STEP 3

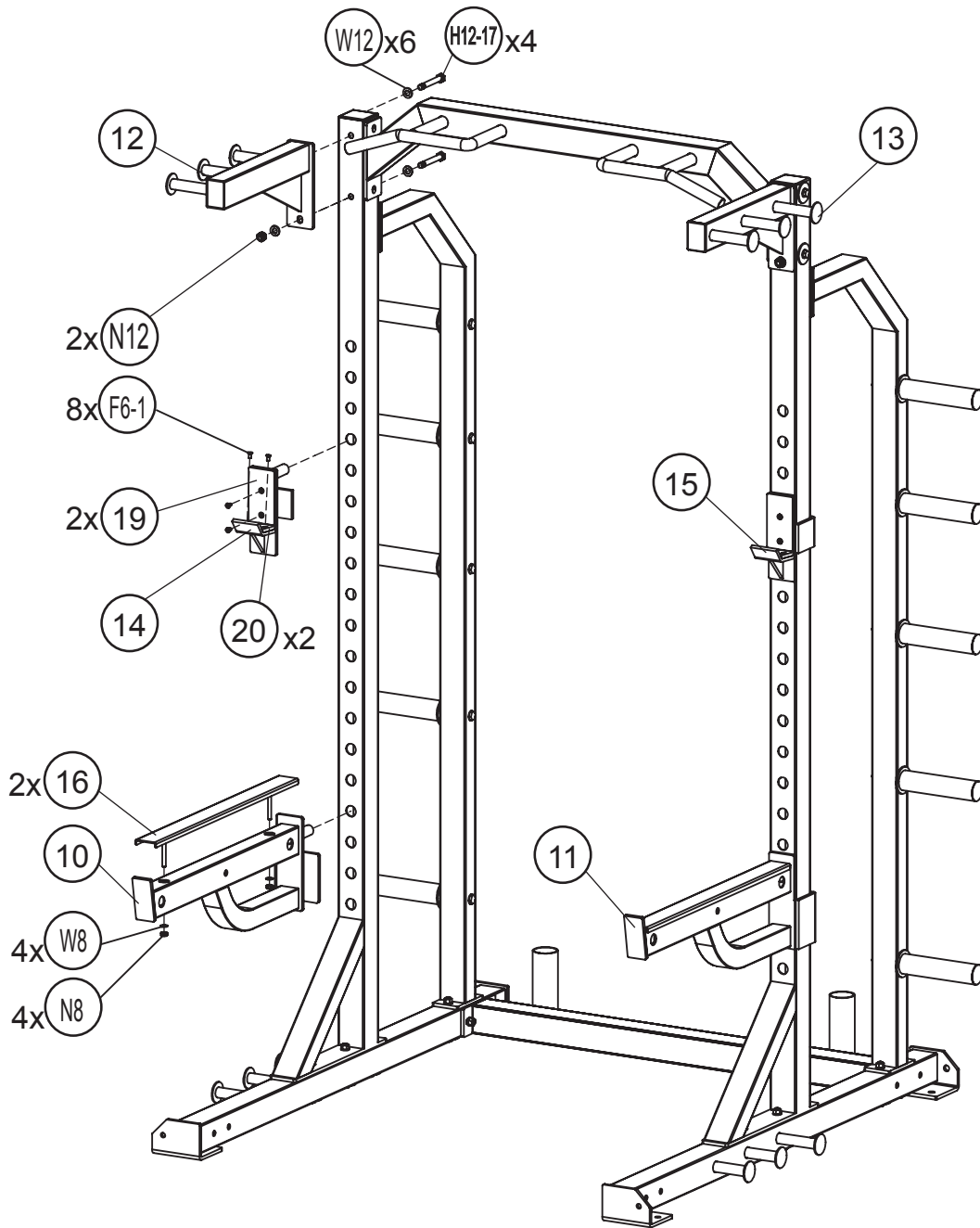

Assembly Instructions

Parts & Hardware List

Part#	Discription	Qty	Remark
1	Upright Frame	2	
2	Right Base	1	
3	Left Base	1	
4	Bottom Cross Frame	1	
5	Right Rear Support	1	
6	Left Rear Support	1	
7	Top Cross Frame	1	
8	Right Handle	1	
9	Left Handle	1	
10	Right Spotting Arm	1	
11	Left Spotting Arm	1	
12	Right Band Hook	1	
13	Left Band Hook	1	
14	Right J-Hook	1	
15	Left J-Hook	1	
16	Spotting Arm Cover	2	Pre-assembled
17	Plate Storage Holder	10	
18	Dia 48mm Inner Cap	2	Pre-assembled
19	Big Rubber Pad	2	Pre-assembled
20	Small Rubber Pad	2	Pre-assembled
F6-1	M6x10mm Flat Head Bolt	8	Pre-assembled
H12-3	M12x25 mm Hex Head Bolt	18	
H112-17	M12x95 mm Hex Head Bolt	22	
W8	M8 Washer	4	Pre-assembled
BW12	M12 Big Washer	8	
W12	M12 Washer	52	
N8	M8 Nut	4	Pre-assembled
N12	M12 Nut	20	



Model No: L870HR

To register your warranty, please go to
www.gpisports.com.au

Distributed Exclusively by :
GPI Sports & Fitness
275 Wellington Road
Mulgrave, VIC, 3170
Australia.