

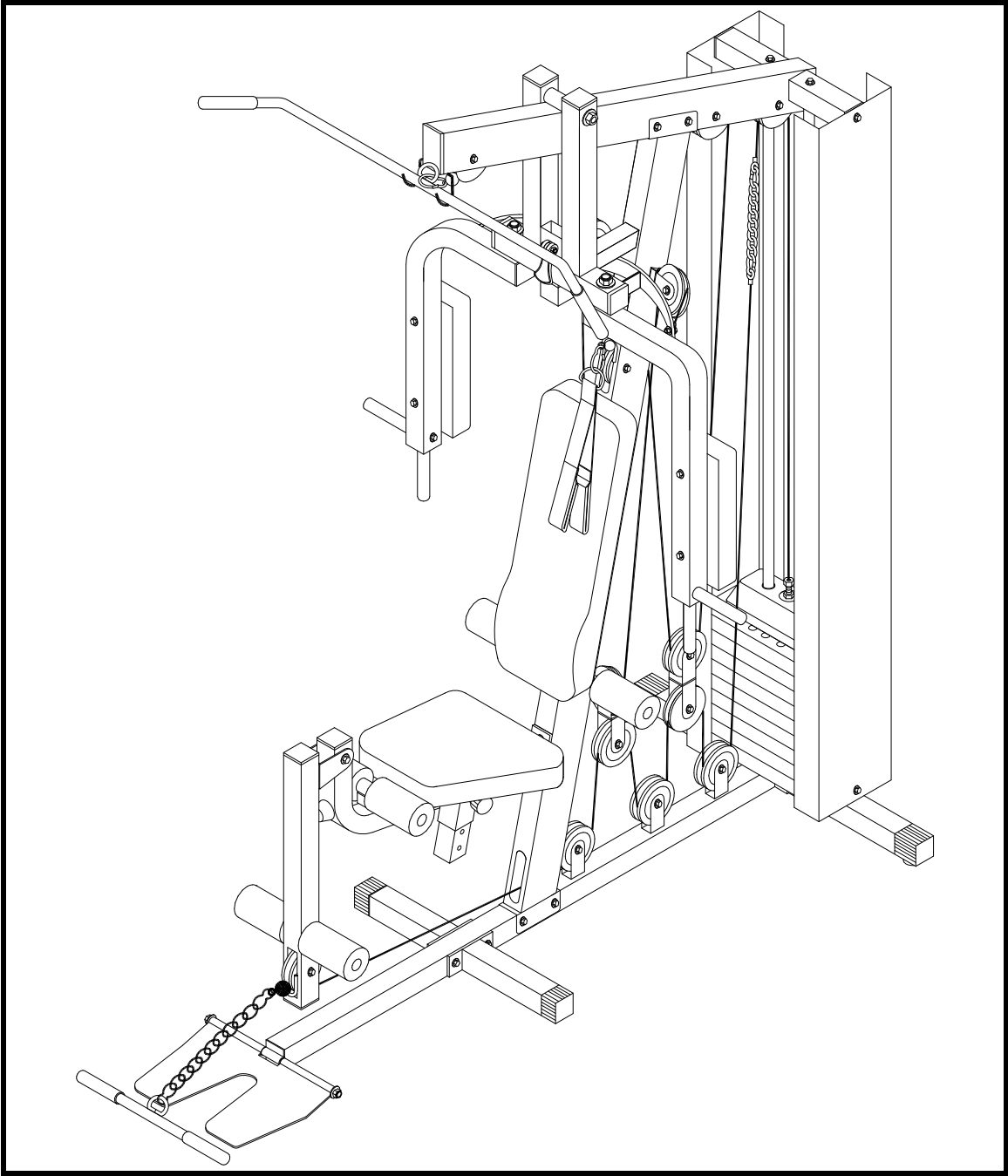

HOME GYM

L8000HG



OWNER'S MANUAL



Warranty Registration Form

Congratulations on purchasing your product, we at GPI believe that our product range is of the highest quality and represents great value for money.

We back our product range up with our industry leading warranty.

Please see below for the step by step instructions on how to register your product warranty online.



Step 1

Visit our Website

Go to the GPI Sports website: www.gpisports.com.au/warranty



Step 2

Enter Purchase Information

Enter all purchase information including the serial number and proof of purchase which can be uploaded from this page













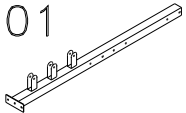
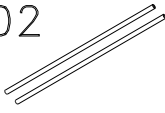
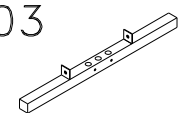

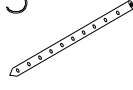
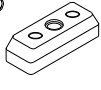
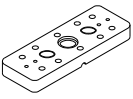

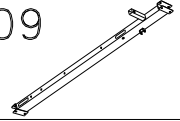
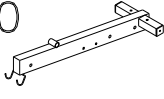
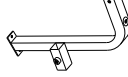
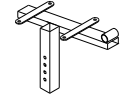

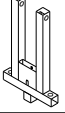
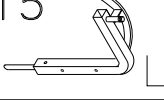
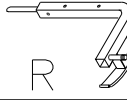





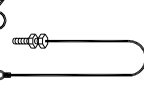
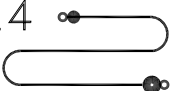
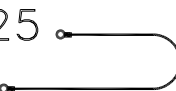
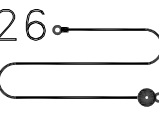



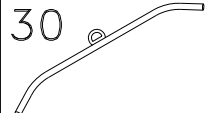
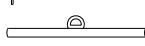















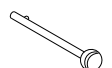

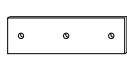

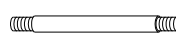







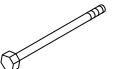









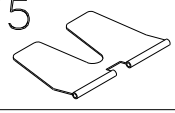
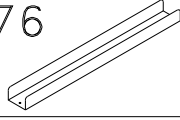

Step 3

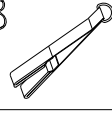
Call Our Toll Free Number

If a warranty service request is required on your product please call the toll free number - **1800 005 770**

BODYCRAFT

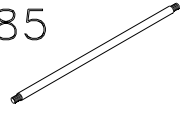
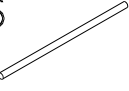

| | | | | | |
|---|--|--|--|---|--|
| 01  | 02  | 03  | 04  | 05  | 06  |
| 07  | 08  | 09  | 10  | 11  | 12  |
| 13  | 14  | 15  | 16  | 17  | 18  |
| 19  | 20  | 21  | 22  | 23  | 24  |
| 25  | 26  | 27  | 28  | 29  | 30  |
| 31  | 32  | 33  | 34  | 35  | 36  |
| 37  | 38  | 39  | 40  | 41  | 42  |
| 43  | 44  | 45  | 46  ø10.5x56L | 47  ø48xø13x3t | 48  |
| 49  | 50  | 51  | 52  | 53  | 54  M12X75mm |
| 55  M10X125MM | 56  M10X75mm | 57  M10X70mm | 58  M10X45mm | 59  M10X30mm | 60  M10X25mm |
| 61  M8X115MM | 62  M8X65MM | 64  M8X15mm | 65  M10 | 66  M16 | 67  M12 |
| 68  M10 | 69  M8 | 70  M16 | 71  M12 | 72  M10 | 73  M8 |
| 74  | 75  | 76  | 77  | 78  | 79  |
| 80  | 81  M6X30mm | 82  M6 | 83  | 84  | 85  |
| 86  | 87  | | | | |

PART LIST

| PART NO: | DESCRIPTION | Q'TY |
|----------|----------------------------|------|
| 1. | MAIN BASE | 1 |
| 2. | GUIDE ROD | 2 |
| 3. | LEFT BASE | 1 |
| 4. | RIGHT BASE | 2 |
| 5. | SELECTOR SHAFT | 1 |
| 6. | TOP PLATE | 1 |
| 7. | WEIGHT STACK | 10 |
| 8. | RUBBER DOUNT | 2 |
| 9. | VERTICAL BEAM | 1 |
| 10. | TOP CROSS BEAM | 1 |
| 11. | SEAT SUPPORT | 1 |
| 12. | SEAT ASSEMBLY UNIT | 1 |
| 13. | LEG EXTENSION/ARM CURL BAR | 1 |
| 14. | PRESS BAR | 1 |
| 15. | LEFT PEC DECK ARM | 1 |
| 16. | RIGHT PEC DECK ARM | 1 |
| 17. | PRESS PIN | 1 |
| 18. | SEAT | 1 |
| 19. | BACK SEAT | 1 |
| 20. | PULLEY BLOCK | 2 |
| 21. | FLOATING PULLEY BLOCK(A) | 1 |
| 22. | FLOATING PULLEY BLOCK(B) | 1 |
| 23. | WEIGHT STACK CABLE 1340MM | 1 |
| 24. | LAT BAR CABLE 3480MM | 1 |
| 25. | PEC DECK CABLE 2750MM | 1 |
| 26. | CURL BAR CABLE 3350MM | 1 |
| 27. | CHAIN | 3 |
| 28. | PEC DECK PAD | 2 |
| 29. | LEG EXTENSION/CURL PAD | 6 |
| 30. | LAT BAR | 1 |
| 31. | CURL BAR | 1 |
| 32. | PAD HOLDER | 2 |
| 33. | HANDLE PIPE | 2 |
| 34. | PULLEY | 14 |
| 35. | HAND GRIP | 8 |
| 36. | CHAIN HOOK | 7 |
| 37. | RUBBER BUMPER | 2 |
| 38. | PLASTIC BUSHING | 10 |
| 39. | RUBBER END CAP | 2 |
| 40. | RUBBER CAP | 3 |
| 41. | 50*50MM SQUARE END CAP | 8 |
| 42. | 38*38 MM SQUARE END CAP | 2 |
| 43. | 25*50MM SQUARE END CAP | 2 |

PART LIST

| PART NO: | DESCRIPTION | Q'TY |
|----------|---------------------------------------|------|
| 44. | 25MM ROUND END CAP | 6 |
| 45. | 25MM ROUND BUSHING | 1 |
| 46. | QUICK PIN | 1 |
| 47. | OD48MM*ID13MM WASHER | 1 |
| 48. | PIN FOR WEIGHT SATCK | 1 |
| 49. | ADJUSTABLE POP PIN | 1 |
| 50. | STEEL PLATE (LONG) | 1 |
| 51. | STEEL PLATE (SHORT) | 1 |
| 52. | OIL BUSHING | 6 |
| 53. | PRESS BAR SHAFT | 1 |
| 54. | M12*75MM HEX BOLT | 1 |
| 55. | M10*125MM HEX BOLT | 2 |
| 56. | M10*75MM HEX BOLT | 4 |
| 57. | M10*70MM HEX BOLT | 9 |
| 58. | M10*45MM HEX BOLT | 9 |
| 59. | M10*30MM HEX BOLT | 2 |
| 60. | M10*25MM HEX BOLT | 6 |
| 61. | M8*115MM HEX BOLT | 2 |
| 62. | M8*65MM HEX BOLT | 7 |
| 64. | M8*15MM HEX BOLT | 8 |
| 65. | M10 NUT | 2 |
| 66. | M16 NYLON NUT | 4 |
| 67. | M12 NYLON NUT | 1 |
| 68. | M10 NYLON NUT | 28 |
| 69. | M8 NYLON NUT | 3 |
| 70. | M16 WASHER | 4 |
| 71. | M12 WASHER | 2 |
| 72. | M10 WASHER | 60 |
| 73. | M8 WASHER | 20 |
| 74. | SQUARE CAP ψ 26x \square 38 MM | 2 |
| 75. | PEDAL | 1 |
| 76. | WEIGHT COVER | 2 |
| 77. | ANKLE STRAPE | 1 |
| 78. | TRICEPS STRAPE | 1 |
| 79. | FASTENING | 1 |
| 80. | SPRING | 1 |
| 81. | M6*30MM HEX BOLT | 1 |
| 82. | M6 NYLON NUT | 1 |
| 83. | 50*100MM SQUARE END CAP | 2 |
| 84. | SPRING WASHER | 2 |
| 85. | PRESS BAR SHAFT 10MM | 1 |
| 86. | PAD HOLDER (LONG) | 1 |
| 87. | RUBBER BUMPER(SHORT) | 1 |

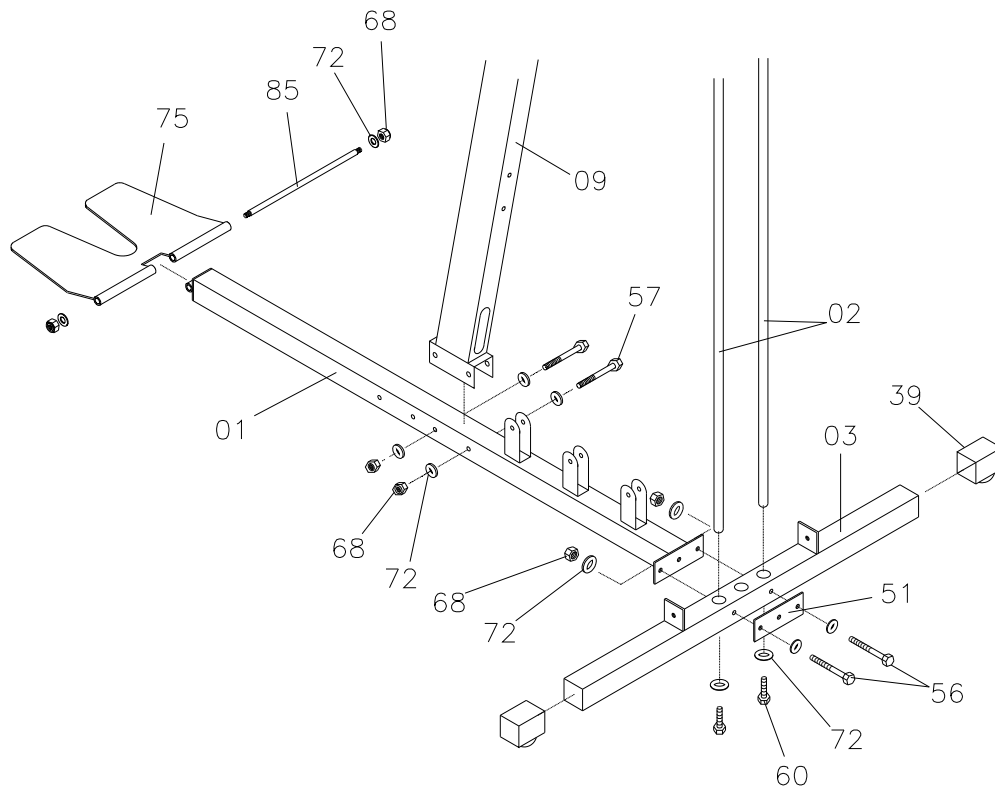

STEP 01

1. PLACE RUBBER END CAP (39) ONTO BOTH ENDS OF LEFT BASE (03)
2. INSERT GUIDE RODS (02) TO LEFT BASE (03) WITH M10*25MM BOLT (60), M10 WASHER (72) AS SHOWN.
3. ATTACH MAIN BASE (01) TO LEFT BASE (03) WITH M10*75MM BOLT (56), M10 WASHER (72) AND M10 NYLON NUT (68) AS SHOWN.
FASTEN ALL BOLTS BY USING TOOL.
4. ATTACH VERTICLE BEAM (09) TO MAIN BASE (01) WITH M10*70MM BOLT (57), M10 WASHER (72) AND M10 NYLON NUT (68) AS SHOWN.
5. ATTACH PEDAL (75) ONTO MAIN BASE (01) WITH PRESS BAR SHAFT 10MM (85), M10 WASHER (72) AND M10 NYLON NUT (68) AS SHOWN.

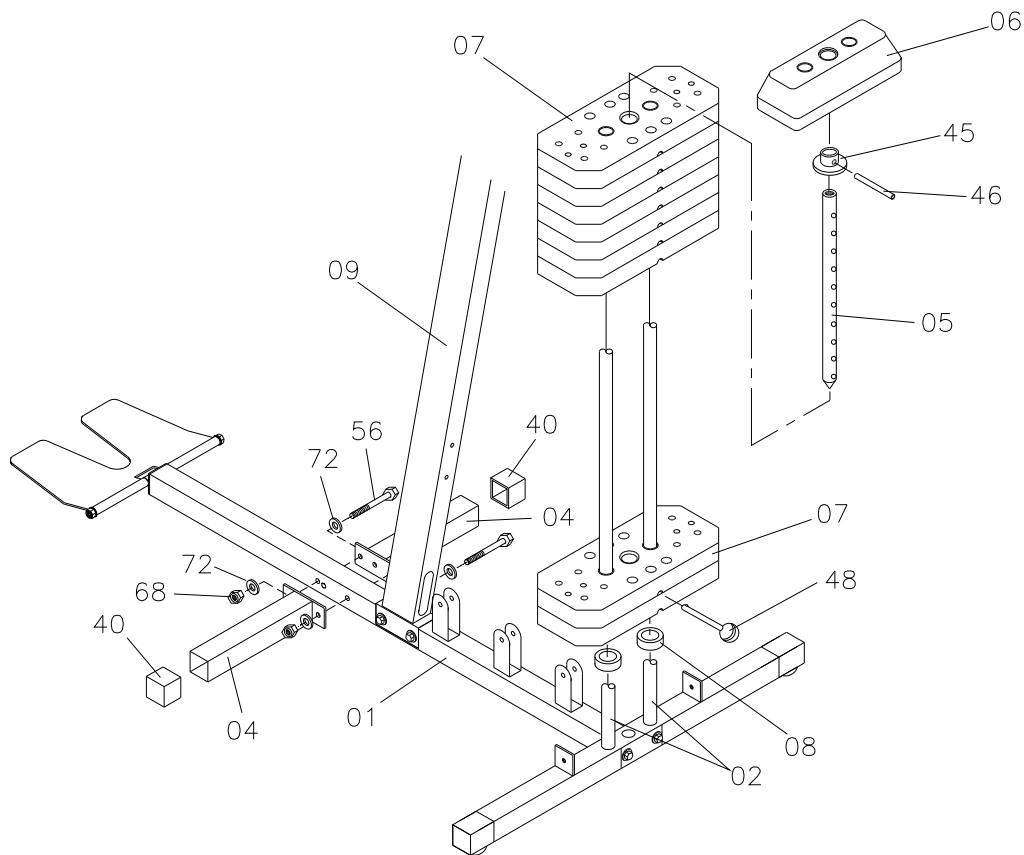

STEP 02

1. ATTACH THE RUBBER DOUNT (08) ONTO THE GUIDE ROD (02).
2. SLIDE THE WEIGHT PLATE (07) AND TOP PLATE (06) OVER GUIDE ROD (02).
GROOVED SIDE OF WEIGHT PLATES SHOULD FACE DOWN
3. INSTALL 25MM ROUND BUSHING (45) INTO THE SELECTOR SHAFT (05). WITH PIN (46) THEN ATTACH THE SELECTOR SHAFT (05) INTO THE TOP PLATE (06) AS SHOWN.
4. PLACE 50MM SQUARE CAP (41) ONTO FRONT BASE (01).
5. PLACE RUBBER CAP (40) ONTO BOTH ENDS OF RIGHT BASE (04).
6. ATTACH RIGHT BASE (04) TO MAIN BASE (01) WITH M10*75MM BOLT (56), M10 WASHER (72) AND M10 NYLON NUT (68) AS SHOWN.

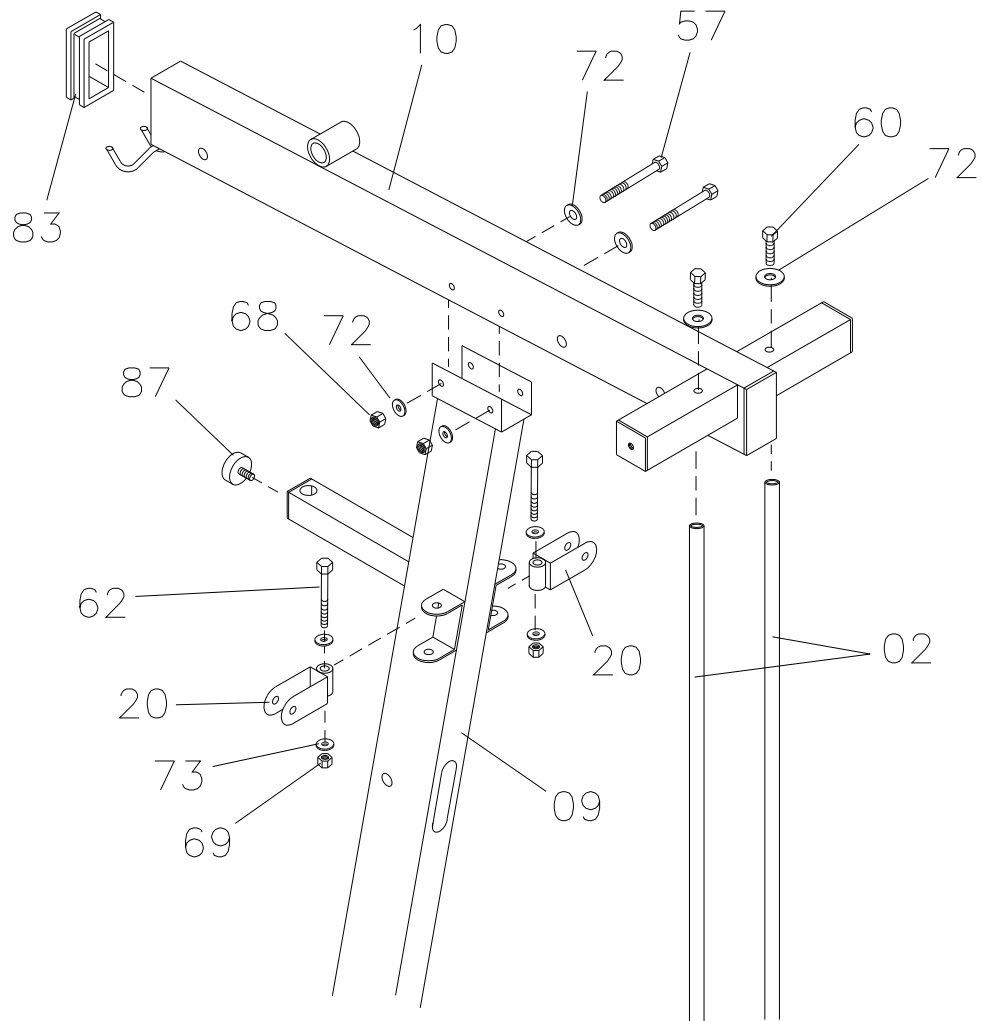

STEP 03

1. PLACE 50*100MM SQUARE CAP (83) ONTO TOP CROSS BEAM (10).
2. ATTACH TOP CROSS BEAM (10) ONTO THE VERTICLE BEAM (09) WITH M10*70MM BOLT (57), M10 WASHER (72) AND M10 NYLON NUT (68) AND CONNECT THE GUIDE RODS (02) TO THE TOP CROSS BEAM (10) AS SHOWN.
3. ATTACH RUBBER BUMPER (37) TO THE VERTICLE BEAM (09).
4. ATTACH PULLEY BLOCK (20) TO THE VERTICLE BEAM (09), USE M8*60MM BOLT (62) WITH M8 WASHER (73) AND M8 NUTS (69).
5. PLACE 38MM SQUARE CAP (42) ONTO VERTICLE BEAM (09).

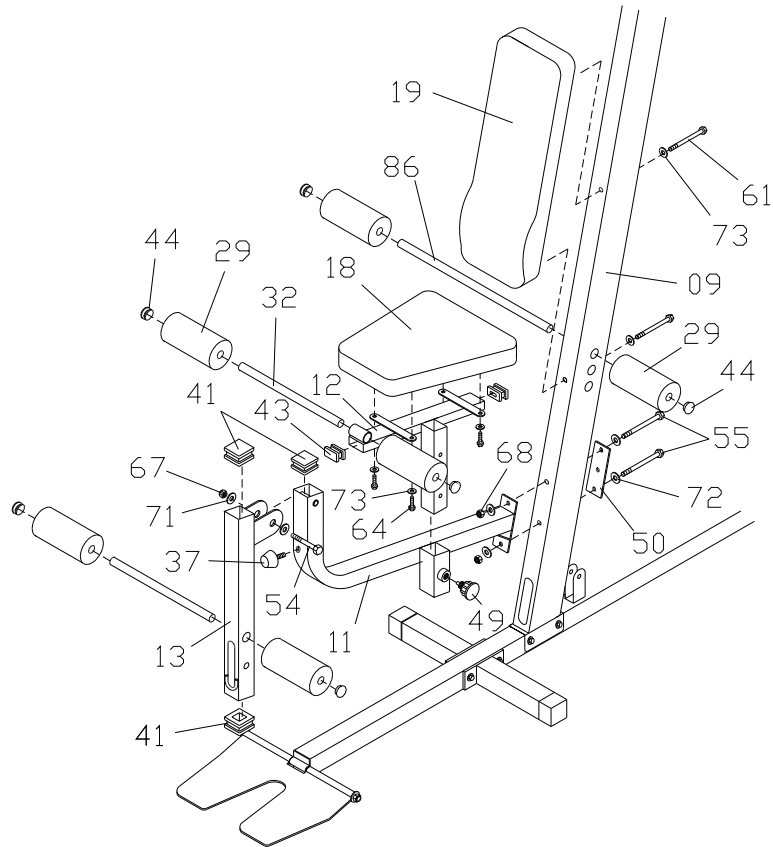

STEP 04

1. PLACE 50MM SQUARE CAP (41) ONTO BOTH ENDS OF LEG EXTENSION /ARM CURL BAR (13).
2. ATTACH SEAT SUPPORT (11) TO VERTICLE BEAM (09), WITH STEEL PLATE (50) M10*125MM BOLT (55), M10 WASHERS (72), AND M10 NYLON NUT (68).
3. ATTACH SEAT ASSEMBLY UNIT (12) TO SEAT SUPPORT (11) AS SHOWN.
4. ATTACH LEG EXTENSION /ARM CURL BAR (13) TO SEAT SUPPORT (11).
5. ATTACH BACK SEAT (19) TO VERTICLE BEAM (09) AS SHOWN.
6. ATTACH SEAT (18) TO SEAT ASSEMBLY UNIT (12) AS SHOWN.
7. SLIDE PAD HOLDERS (32) INTO THE HOLE PROVIDED.
8. SLIDE PAD HOLDER (LONG) (86) INTO THE HOLE OF VERTICLE BEAM (09).
9. SLIDE LEG EXTENSION/CURL PADS (29) ONTO PAD HOLDERS (32) AND PAD HOLDER (LONG) (86).
10. PLACE 25MM ROUND CAP (44) ONTO PAD HOLDERS (32) AND (86).

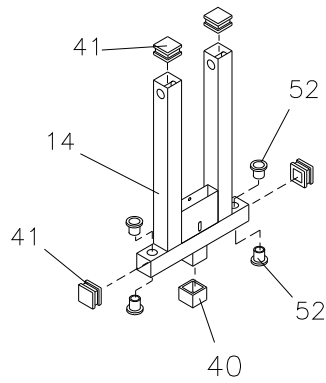

STEP 05

1. PLACE 50MM SQUARE CAP (41) INTO BOTH ENDS OF PRESS BAR (14).
2. INSTALL OIL BUSHING (52) INTO THE PRESS BAR (14).
3. RUBBER CAP (40) TO PRESS BAR (14) AS SHOWN.

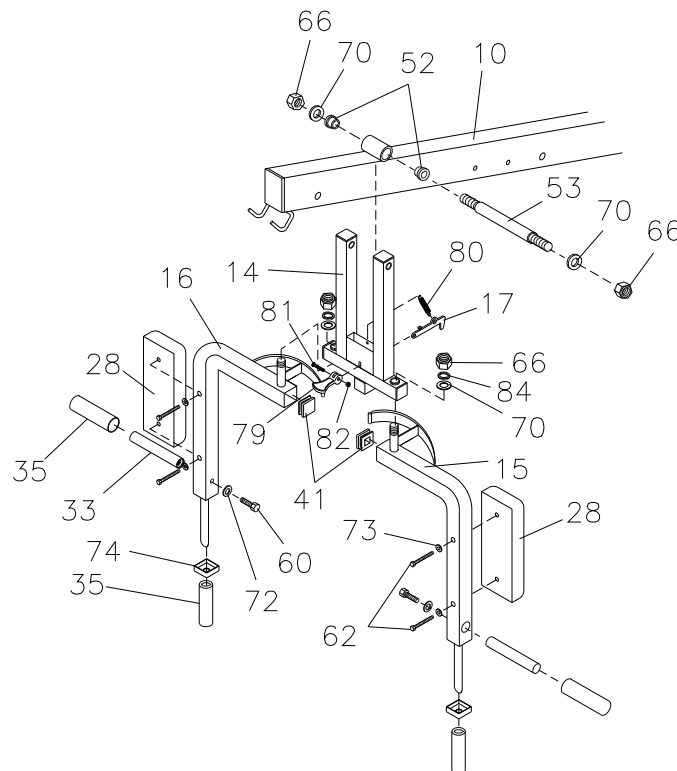

STEP 06

1. ATTACH PRESS BAR (14) TO TOP CROSS BEAM (10) WITH PRESS BAR SHAFT (53) AND OIL BUSHING (52) M16 WASHER (70) M16 NYLON NUT (66) AS SHOWN.
2. ATTACH PEC DEC PAD (28) ONTO PEC DEC ARM (15&16) WITH M8*65MM BOLT (62) M8 WASHER (73) AS SHOWN.
3. ATTACH HANDLE PIPE (33) AND HAND GRIP (35) TO PEC DEC ARM (15&16) WITH M10 BOLT (60), M10 WASHER (72) AS SHOWN.
4. INSTALL PEC DEC ARM (15&16) TO PRESS BAR (14) WITH M16 WASHER (70) AND M16 NYLON NUT (66) AS SHOWN.
5. PLACE PRESS PIN (17) INTO PRESS BAR (14) USE FASTENING (79) WITH M6*30MM BOLT (81) M6 NYLON NUT (82) AND SPRING (80) AS SHOWN.

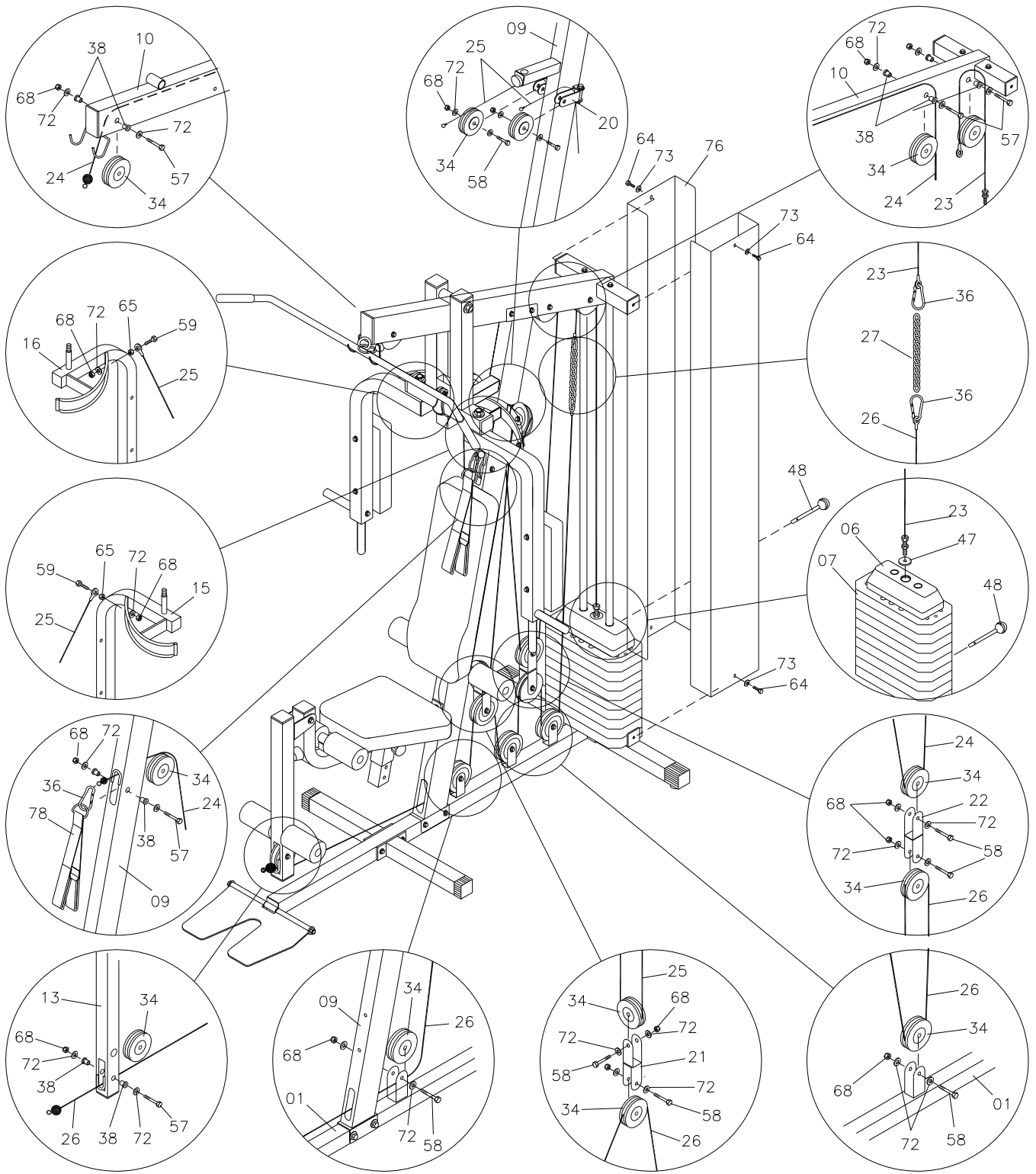

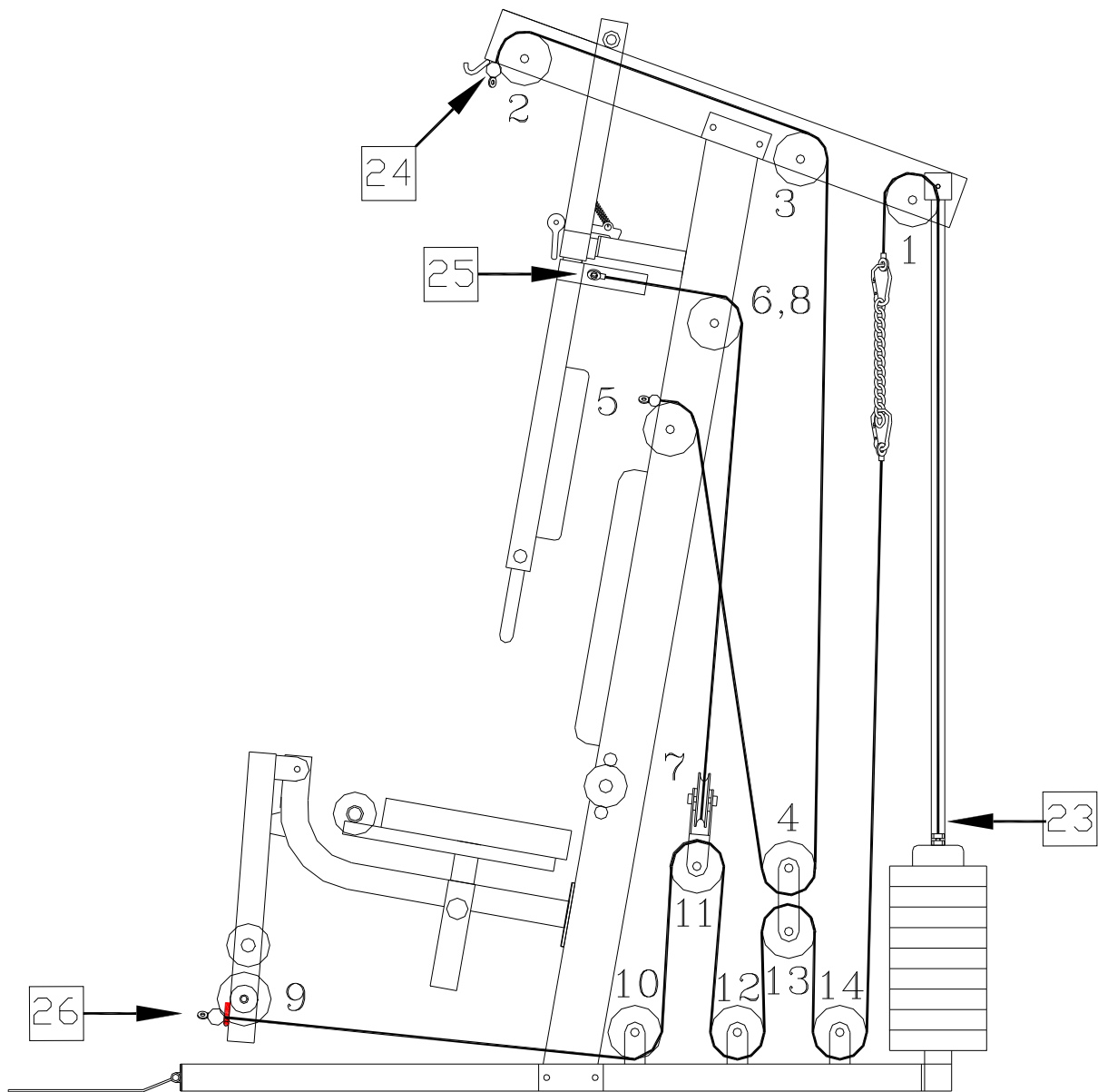

Make certain all cables are seated into all pulley grooves. A cable rubbing against steel will peel the nylon coating, voiding warranty and resulting in a need for replacement.

Pre-stretch the cables. Put the Weight Selector Pin in the bottom hole on the weight stack. Pull on the cables with force, helping remove any kinks and providing any initial cable stretch.

Be aware the cables can loosen and slightly stretch upon initial use. The cables should be adjusted as tight as possible,

For better performance, apply a household lubricant (such as silicone) to any adjustable areas and to the Guide Rods

---CABLE ASSEMBLY---

1. START WITH WEIGHT STACK CABLE 1340MM (23)

START ATTACH CABLE (23) WITH M12 BOLT AND WASHER (47) TO WEIGHT STACK FASTEN THE OTHER END UP AND OVER AROUND PULLEY NO.1, DOWN WITH CHAIN HOOK (36) AND CHAIN (27) AS SHOWN.

2. START WITH THE TOP LAT BAR CABLE 3480MM (24)

START BY THREADING THE END OF THE CABLE THE SMALL BALL OVER GET INTO PULLEY NO.2, INTO OVER PULLEY NO.3, DOWN AND AROUND PULLEY NO.4 IN FLOATING PULLEY LOCK, UP AND OVER PULLEY NO.5 AS SHOWN.

3. CONNECT THE PEC DEC CABLE 2750MM (25)

TAKE PEC DEC CABLE ONE END TO PEC DEC ARM AS PICTURED IN PEC DEC ASSEMBLY, USING M10*30MM HEX BOLT (59), M10 NUT (65), M10 WASHER (72) AND M10 NYLON NUT (68) TO SECURE CABLE TO ASSEMBLY, THEN THREAD THE OTHER END OF CABLE OVER PULLEY NO.6, DOWN AND AROUND PULLEY NO.7, IN PEC DEC PULLEY BLOCK (22) UP AND OVER PULLEY NO.8, USING M10*30MM HEX BOLT (59), M10 NUT (65), M10 WASHER (72) AND M10 NYLON NUT (68) TO SECURE CABLE TO ASSEMBLY.

4. START THE BOTTOM CURL BAR CABLE 3350MM (26)

START BY THREADING THE END OF THE CABLE WITHOUT THE BALL UNDER PULLEY NO.9, UNDER PULLEY NO.10, UP AND AROUND PULLEY NO.11, IN FLOATING PULLEY BLOCK, DOWN AND UNDER PULLEY NO.12, UP AND AROUND PULLEY NO.13, IN FLOATING PULLEY LOCK, DOWN AND AROUND PULLEY NO.14, UP AND WITH CHAIN HOOK (36) TO CHAIN (27) TO TIGHTEN.

NOTE: IF YOU FIND THAT THE CABLES ARE NOT LONG ENOUGH, USE THE EXERCISE CHAIN AS AN EXTENSION WITH CHAIN HOOK AS CONNECTORS.

INSTALL WEIGHT COVER (76) TO TOP CROSS BEAM (10) AND LEFT BASE (03). SECURE USING M8*15MM BOLTS (64), M8 WASHER (73) AS SHOWN.

ATTACH HAND GRIP (35) TO LAT BAR (30) AND CURL BAR (31).

※ **WARNING:** MAKE SURE ALL CABLES DO NOT RUN OUT OF TRACK FROM ANY OF PULLEYS WHILE YOU ARE IN USE EVERYTIME.



ABDOMINAL CRUNCH



ARM CURL



BENCH PRESS



BUTTERFLY



CHEST CABLE CROSS

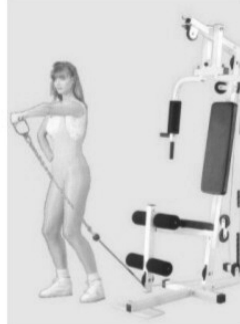

FRONT SHOULDER RAISE



MID ROW

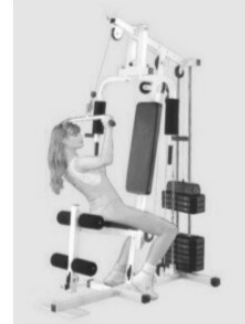

FRONTAL LAT ROW

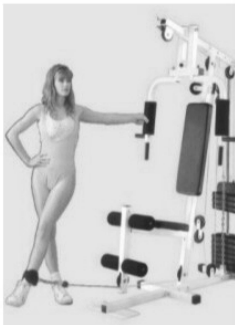

INNER THIGH KICK

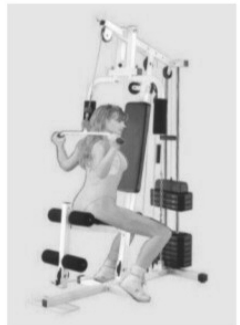

LAT PULL DOWN

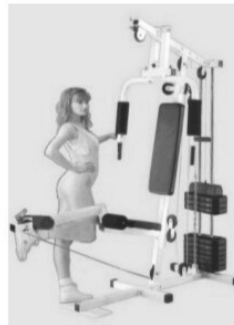

LEG CURL

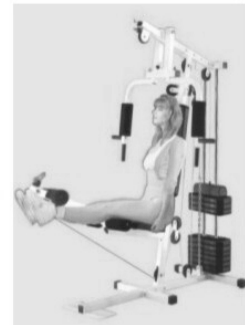

LEG EXTENSION

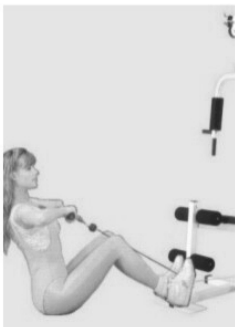

LOW ROW



MILITARY PRESS

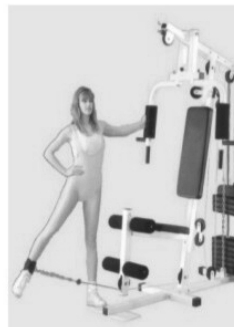

OUTER THIGH KICK

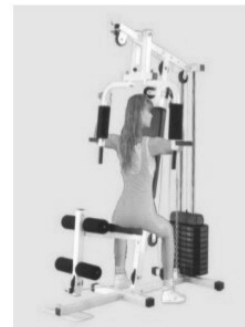

REAR DELT FLIES

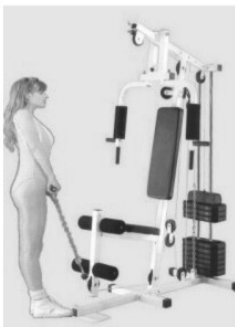

SHOULDER SHRUG

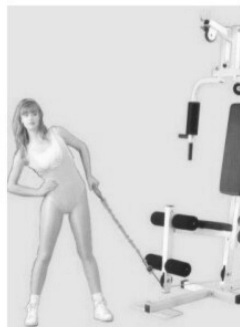

SIDE BEND



TRICEP PUSH DOWN



UP RIGHT ROW



Distributed Exclusively by:
GPI Sports & Fitness
275 Wellington Road
Mulgrave, VIC, 3170
Australia.