

# BODYCRAFT

## F602v2 FLAT / INCLINE / DECLINE UTILITY BENCH OWNERS MANUAL

### Serial Number Location

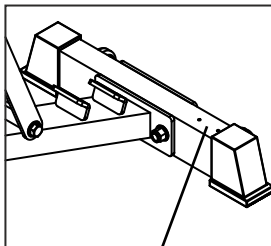

Record your Serial number  
and purchase date here:

S/N \_\_\_\_\_

PURCH.DATE: \_\_\_\_\_

DEALER: \_\_\_\_\_

\_\_\_\_\_

\_\_\_\_\_

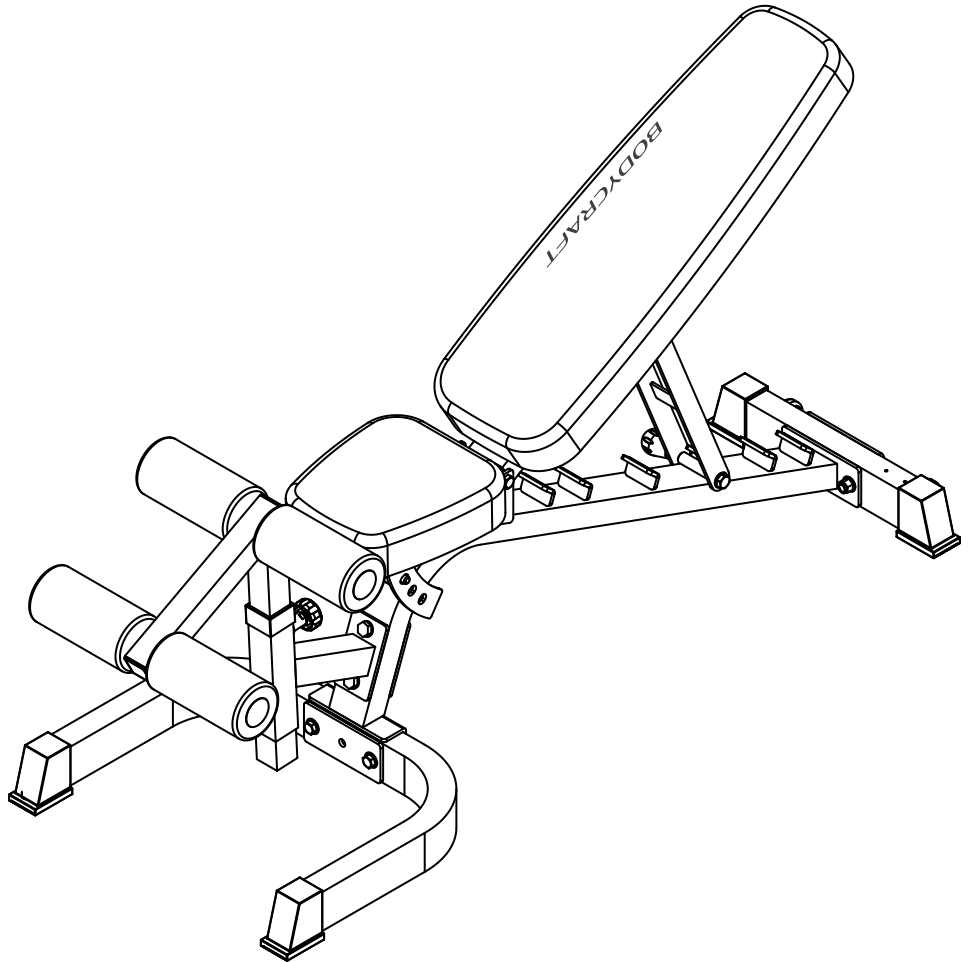

Model No. F602v2  
**BODYCRAFT**  
a division of Recreation Supply Inc.

Recreation Supply, Inc.  
7699 Green Meadows Dr.  
Lewis Center, OH 43035

## **Congratulations and Thank You!**

Thank you for selecting the ***Bodycraft F602v2 Flat Incline Decline Bench (FID)***. The Bodycraft F602v2 offers an impressive array of strength training exercises to develop every major muscle group of the body. Whether your goal is cardiovascular fitness, a shapely, toned body or dramatic muscle size and strength, the Bodycraft F602v2 will help you achieve the results you want. For your safety and benefit, read this manual and the accompanying literature before using the Bodycraft F602v2. Keep this manual for future reference. If you have additional questions, please call your local Bodycraft F602v2 Dealer or our **customer service department at 800-990-5556** Monday through Friday, 9 am until 5 pm Eastern Standard Time.

## **Important Safety Notes**

There is a risk assumed by individuals who use this type of equipment. Before beginning this or any other exercise program consult your physician. This is especially important for individuals over the age of 35 or persons with preexisting health problems. Recreation Supply, Inc. assumes no responsibility for personal injury or property damage sustained by or through use of this product.

- 1. This product must be assembled on a flat, level surface to assure its proper function.**
- 2. Clean pads and frame on a regular basis. We recommend warm, soapy water. Do not use harsh or abrasive chemicals.**
- 3. Inspect and tighten all parts before every use. Replace any worn parts immediately. Failure to do so may result in serious injury.**
- 4. Keep children away from the BODYCRAFT F602v2 at all times.**
- 5. Keep your hands away from cables and pulleys during operation.**
- 6. Keep your hands away from moving parts other than the designated handles.**
- 7. When adjusting the seat, make sure the spring pin is fully engaged. If not, the seat may slip and cause serious injury.**
- 8. Make certain all cables are seated within the pulleys before every use.**
- 9. Exercise with care to avoid injury.**
- 10. If you are unsure about the proper use of the BODYCRAFT F602v2 Bench call your local BODYCRAFT dealer or our customer service department.**

## **QUESTIONS?**

As a quality exercise equipment supplier we are committed to your complete satisfaction. If you have questions, or find missing or damaged parts, we will guarantee your complete satisfaction through our authorized dealer service centers or our home office customer service department. Please call your local dealer for assistance or **BODYCRAFT** at 800-990-5556 (9 AM - 5 PM) EST. Our trained technicians will provide immediate assistance to you, free of charge.

# F602<sub>v2</sub> Bench Assembly Parts List



**NOTE: IF A PART IS MISSING, IT LIKELY HAS BEEN PRE-INSTALLED FOR QUALITY CONTROL PURPOSES. PLEASE PROCEED WITH ASSEMBLY.**

\*Parts images are not to scale.

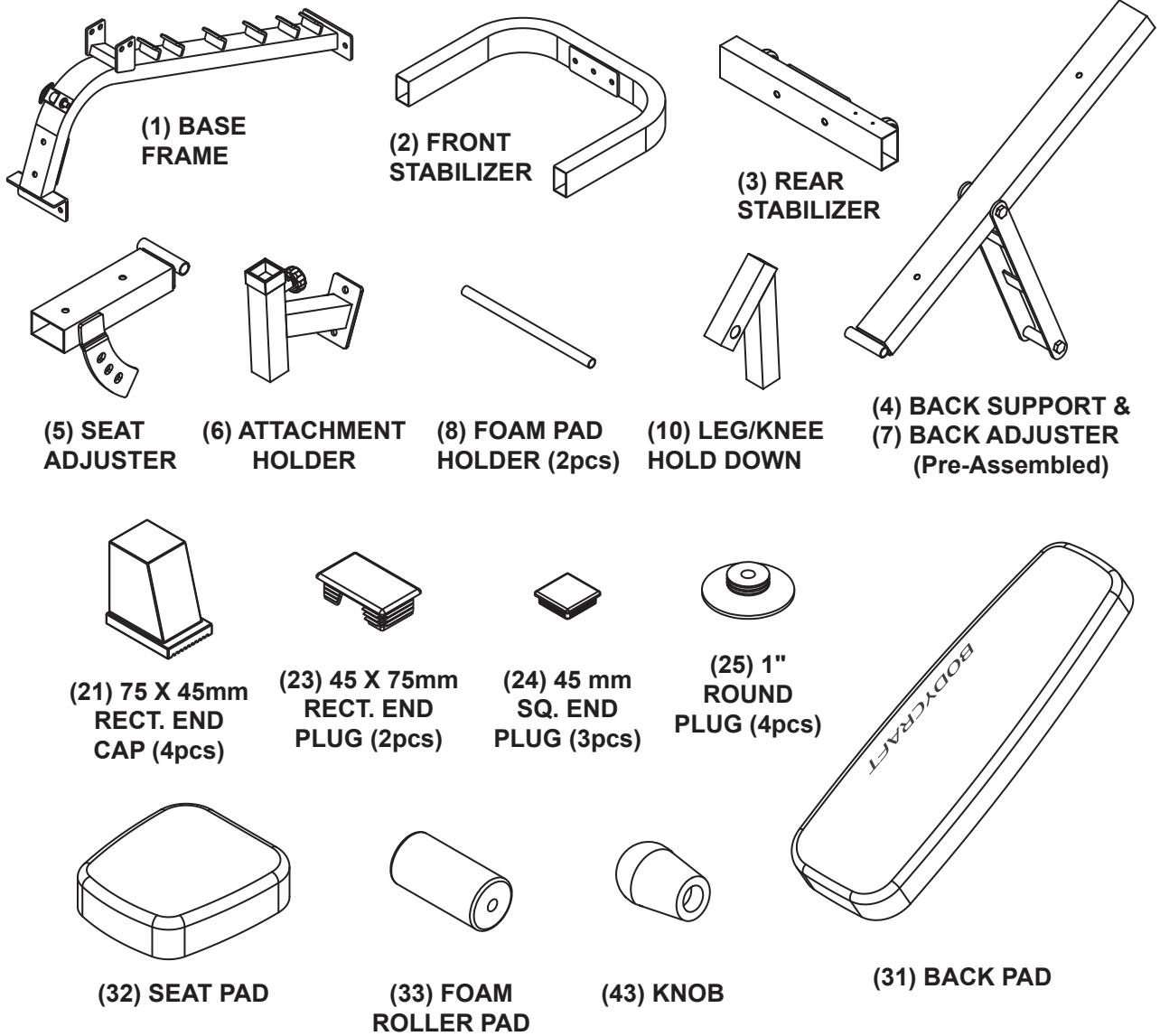

| NO. | DESCRIPTION                 | QTY. |
|-----|-----------------------------|------|
| 51  | 1/2" X 5" HEX HEAD BOLT     | 2    |
| 53  | 1/2" X 3" HEX HEAD BOLT     | 6    |
| 54  | 3/8" X 2-3/4" HEX HEAD BOLT | 4    |
| 55  | 1/2" FLAT WASHER            | 12   |
| 56  | 3/8" FLAT WASHER            | 4    |
| 57  | 1/2" NYLON NUT              | 8    |

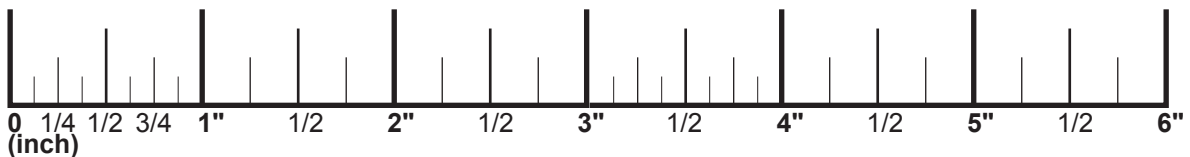
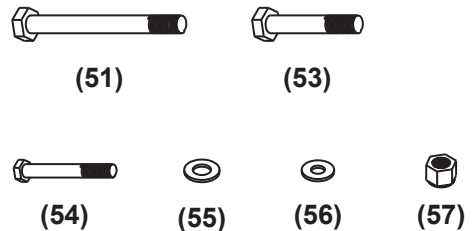

## Recommended Tools

**Utility Knife** (To cut packaging and banding)  
**Ratchet with 9/16" and 3/4" Sockets**  
**9/16" and 3/4" Combination Wreches**  
**Adjustable Wrench**  
**Rubber Mallet**

## Assembly Instructions



**NOTE:** Before installing the plastic parts, please allow them to acclimate to room temperature or they may be damaged. **CAREFULLY** install all plastic components with Rubber Mallet.

**PLEASE REFER TO THE EXPLODED VIEW ON THE NEXT PAGE FOR ASSEMBLY.**

1. Carefully install END CAPS(21) onto FRONT STABILIZER(2) and REAR STABILIZER(3) using a rubber mallet.
2. Bolt the FRONT STABILIZER(2) and REAR STABILIZER(3) to the MAIN FRAME(1), using four BOLTS(53), eight WASHERS(55) and four NUTS(57). Tighten.
3. Bolt ATTACHMENT HOLDER(6) to MAIN FRAME(1), using two BOLTS(53), four WASHERS(55) and two NUTS(57). Tighten.
4. Install END PLUGS(23) into SEAT ADJUSTER(5) and BACK SUPPORT(4) using a rubber mallet.
5. Attach SEAT ADJUSTER(5) and BACK SUPPORT(4) to MAIN FRAME(1), using BOLT(51) and NUT(57). (NO WASHERS) (Any moving parts that do not pivot freely, slightly loosen the nuts counterclockwise at the pivot points to allow movement, but not too much to allow play or wobble.)
6. Attach SEAT PAD(32) to SEAT ADJUSTER(5) and BACK PAD(31) to BACK SUPPORT(4), using BOLT(54), WASHER(56). Tighten.
7. Install 50mm SPACER CAP(22) onto ATTACHMENT HOLDER(6).□  
□
8. Insert LEG/KNEE HOLD DOWN(10) into ATTACHMENT HOLDER(6). Using Pop-Pin.
9. Install END PLUGS(24) into LEG/KNEE HOLD DOWN(10) with Rubber Mallet.
10. Insert FOAM PAD HOLDERS(8) into the LEG/KNEE HOLD DOWN(10) and slide FOAM ROLLER PAD(33) onto each end of the FOAM PAD HOLDER(8) and secure with 1" ROUND CAP PLUG(25) using rubber mallet.
11. Install KNOB(43) onto the threaded end of the pre-installed BOLT(63) located at the lower part of the BACK ADJUSTER(7). Tighten.

**ASSEMBLY IS COMPLETE!**

**PLEASE RECHECK THAT ALL COMPONENTS ARE TIGHT AND SECURE.**

# EXPLODED VIEW

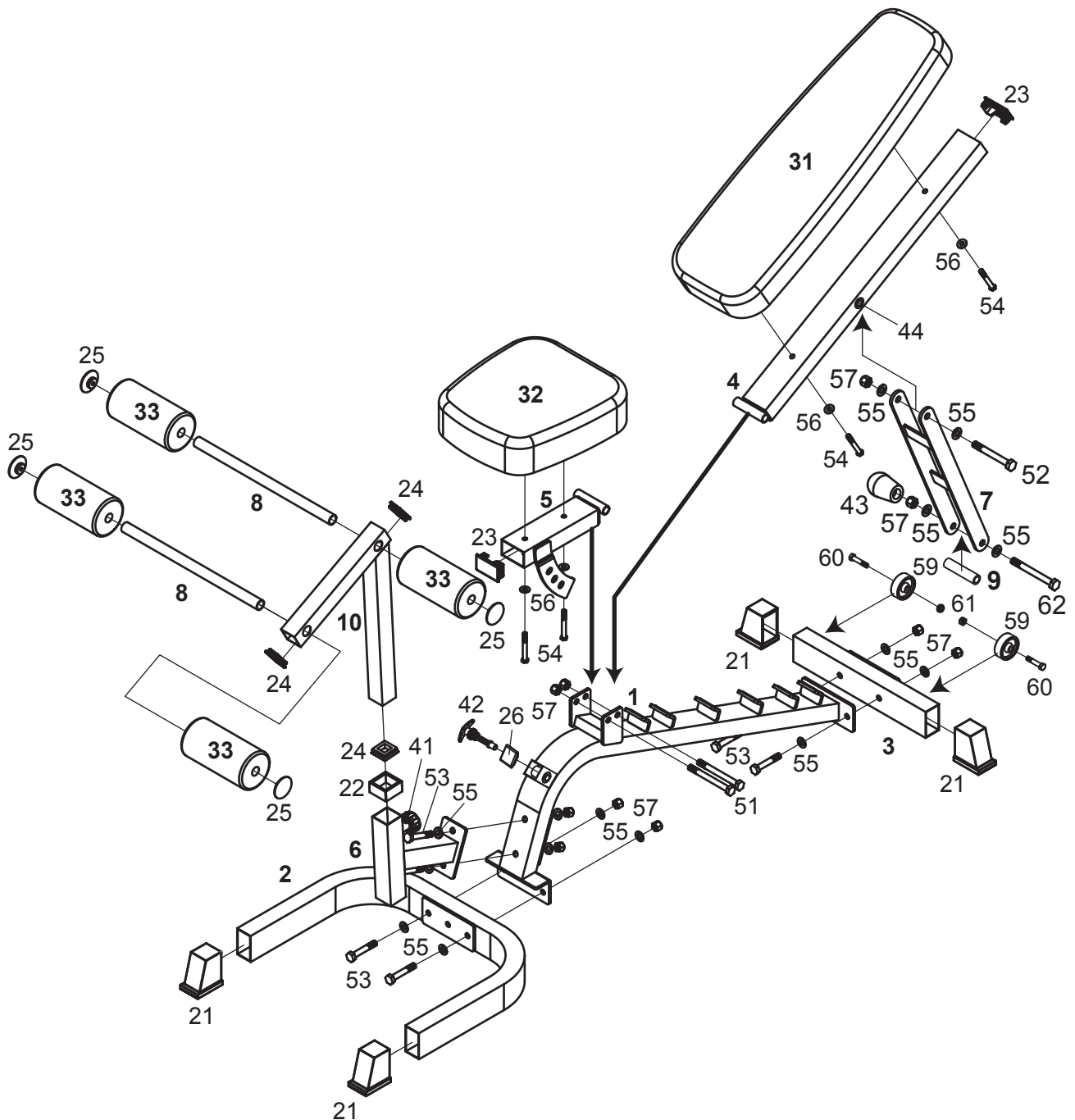

# COMPLETE PARTS CHART

| NO. | DESCRIPTION        | QTY. |
|-----|--------------------|------|
| 1   | MAIN FRAME         | 1    |
| 2   | FRONT STABILIZER   | 1    |
| 3   | REAR STABILIZER    | 1    |
| 4   | BACK SUPPORT       | 1    |
| 5   | SEAT ADJUSTER      | 1    |
| 6   | ATTACHMENT HOLDER  | 1    |
| 7   | BACK ADJUSTER      | 1    |
| 8   | FOAM PAD HOLDER    | 2    |
| 9   | BRACE              | 1    |
| 10  | LEG/KNEE HOLD DOWN | 1    |

| NO. | DESCRIPTION              | QTY. |
|-----|--------------------------|------|
| 21  | 75 X 45mm RECT. END CAP  | 4    |
| 22  | 50mm SPACER CAP          | 1    |
| 23  | 45 X 75mm RECT. END PLUG | 2    |
| 24  | 45mm SQ. END PLUG        | 3    |
| 25  | 1" ROUND PLUG            | 4    |
| 26  | 38mm SQ. PLUG            | 1    |

| NO. | DESCRIPTION | QTY. |
|-----|-------------|------|
| 31  | BACK PAD    | 1    |
| 32  | SEAT PAD    | 1    |
| 33  | FOAM PAD    | 4    |

| NO. | DESCRIPTION   | QTY. |
|-----|---------------|------|
| 41  | QUICK RELEASE | 1    |
| 42  | POP PIN       | 1    |
| 43  | KNOB          | 1    |
| 44  | BUSHING       | 6    |

| NO. | DESCRIPTION                  | QTY. |
|-----|------------------------------|------|
| 51  | 1/2" X 5" HEX HEAD BOLT      | 2    |
| 52  | 1/2" X 4" HEX HEAD BOLT      | 1    |
| 53  | 1/2" X 3" HEX HEAD BOLT      | 6    |
| 54  | 3/8" X 2-3/4" HEX HEAD BOLT  | 4    |
| 55  | 1/2" FLAT WASHER             | 12   |
| 56  | 3/8" FLAT WASHER             | 4    |
| 57  | 1/2" NYLON NUT               | 9    |
| 58  | 1/2" NYLON NUT(THINNER)      | 1    |
| 59  | WHEEL                        | 2    |
| 60  | 5/16" X 1-1/2" HEX HEAD BOLT | 2    |
| 61  | 5/16" NYLON NUT              | 2    |
| 62  | 1/2" X 6" HEX HEAD BOLT      | 1    |

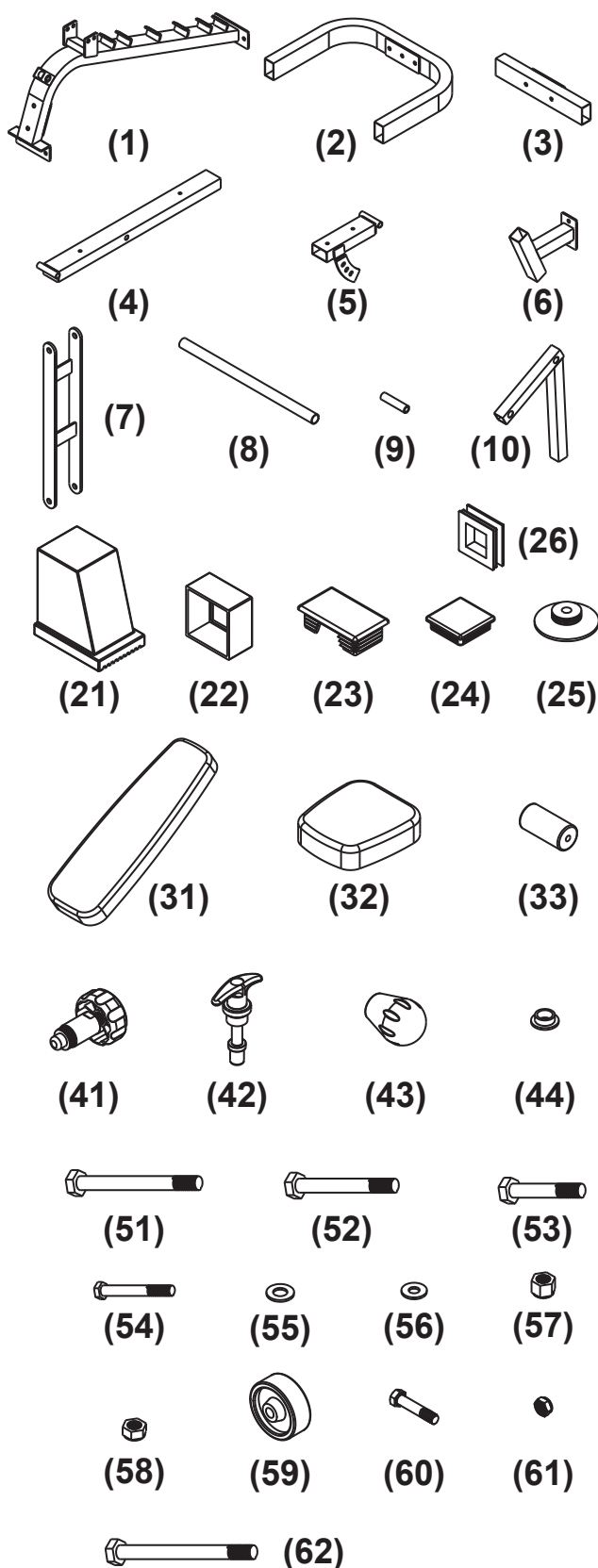

\*Parts images are not to scale.