

OWNER'S MANUAL

Flat Bench

Model #: 302 FB

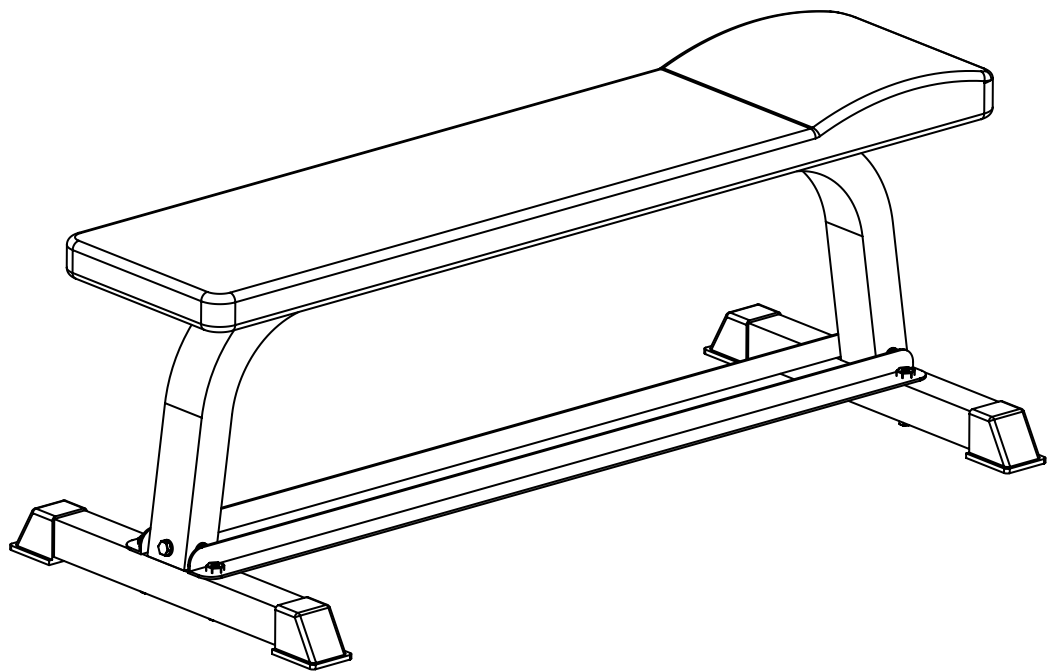

Caution: Read all precautions and instructions in this manual before using this equipment. Save this manual for future reference.

Assembly Instructions

Before Your Begin

This exercise equipment is built for optimum safety. Be sure to read the entire manual before you assemble or operate your equipment. Please note the following safety precautions:

1. Keep children and pets away from the equipment at all times. Do not leave children unattended in the same room with the equipment.
2. Only one person at a time should use the equipment.
3. If the user experiences dizziness, nausea, chest pain, or any other abnormal symptoms STOP the workout at once.
CONSULT A PHYSICIAN IMMEDIATELY.
4. Position the equipment on a clear, level surface. DO NOT use the equipment near water or outdoors.
5. Keep hands away from all moving parts.
6. Always wear appropriate workout clothing when exercising. DO NOT wear robes or other clothing that could become caught in the equipment.
7. Use the equipment only for its intended use as described in this manual. DO NOT use attachments not recommended by the manufacturer.
8. Before using the equipment, always do stretching exercises to properly warm up.
9. Never operate the equipment if the equipment is not functioning properly.

ASSEMBLY INSTRUCTIONS

Place all parts in a clear area and remove the packing materials. We highly recommend that this weight bench be assembled by at least 2 persons.

