

"OJAS BOOKSHELF SPEAKER KIT" MANUAL

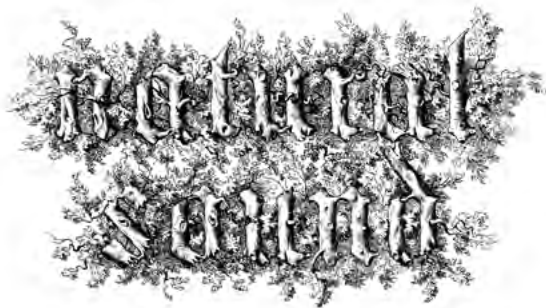

OJAS

### BOOKSHELF SPEAKER

The OJAS Bookshelf Speaker Kit includes everything you need to build a high quality customizable speaker.

### PASSIVE SPEAKER. RECOMMENDED AMP POWER 3 - 100 WATTS

14" W × 12.5" D × 16.5" H

Frequency Response\*: about 50 Hz - about 18 kHz

Sensitivity: 98 dB

Nominal Impedance: 8 ohms (minimum 6 ohms)

Recommended Power: 3-100 watts

### ITEM LIST

- [01] × OJAS Speaker Cabinet (pair)
- [02] × JBL Pro Control 328C Speaker
- [40] × Lamello Cabineo 12
- [01] × Lamello Cabineo 4mm ball head hex driver
- [02] × Dual Ended Satin Nickel Terminal Pair
- [01] × Havelockwool Batt Insulation
- [02] × Belden Speaker Cable, 2 Conductor 16 AWG TC, Unshielded, CM
- [01] × Gasket Tape (8 pieces)
- [02] × Ojas Nameplate
- [08] × Nameplate Screws (#2× $\frac{1}{4}$ " Stainless)
- [02] × Internal Input Wire
- [28] × M4 black screw
- [08] × 8×2  $\frac{1}{2}$ " wood screw
- [12] × 5×35mm wood dowel
- [16] × M4 T-nuts

### NOT INCLUDED

- 8mm or compatible adjustable wrench
- Phillips head screwdriver
- Staple gun
- Wood glue
- Electric Screw Driver
- Hammer/Mallet

### ILLUSTRATIONS

For the purpose of this manual the illustrations depict the left sided bookshelf speaker.

E 1- GLUE UP

Protect your workspace.

Protect the surface you are working on, the floor below and your clothing from potentially getting glue on them.

**NOT INCLUDED:**

- Electric screwdriver or screwdriver handle
- Mallet or Hammer
- Water and rags
- Phillips head screwdriver
- Wood Glue

\* Note that all of the arrows on the part labels point toward either the front or the top of the speaker cabinet.

Start by separating the parts for the Left and Right speakers. Note the difference between the Left Speaker, which would appear on the first line of the description, and the Left Side, which would appear on the second line of the description.

**OJAS**

Artbook

— | SPEAKER

Speaker 1

— | PART

Ojas\_Books1010  
18MM MULTIPLY  
05/01/2020



Part # 27 Pat # 2

### 1.1 - ADD BASS PORT DEPTH PIECES TO BAFFLE

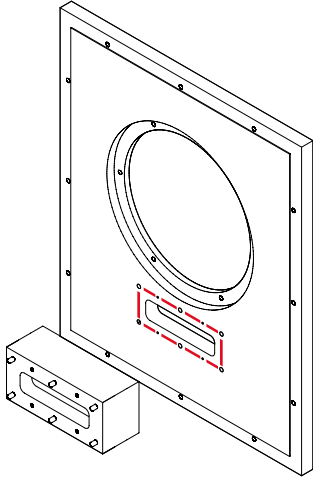

- Push wood dowels into the port depth piece.
- Apply a few small dabs of glue around the port opening on the baffle.
- Press the port piece into the baffle with the dowels pressing into the holes on the baffle.

### 1.2

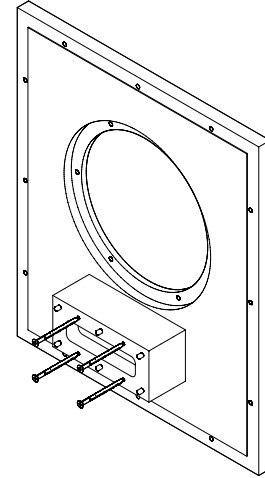

- Use 2 1/2" wood screws to clamp port depth piece into the baffle.



### 1.3 INSTALL THE CABINEO'S

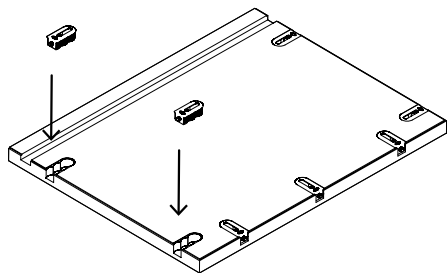

- Install all of the Cabineo connectors into the mortices on the Top, Bottom and Sides.
- Lay out the panels and gently press the connectors into the mortices. Use a Mallet or Hammer to pound them flush with the surface of the workpiece. If using a metal hammer you should put a piece of scrap wood or similar material between the hammer and the workpiece to avoid marring the cabineos or the wood.

### 1.4 INSTALL THE TOP

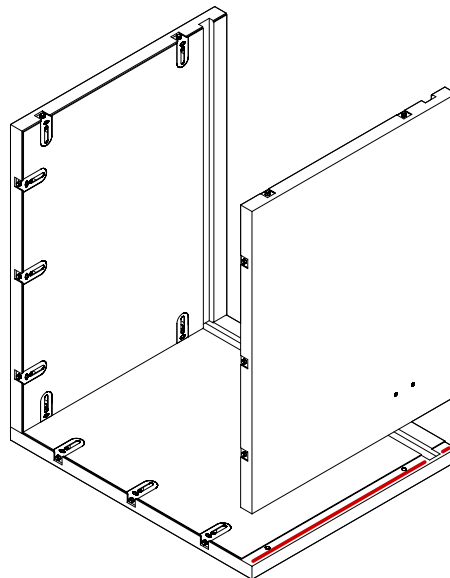

To glue the Left Side onto the bottom:

- Apply a small bead of glue from the front to the back of the left side of the bottom.
  - Place the left side panel onto the bottom so the Cabineo connectors align with the pilot holes in the bottom.
  - With the Cabineo driver on your screwdriver or electric drill screw both Cabineos into the bottom.
  - Wipe any glue that squeezes out as you tighten each screw.
- Repeat above steps to glue the Right Side to the Bottom.

### 1.5 INSTALL THE CLEAT

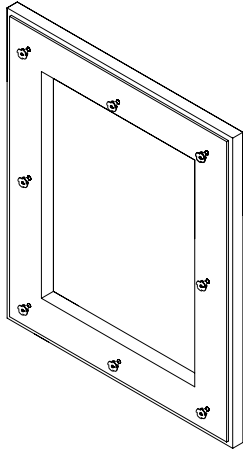

- To install T-nuts, place the cleat with the rebate boarder facing up.
- Set each T-nut in the holes by pressing down until the flanges on the T-nut touch the cleat.
- Hammer in the T-nuts; the flanges of the T-nut should be recessed in the wood.

### 1.6 INSTALL THE CLEAT

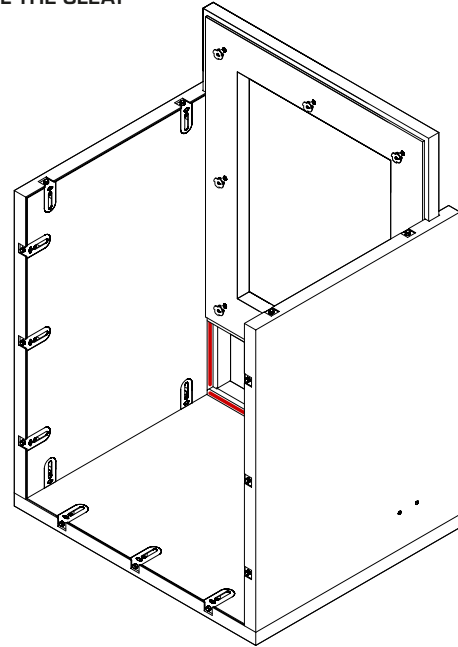

- Insert Cleat into the rebate at the back of the speaker.
- Apply a bead of glue across the bottom of the rebate.
- Apply a bead of glue to the top 2/3 of the side rebates. The Cleat will pull this glue to the bottom as it slides in.
- Slide the Cleat into the rebate.

**\* MAKE SURE THAT THE SIDE OF THE CLEAT WITH THE REBATE ON IT FACES THE INSIDE OF THE CABINET.**

1.7

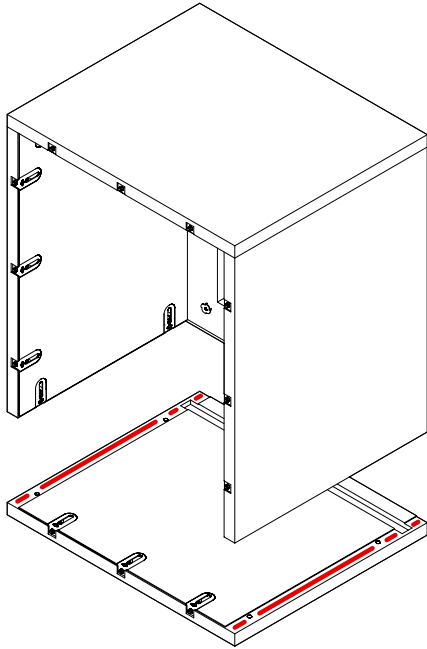

- Glue the top onto the sides
- Move the assembled cabinet to the side.
- Put the top piece, top down, on the work surface.
- Apply glue to the sides and in the rebate across the back.
- Carefully flip the assembled cabinet upside down and lower it onto the top, dropping the Cabineo connectors into the pilot holes.

1.8

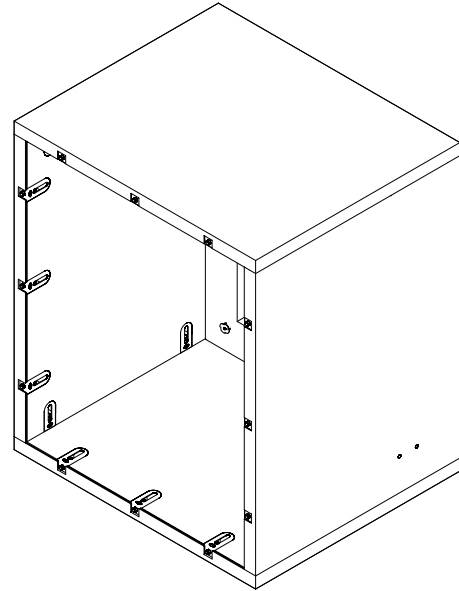

- Tighten the Cabineo connectors into the Top.
- Wipe glue that squeezes out as you tighten each screw.

## 1.9 - INSTALL THE BAFFLE

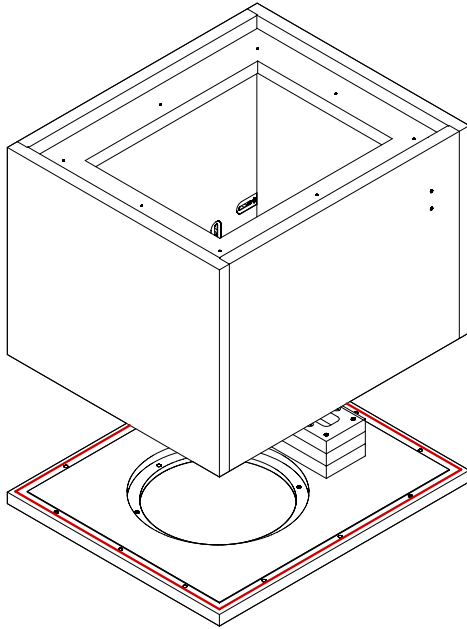

- Move the assembled cabinet to the side and place the baffle face down on your work surface.
- Apply glue all the way around the outside of the baffle.
- Carefully lower the assembled cabinet, Cabineo's down, onto the Baffle, dropping the Cabineo's into the pilot holes.
- Tighten all of the Cabineos and wipe glue squeeze out as you go.

## PHASE FINISHING

# 2

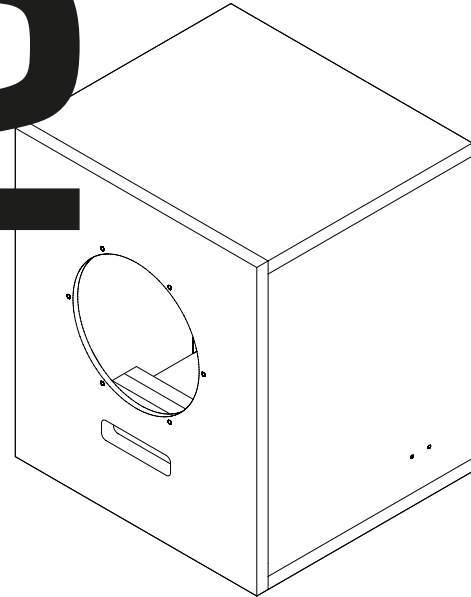

- Finishing is left to the discretion of the individual builder, limited only by their creativity. The obvious options are paint, stains and sealers like waxes and oils. I would also love to see some upholstered cabinets or other less conventional techniques! Another option would be to take the cabinets to a professional paint shop and pay to have them painted to a level not possible to the home builder. When your cabinet is done, you can install the nameplate in the bottom rear corner of the speaker (opposite binding post holes).

# 3

The JBL 328c has very good specs, exceptional build quality and a classic JBL sound. But it is not intended to be installed in a custom tuned wood cabinet the way we are using it. As such we have to do some hacking to remove the ceiling mounting hardware (it's default application). Given the economies of scale that we get working with such a mass produced machine, it's well worth the extra effort.

## TO NOTE

The cone and surrounds (front side) of any speaker are quite delicate. The materials are paper and fabric, and the surrounds have a sticky coating. One should always avoid touching the cone or surrounds as the performance of the speaker can easily be affected by mishandling these parts.

The weight distribution on a speaker is also very awkward. The magnets are very heavy relative to the front part of the speaker. It is much easier to hold the speaker by the magnet as opposed to the front lip, which is counter intuitive to some people. Whenever possible hold the speaker by the magnet.

Prepare JBL 328c coaxial speaker unit for installation.

3.1

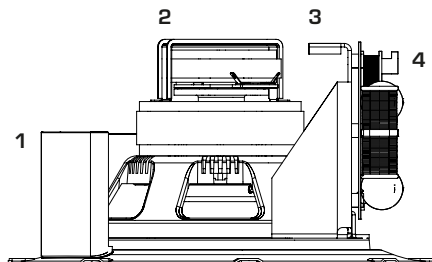

- 1 - LF Woofer
- 2 - HF Compression Driver
- 3 - Crossover Bracket
- 4 - Crossover

· Open the top of the box and remove the styrofoam packaging. You should see the crossover mounted to a bracket and the back of the unit. If not, close the box and open from the other side.

· Lift the speaker out of the box by the crossover bracket and place face down on a clean work surface.

3.2 - VIDEO LINK

· Disconnect all four wires from the fasten connectors on the HF Compression Driver and the LF Woofer. In order to remove these you must pinch a small tab above the rolled contact point. When this tab is pinched the connector will slide off easily. If the connector does not want to slide off with a small amount of pressure do not pull so hard that you could damage the connector

· Just keep trying to find the little tab to pinch.

[Click here for a video illustrating the technique.](#)

3.3

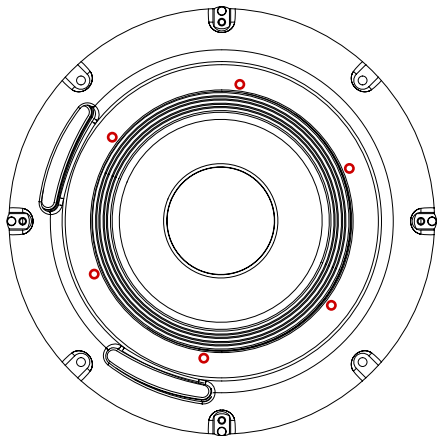

- Carefully flip the coaxial unit over and place it magnet side down. You will need to support it with one hand while you unscrew the 3 screws holding the crossover bracket onto the lip of the speaker.
- \*Take extra precaution not to slip with your screwdriver and pierce the delicate cone or surrounds. When the 3 screws holding the crossover bracket on are removed it will drop down onto your work surface. Set it aside for now.

3.4

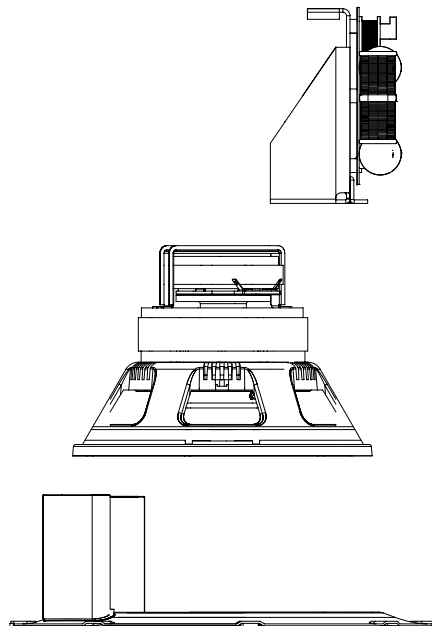

- To remove the remaining 3 screws you will need to hold a wrench on the nut, and the mounting plate with one hand while you unscrew with the other.
- Remove the mounting plate and discard, save or repurpose.
- Carefully set aside speaker unit and crossover.

3.5

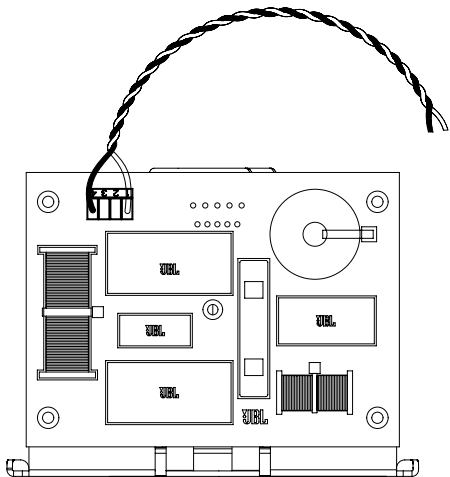

- Insert one end of the internal input wire into the crossover where it says IN+ and IN-. Use the orange wire for (+) and the black wire for (-). Tighten the corresponding screw posts with the small flathead screwdriver to hold the wires in place.
- This connector is called a Phoenix Connector. It can be removed from the crossover by pulling directly up from the board.
- Please make sure the Phoenix Connector is firmly set on the board.

3.6

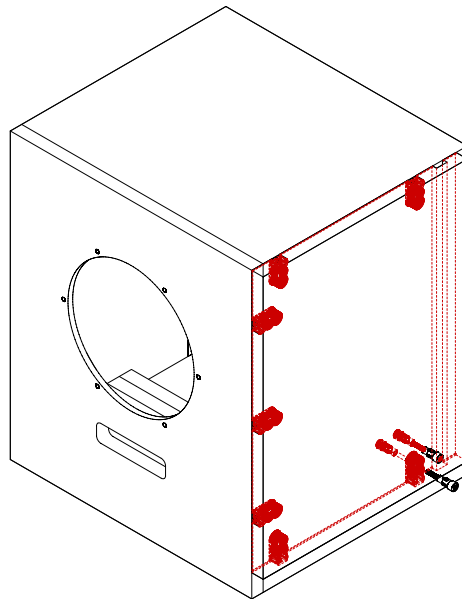

- The Left and Right cabinets are mirrored in one aspect: the side with the speaker terminal binding posts is flipped so that you can either expose them both or hide them both against the wall.
- Install the binding posts through the holes on the side of the cabinet.
- Now that your speaker cabinet is put together, it's time to add the insulation. To Install the natural wool acoustic damping material, line the bottom of the cabinet and the side opposite of the binding posts with the long piece of insulation.



3.7

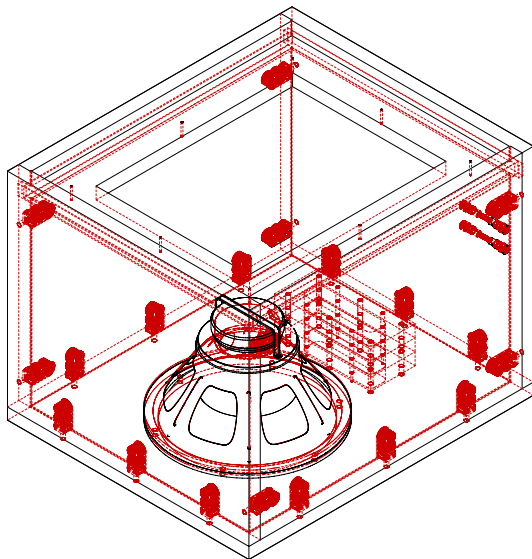

- Place the cabinet face down on your work surface.
- The coaxial unit will drop into the rebate around the full cut-out, self-centering the driver.
- The only thing we have to do is rotate it so that it's at the right angle to accommodate the proper placement of the crossover bracket.

3.8

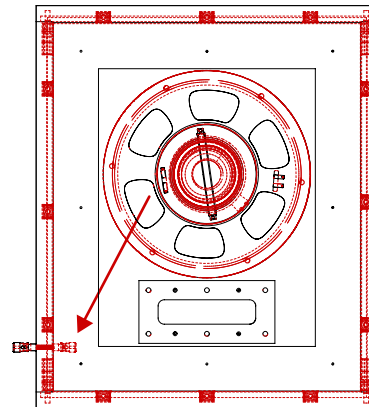

- Rotate the unit until the mounting holes in the lip of the speaker line up with the mounting holes in the cabinet.
- Fasten the 3 screws and hex nuts through the 3 mounting holes on the side opposite the binding posts. An easy way to do this with one person is to position the cabinet with one or two of the mounting holes hanging off the edge of your work surface and inserting the screws from below. Use a few staples on each surface to hold it in place. Center the small piece of insulation on the back door and staple in place.

3.9

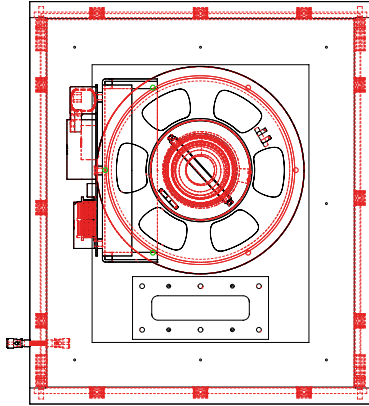

- Now you can safely stand the cabinet up and get a first look at the cabinet with the driver installed.
- From the front of the speaker, put a screw through the far right hole. Then, looking into the back of the cabinet, place the center threaded hole on the crossover bracket onto this screw and gently tighten it so that the bracket can still easily rotate on this screw.
- With the center screw gently tight you should be able to screw the two remaining screws into the crossover bracket. You might have to wiggle the

bracket to get these screws to find their threaded holes, which is why we leave the center screw loose enough to allow for this movement. If you're having trouble finding either of these holes, make sure that the other screws holding the bracket on are loose enough that it can freely move.

- With your wrench and screwdriver, tighten all 6 mounting screws until the gasket on the lip of the speaker is gently compressed. You do NOT need to tighten these screws until the frame of the speakers is touching the cabinet. Also keep an eye on the heads of the screws as you tighten, so you don't over tighten them and damage your finish.

3.10

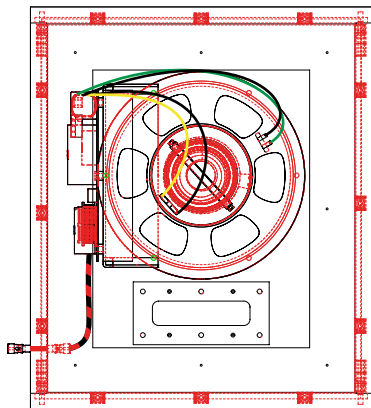

- Connect the two driver inputs to the wires coming off of the crossover:
  - Black and Yellow to the high frequency driver at the back of the unit
  - Black and Green to the low frequency driver at the front of the unit
- From the inside of the cabinet, insert the Internal Input Wire into the push down post heads, Red to Orange and Black to Black.
- The input wire should be long enough to reach the binding post on either speaker.

3.11

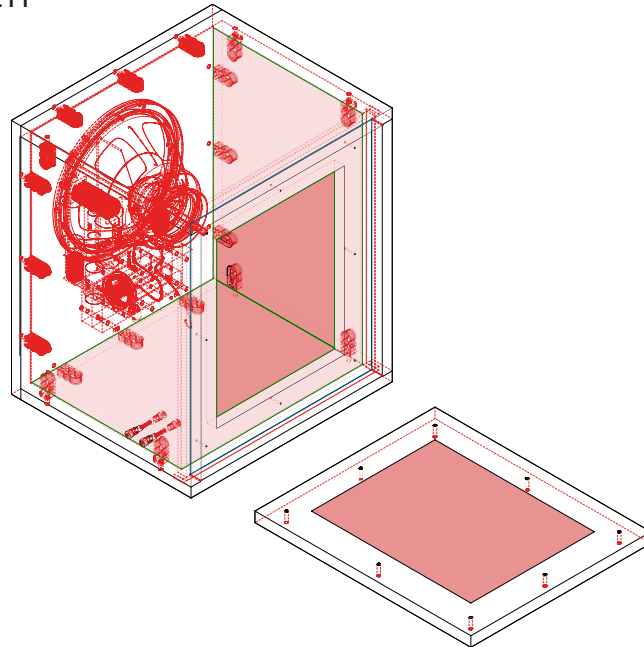

- To install the natural wool acoustic damping material line the bottom of the cabinet and the side without the crossover with the long piece of insulation. You will need to cut a slit in the wool to allow the wires to pass through the insulation on speaker 1.
- Use a few staples on each surface to hold it in place.
- Center the small piece of insulation on the back door and staple in place.

3.12

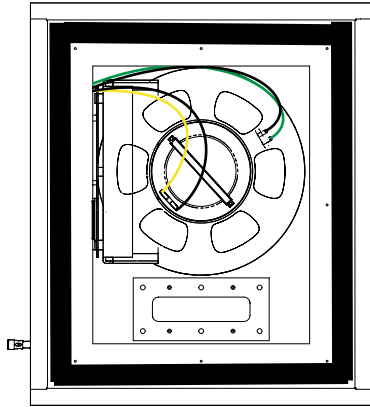

· To Adhere gasket tape to the outside of the cleat, peel the back off of the lengths of gasket tape. Stick the tape onto the outside of the cleat. The longer lengths go on the sides and the shorter lengths go on the top and bottom. Gasket tape can overlap slightly in the corners because it compresses very flat.

3.13

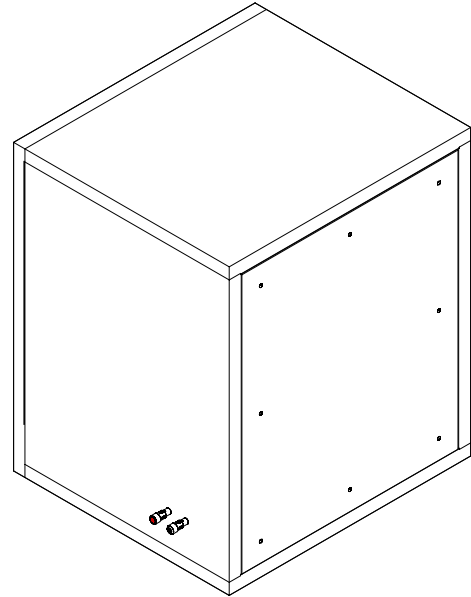

· Use the supplied black M4 screws to screw the back door in place. Use enough torque to compress the gasket tape, but not enough to pull the screws through the countersunk holes.

3.14

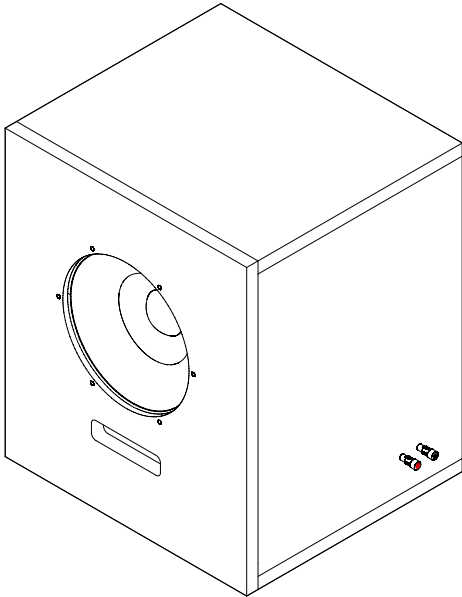

· Now you are ready to connect the speaker to your amplifier and hear it for the first time. You may notice that over the first several days that the bass opens up and the highs pleasantly soften as the driver goes through a "burn in" period. I find that this is less apparent with this unit than some, but as a general practice it's usually a good idea to gently bring your new speakers into the world as their suspensions can be a little stiff when they are brand new. Enjoy!

## CARE AND MAINTENANCE

### EXTERIOR CABINET

OJAS Bookshelf Kit Cabinet is delivered unfinished to allow you to personalize the cabinet as desired. The cabinet is composed of plywood, and may be painted or stained, allowing you to exhibit the natural wood grain. Or, it could be treated with varnish, lacquer, polyurethane, or wax, which tends to show off a glossy or satiny sheen. Do not use cleaners that will strip off or damage your finish. For general care and maintenance, use clean, lint-free, and soft cloths on the speakers, like a cotton or microfiber towel.

### SPEAKER CONES

Delicate! Cones are easily damaged. Do not use liquids when cleaning speaker cones.

### SPEAKER TERMINALS

Unplug all connected cables prior to cleaning. Do not use water based cleaning solutions or compressed air to remove dust.

**\*\*Please refer to Manufacturer Specifications and Warranties Links specific care instructions for each product component.**

#### **SAFETY WARNING**

- Recommended Ages 10+
  - Small Parts – Chocking Hazard
  - Carefully unpack the speaker to avoid damage.
  - Follow OJAS Instruction Manual and each manufacturer manual provided in “*Manufacturer Specifications and Warranties Links*” carefully. If the instructions are not correctly performed or adhered to, damage or destruction to the component part or the entire product may occur. *Canary Yellow assumes no responsibility for improper installation of hardware or for any personal injuries or product damages resulting from improper installation.*
  - Avoid exposing the speaker to direct moisture and extended or intense sunlight.
- Some components used in the OJAS Kit contain California Proposition 65 Warnings. Please review all warnings and safety information provided by each component manufacturer.

 **WARNING: Cancer and Reproductive Harm**  
[www.P65Warnings.ca.gov](http://www.P65Warnings.ca.gov)

#### **MANUFACTURER SPECIFICATION**

##### **LAMELLO CABINEO 8 / CABINEO 12**

<https://www.lamello.com/product/bohrenfraesen-verbinder/cabineo-8-cabineo-12/>

##### **DUAL ENED SATIN NICKEL TERMINAL PAIR**

<https://www.parts-express.com/parts-express-dual-ended-satin-nickel-binding-post-speaker-terminal-pair--091-1156>

##### **HAVELOCKWOOL BATT INSULATION**

<https://havelockwool.com/wp-content/uploads/2019/11/Havelock-data-sheet-10.pdf>

##### **BELDEN SPEAKER CABLE**

[https://catalog.belden.com/index.cfm?event=pd&p=PF\\_9497&tab=downloads](https://catalog.belden.com/index.cfm?event=pd&p=PF_9497&tab=downloads)

##### **JBL PRO CONTROL 328C**

<https://jblpro.com/en/products/control-328c>

Limited Warranty\*:

<https://gallery.canary---yellow.com/terms-of-use>

Return Policy\*:

<https://gallery.canary---yellow.com/terms-of-use>

Please note, other than as provided Some products are warranted thru the manufacturer and may require return shipment, postage paid, directly to the manufacturer. See the detailed warranty instructions on the product detail links provided under "Manufacturer Specifications and Warranties Links."

For inquiries:

[info@ojas.nyc](mailto:info@ojas.nyc)

\*URL's subject to change due to periodic website changes or updates.