



DESCRIPTION

With its clean and elegantly fluted lines, the Ancerre Designs Momo bath introduces a sense of luxury to your bathing experience. Immerse yourself in a deep, immersive soak, courtesy of the Momo freestanding bath. Crafted with sleek, one-piece seamless acrylic construction, it not only ensures exceptional durability but also incorporates unique details, elevating the overall aesthetic and indulgence of your bath.

KEY FEATURES

- Material: Acrylic with Fiberglass Reinforcement.
- Water Capacity : 71 Gallons.
- Including Adjustable Leg Levelers.
- Inclusive of a pop-up drainer and flexible hose (Floor drain rough-in are not included).
- With Built-in overflow for added convenience.
- Tub Filler not included.
- cUPC Certificate.
- 3 Years Warranty.
- Unrivaled comfort achieved through impeccably designed ergonomic structure.
- Non-porous surface for easy cleaning and maintenance.
- Enduring, fade-resistant color maintains vibrancy over time.
- Streamlined and expeditious installation process.

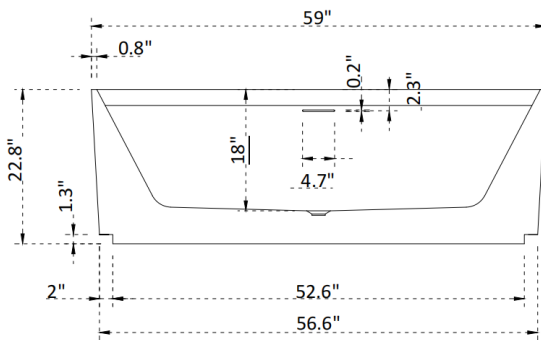

Front View

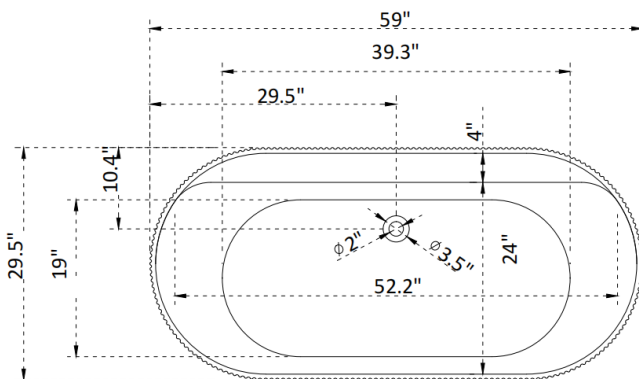

Top View

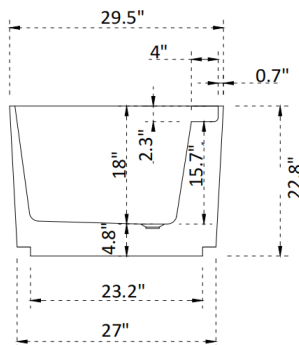

Side View

! **DISCLAIMER:** Following installation, refrain from caulking the tub base initially. Securely fasten all connections and thoroughly inspect for water seepage to validate correct installation. Fill and drain the tub multiple times, checking for leaks before applying caulking.

Product Size : 59"W x 29.5"D x 22.8"H

Package Size : 63"W x 33"D x 30"H

Net Weight: 105 lbs

Gross Weight: 220 lbs

Color Finish: White (Smooth Matte)

Certification:

