



Power Xpress™ Dual Bollard Charge Station Installation Guide



en Installation Instructions

Technical Support
USA: 1-877-805-EVSE (3873)

Copyright © 2016 Bosch Automotive Service Solutions Inc.
All rights reserved.

The information, specifications, and illustrations in this guide are based on the latest information available at the time of printing. Bosch Automotive Service Solutions Inc. reserves the right to make changes at any time, without notice.

Table of Contents

1.0 Installation Safety	2
2.0 Installation Contents: Bollard and EVSE	2
2.1 Power Xpress EVSE (EL-50600-300) for Bollard Charge Station	2
2.2 Bollard and Hardware (EL-50600-500)	2
3.0 Tools Suggested for Installation (Not Provided)	3
4.0 Materials Required for Installation	3
5.0 Applicable Electrical Systems	3
5.1 220/240V Single Phase (North America)	3
5.2 208V 3-Phase Wye Connection (North America)	3
5.3 240V 3-Phase Delta Connection (North America) with Center Tap on One Leg	4
5.4 230V Above Ground (Europe) / 230V Single Phase	4
6.0 Electrical Requirements for Battery Charging	4
7.0 Amperage and Breaker Parameters	5
8.0 Standard Installation	6
9.0 EVSE Power and Status LED Indications	13
10.0 Troubleshooting	13
10.1 Ground Fault Circuit Interrupt (GFCI) Tripped	14
10.2 Missing Ground	14
11. Limited Warranty	14

1.0 Installation Safety



SAVE THESE IMPORTANT SAFETY INSTRUCTIONS

This guide contains important instructions that must be followed during the installation of the electric vehicle supply equipment (EVSE). All instructions should be carefully read before installation of the EVSE.



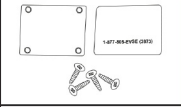

- ⚠ WARNING:** Turn OFF the circuit breaker at the service or distribution panel before performing any electrical work or repairs.
- ⚠ WARNING:** The EVSE should be installed by a licensed electrician in accordance with all local electrical codes and ordinances, and all authorities having jurisdiction.
- ⚠ WARNING:** Do not install the EVSE near flammable, explosive, or combustible materials. Do not locate or store flammable, explosive, or combustible materials near the EVSE.
- ⚠ WARNING:** Improper installation of the EVSE can result in personal injury or product damage.
- ⚠ WARNING:** This EVSE installation guide is not a substitute for electrical safety precautions.
- ⚠ WARNING:** Use this EVSE within the specified operating parameters. Failure to do so may result in injury or death.
- ⚠ WARNING:** Locate and install this EVSE in a location where the charge cable will not be stepped on, tripped over, or subject to damage or stress.
- ⚠ WARNING:** The EVSE must be connected to a grounded, metal, permanent wiring system, or an equipment-grounding conductor must be run with the circuit conductors and connected to the equipment grounding terminal on the EVSE.
- ⚠ CAUTION:** Incorrect installation of the EVSE can result in damage to the vehicle's battery and to the Charge Station itself. These damages will void the warranty for the vehicle and the EVSE.
- ⚠ CAUTION:** Do not operate the EVSE in temperatures beyond its operating range of -40°F to +122°F (-40°C to +50°C).

2.0 Installation Contents: Bollard and EVSE (EL-50650-XXXX)



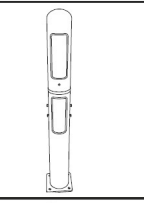

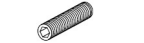









2.1 Power Xpress EVSE (EL-50600-300) for Bollard Charge Station x2

1	EVSE (including attached cable with strain relief and grommet, input/output decals, flag tag, and vehicle coupler)	
1	Decal and cover kit	
1	Cable-management hook	
1	Power Xpress Bollard Charge Station Installation Guide	



2.2 Bollard and Hardware (EL-50600-500)

1	Bollard (including upper and lower plastic covers)	
4	Cable-management retaining screws (pre-installed)	
1	Locating set screw (plastic bag attached to bollard)	
1	Base cover	

3.0 Tools Suggested for Installation (Not Provided)

	Tape measure		Wire cutters
	2-ft Level		Wire stripper
	Pencil		Nonmetallic wire stripper
	Power hammer drill		Masonry drill bit set
	Small flat-blade screwdriver		Needle-nose pliers
	7/16-in. Open-end wrench		Expandable pliers
	1/2-in. Ratchet and sockets		Torque wrench

4.0 Materials Required for Installation

	S00W or SOW 8/3 Service Cord - 16'		Single gang junction box
	Cable grips x4		Wire

5.0 Applicable Electrical Systems

IMPORTANT: The onsite service connection must be properly identified before installation of the EVSE. If you are unsure of the available service connection, consult the local utility company or contact Bosch Electric Vehicle Solutions at 1-877-805-EVSE (3873).

NOTE: The L1, L2, and Ground outputs (H, N for Europe) in the following illustrations correspond to the inputs on the EVSE.

NOTE: For the (earth) ground connection, always connect the neutral at the service panel to earth ground. Ground fault protection is not possible unless the neutral (center tap on the service transformer) is connected to an earth ground.

5.1 220/240V Single Phase (North America)

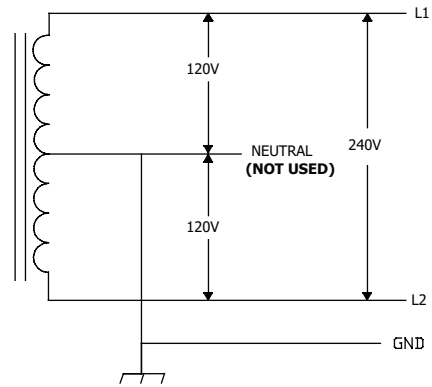

220/240V Single Phase

⚠ WARNING: The EVSE is a single-phase device. Do not connect all three phases of a 3-phase feed. Only three wires are connected, take care that the service transformer secondary connection is known, and the three wires from the main-panel circuit breaker are correctly connected and labeled.

5.2 208V 3-Phase Wye Connection (North America)

Any two of the legs can be used to provide 208V to the EVSE with a Wye-connected secondary. For example, L1 and L2, or L1 and L3, or L2 and L3. Reference the wiring diagram below.

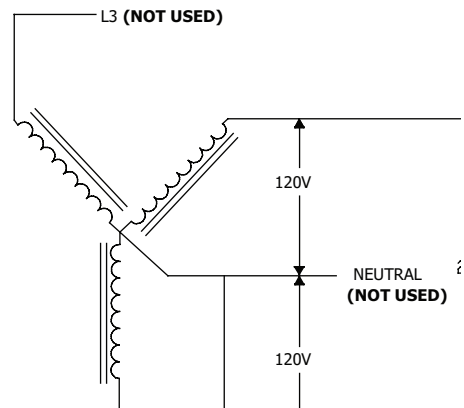

208V 3-Phase Wye Connection

NOTE: A current-carrying neutral is not required for the Charge Station for 208V connections.

⚠ WARNING: The EVSE must be installed by a licensed electrician and in accordance with all local electrical codes, ordinances, and all authorities having jurisdiction.

⚠ WARNING: Do not install the EVSE near flammable, explosive, or combustible materials. Do not locate or store flammable, explosive, or combustible materials near the EVSE.

5.3 240V 3-Phase Delta Connection (North America) with Center Tap on One Leg

One leg must be center-tapped, and only the two phases on either side of the center tap can be used with the delta connection.

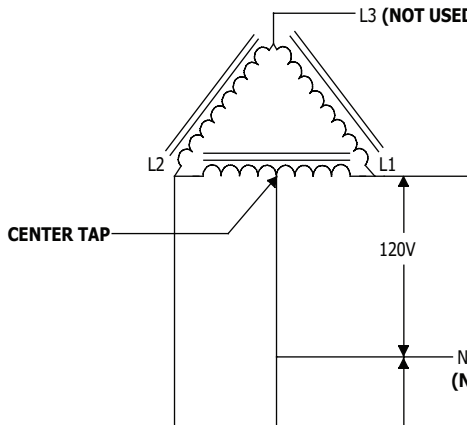

240V 3-Phase Delta Connection

NOTE: The third line (L3 on the illustration of the delta) is 208V, with respect to the neutral, and is sometimes referred to as a "stinger."

⚠ WARNING: Do not use this third line.

NOTE: The two used phases must each measure 120V to neutral or ground.

NOTE: Consult the utility company or the transformer manufacturer's literature to verify that the single leg can supply the required power.

NOTE: The EVSE will only operate properly if it detects the presence of a ground wire connected to a neutral point on the transformer secondary.

⚠ WARNING: Do not use a 3-phase delta-connected transformer secondary without a center tap on one leg and/or without a neutral point available for the required ground connection.

5.4 230V Above Ground (Europe) 230V Single Phase

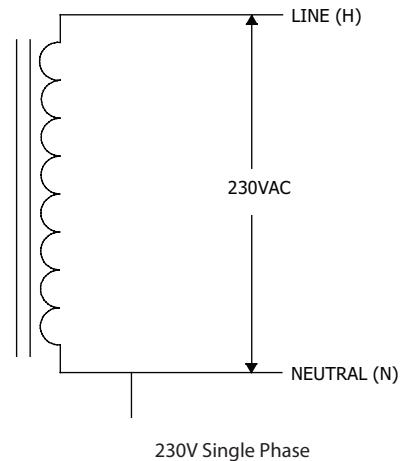

⚠ WARNING: The EVSE is a single-phase device. When connecting the line and neutral wires, take care that the service transformer secondary connection is known, and the wires from the main circuit breaker panel are correctly connected and labeled. The following service connections are primarily used in Europe and Australia (sometimes known as "TT Power Grid"). Please reference the following diagram. The line, neutral, and earth outputs on the illustration correspond to the inputs on the EVSE.

⚠ WARNING: The line connection must measure 230V RMS to neutral. Earth must also be connected to the EVSE.

6.0 Electrical Requirements for Battery Charging

⚠ CAUTION: The AC electrical connection must have a grounded, dedicated service-main. No other loads shall be connected to the same circuit. Use of a non-dedicated circuit could exceed the current rating of the circuit breaker and cause it to trip or open.

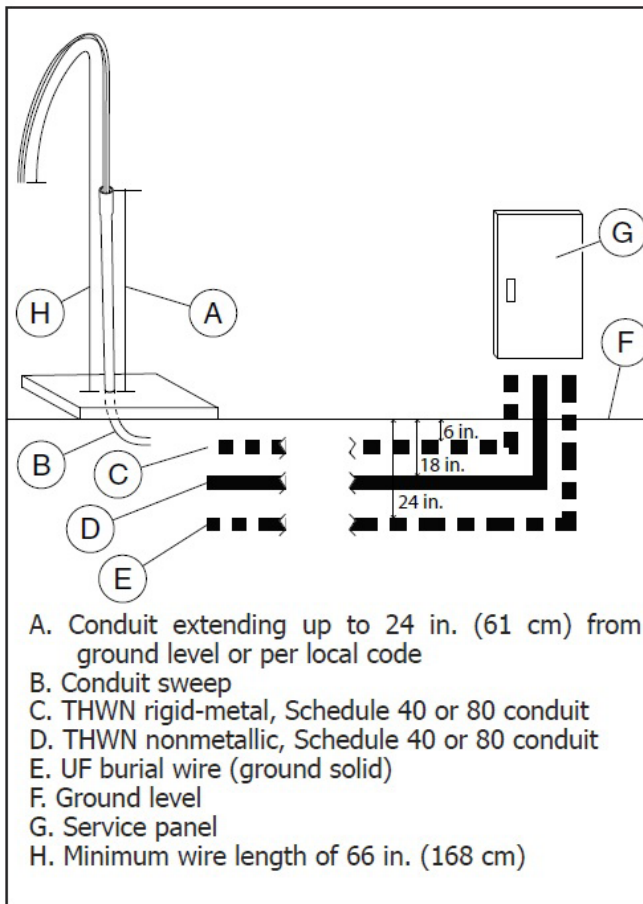

⚠ WARNING: The EVSE must be installed by a licensed electrician in accordance with all national and local electrical codes, ordinances, requirements and all authorities having jurisdiction.

The conduit may extend up to 24 in. (61 cm) from ground level. The wiring should extend 66 in. from the base mounting of the bollard. A sweep is used to direct the circuit from the conduit to the electric circuit from the service panel. The three types of acceptable wire runs are:

- THWN rigid metal Schedule 40 or 80 conduit, buried 6 in. (15 cm) below ground level, or per local electrical code.
- THWN nonmetallic Schedule 40 or 80 conduit, buried 18 in. (46 cm) below ground level, or per local electrical code.
- UF burial wire (ground solid), buried 24 in. (61 cm) below ground level, or per local electrical code.
- Conduit must carry conductors for both charge stations each on a dedicated circuit breaker.

7.0 Amperage and Breaker Parameters: Field Requirements and Adjustments for EVSE Installation (Not Required for 40 Amp Circuit Installation)

1. Unpack the EVSE.

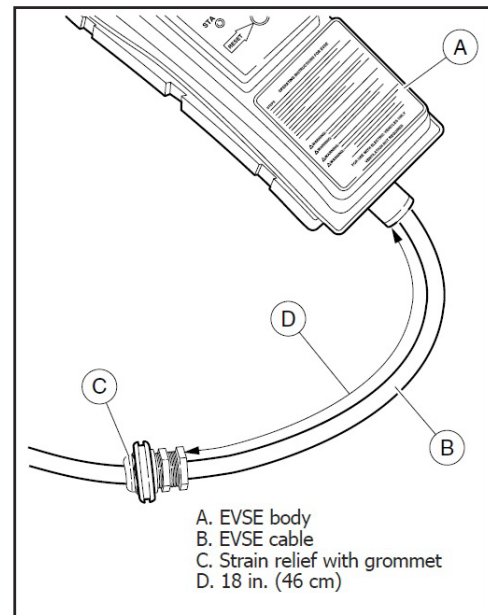

NOTE: The EVSE has been factory set at 30 amp output for a 40 amp circuit. Proceed to "Standard Installation" if installing on a 40 amp circuit. For all other amperages, complete Steps 2 and 3 for EVSE adjustment.

2. Remove the domed cap from the current-adjustment selector (positioned just above the reset button on the front of the EVSE).
3. Using a small, flat-blade screwdriver, set the current-adjustment selector to the applicable output current-limiting setting."

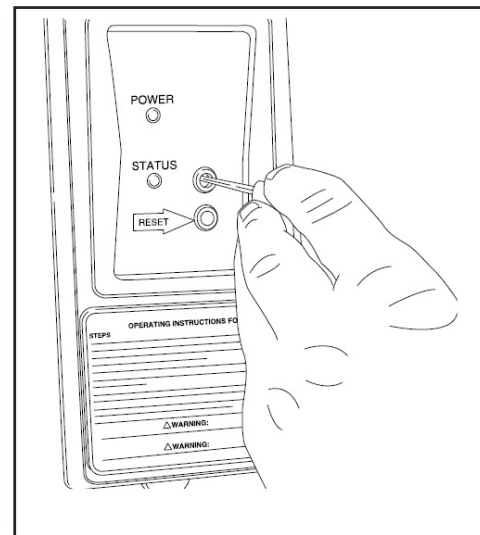

NOTE: Positions 6, 7, 8, 9, 0 are not used (X) and are non-operational. The EVSE will not function under these settings.

⚠ WARNING: The EVSE setting cannot exceed ampacity ratings of field service wires or branch circuit protectors.

⚠ WARNING: See “output” specification label located on the side of the EVSE for maximum amperage setting, per limitations of vehicle cable and coupler.

NOTE: The EVSE must be de-rated to match line service power limitations.

⚠ CAUTION: Use 75°C (600V) approved wire, conductor temperature at 30°C ambient in wet or dry locations.

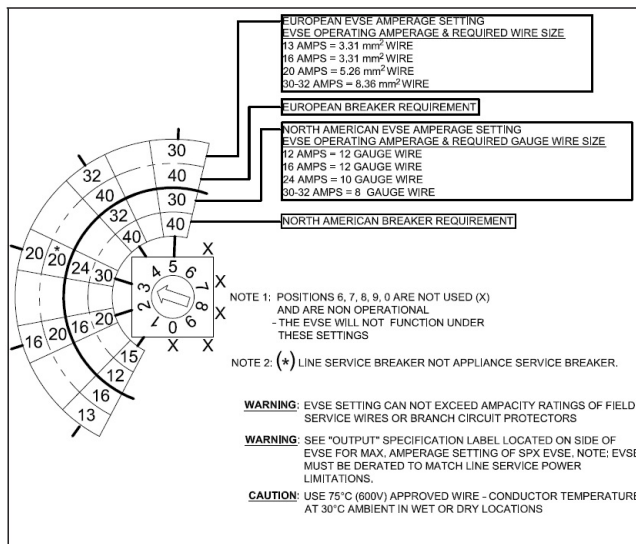

8.0 Standard Installation

1. Lay down the bollard box and remove the banding.
2. Lift the top off the box and remove the bollard from the packaging material.
3. Remove the upper cover from the bollard assembly by removing the cable-management retaining screws (E) on the rear of the bollard.

4. Remove plastic bag containing locating set screw (not shown) from inside bollard.

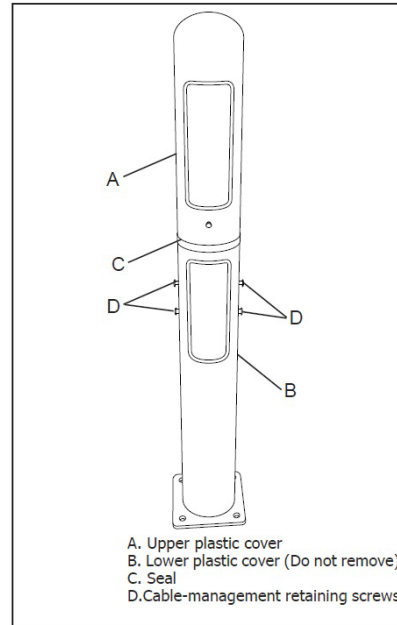

NOTE: The upper and lower plastic bollard covers are a matched set and cannot be used inter-changeably with those from other bollards.

The standard installation design for the Power Xpress Bollard is a bolt-down external plate.

The standard diameter of the bollard is approximately 7 in. The bollard height will vary with the application.

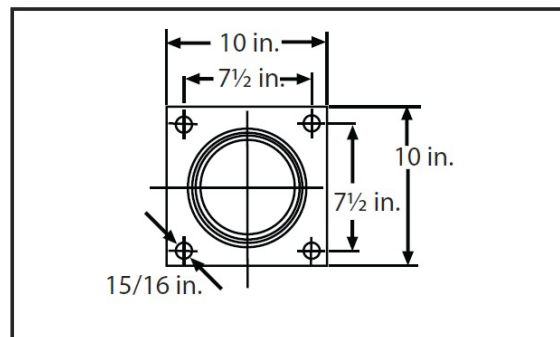
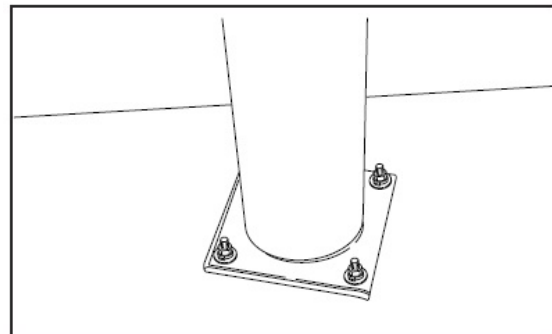

⚠ CAUTION: Read all instructions before installing the EVSE.

⚠ WARNING: Main service power must be off and disconnected before attempting to install the EVSE.

⚠ WARNING: The bollard weighs 20 lb per foot, and the bottom end is significantly heavier than the top end. Take proper precautions and use safe lifting practices when lifting the bollard.

5. Place the bollard where it is to be installed and drill holes.
6. Install the 3/4 in. anchor bolts in accordance with industry standards for the type of mounting being performed.

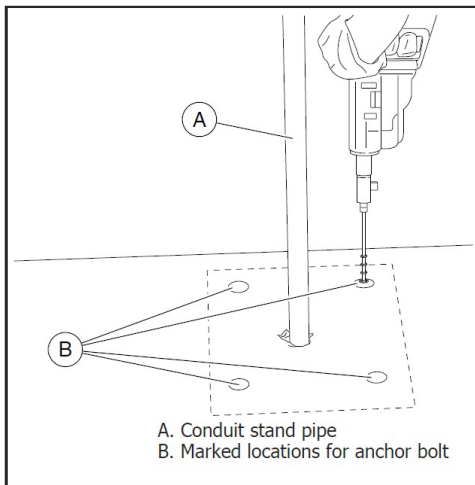

NOTE: Adapters may be used to attach junction box to stand pipe. All adapters and boxes must be suitable for wet locations.

NOTE: Consult national and local codes for approved service codes.

7. Adjust charging cable strain relief to the following locations.
 - Top unit - 7 in. from EVSE
 - Bottom unit - 24 in. from EVSE

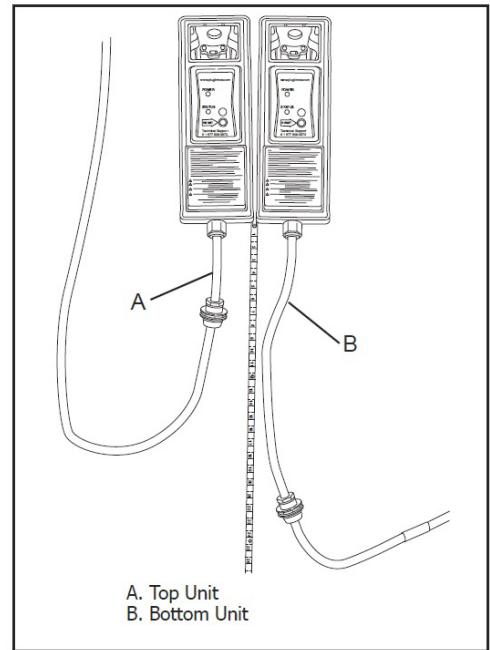

8. Install cable gland in top of wiring chamber.
9. Remove the top plastic cover.
10. Back out fasteners so that they do not extend into the inside of the bollard.
11. Cut 2 lengths of service cord approximately 6.5 ft. and 8.5 ft.
12. Feed cord through the length of the bollard. Excess should extend approximately 14 in. past bollard base.

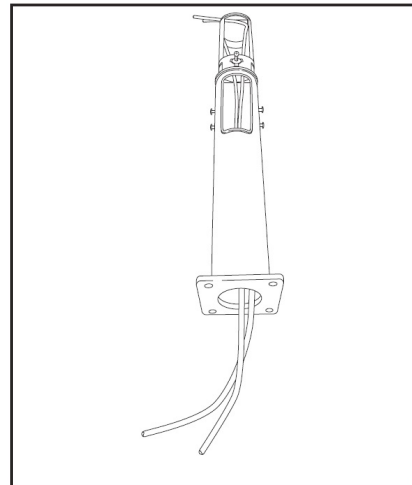

13. Feed the length of the charging cable through the exit hole in the side of the bollard.

NOTE: Fish tape can be used to pass the service cord through the bollard and past the EVSE units.

14. Pass the cord for the top unit past the side of the EVSE and behind the black face.

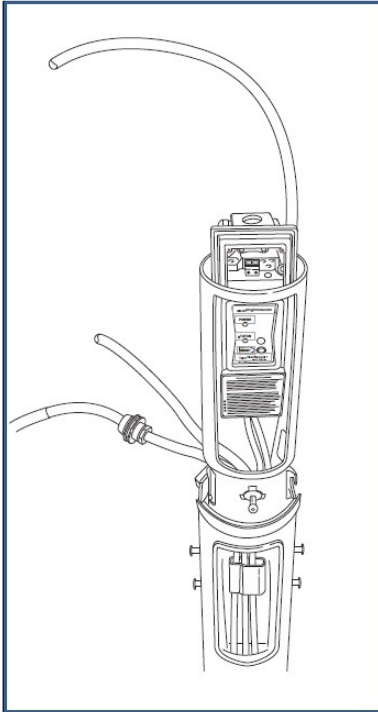

16. Install cord into top wiring chamber of the bottom unit.

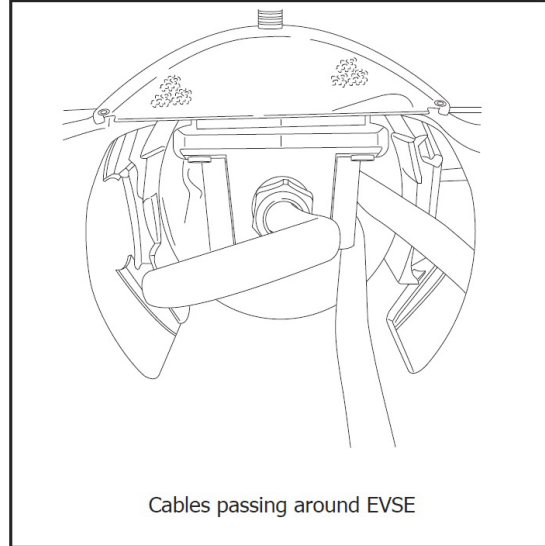

15. Slide bottom unit into mounting position. Take caution not to scrape the front surface of the EVSE against the bollard. Cables and cords will pass by the sides of the EVSE.

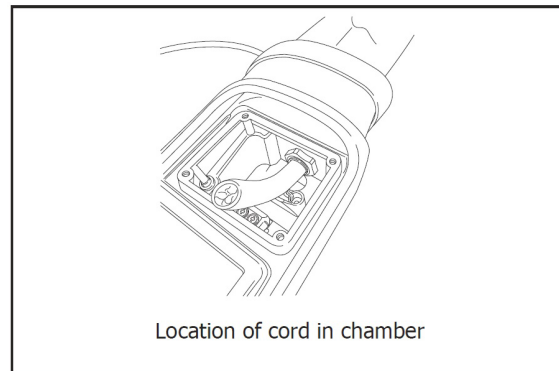
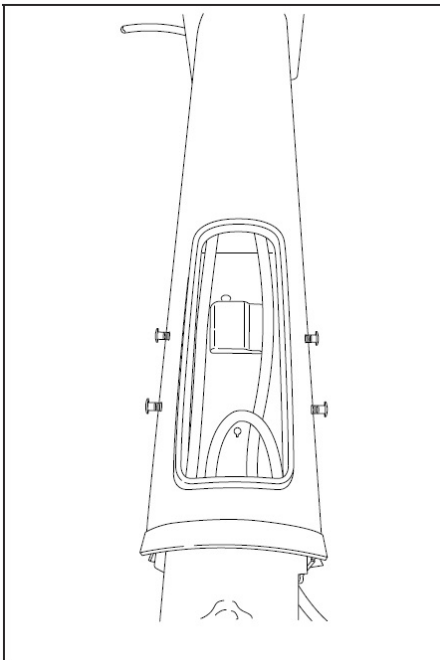

17. Pass the charging cable through the exit hole on the side of the bollard.
18. Feed the cord past the side of the EVSE and slide into position.

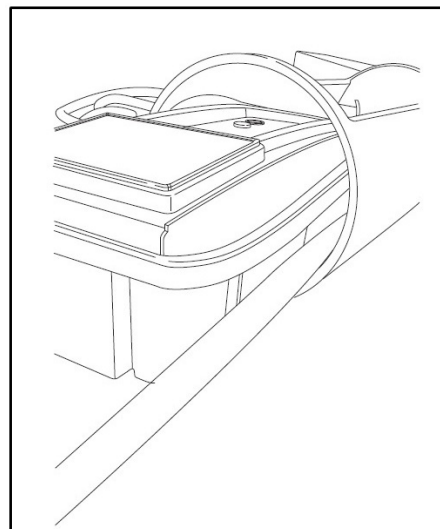

19. Install cord into top wiring chamber of the top unit.

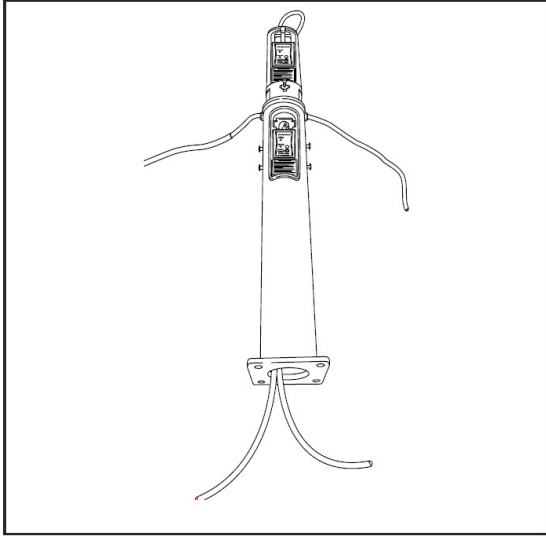

20. Tighten fasteners on the back of the bollard.
 21. While tightening the fasteners guide the EVSE's so that the bottom cover is resting on the ledge of the bollard.
 NOTE: The fasteners will force the EVSE's snugly against the bollard.

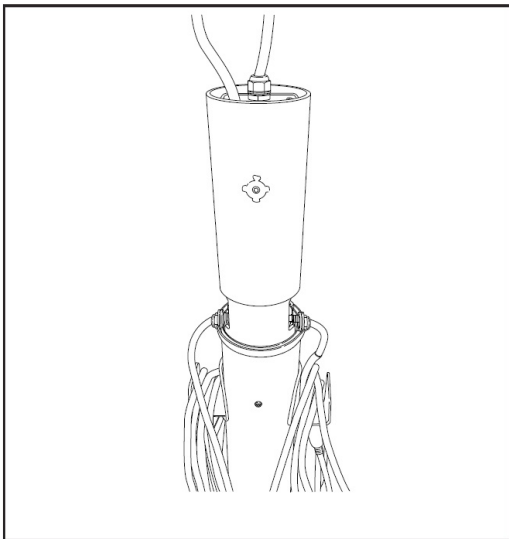

22. Position the strain relief at the bottom of the side slot metal mounting bracket in the steel bollard. Position such that the rubber grommet (D) seats on the opening of the lower plastic bollard cover. Repeat on opposite side.

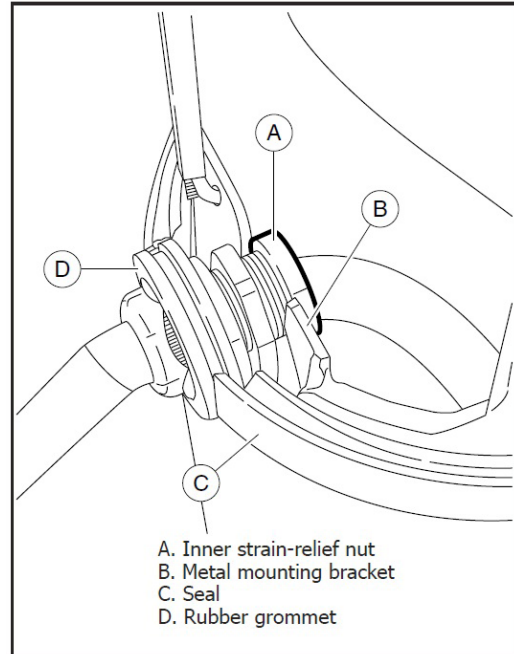

23. Tighten the inner strain-relief nut (A) inside the bollard hand tight. Using expandable pliers, tighten the nut an additional 1/4 turn.

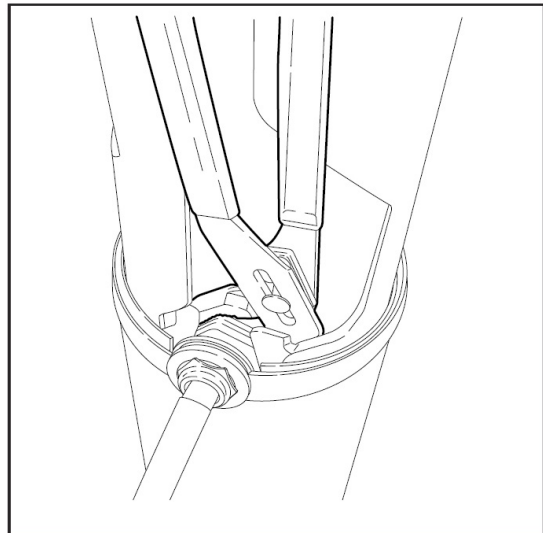

NOTE: Do not overtighten the strain-relief nut. The grommet may pull through.

24. Install cable hooks on the sides of the bollard.

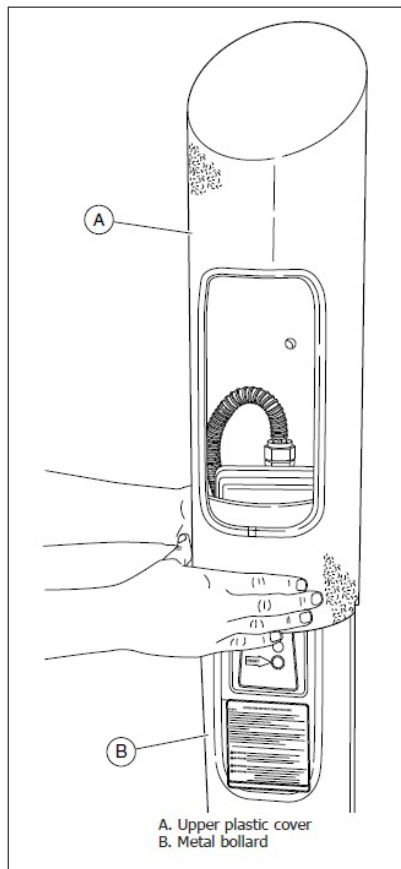
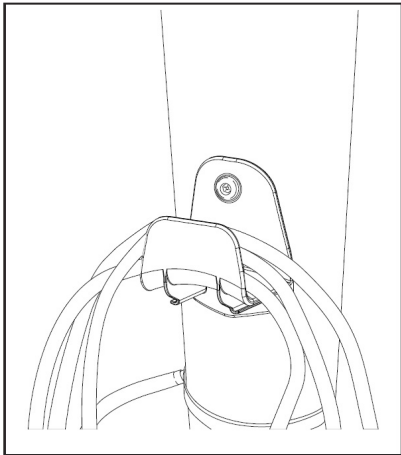

25. Use a small flat-blade screwdriver or similar tool to guide the upper plastic cover into seal.

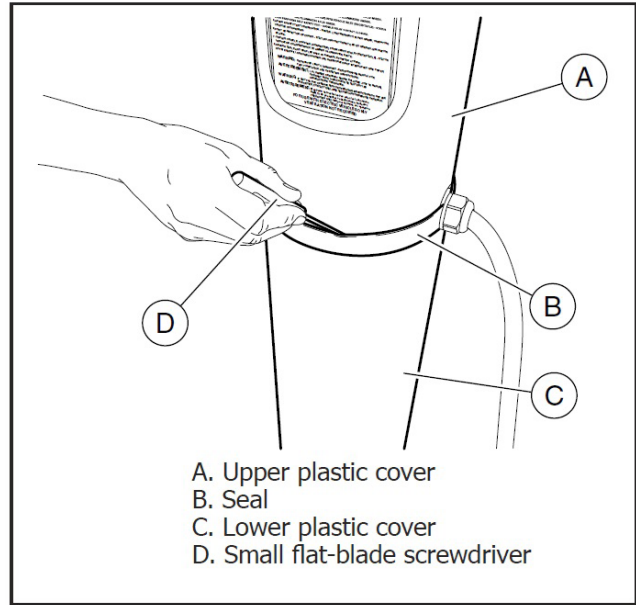

26. While gently pressing down on the upper plastic cover, carefully slide the screwdriver around the bollard to extend the upper lip of the seal over the upper plastic cover. The upper cover may need to be tapped gently to fully seat it in the seal.

⚠ CAUTION: Use care not to cut or damage the seal during this procedure.

- 27. With assistance, move bollard next to the prepared site.
- 28. Feed cords into the junction box and secure cable glands.
- 29. Wire cords to the supply wires and seal the junction box with a cover suitable for wet location.

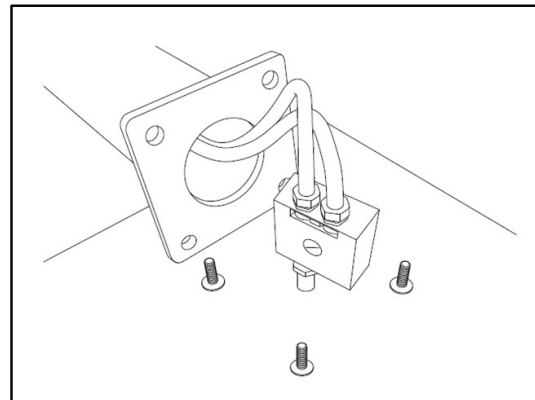

- 30. With assistance, lift bollard onto mounting bolts.
- 31. Level, adjust, and tighten mounting nuts according to anchor manufacturer specification.

32. Loop the cables onto the cable-management holder.

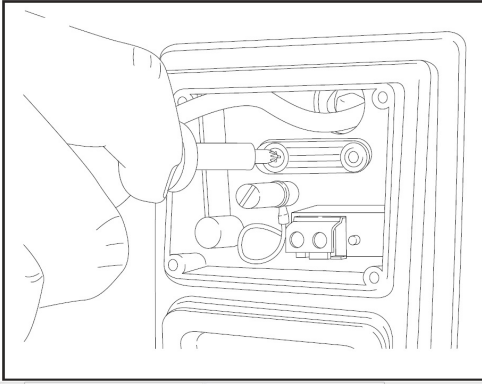

33. Remove the strain-relief assembly from the wiring chamber.

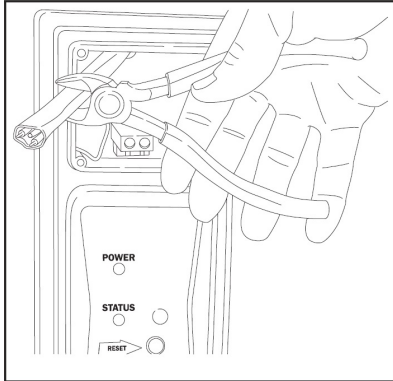

34. Trim the wire to a length sufficient to make the connections to the Charge Station terminal block.

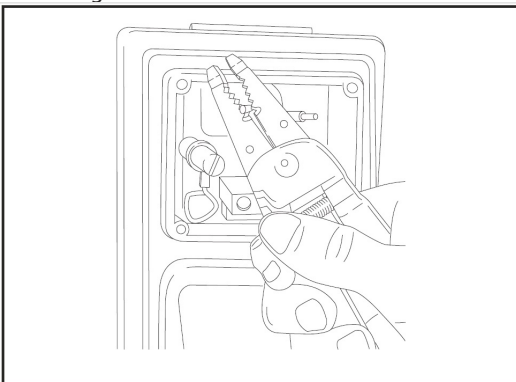

35. Strip back 1 1/4 in. (32 mm) of the wire jacket and 3/8 in. (10 mm) from the ends of the individual conductors.

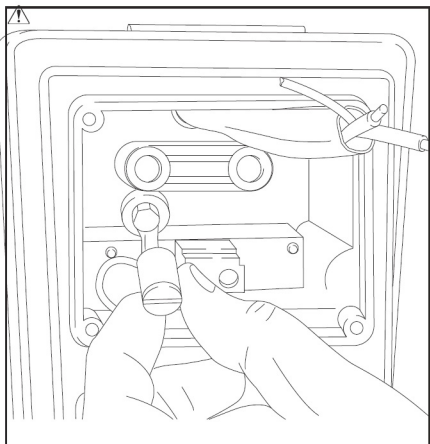

36. Remove threaded ground lug.

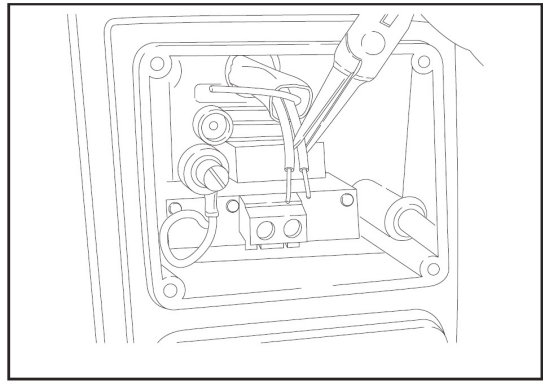

37. Feed the L1 wire into the L1 terminal slot in the wiring chamber.

38. Feed the L2 wire into the L2 terminal slot in the wiring chamber.

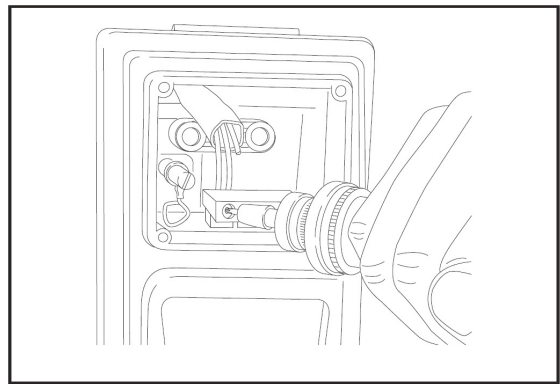

39. Attach safety ground wire through the slot on the ground terminal. Hand-tighten grounding lug.

NOTE: See inside of wiring chamber cover for wiring schematic.

40. Tighten terminal screws to 1.2 Nm (10.62 in-lb).

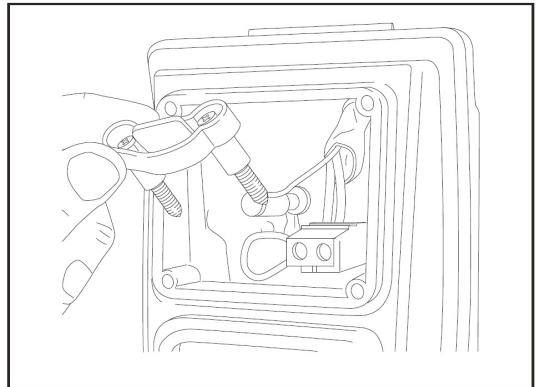

41. Reinstall strain relief.

NOTE: Select appropriate orientation of insert to achieve proper clamping for wire size used.

⚠ CAUTION: Do not overtighten.

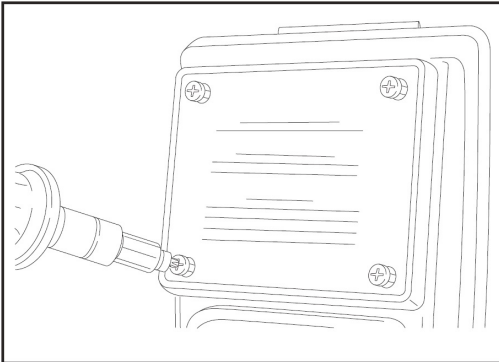

42. Attach the wiring chamber lid with four (4) 3/4 in. (20 mm) square-drive screws.
43. Apply the self-adhesive chamber lid label.





















44. Switch the main circuit breaker to the ON position and verify that the Power LED is illuminated solid green and the Status LED is illuminated solid amber on the EVSE.



45. Place both halves of the plastic base cover over bollard base. Secure with plastic push pins



9.0 Power and Status LED Indications

Power LED	Status LED	Condition
(Off) 	(Off) 	No service supply power
Green solid 	Amber solid 	Charge Station powered; vehicle coupler not connected
Green solid 	Green solid 	Waiting to charge
Green solid 	Green flashing 	Vehicle charging
Green solid 	1–2 red flashes every 2 seconds 	Pilot charging error*
Green solid 	Solid red, then green flash every 2 seconds  	Ground fault detected*
Green solid 	Red flashing 	Ground monitor interrupted*
Green solid 	Red solid 	Operation fault*
Green solid 	(Off) 	Operation fault*

*See "Troubleshooting" for suggested solutions.

-  - No illumination
-  - Solid illumination
-  - Flashing illumination

10.0 Troubleshooting

If there is a charging issue proceed with the following steps. If the issue persists after three attempts call Bosch at 1-877-805-EVSE (3873) for assistance.

Problem Indicated by LED Status	Solution
Pilot charging error	<ol style="list-style-type: none"> 1. Verify supply-side power. The green POWER LED should be on. If green POWER LED is off, locate load center/panel and reset breaker. 2. Press the master clear RESET button on the front panel of the Charge Station to attempt a charge-restart. 3. If the red STATUS LED remains on, disconnect the Charge Station coupler from the vehicle charge port, wait 10 seconds, and reconnect the coupler.
Ground fault detected	<ol style="list-style-type: none"> 1. Disconnect main service power at service panel. 2. Disconnect the Charge Station coupler from the vehicle. 3. Inspect the Charge Station connector and the vehicle charge port verifying both are clean and undamaged. If vehicle charge port needs cleaning, follow manufacturer instructions for cleaning. Clean Charge Station connector with a dry or damp cloth if necessary. 4. Restore main service power. 5. Reconnect the coupler to the vehicle port.
Ground monitor interrupted	<ol style="list-style-type: none"> 1. Disconnect main service power at service panel. 2. Disconnect the Charge Station coupler from the vehicle. 3. Inspect the Charge Station connector and the vehicle charge port verifying both are clean and undamaged. If vehicle charge port needs cleaning, follow manufacturer instructions for cleaning. Clean Charge Station connector with a dry or damp cloth if necessary. 4. Restore main service power. 5. Reconnect the coupler to the vehicle port.
Operation fault	<ol style="list-style-type: none"> 1. Verify supply-side power. The green POWER LED should be on. If green POWER LED is off, locate load center/panel and reset breaker. 2. Press the master clear RESET button on the front panel of the Charge Station to attempt a charge-restart. 3. If the red STATUS LED remains on, disconnect the Charge Station coupler from the vehicle charge port, wait 10 seconds, and reconnect the coupler.

10.1 Ground Fault Circuit Interrupt (GFCI) Tripped

If the Charge Station detects a ground fault, power will be interrupted and the STATUS LED will illuminate (red flash with intermittent green). The Charge Station will attempt to reset automatically and re-attempt charging (see note below on European models). If the fault condition persists after an initial automatic attempt, per the code, the Charge Station waits 15 minutes before a second attempt is made. A total of four attempts will be made to restore vehicle charging. If the charging mode cannot be restored, the STATUS LED will illuminate solid red, and the unit will stay in fault mode.

NOTE: European models—Automatic reset feature after ground fault (STATUS LED will be solid red) does not apply to European models. European standards dictate that user intervention is required by pressing the master clear RESET button on the front of the Charge Station housing. If ground fault condition clears, Charge Station will resume charging.

10.2 Missing Ground

If the Charge Station detects a missing ground connection (rapid red flashing LED), power will be interrupted and the unit will not be capable of charging vehicle until a ground connection has been detected. Disconnect service power (breaker) and disconnect vehicle coupler from vehicle and contact a qualified Bosch technician to validate the presence of a proper ground.

11.0 Limited Warranty

THIS LIMITED WARRANTY IS EXPRESSLY LIMITED TO THE ORIGINAL PURCHASER ("PURCHASER") OF THE BOSCH POWER XPRESS LEVEL 2 CHARGING STATION WITH BOLLARD ("CHARGING STATION"). THE BOLLARD IS THE DECORATIVE PLASTIC CASING, STEEL HOUSING AND BASE COVER.

IMPORTANT: It is the Purchaser's obligation to register the Charging Station with Bosch and failure to do so may delay warranty support. To register a Charging Station online, go to BoschEV Solutions.com or call 1-877-805-3873 for assistance.

Bosch Automotive Service Solutions Inc. ("Bosch") warrants to the Purchaser that the Charging Station will be free from defects in materials and workmanship for the warranty period specified below ("Warranty Period"). This warranty is valid for purchasers located in the U.S.A. and Canada only.

Charging Station excluding Bollard: 3 years

Bollard only: 1 year

ALL WARRANTY CLAIMS MUST BE MADE WITHIN THE WARRANTY PERIOD AND PROOF OF PURCHASE ACCEPTABLE TO BOSCH MUST BE SUPPLIED.

The sole and exclusive remedy for any Charging Station found to be defective is repair or replacement, at the option of Bosch. The warranty covers both parts and factory labor necessary to repair the Charging Station, but does not include any on-site labor costs related to un-installing or reinstalling the repaired or replacement Charging Station. This warranty does not cover cosmetic damage such as scratches and dents, or normal aging. Repair parts and replacement Charging Stations may be either new or reconditioned at Bosch's discretion. Any replacement Charging Stations so furnished will be warranted for the remainder of the original Warranty Period. Should Bosch be unable to repair or replace the Charging Station with a comparable Bosch product of Bosch's choice, Bosch will refund the purchase price of the Charging Station to you.

This warranty does not cover the cost of freight to return the Charging Station to Bosch. This warranty does include freight to ship repair parts and or a replacement Charging Station to the Purchaser, using a shipping carrier of Bosch's choice.

This warranty covers only those defects that arise as a result of normal use of the Charging Station and does not cover Charging Stations subject to improper installation, improper connections with peripherals, external electrical faults, accident, disaster, misuse, abuse, neglect, improper maintenance and care, modification, disassembly, operation outside of the Charging Station specifications or in a manner inconsistent with instructions regarding use. This warranty does not apply if the Charging Station's original identification markings (for example, serial numbers and trademarks) have been defaced, altered or removed. The Charging Station is not certified for plugin applications and any modification to create a plugin application will void this warranty.

The existence of a defect shall be determined by Bosch in accordance with procedures established by Bosch. No one is authorized to make any statement or representation altering the terms of this warranty.

This warranty gives the Purchaser specific legal rights. The Purchaser may also have other rights which vary from state to state. To the extent that this warranty is inconsistent with applicable law, this warranty will be deemed modified to be consistent with such local law.

Disclaimer

TO THE EXTENT PERMITTED BY APPLICABLE LAW AND EXCEPT AS EXPRESSLY PROVIDED IN THE LIMITED WARRANTY, BOSCH MAKES NO WARRANTY WITH RESPECT TO THE CHARGING STATION, WHETHER EXPRESS, IMPLIED, STATUTORY OR OTHERWISE. BOSCH EXPRESSLY DISCLAIMS ALL OTHER WARRANTIES, INCLUDING, BUT NOT LIMITED TO, THE IMPLIED WARRANTIES OF NON-INFRINGEMENT OF THIRD PARTY RIGHTS, MERCHANTABILITY AND FITNESS FOR A PARTICULAR PURPOSE. BOSCH DOES NOT WARRANT UNINTERRUPTED OR ERROR FREE OPERATION OF THE CHARGING STATION.

Limitation of Liability

TO THE FULLEST EXTENT PERMITTED BY APPLICABLE LAW, IN NO EVENT SHALL BOSCH, ITS AFFILIATES OR ITS SUPPLIERS BE LIABLE FOR ANY, INDIRECT, SPECIAL, INCIDENTAL, OR CONSEQUENTIAL DAMAGES, WHETHER BASED ON CONTRACT, TORT, OR ANY OTHER LEGAL THEORY EVEN IF BOSCH AND ITS SUPPLIERS HAVE BEEN ADVISED OF THE POSSIBILITY OF SUCH DAMAGES.

Some states do not allow the exclusion or limitation of incidental or consequential damages for some products, so the limitations or exclusions contained herein may not apply.

To Obtain Warranty Service

To obtain warranty service during the Warranty Period, the Purchaser may contact Bosch Technical Support Services (TSS) at 1-877-805-3873 or email to oetech@service-solutions.com for assistance. A Bosch TSS agent will troubleshoot the Charging Station and determine if it has a defect, and if it is covered under this warranty.

In connection with a warranty inquiry, you will be asked for each of the following:

1. Your name and address;
2. A detailed description of the problem you are experiencing with the Charging Station;
3. The model number and serial number of the Charging Station;

4. Proof of purchase; and
5. Return Shipping information.

If Bosch confirms a defect covered under this warranty, you will:

- Obtain a Return Goods Authorization Number (RGA#) number from Bosch;
- Directed to ship the Charging Station, at your expense, in accordance with the instructions provided by Bosch, in either its original package or packaging providing the Charging Station with a degree of protection equivalent to that of the original packaging, to Bosch at the address so instructed at that time.
- You agree to obtain adequate insurance to cover loss or damage to the Charging Station during shipment and you understand prior to receipt by Bosch, you assume risk of any loss or damage to the Charging Station.
- If the Charging Station is covered under this warranty, Bosch will either repair or replace the defective Charging Station at no charge to you and ship the repaired or replaced Charging Station back to you at Bosch's expense, using a carrier of Bosch's choice.
- Any Charging Station that is found by Bosch to be out-of-warranty or otherwise ineligible for warranty service will be repaired or replaced upon your approval and payment of Bosch's standard charges.
- Bosch is not responsible for any unauthorized shipments to Bosch, and under no obligation to return the Charging Station, at its expense. If you do not contact Bosch within five (5) business days of its delivery, Bosch will dispose of the shipment in a manner of its choice without any liability to you. Any damage incurred returning an unauthorized shipment back to you is not Bosch's responsibility.

This warranty is not transferable to subsequent owners of the Charging Station. No attempt to alter, modify, or amend this warranty shall be effective unless authorized in writing by an officer of Bosch. This warranty shall be governed by and construed in accordance with the laws of the State of Michigan U.S.A., exclusive of its conflict of laws principles. The U.N. Convention on Contracts for the International Sale of Goods shall not apply. Bosch reserves the right to amend this warranty policy as required.

Bosch
Automotive Service Solutions Inc.

28635 Mound Road
Warren, MI 48092 USA
Phone: (877) 805-EVSE (3873)

www.pluginnow.com