

ESSE

ESSE 1

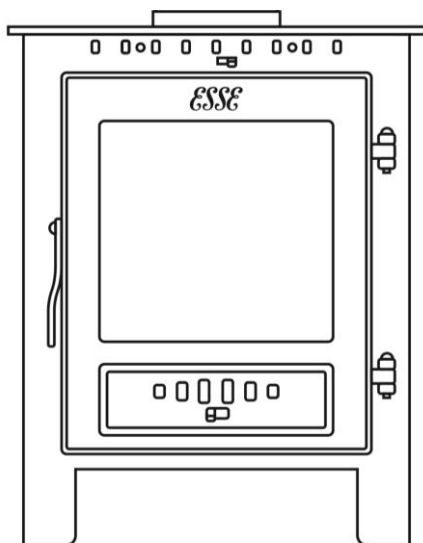

Smoke Exempt Wood Burning Stove

INSTALLATION & USER INSTRUCTIONS

(TO BE LEFT WITH THE CUSTOMER)



CONTENTS

General Safety Notes	Page 2	Commissioning Checklist	Page 13
Installation instructions	Page 3	Operating Instructions	Page 15
Chimney & Flue	Page 4	Wood Burning	Page 16
Flue Draught	Page 6	Solid Fuel Burning	Page 20
Flue Stabiliser	Page 7	Technical Information	Page 23
Dimensions & Clearances	Page 7	Maintenance	Page 25
Installing the Stove	Page 9	Guarantee	Page 26

GENERAL SAFETY NOTES

- Properly installed, operated and maintained, this appliance will not emit fumes into the dwelling. However occasional fumes from de-ashing and re-fuelling may occur. Persistent fume emission is potentially dangerous and must not be tolerated. If fume emission does persist, open doors and windows to ventilate the room. Let the fire burn out or eject and safely dispose of fuel from the appliance. Once the fire is cold, check the flue and chimney for blockages and clean if required. Do not attempt to relight the fire until the cause of the fume emission has been identified and corrected. Seek expert advice if necessary.
- Do not fit an extractor fan in the same room as the appliance.
- It is important that flue ways are cleaned frequently and the chimney swept regularly. Also the stove must be maintained in good mechanical order. Regular sweeping means at least once a year for smokeless fuel and a minimum of twice a year for other fuels.
- If the chimney was previously used for an open fire, it is possible that the higher flue gas temperatures generated by the stove may loosen deposits that were firmly adhering to the inner surface of the chimney and cause blockage of the fluepipe. We recommend that in such a situation a second sweeping of the chimney should be carried out within one month of regular use of the stove after installation. Also, lock or remove any existing dampers in the flueway.
- Should it be likely that children, aged or infirm people approach the fire, then a fireguard should be fitted.
- Avoid the use of aerosol sprays in the vicinity of the stove when it is in operation.
- This appliance must be installed as per these instructions and regulations complied with. No modifications or alterations of any kind are permitted.

CLEAN AIR ACT 1993 AND SMOKE CONTROL AREAS

Under the Clean Air Act local authorities may declare the whole or part of the district of the authority to be a smoke control area. It is an offence to emit smoke from a chimney of a building, from a furnace or from any fixed boiler if located in a designated smoke control area. It is also an offence to acquire an "unauthorised fuel" for use within a smoke control area unless it is used in an "exempt" appliance ("exempted" from the controls which generally apply in the smoke control area).

The Secretary of State for Environment, Food and Rural Affairs has powers under the Act to authorise smokeless fuels or exempt appliances for use in smoke control areas in England. In Scotland and Wales this power rests with Ministers in the devolved administrations for those countries. Separate legislation, the Clean Air (Northern Ireland) Order 1981, applies in Northern Ireland. Therefore it is a requirement that fuels burnt or obtained for use in smoke control areas have been "authorised" in Regulations and that appliances used to burn solid fuel in those areas (other than "authorised" fuels) have been exempted by an Order made and signed by the Secretary of State or Minister in the devolved administrations.

The ESSE One-SE has been recommended as suitable for use in smoke control areas when burning dry wood logs in accordance with these instructions. Peat and other unauthorised fuels must not be burnt in this appliance in smoke control areas.

Further information on the requirements of the Clean Air Act can be found here: <http://smokecontrol.defra.gov.uk/>

Your local authority is responsible for implementing the Clean Air Act 1993 including designation and supervision of smoke.

INSTALLATION INSTRUCTIONS

- The installer has a responsibility under the Health and Safety at Work Act 1974 to provide for the safety of persons carrying out the installation.
- Attention is drawn to the fact that fire cement is caustic and hands must be washed thoroughly after use.
- The appliance is heavy and care must be taken during handling.
- Although the appliance does not contain asbestos products, it is possible that asbestos may be disturbed in existing installations and every precaution must be taken.
- These instructions give a guide for the installation of the appliance but in no way absolves the installer from responsibilities to conform to British Standards, in particular BS8303 and BS EN 15287:2007, relating to the installation of solid fuel appliances.
- All local regulations, including those referring to National and European standards need to be complied with when installing the appliance.
- Permanent ventilation may be required in accordance with the guidelines given in Approved Document J of the Building Regulations.

- It is essential that the fire has adequate air supply for combustion and ventilation. Apertures provided for this purpose shall not be restricted.

CO Alarms

Building regulations require that whenever a new or replacement fixed solid fuel or wood/biomass appliance is installed in a dwelling, a carbon monoxide (CO) alarm must be fitted in the same room as the appliance, in accordance with BS EN 50292:2002. The installation of an alarm must not be considered a substitute for either installing the appliance correctly, or ensuring regular servicing and maintenance of the appliance and chimney system.

CHIMNEY& FLUE

The successful operation of this appliance relies on the adequate performance of the chimney to which it is connected.



WARNING

This Appliance is not suitable for installations in a shared flue system.

The chimney must:

- Have an internal cross section of no less than 320cm² (Ø200mm). If a flue liner is used it should be 125mm diameter (5") and suitable for solid fuel.
- Be a minimum 4.5m high from hearth level to pot.
- Be terminated at least 1m above roof level so that the chimney does not terminate in a pressure zone (see Fig. 2).
- Be free from cracks, severe bends, voids and obstructions.
- Be connected to this one appliance only.
- New chimneys must be tested in accordance with HETAS requirements.
- If the stove is installed as a free standing appliance, it should not support any part of the chimney.
- Voids in the chimney should be avoided, as these will prevent a steady flue draught.
- The stove flue pipe should pass beyond the narrowing of the chimney (see Fig. 1).
- Consideration should be given to falling soot. For rear outlet stoves it may be necessary to provide a soot catchment area in the flue pipe so that soot does not settle in the path of the flue gases. The optional rear flue box attachment available from ESSE has a detachable base that allows for soot to be removed (See Fig. 1).
- A flue/chimney access point may also be required so that the state of the chimney can be checked and any fallen soot removed.
- External flues must be insulated to prevent heat loss.

Fig.1 – Ideal Flue Connections (Flue box available from www.esse.com)

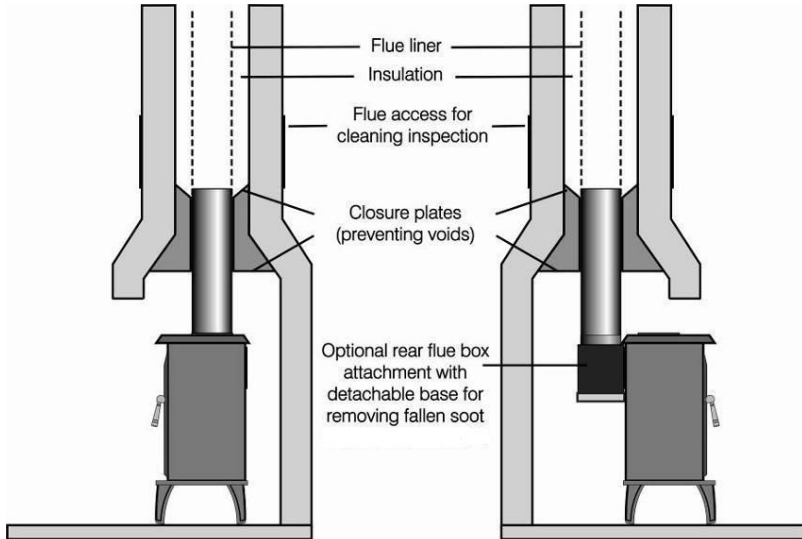
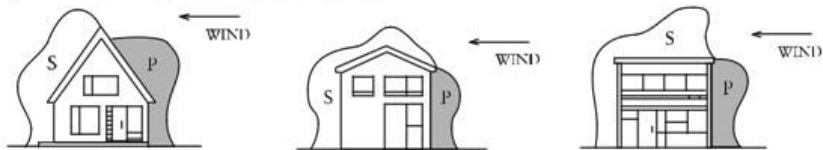
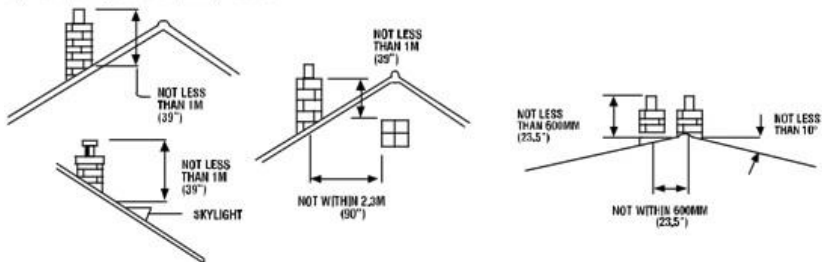

Fig.2 – Chimney and Flue Performance

1) Pressure and suction zones created by wind



2) The position of chimney outlets



3) Potential causes of down draught



FLUE DRAUGHT

The chimney can be checked, before the stove is installed, with a smoke match. If the chimney doesn't pull the smoke it may suggest the chimney needs attention (see the Flue Diagnosis Table, below).



NOTE

This test is only a guide as an apparently poor flue may improve once the stove is installed, lit and the flue is warmed. If, once the stove is installed, there is any doubt that the chimney is providing an adequate draught; a flue draught reading can be taken with the stove lit. Two flue draught readings should be taken, one with the stove at minimum rate and one at maximum rate.

MEASUREMENTS

The flue draught test hole is located on the right hand side of the stove at the back near the top. Remove the screw to allow reading to be taken, replace the screw once readings are complete.

MINIMUM

The stove should be lit and allowed to warm the flue thoroughly. The air controls can then be closed so that the stove burns on a low setting. Allow the burning rate to become steady. The flue draught reading should now be taken with both air controls fully closed.

MAXIMUM

The primary air intake can now be opened to allow the stove to burn at maximum rate. Give the stove some time for the burning rate to become steady and then close the primary air control, make sure the secondary air control is fully open and take a flue draught reading immediately. Ideally, the flue draught reading should range between 1mm wg (10 Pa) and 2.5mm wg (25 Pa). Any readings significantly outside this range may indicate the need for remedial action.

Low flue draught symptoms: difficult to light and smoke coming into the room.

CAUSE	REMEDY
Cold chimney	<i>Line the chimney</i>
Chimney too short	<i>Extend the chimney</i>
Down draught	<i>Relocate/extend chimney terminal. Fit an anti-down draught cowl</i>
Chimney diameter too large	<i>Line the chimney</i>
Chimney obstruction	<i>Clear/sweep the chimney</i>
Restricted air supply	<i>Check for competing draughts (other chimneys, extractor hoods/fans) - Fit an air vent if the room is sealed</i>

High flue draught symptoms: fire difficult to control, fuel will not last, stove too hot, stove damage, chimney fire.

CAUSE	REMEDY
External wind conditions combined with chimney terminal	<i>Fit stabiliser cowl Fit flue draught stabiliser</i>

FLUE STABILISER

A flue stabiliser can be fitted to reduce the draught through the stove if the flue draught is too high. The flue stabiliser should be:

- Fitted in the same room as the stove.
- The same size as the flue pipe.
- Fitted no closer than 700mm to the flue outlet of the appliance.

DIMENSIONS & CLEARANCES

Fig.3a – ESSE 1 Dimensions

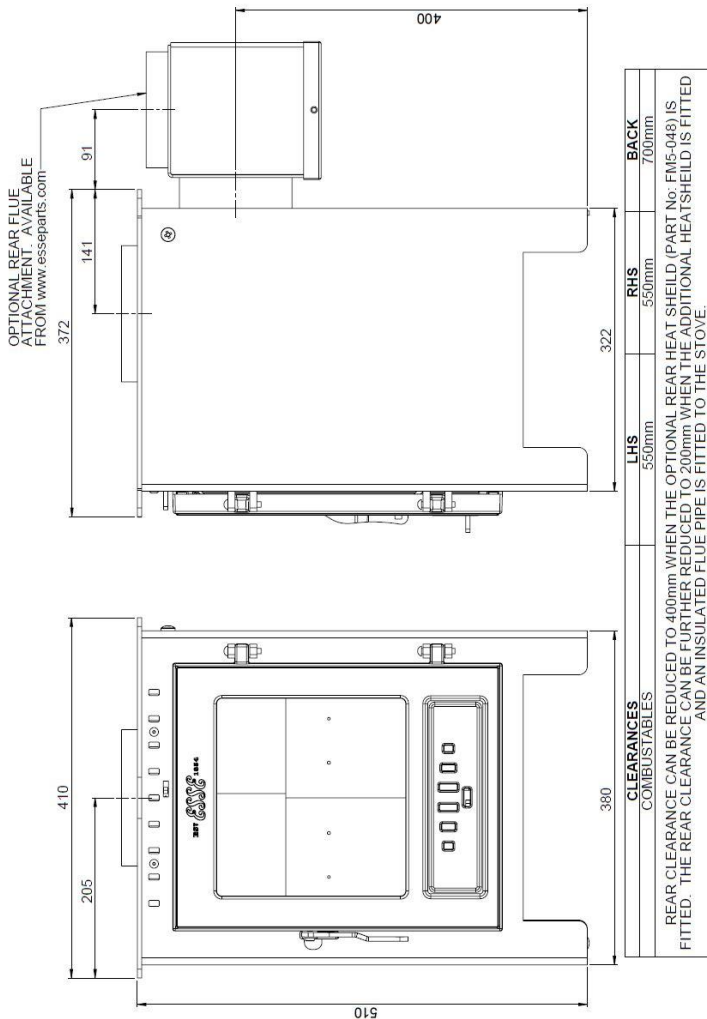
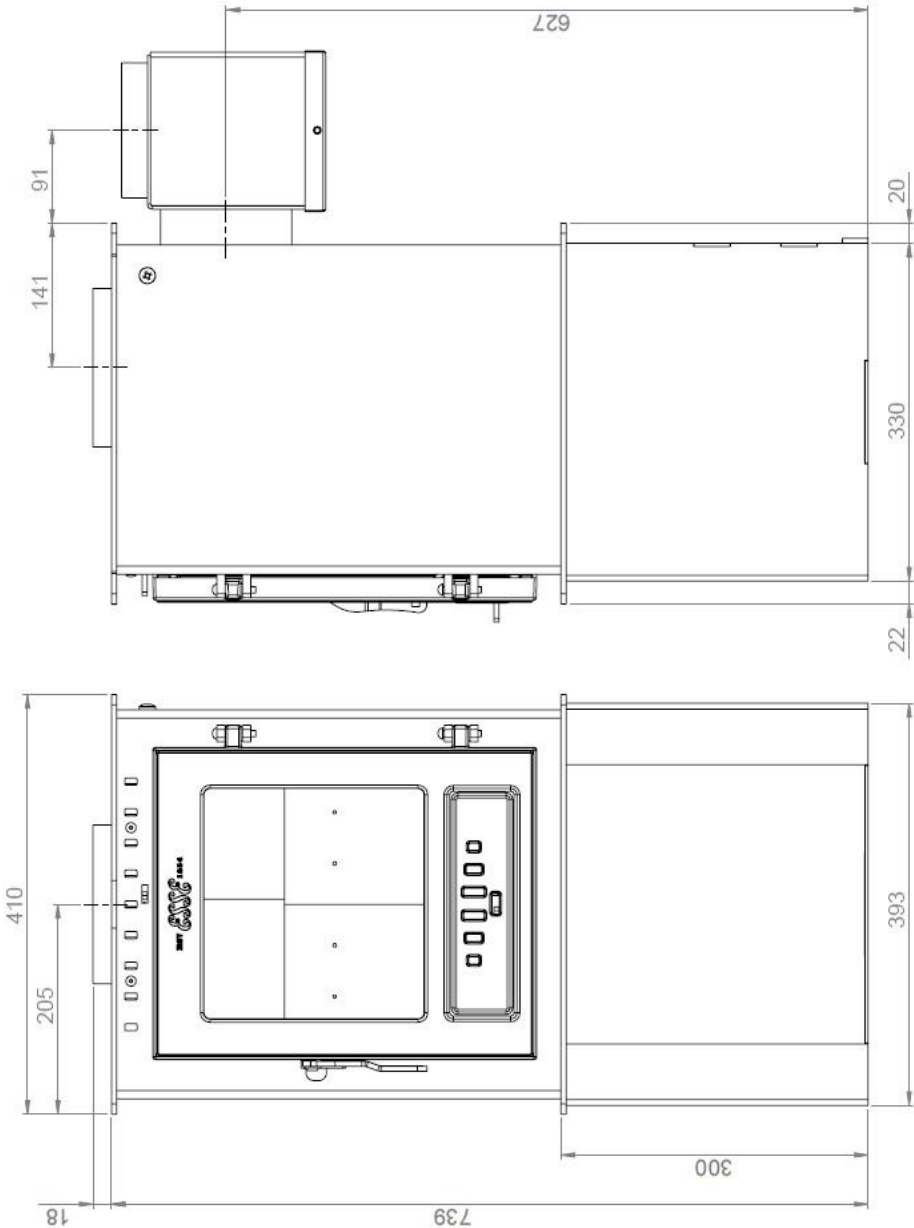

Fig.3b – ESSE 1 with Log Box Dimensions



INSTALLING THE STOVE

POSITIONING

The overall dimensions of the stove are shown in Fig. 3 along with a table that indicates recommended distances between the stove and surrounding combustible materials. As a rule, any surrounding combustible material should not exceed 80°C. There should be sufficient space around the stove for service work.

HEARTH

The construction of the hearth must conform to Building Regulations, must be firm, non-combustible and capable of supporting the stove. (Refer to Building Regulations Document J).

FLUE CONNECTION

The flue pipe used to connect the stove to the chimney is 125mm (5") in diameter. The stove is supplied ready for top flue connection. To change to rear connection, the flue blanking plug supplied with the stove is used to block the top flue outlet. The blanking plug in the rear flue connection must then be removed (to access the bolts attaching the rear flue connection, the convector panel must first be removed) - see Fig. 4. A rear flue box attachment is also available from www.esse.com that allows the stove to be installed further out of any building recess. Fig. 1 shows suitable flue connections.

IMPORTANT INSTALLATION NOTES

1. The installation must allow for adequate chimney sweeping.
2. Avoid using bends greater than 45° to the vertical. All flue pipe sections should be as close to vertical as possible.
3. All joints in the flue system must be effectively sealed.
4. All flue sockets must face upwards.
5. Check the appliance for soundness of seals between castings and main components and that all supplied parts and fittings are correctly fitted.

On completing the installation, check that all the internal components of the stove are positioned correctly.

Check - Baffle, vermiculite bricks, and, ash pan and grate if needed.



NOTE

Leave the appliance operational and explain the operation of the stove to the customer. Leave all instructions and operating tools with the customer.

Fig. 4 – Arranging the flue for top or rear outlet.

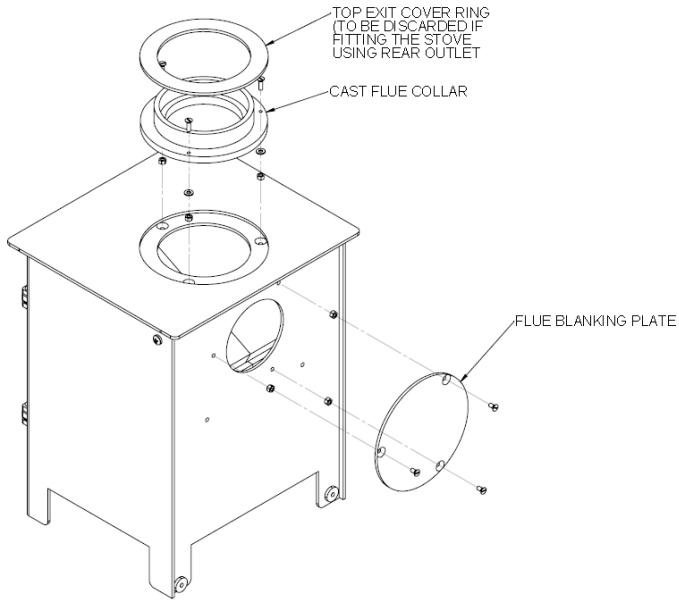
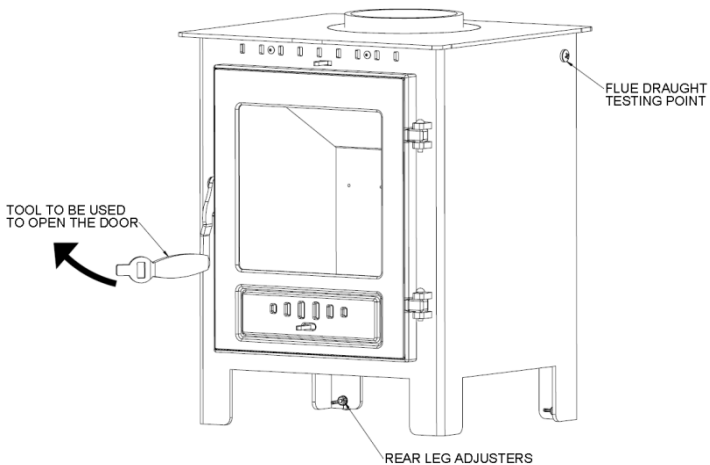

Fig. 5 – Stove features



When positioning the stove the two rear legs are fitted with adjustment plates to accommodate for hearth variations.

With the stove in place, loosen the required wing nut and slide the adjustment plate to the required position and tighten up the wing nut.

INSTALLING THE ADDITIONAL REAR HEAT SHIELD

The additional heat shield kit (Part No: FM5-048) should be fitted to the stove prior to connecting the flue pipe.

1. Remove the 4 screws labelled (A).

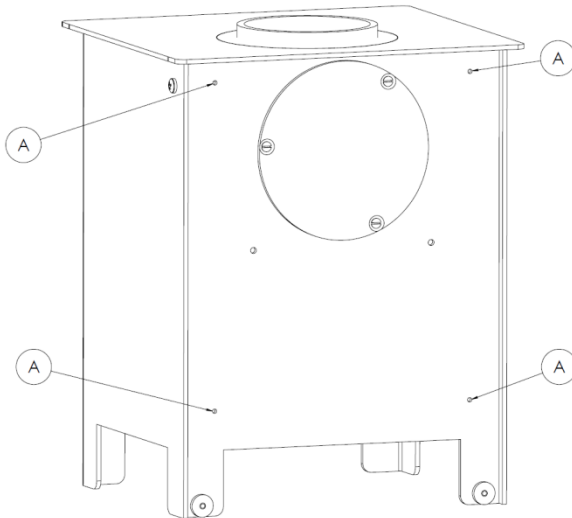

2. Screw in the threaded spacer bars, labelled (B)

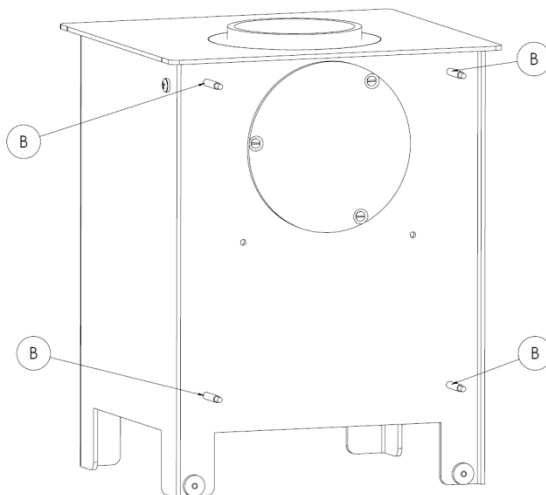

3. Fit the additional heat shield labelled (C) and fasten with the nuts provided. Remember to refit the Stove data label on the rear spacer labelled (D).

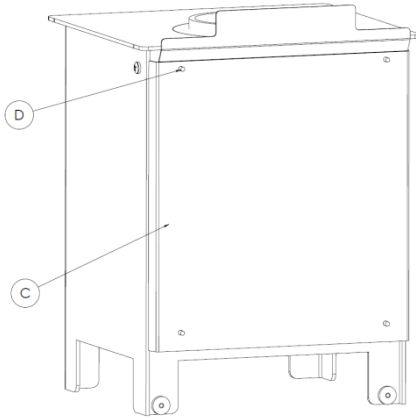

Installing the optional log box

1. Remove the levelling discs from the back of the stove and fit to the back of the log box.
2. The stove can now be lifted and fitted into the slots on the top of the log box.
3. The stove can now be fitted as normal.

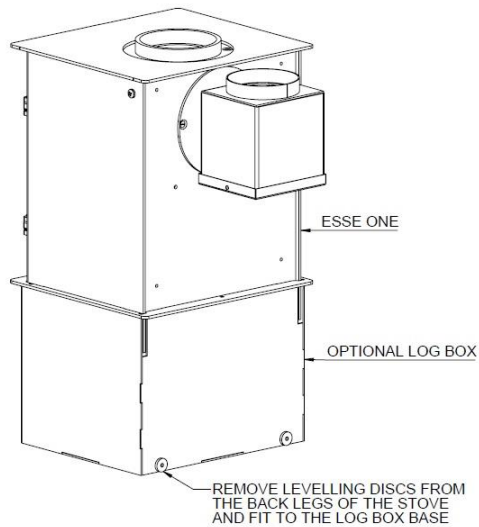

COMMISSIONING CHECKLIST

To assist with any potential guarantee claim please complete the following information:-
To be completed by the installer.

Dealer the appliance was purchased from:

Name:

Address:

Telephone No:

ESSENTIAL information:

Date Installed

Model Description:

Serial No:

Installation Engineer:

Company Name:

Address:

Telephone No:

Commissioning Checks – to be completed and signed:

Is the flue system correct for this appliance?	Yes	<input type="checkbox"/>	No	<input type="checkbox"/>
Flue swept and checked for soundness?	Yes	<input type="checkbox"/>	No	<input type="checkbox"/>
Smoke test completed on installed appliance?	Yes	<input type="checkbox"/>	No	<input type="checkbox"/>
Spillage test complete?	Yes	<input type="checkbox"/>	No	<input type="checkbox"/>
Has the use of the appliance, operation and controls been explained?	Yes	<input type="checkbox"/>	No	<input type="checkbox"/>
Clearance to combustible materials checked?	Yes	<input type="checkbox"/>	No	<input type="checkbox"/>
Instruction book handed to the customer?	Yes	<input type="checkbox"/>	No	<input type="checkbox"/>
CO Alarm fitted?	Yes	<input type="checkbox"/>	No	<input type="checkbox"/>

Signature:..... Print Name:.....

Product Fiche



Energy Labelling Directive - (EU) 2015/1187 for Solid Fuel Boilers and Packages of Solid Fuel Boilers, Supplementary Heaters, Temperature Controls and Solar Devices

Manufacturer Name:

ESSE Engineering Ltd.

Model Name:

ESSE 1

Energy Efficiency Class:

A+

Nominal Heat Output to Room:

5.0

Nominal Heat Output to Water:

0.0

Seasonal Space Efficiency:

108.7

Net Efficiency:

81.9

Note: The product fiche can cover a number of solid fuel boiler models supplied by the same manufacturer. Please use additional cells containing the information above for more than 1 appliance.

Comments/Installation/Handover Instruction:

--

OPERATING INSTRUCTIONS



WARNING

Over firing will damage your stove.
To maintain peak efficiency, your stove should burn approximately 1.0kg of well-seasoned wood per hour.



WARNING

Your stove should not be used as an incinerator and only recommended fuels shall be used.



WARNING

Parts of the appliance, especially the external surfaces, will be hot to touch when in operation and due care will need to be taken



WARNING

It is essential that the fire has adequate air supply for combustion and ventilation. Apertures provided for this purpose shall not be restricted.



WARNING

Always use stove tool when adjusting controls and opening or closing the door

Additional loose parts supplied inside your stove include:

- A Stove tool – For adjusting the air controls and operating the door handle.

Fig. 6 – Stove Controls

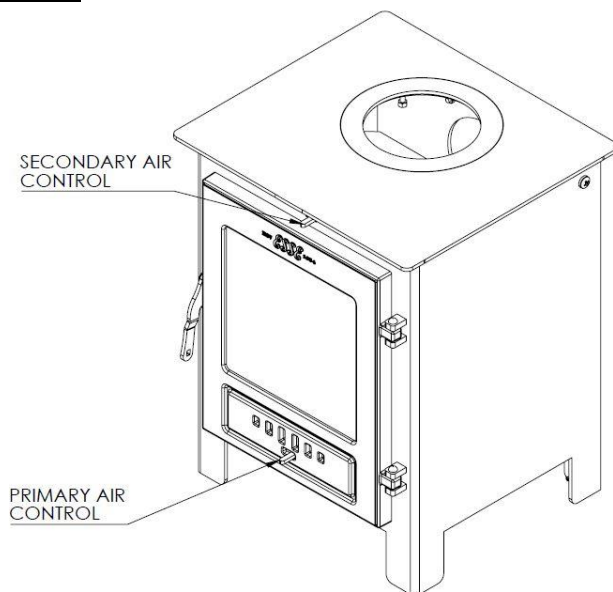

RE-FUELLING ON TO A LOW FIRE BED

When adding new fuel to the stove, if there is insufficient burning fuel remaining in the fire bed to light the additional fuel, you may experience excessive smoking, as the new material struggles to light. This should be avoided by using additional kindling, if required.

FUEL OVERLOADING

Burning excessive amounts of fuel over a sustained period can damage your stove. With this in mind, a maximum of 1kg of fuel should be added to the stove each hour.

OPERATION WITH DOOR LEFT OPEN

Operation with the door open can cause excess smoke. The appliance must not be operated with the appliance door left open except as directed in the instructions.

DAMPERS LEFT OPEN

You may experience excessive smoking if too much air is allowed into the stove throughout its use. With this in mind, the door, primary and secondary air controllers and flue dampers should only be left open as directed within these instructions.

WOOD BURNING

LIGHTING & CONTROLLING THE FIRE

Before lighting the fire ensure that all vermiculite bricks are in the correct position.

Close the primary air control and ensure the secondary air control is in the open position by moving the secondary control to the right. Open the fire door and lay two logs along the base of the fire box, in a left to right direction, forming a space between them.

Fig.7-Logs laid in fire box.



Place a firelighter in the space and surround with a small amount of kindling. Lay a third log over the top of the space perpendicular to the other logs.

Fig.8-Final log in position.



When you are ready to light the fire, simply light the firelighter.

Once the fire has been lit, leave the door partially open to allow additional airflow until the fire has become established. Once the fire is established, the door should be fully closed, and the level of the primary and secondary air controllers should be carefully reduced, to achieve the desired effect



When the stove is running ALL HANDLES become hot and the operating tool or glove provided should be used to open or close the door, or adjust the air controllers.

The burning rate of the stove can now be regulated by the rate at which fuel is added and use of the air control. In order to achieve nominal heat output, the maximum amount of fuel to be loaded during normal operation is 1kg per hour.



This appliance is not an incinerator and only dry well seasoned wood or approved solid fuels should be used. Burning other solid fuels such as treated wood is not possible.

When refuelling the stove it is recommended that the logs are placed running side to side as in Fig. 7 as this leads to the cleanest combustion. Before lighting a full fire in the stove for the first time it is recommended that 3 smaller fires are lit first to ensure that any moisture is driven out.

For the cleanest burn using wood it is recommended that the primary air control is fully closed and the secondary air control is opened so the control is centred in its travel.



Wood burns most efficiently when the air for combustion is supplied from above the fire bed rather than below. The air supplied above the fire bed provides the oxygen necessary for the volatile gases (smoke), given off by the wood as it heats, to combust. This ensures that the gases are burnt and used to heat the stove instead of being wasted up the chimney or condensing and forming tarry deposits inside the stove, in the flue or on the stove glass. Running the stove with the primary air control open and the secondary air control closed, will provide oxygen for the wood to burn on the fire bed but will not provide air for the volatile gases above the fire bed to combust resulting in a smoky inefficient fire.

ASH REMOVAL

Only remove small amounts of ash from the firebox. When de-ashing, leave 30-40mm depth of ash in the bottom of the firebox for the best performance.

CORRECT RUNNING TEMPERATURES FOR BURNING

To get the best results from your stove it is recommended that a wood stove thermometer (available from your stove dealer) be fitted to the flue pipe above the stove, at eye level if possible. The figures below show the recommended temperature of the flue gases:

115°C – 245°C

The flue gases should be in this temperature band for the safest, most efficient and most economical operation of your stove.

Below 115°C

This is below the condensation point of wood gases and may cause the build-up of tar in the chimney, dirty the stove glass and result in the inefficient burning of the fuel.

Above 245°C

Too hot. Heat will be wasted up the chimney. Excess heat may damage the stove or ignite any existing accumulation of tar resulting in a chimney fire.

EXTENDED BURNING

Loading a large amount of wood into the stove all at once will reduce the temperature inside the stove. If the temperature is too low, the gases given off from the wood will be too low to combust resulting in a lot of smoke covering the inside of the stove, including the glass, with soot. To combat this problem it is a good idea to increase the temperature of the stove before loading by further opening the air inlets. Load the wood and leave the air controls open until the moisture is driven out of the wood and the stove is back up to an efficient operating temperature. The air inlets can then be reduced to hold the temperature of the stove. Loading the stove little and often will help keep the stove temperature steady. When loading wood, make sure that the end grain of the wood in the stove is pointing away from the glass, otherwise the moisture and gases coming from the end grain of the wood will dirty the glass.

TYPES OF WOOD FOR FUEL

For best results, use well-seasoned hardwood such as Oak, Ash or Beech. Allow wood to dry out under cover in well-ventilated conditions for at least twelve months. As a rough guide wood is ready for burning when radial cracks appear in the end of logs. Properly dry wood means it should have a moisture content of between 15%-20% which can only be accurately measured using a moisture meter. Burning wood that is not seasoned will result in tar being deposited in the stove, on the glass and in the flueways. This build-up of tar is a hazard and if it ignites may cause a chimney fire. Resinous softwood burns well and gives a high output for short periods but is not as efficient and does not last as long as hardwood.

RE-FUELLING

Adding a 'little fuel often' is the best re-fuelling method to keep smoke to a minimum. Our tests have shown that burning logs not longer than 20cm and with a width or diameter of no more than 12cm will produce the optimum smoke free performance.

SOLID MINERAL FUEL BURNING

The Esse One-SE comes set up as a Wood Burning only stove as standard. It can be converted to burn solid mineral fuel with the purchase of the solid mineral fuel burning kit (Part No: ESSE 1 MF KIT). See instructions below to fit the conversion kit.

- 1 Ensure that the stove is cold and not lit.
Open the door and remove all the ash, any unburnt material and the vermiculite bricks.

- 2 Insert both solid mineral fuel burning rear bricks (Part No: FM5-040). There are relief holes in the back of the bricks to allow the brick to sit over the bolts in the back of the stove.

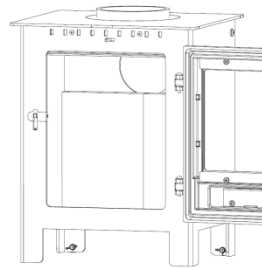

- 3 Insert a solid mineral fuel bottom side brick on the Left hand side of the Stove (Part No: FM5-041).

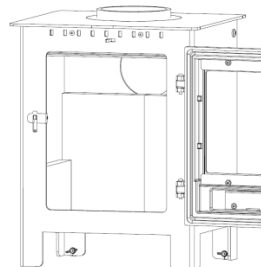

- 5 Insert a solid mineral fuel top side brick on the Left hand side of the Stove (Part No: FM5-042).

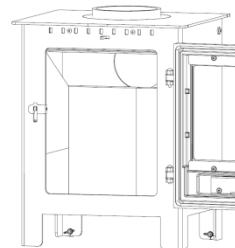

- 6 Insert solid mineral fuel base brick (FM5-047).

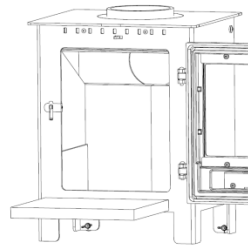

- 7 Insert the solid mineral fuel burning grate (Part No: FIREM-001).

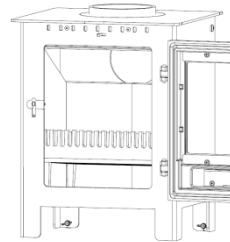

- 8 Insert the remaining solid mineral fuel bottom side brick on the Right hand side of the Stove (Part No: FM5-046 & FM5-041) then fit the remaining solid mineral fuel top side brick on the right hand side of the stove (FM5-042) You may have to slide the grate to the left to slide the top brick in.

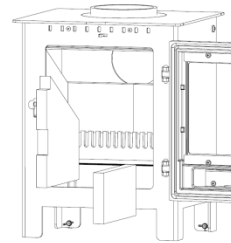

- 9 Re-Insert both original top baffle bricks (FM5-040T).

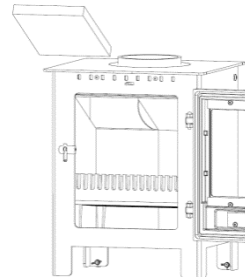

- 10 Insert the solid mineral fuel ash pan (Part No: 525-013A).

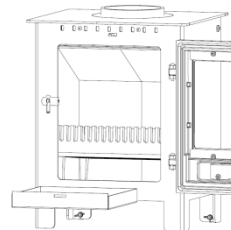

LIGHTING AND CONTROLLING THE FIRE

Before lighting the fire for the first time, ensure that the baffle, the riddling grate and the side and back bricks are in position. Burning without either will result in the stove castings overheating and being damaged.

Open the primary and secondary air control fully. Place some tightly rolled paper on top of some crumpled paper on the base towards the back of the stove. On top of this, place some small pieces of wood and on top of that a few small pieces of mineral fuel. Light the crumpled paper and close the door. Once the fire becomes established and the fuel is burning, more fuel can be added. When the stove is hot and the fuel is no longer producing smoke, the secondary air control can be reduced. The burning rate of the fire can now be controlled with primary air control. As air from the primary air slider flows up through the grate it will cool the grate, preventing it from overheating and becoming damaged. Reducing the primary air control and, as a result, introducing air only from the secondary air control, will allow the fuel to burn but the grate will not be cooled resulting in damage to the grate. When controlling the fire, the air inlet should be altered gradually. Reducing the primary air dramatically and all at once on a hot stove will cause the fuel to clinker and will result in a build-up of gases and smoke which could ignite with a bang the moment air is reintroduced.

EXTENDED BURNING

Before adding a large amount of fuel, the grate should be de-ashed and the ash pan emptied. Add the fuel sloping it from the front coal bar up to the back of the stove to the level of the top of the back brick. Open the primary air control and let the fire burn for a period on high rate in order to heat the stove back up to temperature and drive off the moisture and gases in the fuel. If a lot of smoke is produced on reloading, the secondary air control can be opened further to keep the smoke back from the glass. As the fire gets back up to the temperature, reduce the secondary air control and reduce the primary air inlet to suit the burning rate. The exact setting of the air controls depends on a number of variables including: the flue draught, the fuel used and the installation, so the best setting for your stove can only be learned by experience.

ASH REMOVAL

The level of ash should not be allowed to build up to the level of the grate. If the level of ash becomes too high the air through the grate will become restricted causing the grate to overheat and preventing the fuel from burning efficiently.

MINERAL FUELS

Ordinary bituminous house coal is not recommended and must not be burned in smoke control areas. Burning bituminous house coal will result in a sooty stove and chimney, and the stove glass will require cleaning regularly. There are numerous natural anthracites and manufactured smokeless fuels that will burn cleanly and have more reliable burning characteristics. A list of these fuels and their suitability is produced by HETAS (www.hetas.co.uk). Consult your local fuel merchant to find out what is available in your area. Petro coke should not be used as it burns very hot and may damage the stove casting.



NOTE

The above text should be used as a guide only. The ideal operation of your stove depends on a number of factors, which vary with each installation, and so gaining experience operating your stove is the only way to learn its best operation.



NOTE

The stove as with any other metal products will expand and contract. A ticking noise may occur. This is normal for this type of appliance.

TECHNICAL INFORMATION

Normal heat output - wood	5.0kW
Nominal heat output - solid mineral fuel	5.0kW
Weight of stove	51kg
Minimum chimney draught	11.5Pa
Mean flue gas temperature - Wood	260°C
Mean flue gas temperature – solid mineral fuel	232°C
Flue gas mass flow – wood	3.9g/s
Flue gas mass flow – solid mineral fuel	5.0g/s
Tested net efficiency – wood	81.9%
Energy class	A+
Energy index	108
Seasonal Efficiency	71.6%



Declaration of performance according to Regulation (EU) 305/2011

Ref No: ESS- Esse 1-CPR-2017-19

1	Product Type	Esse Engineering roomheater burning solid fuel without supply of hot water in accordance with NEN EN 13240:2001 + Amd A2:2004
2	Product model designation	Esse 1, Serial No. -
3	Intended use	Roomheater burning solid fuel without supply of hot water
4	Manufactured by	Esse Engineering Ltd. Long Ing, Barnoldswick, Lancashire, BB18 6BJ Tel:01282 813235 Fax: Email:enquiries@esse.com
5	Manufacturer's authorised representative	Esse Engineering Ltd.
6	System of assessment and verification of constancy of performance	System 3
7	Notified laboratory name and address	The notified laboratory SGS Nederland B.V., Laboratory number 608 performed the determination of the product type specification on the basis of type testing under system 3 and issued the test report Ref: EZKA/14/0146-1
8	Declared performance:-	
	Harmonized Technical specification:	NEN EN 13240:2001 + Amd A2:2004
	Essential characteristics	Performance – Wood Performance - Ancit
	Fire Safety:- Reaction to fire	A1
	Clearance distances to combustible materials	Rear – 700mm Sides – 550mm Ceiling – NPD
	Risk of burning fuel falling out	PASS
	Emission of combustion products	CO – 0.08% CO–0.13%
	Surface temperatures	PASS PASS
	Electrical safety	N/A N/A
	Cleanability	PASS PASS
	Maximum operating pressure	N/A N/A
	Flue gas temperature at nominal heat output	260 °C 214 °C
	Mechanical resistance to carry a chimney	NPD NPD
	Nominal output	5.0kW 5.0kW
	Room heating output	5.0kW 5.0kW
	Water heating output	N/A N/A
	Gross efficiency	74.2% 80.4%
	Net Efficiency	81.9% 82.1%
9	The performance of the product identified in points 1 and 2 is in conformity with the declared performance given in point 8.	

Signed for and on behalf of the manufacturer by:

_____ CRAIG NUTTER _____
_____ 18/06/19 _____
_____ [ORIGINAL SIGNED] _____
 (Name) (Date of Issue) (Signature)

MAINTENANCE

CLEANING THE STOVE

The stove should only be cleaned when it is cold. The exterior can be dusted with a firm brush. Do not use a cloth, as this will drag on the paint finish leaving lint on the surface. From time to time it may be necessary to renovate the exterior by repainting. High temperature stove paints in aerosol form are available from your stove dealer. Do not use this form of paint until the stove is cold and always read the instructions on the container before starting to paint. The door glass is made of a special heat resisting ceramic and may be cleaned when cold with proprietary glass cleaning liquids and a dry cloth.

SHUTTING DOWN THE STOVE (LONG TERM)

The following procedure should be followed if the stove is not to be used for a long period, summertime for instance. Remove all the ashes from the grate and ash pan and use a vacuum cleaner nozzle to clean ash from the base of the stove. Remove the baffle plate and brush the flue ways. Close the door and open the air inlets fully. This action will allow air circulation through the flue ways and help avoid corrosion and condensation.

SERVICING

Regular maintenance should be carried out by a competent engineer, at least once a year.

CONDITIONS OF GUARANTEE

Your ESSE is guaranteed against defects arising from faulty manufacture for 2 years when supplied by an ESSE Specialist.

Upon registration of the warranty, ESSE will extend the guarantee period to 5 years from purchase. Your details must be registered with us by either returning the completed warranty card or by completing registration on-line at www.esse.com. The warranty must be registered within 1 month of installation to qualify for the 5 year warranty.

The appliance must be only used for normal domestic purposes and in accordance with our instructions, be correctly installed and serviced.

The guarantee does not cover:

- Installation
- Wear and tear
- Parts deemed to be replaceable or service parts that may be replaced during the normal usage of the appliance
- Damage caused by impact, spillage, water ingress, or condensate attack from flue or by using unsuitable fuels

This guarantee is personal to the original purchaser and not transferable. Any stove or defective part replaced shall become the Company's property.

HOW TO PROCEED WITH A COMPLAINT

If you have cause for dissatisfaction with your stove, you should first contact your ESSE dealer, who will bring your concerns to our attention. We will assess the nature of the complaint and either send replacement parts for your dealer to fit, or arrange for an ESSE engineer to inspect the appliance and carry out any work that may be deemed necessary. If the fault is not actually due to faulty manufacture but some other cause i.e. misuse, failure to install correctly, or failure to service at regular intervals, a charge will be made to cover the cost of the visit and any new parts required.

SPARE PARTS

Only genuine ESSE spare parts are recommended. Parts that may need occasional replacement are:

Fig. 9 – Wood Burning Parts

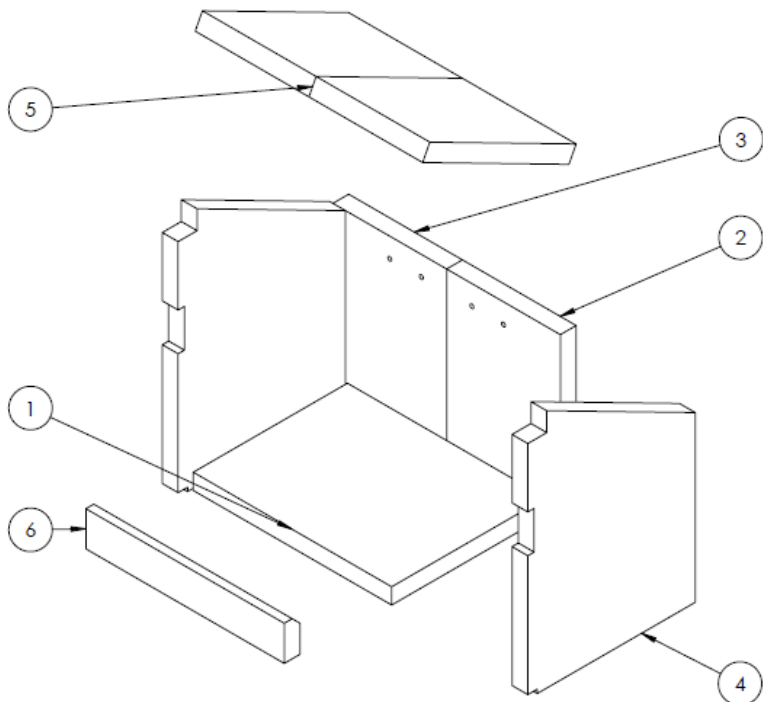

ITEM NO.	PART NUMBER	DESCRIPTION	QTY.
1	FM5-043	BASE BRICK	1
2	FM5-040B 2022 RH	BACK BRICK	1
3	FM5-040B 2022 LH	BACK BRICK	1
4	FM5-042L	ONE PIECE SIDE BRICK	2
5	FM5-040T	TOP BAFFLE	2
6	FM5-044	BASE BRICK FRONT	1

Fig. 10 – Solid Fuel Burning Parts

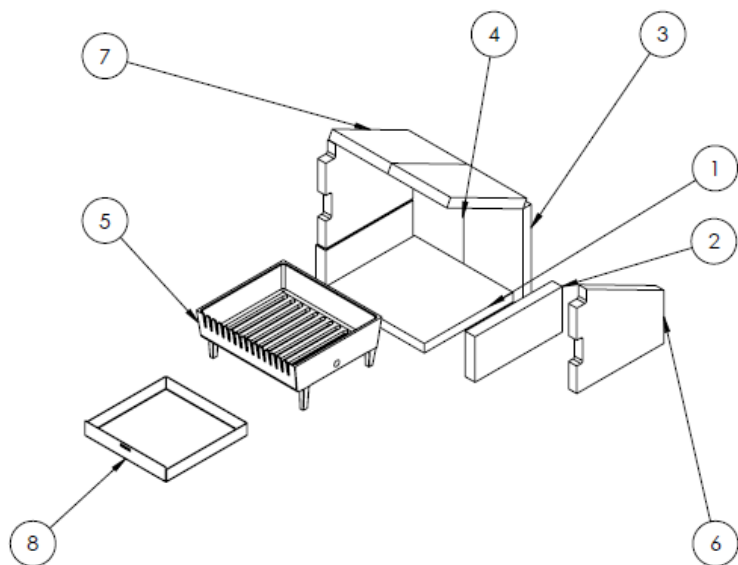

ITEM NO.	PART NUMBER	DESCRIPTION	QTY.
1	FM5-047	SOLID MINERAL FUEL BASE BRICK	1
2	FM5-041	SIDE LOWER BRICK	2
3	FM5-040B 2022 RH	BACK BRICK	1
4	FM5-040B 2022 LH	BACK BRICK	1
5	Esse FIREM-001B 2022	525-BOTTOM GRATE	1
6	FM5-042	SIDE BRICK	2
7	FM5-040T	TOP BAFFLE	2
8	525=013A	525/500/FM5 ASPHAN NEW STYLE	1

Fig. 6 – Additional Parts

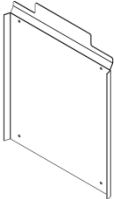
PART No:	DESCRIPTION	IMAGE
FM5-014	DOOR GLASS	--
FM5-048	REAR HEATSHEILD KIT	

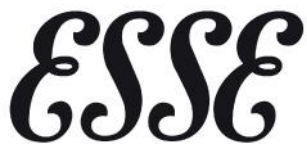

ESSE Engineering Limited.

Ouzledale Foundry, Long Ing, Barnoldswick, Lancashire, BB18 6BJ

Tel: 01282 813 235, **Fax:** 01282 816 876

Web: www.esse.com