

HWAM[®]

intelligent heat

Since 1973

HWAM I 40/55c with customised frame



NEW

HWAM I 40/55 INSERT

CUSTOMISED

FRAMES

hwam[®]
intelligent heat

ECODESIGN
READY

29-0884 UK



Left or right hinged door



Danish design by Sørig & Jacobsen



An airwash system ensures correct air circulation supporting a clean pane



Danish production backed by more than 40 years of experience



A unique closing system that closes tight and ensures optimum combustion



Classic cast iron door or modern glass door with optional customised frame



Convection



Efficient combustion and easy operation thanks to HWAM[®] Autopilot™



Optional fresh air kit to connect to external air



Optional fan

Frame options



Standard frame

Standard measures. This frame is integrated as standard if no customised frame is chosen.



Without bent edges

3 mm thick flat frame without bent edges. Made with customised measures with or without sides.

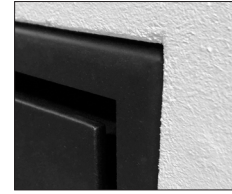

With bent edges

Frame with bent edges. Made with customised measures with or without sides.

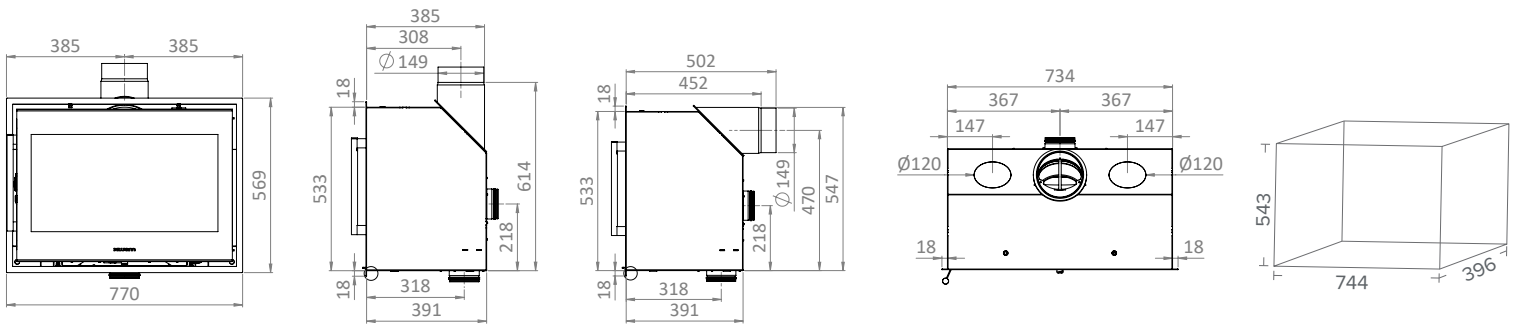
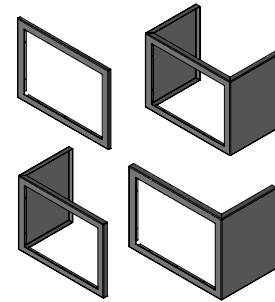
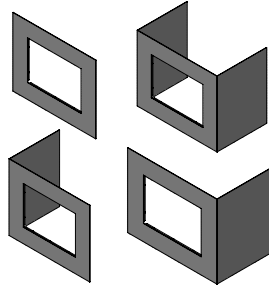
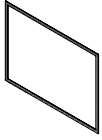

NB! Illustrations show HWAM I 40/55 with standard frame.



Frame for an in-built depth of 350 mm

Standard measures. With this frame an in-built depth of 350 mm is achieved.

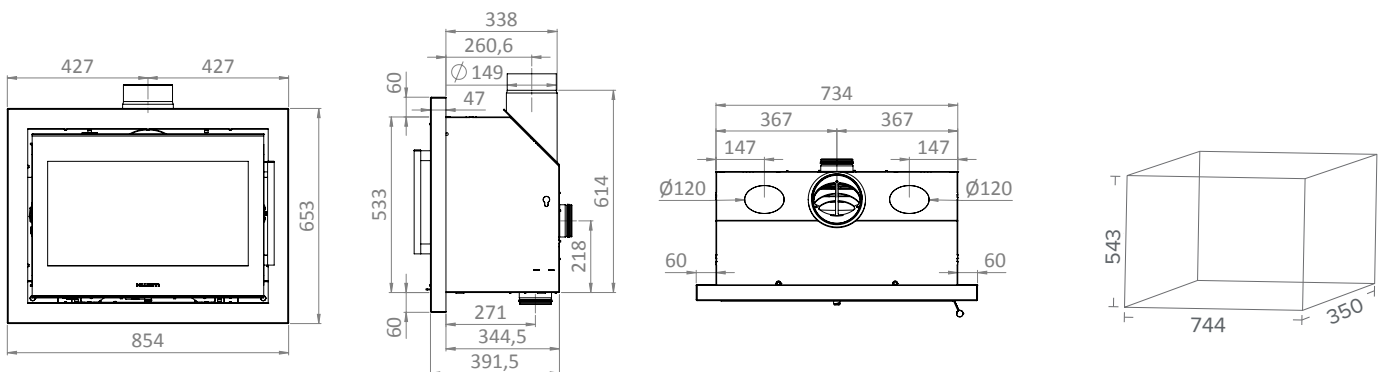
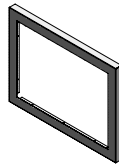

Technical data

Capacity	4-8 kW
Nominal heat output	6.4 kW
Smoke outlet	Ø 150 mm
Energy efficiency class HWAM® Autopilot™	A+
Net efficiency HWAM® Autopilot™	80%
Door	Classic or modern
Door	Right hinged or left hinged
Chimney draught, min. (recommended)	11 Pa
Width of combustion chamber	55 cm

Approvals & registrations

- EN 13229
- NS 3058/3059
- Art. 15a
- BlmSchV Stufe 2
- LRV
- Brændeovnsbekendtgørelsen 2018



Classificazione ★★★★★



Combustion air system



*Pending registration