

# Dovre 250

Free Standing Stove

- including Smoke Control Version



## Instructions for Use, Installation & Servicing

For use in GB & IE (Great Britain & Republic of Ireland).

*These instructions apply to Dovre 250 (DV-250) when fitted with a Smoke Control kit (Part No.DV250SCKIT).*

### **IMPORTANT**

**THE OUTER CASING, FRONT AND GLASS PANEL BECOME EXTREMELY HOT DURING OPERATION AND WILL RESULT IN SERIOUS INJURY AND BURNS IF TOUCHED. IT IS THEREFORE RECOMMENDED THAT A FIREGUARD COMPLYING WITH BS 8423:2002 IS USED IN THE PRESENCE OF YOUNG CHILDREN, THE ELDERLY OR INFIRM.**

Do not attempt to burn rubbish in this appliance.

Please read these Instructions carefully before installation or use.

Keep them in a safe place for future reference and when servicing the fire.

The commissioning sheet found on page 3 of these instructions should be completed by the Installer.



# Contents

## Dovre 250 Smoke Control Version

Covering the following models:

DV-250

<b>Appliance Commissioning Checklist .....</b>	<b>3</b>
<b>User Instructions .....</b>	<b>4</b>
Getting Started .....	4
User Instructions .....	6
Care & Maintenance.....	9
<b>Troubleshooting .....</b>	<b>12</b>
<b>Installation Instructions .....</b>	<b>14</b>
Installation Checklist.....	14
Pre-Installation Instructions.....	18
Installing the Appliance.....	19
Commissioning.....	22
<b>Maintenance &amp; Servicing.....</b>	<b>24</b>
<b>Technical Appendix.....</b>	<b>26</b>
Spare Parts List.....	30
Service Records.....	31

## WARRANTY

To receive your Two Year Warranty your Dovre appliance must have been purchased from our Expert Retailer Network and registered within one month of purchase or installation. They will also provide a Five Year Casting Warranty for all cast iron stoves and the cast iron door of steel stoves.

Please note that all warranties are effective from the date of purchase. Any Dovre product purchased outside of our Extended Retailer Network, or not registered within the stated time will carry a standard 12 month warranty.

Registration will help your retailer to provide their TWO YEAR WARRANTY on your new appliance and, where applicable, the FIVE YEAR WARRANTY ON CASTINGS\*. The second year's warranty is dependant on your appliance being installed and serviced (12 months after installation) by an appropriately qualified person (HETAS in the UK or equivalent in other countries) with the certificate of installation and the Commissioning Report on Page 3 completed and retained by the end user.

This warranty is not transferable and is extended only to, and solely for, the benefit of the original purchaser of the Stove or Fireplace. Please retain your dated sales receipt as a proof of purchase. Consumable items such as glass, firebricks, grate parts, log retainers, baffles, ash pans and rope seals which are either subject to normal wear and tear or parts that require replacement in connection with normal maintenance are not covered by the Warranty.

Full terms and conditions are detailed in the Warranty Statement on the Dovre website [www.dovre.co.uk](http://www.dovre.co.uk). In the event of any conflict of information the wording on the website shall prevail.

Important Note: Should any problems be experienced with your product, claims must first be submitted to the Expert Retailer where the appliance was purchased from who will offer immediate assistance or contact Dovre on your behalf.



# Appliance Commissioning Checklist

To assist us in any guarantee claim please complete the following information:-

## Retailer appliance was purchased from:

Name: \_\_\_\_\_

Address: \_\_\_\_\_

Telephone number: \_\_\_\_\_

## Essential information - MUST be completed:

Date Installed: \_\_\_\_\_

Model Description: \_\_\_\_\_

Serial Number: \_\_\_\_\_

## Installation Engineer:

Company Name: \_\_\_\_\_

Address: \_\_\_\_\_

Telephone number: \_\_\_\_\_

## Commissioning Checks - to be completed and signed:

Is flue system correct for the appliance:	YES <input type="checkbox"/>	NO <input type="checkbox"/>
Flue swept and soundness test complete:	YES <input type="checkbox"/>	NO <input type="checkbox"/>
Smoke test completed on installed appliance	YES <input type="checkbox"/>	NO <input type="checkbox"/>
Spillage test completed	YES <input type="checkbox"/>	NO <input type="checkbox"/>
Use of appliance and operation of controls explained	YES <input type="checkbox"/>	NO <input type="checkbox"/>
Clearance to combustible materials checked	YES <input type="checkbox"/>	NO <input type="checkbox"/>
Instruction book handed to customer	YES <input type="checkbox"/>	NO <input type="checkbox"/>
CO Alarm Fitted	YES <input type="checkbox"/>	NO <input type="checkbox"/>
Smoke Control Kit Fitted (If installed in a Smoke Control Zone)	YES <input type="checkbox"/>	NO <input type="checkbox"/>

Signature: ..... Print Name: .....

# Getting Started

## Welcome

*Congratulations on purchasing your Dovre 250 Stove, if installed correctly Dovre hope it will give you many years of warmth and pleasure for which it was designed.*

*The purpose of this manual is to familiarise you with your stove, and give guidelines for its installation, operation and maintenance. If, after reading, you need further information, please do not hesitate to contact your Dovre retailer.*

## 1. General Points

- 1.1 Before installation and/or use of this appliance please read these instructions fully and carefully to ensure that you have fully understood their requirements.

**The appliance must be fitted by a registered installer\*, or approved by your local building control officer.**

- 1.2 All local regulations, including those referring to national and European Standards need to be complied with when installing the appliance.
- 1.3 Only use for domestic heating in accordance with these operating instructions.
- 1.4 You must burn only approved fuels. Do not use with liquid fuels or as an incinerator.
- 1.5 Appliance surfaces become very hot when in use. Use a suitable fireguard<sup>‡</sup> if young children, elderly or infirm persons are present. Dovre offer firescreens, sparkguards and hearthgate systems for protection. Your Dovre dealer can advise you about these products.
- 1.6 Do not place photographs, TV's, paintings, porcelain or other combustible items on the wall or near the appliance. Exposure to hot temperatures will cause damage. Do not place furniture or other items such as drying clothing closer than 1m from the front of this appliance.
- WARNING:** Extra fuel should not be stored on or next to the appliance. Only keep enough fuel for immediate use nearby and never leave the appliance unattended for long periods with any combustible material in close proximity.
- 1.7 Extractor fans or cooker hoods must not be placed in the same room or space as this can cause appliance to emit fumes into the room.
- 1.8 Do not obstruct inside or outside ventilation required for the safe use of this appliance.
- 1.9 Do not make unauthorised changes to the appliance.



**‡In the U.K. these products must conform to the latest edition of BS 8423, Fireguards for use with solid fuel appliances.**

**If appliance is operating unattended they must conform to the latest edition of BS 3248**

**\*Registered on the Competent Persons Scheme (GB only see page 29/ INFO (Republic of Ireland)).**

- 1.10 The chimney must be swept at least once a year. See Section 16.
- 1.11 Do not connect, or share, the same flue or chimney system with another appliance.
- 1.12 This appliance is designed to be used with the doors shut.
- 1.13 These instructions must be left with the user and kept with the original instructions they superseded.

## SERIAL NUMBER

- 1.14 This number is required when ordering spare parts or making warranty claims.

It is found on the data plate on the back of the appliance.

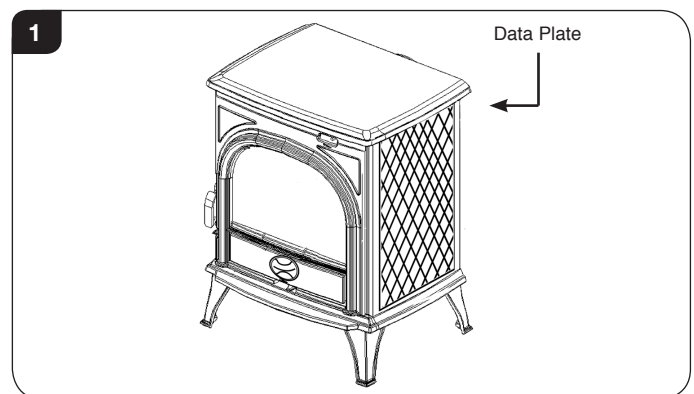

## Double Air System

Several Dovre appliances have double air systems providing cleaner burning, and greater efficiency and control, see Diagram 2.

- 1) **Airwash** - air drawn over the window cleans the glass. The source of Primary Combustion air when burning wood.
- 2) **Primary Air**- for use initially when establishing fires.
- 3) **Cleanburn** - Secondary air is preheated through a heat exchanger to combust unburned hydrocarbons, providing a cleaner and more efficient burn.

**For Air Controls, see Diagrams over page.**

# Getting Started

## AIR CONTROLS

1.15 Use a protective gloved hand to operate.

**DO NOT OPERATE THE AIR CONTROLS WITH BARE HANDS**

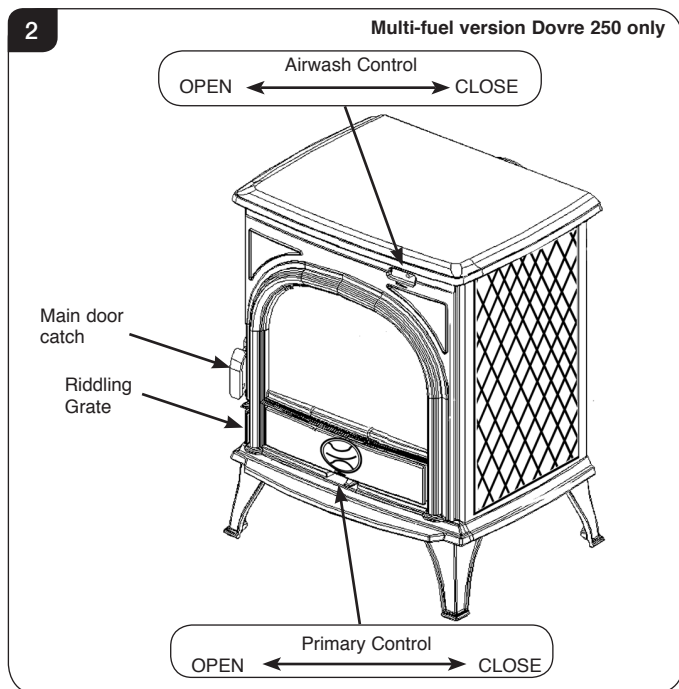

## DOOR HANDLE

1.16 Use the tool provided to operate.

**DO NOT OPEN THE DOOR WITH BARE HANDS**

DO NOT OPEN THE DOORS WHEN THE FIREBOX IS FULL OF FLAMES - WAIT FOR THEM TO DIE DOWN.

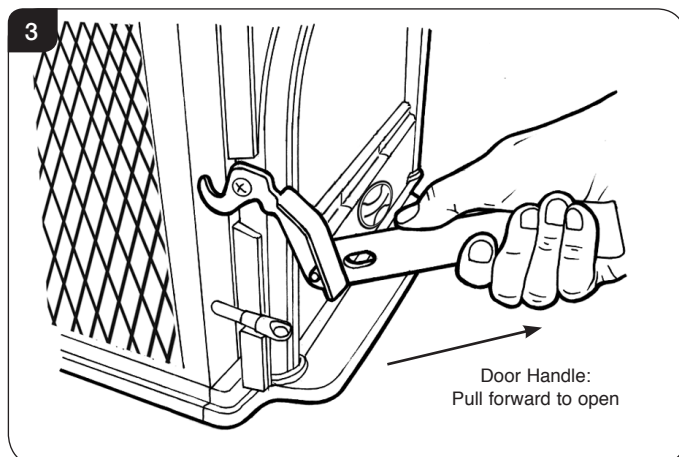

## WARNING



Properly installed, operated and maintained, this appliance will not emit fumes into the room. Occasional fumes from de-ashing and refuelling may occur.

Persistent fume emission is potentially dangerous and must not be tolerated.

If fume emission does persist:

- Open doors and windows to ventilate the room.
- Leave the room.
- Allow fire to burn out and safely dispose of fuel from the appliance.
- Check for chimney blockage and clean if required.
- Do not attempt to relight until the cause of the emission has been identified and corrected
- If necessary seek expert advice.
- All open flued appliances can be affected by temporary atmospheric conditions which may allow fumes to enter the house. Because of this an electronic carbon monoxide detector conforming to the latest edition of BSEN50292 must be fitted in the same room as the appliance. The existence of an alarm must not be considered a substitute for ensuring regular servicing and maintenance of the appliance and chimney system.

**IF THE ALARM SOUNDS FOLLOW THE INSTRUCTIONS GIVEN ABOVE.**

## 2. Using the Appliance for the First Time

- 2.1 To allow the appliance to settle, and fixing glues and paint to fully cure, operate the appliance at a low temperature for first few days.
- 2.2 Do not touch the paint during the first period of use.
- 2.3 During this time the appliance may give off some unpleasant odours. Keep the room well ventilated to avoid a build-up of fumes.
- 2.4 Please be aware that, during use, rope seals may discolour. This is normal.

# Getting Started/User Instructions

## 3. Recommended Fuels

NOTE: This appliance has been independently tested to PD6434 and is exempt from the controls that generally apply in smoke control areas hence is considered suitable for use in Smoke Control Area when burning wood and ONLY when fitted with the relevant Smoke Control kit.

To meet the Smoke Control requirement this appliance must be operated correctly in order to minimise the amount of smoke produced.

### 3.1 Wood Logs:

Burn only seasoned timber with a moisture content of less than 20%. To ensure this allow cut wood to dry for 12 to 18 months.

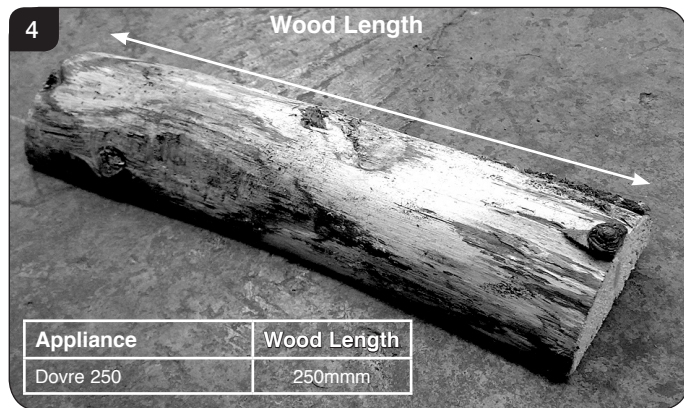

Poor quality timber:

- Causes low combustion efficiency
- Produces harmful condensation
- Reduces effectiveness of the airwash and life of the appliance

**Do not burn construction timber, painted, impregnated / treated wood, manufactured board products or pallet wood.**

### 3.2 Solid fuel:

**ONLY USE APPROVED SMOKELESS FUELS IN A SMOKE CONTROL AREA.**

- Burn only anthracite or manufactured briquette smokeless fuels listed as suitable for use with closed heating appliances

**Do not burn bituminous coal, 'petro-coke' or other petroleum based fuels as this will invalidate the product guarantee.**

**\*In the U.K:**

- Ring the Solid Fuel Association advice line on 0845 601 4406 for details
- Visit their web site at [www.solidfuel.co.uk](http://www.solidfuel.co.uk)

### 3.3 Fuel consumption.

As tested at nominal heat output to the requirements of EN 13240: 2001 for intermittent operation:

Description	Fuel Consumption	
	Kg/hour Wood	Kg/hour Briquette Smokeless fuel
Dovre 250	1.45	0.69

3.4 For advice on suitable solid fuels contact your local approved coal merchant\*.

A number of factors can affect the performance of the appliance. See *Troubleshooting Section* for details.

## Fuel Overloading

The maximum amount of fuel specified in this manual should not be exceeded, overloading can cause excess smoke.

## 4. Lighting the Appliance

4.1 For best results set air controls as shown in Diagram 5.

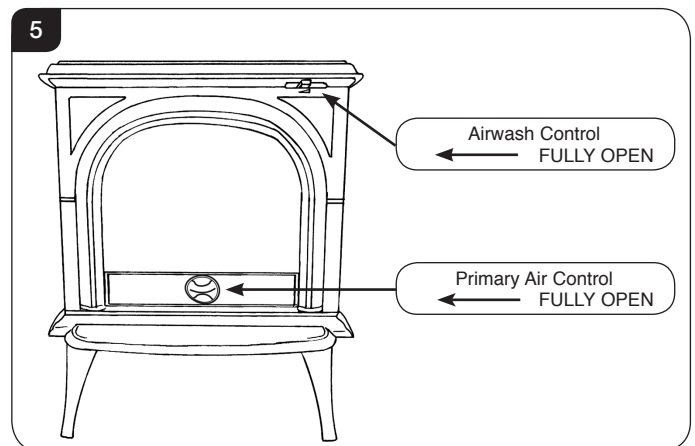

4.2 Place firelighters or paper and dry kindling wood on the grate.

A successful fire initially requires plenty of kindling to establish a hot firebox and warm the chimney to aid flue performance.

4.3 Light the paper or firelighters, see Diagram 6.





# User Instructions

- 4.4 Leave the door slightly open as the fire establishes and the glass warms to avoid build up of condensation.
- 4.5 Add larger pieces of wood.  
Do not use full sized logs at this stage, build up gradually in size. Too many logs may smother the fire.

**Do not load fuel above the log guard and the lower edge of baffle at the back of the firebox, see Diagram 7.**

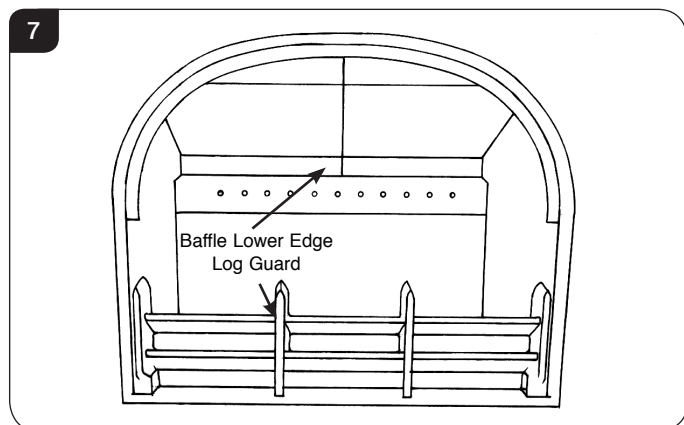

- 4.6 Close the door and follow the instructions for Running the Appliance.

**Do not run with the door slightly open except for initial lighting as this could cause over-firing and damage the appliance.**

## 5. Running the Appliance Wood Burning

- 5.1 Close the **Primary air control** and use the **Airwash** to control the burn rate when appliance is at operating temperature, see Diagram 8.

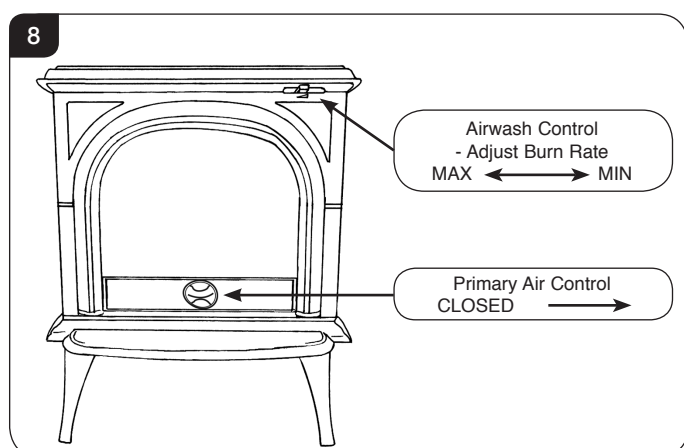

Wood burns best on a bed of ash (approx. 25mm (1") deep).

Small amounts of **Primary Air** can sometimes help to maintain a hot fuel bed.

- 5.2 Do not burn large amounts of fuel with the **Airwash Control** closed for long periods of time. This reduces the glass cleaning effect of the Airwash and causes tars and creosotes to build-up in the appliance and flue system.

- 5.3 When in use, burning the appliance at a high temperature for a short period reduces tars and creosotes.

**WARNING: DO NOT OPERATE THE APPLIANCE WITH THE PRIMARY AIR CONTROL OPEN OR AIRWASH ON MAXIMUM FOR LONG PERIODS OF TIME AS THIS COULD CAUSE OVER-FIRING AND MAY CAUSE PERMANENT DAMAGE.**

- 5.4 Do not refuel when a large amount of flames are in the firebox as this could cause smoke or flames to spill into the room.

## 6. Refuelling the Appliance - Wood

- 6.1 Open the Primary and Airwash air controls fully.

**Rake the embers evenly over the firebed to establish a glowing firebed. If the firebed is low add a small amount of kindling wood to help re-establish the fire.**

Stack the logs in an open arrangement, see Diagram 9.

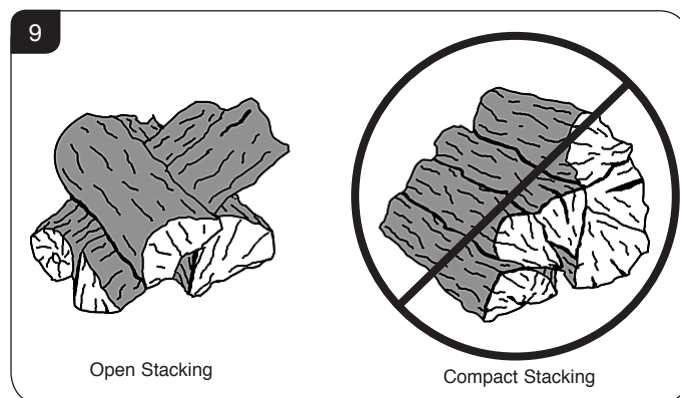

Open stacking allows oxygen to easily reach every part of the fire.

Compact stacking will make the wood burn slower as wood can only reach the outside of the fire. This will cause the fire to smoulder and produce smoke.

- 6.2 After refuelling:  
**Burn the new logs at a high temperature for a few minutes before closing the Primary Air control. Adjust the burn rate using the Airwash control.**

**Do not close the air controls until the fire is burning well.**

- 6.3 Experience establishes settings to suit personal preferences.
- 6.4 Do not burn large amounts of fuel with the **Airwash control** closed for long periods of time. This reduces the glass cleaning effect and causes tars and creosotes to build-up in the appliance and flue system and will produce excessive amounts of smoke.
- 6.5 When in use, burning the appliance at high output for a short period also reduces tars and creosote.
- 6.6 When running the appliance **refuel little and often for clean, efficient burning.**

# User Instructions

- 6.7 Wood burns best on a bed of ash (approx 1" deep).

**A bright and clean firebox indicates the appliance is burning well.**

- 6.8 **Do not load fuel above the log guard and the lower edge of baffle at the back of the firebox, see Diagram 7.**

## Fuel Overloading

The maximum amount of fuel specified in this manual should not be exceeded, overloading can cause excess smoke.

- 6.9 **Do not burn continuously with the door open.**

## 7. Running the Appliance Multi-fuel

- 7.1 Allow the fire to become established before adding the solid fuel:

—Set air controls, see Diagram 10.

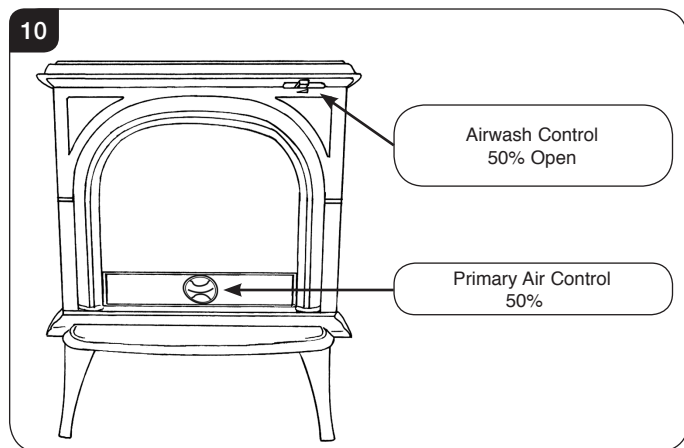

- 7.2 De-ash the grate before re-fuelling (see *User Instructions, Section 7*).

Open the **Primary Air Control** fully to establish a glowing bed before adding new fuel.

Burn new fuel at a high temperature for a few minutes before adjusting the **Primary Air Control** to the desired setting.

Refuel little and often for clean, efficient burning.

When burning solid fuel more primary air will increase the heat output and burn the fuel more quickly.

A small amount of Airwash can sometimes help to keep the glass clean but will reduce efficiency.

- 7.3 Experience establishes settings to suit personal preference.

- 7.4 Do not burn large amounts of fuel with the **Primary Air Control** on a low combustion setting for long periods of time. This reduces the glass cleaning effect of the Airwash and causes tars and creosotes to build-up in the appliance and flue system.

- 7.5 When in use, burning the appliance at a high temperature for a short period reduces tars and creosotes.

**WARNING: DO NOT OPERATE THE APPLIANCE WITH THE PRIMARY AIR CONTROL OPEN FOR LONG PERIODS OF TIME AS THIS COULD CAUSE OVER-FIRING AND MAY CAUSE PERMANENT DAMAGE.**

- 7.6 **ONLY USE APPROVED SMOKELESS FUELS IN A SMOKE CONTROL AREA.**

- 7.7 **Only anthracite or smokeless fuels suitable for use in closed appliances must be burned in this appliance.**

- 7.8 **Do not burn bituminous coal, 'petro-coke' or other petroleum based fuels as this invalidates the product guarantee.**

- 7.9 **Do not load fuel above the log guard and the lower edge of baffle at the back of the firebox, see Diagram 7.**

## 8. Burning Tips

- 8.1 **Fuel Quality (Wood)**

Use wood with a moisture content of less than 20%. Seasoned logs have the bark beginning to lift and peel away and cracks radiating from the centre. They feel lighter than fresh cut wood of a similar size and sound hollow when struck against each other. Logs should not feel damp or have moss and fungal growths.

Symptoms related to wet wood:

- Difficulty starting and keeping a fire burning well.
- Smoke and small flames.
- Dirty glass and/or firebricks.
- Rapid creosote build-up in the chimney.
- Low heat output.
- Short burn times, excessive fuel consumption and blue/grey smoke from the chimney.

**Run at a high temperature for a short period each day to avoid large build-ups of tars and creosote within the appliance and the flue system.** Use Stovax Protector chimney cleaner to reduce this problem.

## 9. Shut Down

- 9.1 If there is still burning fuel in the firebox, Dovre do not recommend shutting down the air controls completely unless there is a chimney fire in progress (see Section 9 for advice). Closing the controls during the burning process will cause poor combustion and could lead to a build up of gasses that could ignite dangerously.
- 9.2 Always have enough air entering the stove to maintain some flame within the firebox.
- 9.3 If it is necessary to shut down the appliance then run on a high setting until all of the fuel has been burnt before closing the air controls.



# User Instructions/ Care & Maintenance

## 10. Extended Burning

- 10.1 It is possible to get the appliance to burn for extended periods of time. In order to do this:
- De-ash prior to final refuelling.
  - Burn new fuel at a high temperature for a few minutes before adjusting the **Primary Air Control**.
  - Set air controls to low combustion settings. This will gradually blacken the glass but it will clear when operated at a high temperature for a short period.
  - Use smokeless fuel or small, thick logs depending on fuel desired.

**NOTE: It is not recommended to extend the burning period in Smoke Control Areas. This process increases the amount of smoke produced.**

An appliance without a Smoke Control kit fitted will burn longer than an appliance that complies to the restrictions of a Smoke Control Area.

## 11. Ash Removal

**Do not allow ash to build up as it may cause damage and adversely effect the performance of the appliance. Warning: Ash can remain hot long after appliance has been in use.**

- 11.1 **All Models:**
- De-ash the appliance before filling with new fuel. Do not allow ash to build up on the underside of the grate as this can cause premature failure.
  - Riddle with the tool provided, see Diagram 11.
  - Leave a layer of ash to start the new fire on. Wood burns best on a bed of ash (approx. 25mm (1") deep).

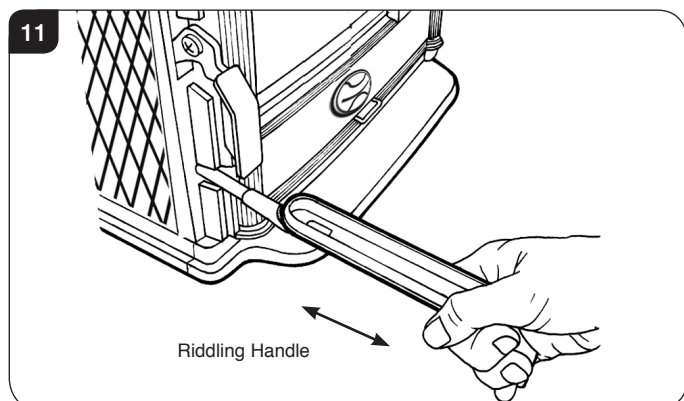

- Move the Riddling Tool backward and forward 3 or 4 times to remove the ash. Do not force the handle beyond its natural stop point. The ash will fall into the ashpan.

- Open the door, see Diagram 12.

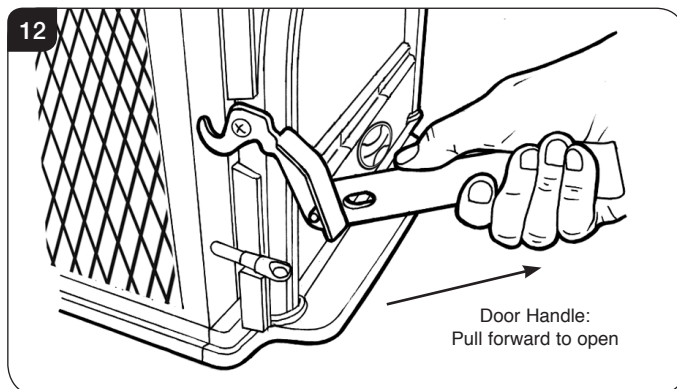

**Warning: Ash can remain hot long after appliance has been in use.**

Using gloves, carefully remove ashpan using tool supplied, see Diagram 13. Ensure the tool is fully engaged before operation. Practise this technique before hand with a cold ashpan.

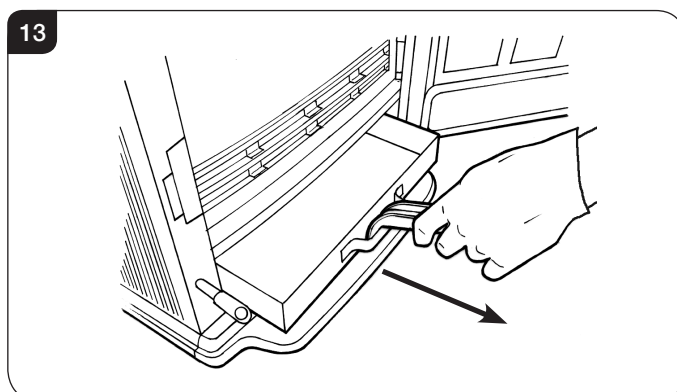

- Place the ash into an Ash Caddy (Part No. 4227) or other suitable container.
- De-ash at least once a week.

**Do not place hot ash in a container made from plastic or any other combustible material.**

## 12. Over-Firing

- 12.1 Do not over-fill with fuel or run at high temperatures for long periods or over-firing can occur.  
**WARNING: DO NOT OPERATE THE APPLIANCE WITH THE PRIMARY AIR CONTROL OPEN OR AIRWASH ON MAXIMUM FOR LONG PERIODS OF TIME AS THIS COULD CAUSE OVER-FIRING AND MAY CAUSE PERMANENT DAMAGE.**
- 12.2 **Over-firing can cause permanent damage to the appliance and invalid the product warranty.**

**i** \*Registered on the Competent Persons Scheme (GB only) see page 29/ INFO (Republic of Ireland).

# Care & Maintenance

## 13. Chimney Fire

- 13.1 **If a chimney fire occurs:**
- Shut all air controls immediately.
  - Evacuate the building.
  - Call the fire brigade.
  - Do not re-enter the building until it is confirmed safe.
- 13.2 **Do not use the appliance after a chimney fire until:**
- a) It has been inspected by a registered installer\*, confirming the appliance is safe to use.
  - b) The chimney system has been inspected and swept by a chimney sweep, confirming the system is structurally sound and free from obstruction\*.
  - c) It is repaired as required before re-use. Use only genuine Dovre replacement parts to keep your appliance in safe, efficient working order.

## 14. General Cleaning

- 14.1 Clean and inspect the appliance regularly, especially in periods of heavy use. Regular cleaning and maintenance will help give many years of safe use.
- 14.2 **Allow appliance to cool thoroughly to avoid risk of burns.**
- 14.3 Clean regularly, according to level of use.
- Remove the ash completely  
(see *User Instructions, Section 11*).
- 14.4 Check internal components for damage and for obvious build up of soot, ash or debris above the flue baffle(s) (these can be found in the upper part of the firebox). Use a torch if necessary.
- 14.5 If there are any signs of a build up of debris above the flue baffle(s) either:
- Arrange for the chimney to be swept (see *User Instructions, Section 16*).
  - Remove the baffles and clear the debris (see *Pre-Installation Instructions, Section 4*).
- 14.6 To refresh painted finishes a touch up spray is available. Contact your Dovre retailer quoting the serial number found on the appliance data badge.
- Do not use aerosol sprays near an operating appliance. Do not use abrasive cleaner or cleaning pads.**
- 14.7 Clean enamel finishes using warm soapy water and a soft clean cloth.
- Wipe dry with a soft clean cloth before re-lighting. Do not leave unit without drying, as this may cause rust.
- 14.8 Check that the door shuts properly and creates an effective seal. Leaking door seals prevent the appliance working properly.

## 15. Cleaning Glass

- 15.1 Keep the glass clean with correct use of the Airwash system and good quality fuel.
- 15.2 Sometimes additional cleaning may be required. Before undertaking this operation allow appliance to cool fully. Do not clean hot glass.
- 15.3 **On appliances with printed glass do not use cleaning agents that have a high alkaline or acidic content, for example Stovax Gel Cleaner, these are aggressive cleaning agents designed to be used with heavily stained clear glass. On printed glass surfaces, use Stovax Glass Cleaner (Stovax No.4103) which is better formulated for this application.**
- 15.4 Before applying a cleaning agent remove any dust and loose soot with a damp cloth.
- 15.5 Use an appropriate glass cleaner. Apply the cleaning fluid to a cloth before rubbing onto the glass. Apply carefully and do not apply excessively. Try to prevent any run off which could soak into the rope seals around the edge of the glass. Soot can also contain acidic particles that can cause corrosive damage to printed glass.
- 15.6 Remove dirt with a moist cloth and buff dry.
- 15.7 **Some types of wood can cause a white residue to form on the glass. If this occurs it should be cleaned off at least once a week during periods of heavy usage. If the liquid cleaning agents recommended do not remove this residue use a dry cleaning pad which will help remove these white marks.**
- 15.8 Before relighting the appliance ensure the glass is fully dried. If the rope seal has absorbed excess cleaning agent it is advisable to replace the rope as soon as possible to preserve the printed finish of the glass.



\*Registered on the Competent Persons Scheme (GB only) see page 29/ INFO (Republic of Ireland).

## 16. Chimney Sweeping

- 16.1 To maintain safe and efficient use of the appliance, the chimney/flue must be inspected and swept at least once a year by a qualified chimney sweep\*.
- If the appliance is used continuously throughout the year, or it is used to burn wood, more frequent sweeping is recommended.
- The best time to have the chimney swept is at the start of the heating season.
- 16.2 The chimney, any connecting flue pipe and the appliance flue ways, if incorporated, must be regularly cleaned.
- 16.3 Ensure adequate access for cleaning where it is not possible to sweep through the chimney.
- 16.4 If the chimney is believed to have previously served an open fire it must be swept a second time within a month of regular use after installation.

## 17. Care Of Stove

Dovre has a range of cleaning and maintenance products and accessories to keep your appliance in good working order. Your Dovre retailer can advise you on suitable items for your stove and provide genuine spare parts such as replacement glass, door sealing rope and firebricks. View the extensive range at [www.dovre.co.uk](http://www.dovre.co.uk) by clicking on *Accessories*. In addition, an annual service by a competent engineer is recommended to keep your stove in the best possible condition.



## 18. Seasonal Use

- 18.1 Clean and service the appliance if not used during the warmer months, as detailed in the *Maintenance and Servicing* section.
- 18.2 Set the air controls to 50% to keep the appliance ventilated and stop the build-up of any moisture inside.
- 18.3 Before re-lighting the appliance:
- Remove the baffles.
  - Clear any debris that may have accumulated.
  - Check the flue is clear of any blockages.

# Troubleshooting

## Troubleshooting

	Symptom	Cause	Solution
OPERATION	Difficulty starting the fire and keeping it burning well	Low flue draught	Consult your installer
		Wet wood (over 20% moisture)	Use dry seasoned wood (less than 20% moisture content)
	Poor burning control	High flue draught	Consult your installer
	Short burn times	Wet wood (over 20% moisture) Insufficient amount of fuel - Refer to the table in section 3	Use dry seasoned wood (less than 20% moisture content)
	Excessive heat output (Over firing)	High flue draught	Consult your installer
		Air control left fully open	Close air control to reduce output
	Low heat output	Low flue draught	Consult your installer for advice on suitable flue system
		Wet wood (over 20% moisture)	Use dry seasoned wood (less than 20% moisture content)
Excessive fuel consumption	High flue draught	Consult your installer for advice on suitable flue system	
	Over dry wood	Do not use constructional timber or pallet wood	
SMOKE EMISSIONS	Smoke and small flames	Wet wood (over 20% moisture)	Use dry seasoned wood (less than 20% moisture content)
	Intermittent smoke spillage into room when appliance door is opened	Low flue draught	Consult your installer for advice on suitable flue system
		Incorrect additional ventilation air in to building	Consult your installer
	Continuous smoke spillage into room when appliance in use	Blocked flue	Open all doors and windows to ventilate the room. Allow the fire to burn out. Check flue for blockage. Do not re-use until cause of spillage is identified. Consult your installer for advice
Blue/grey smoke from chimney	Wet wood (over 20% moisture)	Use dry seasoned wood (less than 20% moisture content)	
ADVERSE WEATHER	Windy days, intermittent smoke spillage into room when appliance door is opened	Down draught in flue caused by air turbulence caused by nearby buildings or trees	Weather conditions combined with the flue terminal position can have an effect on the appliance performance. Consult your installer
	Calm days, intermittent smoke spillage into room when appliance door is opened	Over size flue giving poor flue draught	Weather conditions combined with the flue terminal position can have an effect on the appliance performance. Consult your installer
	Damp/Rainy days lighting and burning problems	Flue temperature low / rain water inside flue	Use good quality wood to start and maintain the fire, consult your installer to fit a rain cowl
	Wind noise from the air control	High flue draught	Consult your installer for advice on suitable flue system

# Troubleshooting

	Symptom	Cause	Solution
THE APPLIANCE	Rapid creosote build-up in the chimney	Wet wood (over 20% moisture)	Use dry seasoned wood (less than 20% moisture content). Operate at a high temperature for short periods each time the appliance is used to avoid large build-ups of tars and creosotes
	Tar coming from flue joints	Appliance operated at continuous low temperatures	Operate at a high temperature for short periods each time the appliance is used to avoid large build-ups of tars and creosotes. See user instructions for correct use of air control
		Using poor quality wood	Use dry seasoned wood (less than 20% moisture content)
	Strong pungent smell after the appliance is lit	Appliance operated at continuous low output	Operate at high output for short periods. See user instructions for correct use of air control
		Using poor quality wood	Use dry seasoned wood (less than 20% moisture content)
	Wind noise from the air control	High flue draught	Consult your installer for advice on suitable flue system
	Dirty firebricks	Wet wood (over 20% moisture)	Use dry seasoned wood (less than 20% moisture content)
	Dirty glass	Wet wood (over 20% moisture)	Use dry seasoned wood (less than 20% moisture content)
	Glass blackening	Using poor quality wood	Use dry seasoned wood (less than 20% moisture content)
		Low flue draught	Consult your installer for advice on suitable flue system
Incorrect use of air control		See user instructions for correct use of air control	
Appliance operated at continuous low temperatures		Operate at high output for short periods. See user instructions for correct use of air control	

FLUES	The flue system has two main functions:
	<ul style="list-style-type: none"> <li>- To safely remove the smoke, fumes and combustion gases from the building.</li> <li>- To provide a sufficient amount of flue draught (suction) in the appliance to ensure the fire keeps burning.</li> </ul>
	The flue draught is caused by rising hot gases when the appliance is lit.
	Tar and creosote are a major cause of chimney fires. If the appliance experiences problems with tar build up consult a chimney sweep before continued use of the appliance.
	<b>For advice on the correction of persistent flue problems consult a qualified heating engineer before continuing to use the appliance.</b>



# Installation Checklist

## Please Note

This section is intended to give an overview of the product performance and essential information required for installing the appliance. It is intended for qualified engineers who are already familiar with Dovre products.

**For full details and expanded information please see the Technical Appendix at the back of this manual.**

## 1. Dovre 250 Dimensions

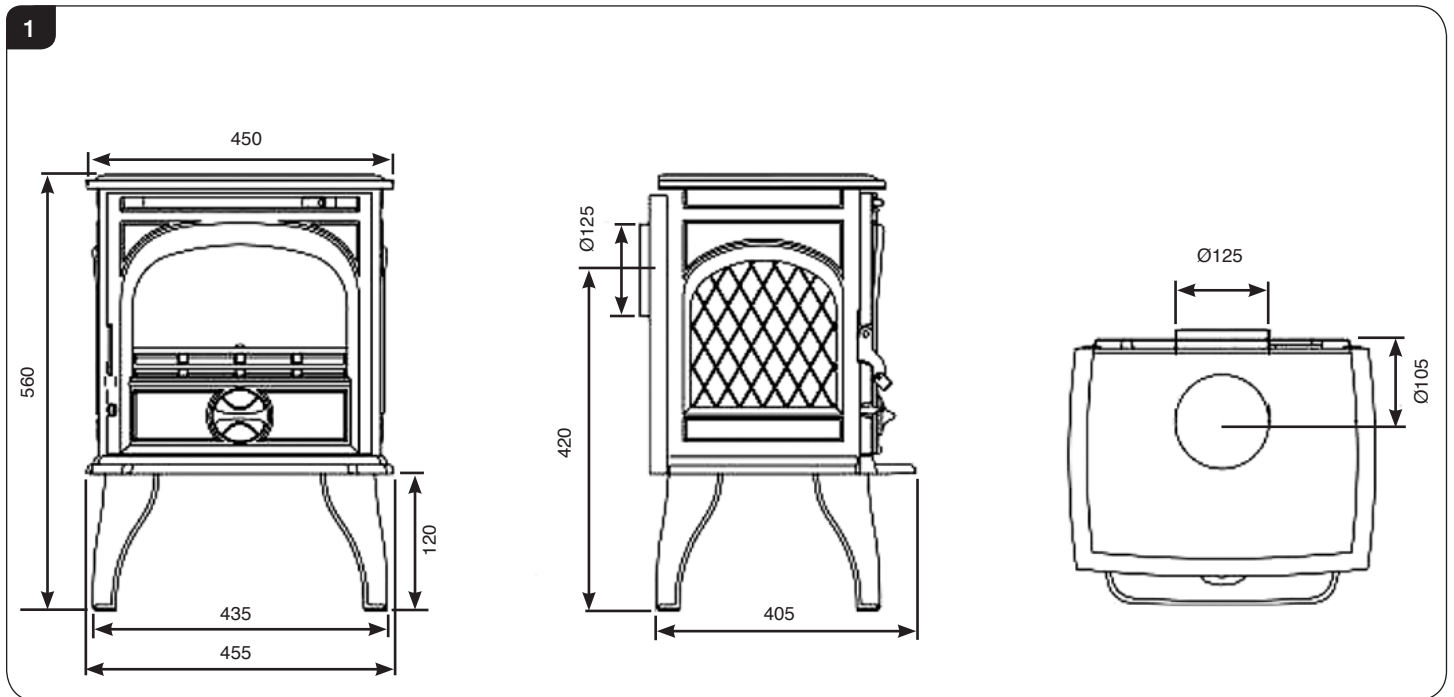

All dimensions are in mm (25.4mm = 1")



In the U.K. Additional information covering the installation of the appliance may be found in the following British Standards: BS EN 15287, BS6999, BS8303.

## 2. Essential Information

<b>GENERAL</b>	<b>Model:</b> <b>Dovre 250</b> <b>Dovre 250 Smoke Control Version - fitted with Smoke Control Air Slider (Part No. DV250SCKIT)</b>			<b>Dovre 250</b>
	Nominal Heat Output	Wood	kW	4.9
		Solid Fuel	kW	4.9
	Efficiency	Wood	%	78
		Solid Fuel	%	78
	CO @ 13% O <sub>2</sub>	Wood	%	0.11
Solid Fuel		%	0.07	
Weight		Kg	80	
Recommended Fuels	Wood	Seasoned Wood (less than 20% moisture content)		
	Solid Fuel	Briquette smokeless fuel suitable for closed appliances (Ancit-Phuracite-Taybrite-Homefire Ovals)		

**As tested to the requirements of EN 13240 for intermittent operation**

<b>FLUES</b>	Flue/Chimney Size ‡May be reduced to 128mm (5") if burning approved smokeless fuels or burning wood in an appliance approved for use in a DEFRA smoke control area	Without flue liner Round (Diameter)	mm	‡153
			inch	‡6
		Without flue liner system (Square)	mm	135
			inch	5½
		With Liner of Factory made system (diameter) installed in accordance with manufacturers instructions	mm	‡153
			inch	‡6
	Flue/Chimney minimum height**	All products **must be 4.5m from the hearth to the top of the flue, with no horizontal sections and a maximum of 4 bends. Bends must have angles of less than 45 degrees from the vertical.	m	4.5
			feet	15
	Flue Draught	Min	mm Wg	1.0
		Nominal		1.25
Max		2.0		
Flue Gas Mass Flow	Wood	g/s	5.2	
	Solid Fuel	g/s	5.1	
Flue Gas Temperature at Spigot/Socket	Wood	°C	310	
	Solid Fuel	°C	310	
Flue Outlet Size (Top or Rear Option)	All	mm	128	
		inch	5	

**European Min Spec for Chimney Flue - T400 N2 D 3 G50**

<b>VENTILATION</b>	<b>A) Traditionally Built Homes</b>		<b>B) Modern Construction Homes</b>	
	• Where leakage is greater than 5m <sup>3</sup> /hour/m <sup>2</sup> .		• Where leakage is less than 5m <sup>3</sup> /hour/m <sup>2</sup> .	
	• Ventilation normally required = 550mm <sup>2</sup> per kW output over 5kW		• Ventilation normally required = 550mm <sup>2</sup> per kW	
	<b>A</b>	Additional Ventilation	mm <sup>2</sup>	None
			cm <sup>2</sup>	None
			in <sup>2</sup>	None
<b>B</b>	Additional Ventilation	mm <sup>2</sup>	2695	
		cm <sup>2</sup>	26.9	
		in <sup>2</sup>	4.3	

For full technical details on ventilation see Technical Appendix on Page 28

# Installation Checklist

## 3. Minimum Dimensions - Hearth

3.1 Hearth construction must comply with the building regulations in force. The appliance must stand on a non-combustible constructional hearth which is at least 125mm thick with the minimum dimensions as shown in Diagram 2.

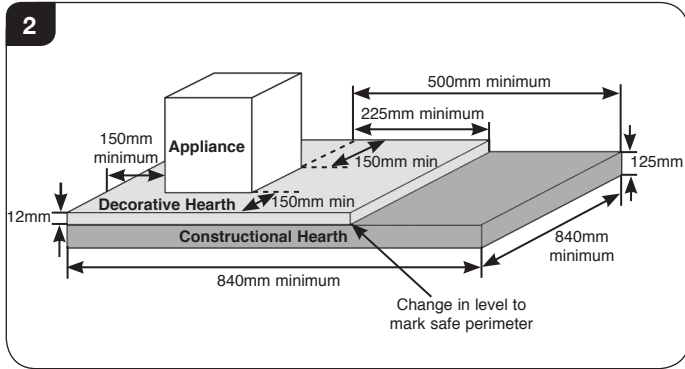

3.2 If this appliance is installed in an elevated setting it is recommended to increase the 225mm hearth depth to safely contain any falling logs or embers. The higher the appliance is installed the deeper the hearth should be to avoid scorched floor coverings.

## 4. Clearances

**IMPORTANT: INSTALLATION MUST COMPLY WITH CURRENT BUILDING REGULATIONS**

**ENSURE THAT SUFFICIENT CLEARANCES ARE PROVIDED BETWEEN THE FLUE PIPE AND ANY COMBUSTIBLE MATERIALS IN THE FIREPLACE IN ACCORDANCE WITH THE RULES IN FORCE.†**

4.1 When installing a Dovre 250 stove it is important to observe the following clearances to both **combustible** and **non-combustible** materials. Also ensure that a clearance of 1 meter is maintained in front of the appliance when operating.

### Fireplace: Minimum Clearances Above & to the Sides

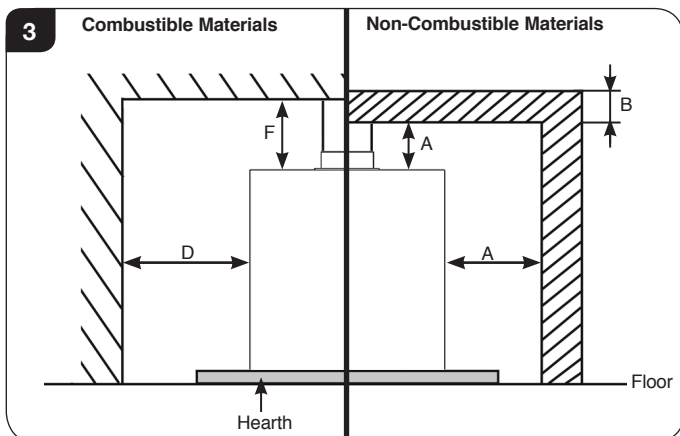

### Fireplace: Minimum Clearances to the Rear

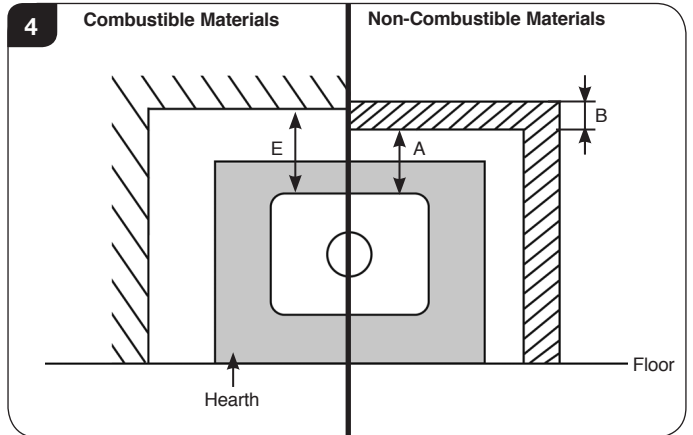

### Non-Combustible Materials

- 4.2 All appliances will require some clearance between them and any non-combustible materials to allow for either:
- Installation, servicing or accessing controls.
  - Convection in order for the appliance to function properly.

Recommended: Minimum clearances for installation/servicing/convection is:

Rear - 25mm	Sides - 50mm	Top - 100mm
-------------	--------------	-------------

**NOTE: If the non-combustible surface is less than 200mm thick additional clearances may be required.** This requirement ensures that the non-combustible material does not transmit excessive heat through the wall onto combustible material which might be placed against it.

See Diagrams 3 & 4 (Fireplaces) & Diagram 5 (Freestanding) and table below.

Distance to Non-combustible Materials		
Distance of Appliance to Wall (A)	Minimum Thickness of wall (B)	Minimum Height of Wall (C)
0mm - 50mm*	200mm	Height of appliance + 300mm OR 1200mm from the hearth (take largest dimension)
51mm - 300mm	75mm	
300mm+	No requirement	No requirement

† England and Wales – Document J / Scotland - Part F/Document J (Republic of Ireland only)

# Installation Checklist

## Freestanding Installation

5

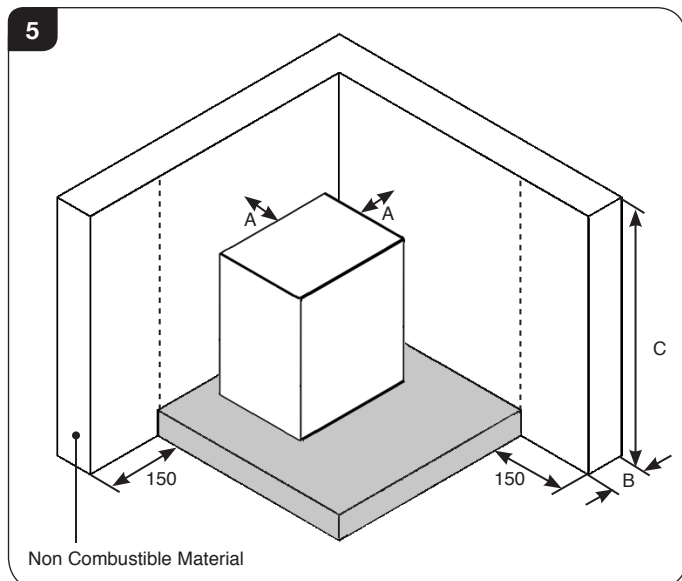

## Combustible Materials

4.3 It is essential for safety to ensure the following clearances to combustible materials are maintained.

See Diagrams 3 & 4 and table below.

Model	D (side)	E (Rear)	F (Above)
Dovre 250	400	200	N/A

# Pre-Installation Instructions

## 1. General

- 1.1 To make the installation of the appliance easier it is best to remove the internal components before fitting into the builders opening/studwork.

### PACKING LIST

- User & Installer Instructions
- Warranty card
- Pair leather gloves
- Door handle tool
- Flue collar
- 4 X legs
- Fire Cement
- Scraper

### STANDARD FEATURES

- Primary air (under grate air for full multi-fuel use)
  - Airwash (for wood burning / clean glass)
  - Preset secondary air control (to ensure complete burning of flue gases)
  - Riddling grate system for clean de-ashing
  - Top or rear flue exit option
- 1.2 For the best results remove the following components as set out below.

## 2. Removal of the Log Guard

- 2.1 To remove the Log guard:
- Raise the right hand side of the Log Guard to its natural stop, see Diagram 1.

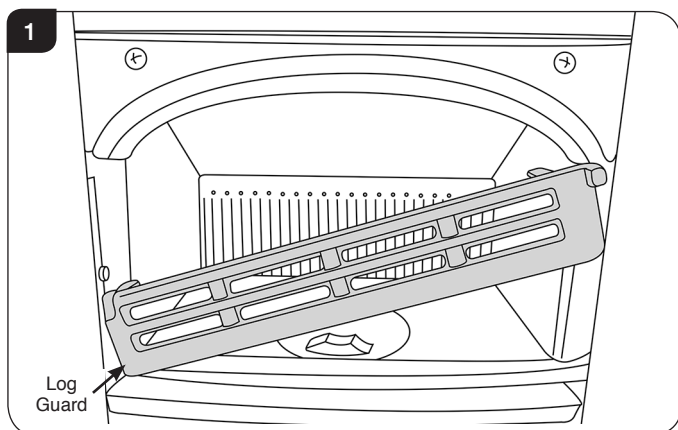

- Slide the Log Guard to the right.
- Rotate the left hand side forward and remove from the firebox.

**Do not use appliance without the log guard in position.**

## 3. Removal of the Fire Bricks

- 3.1 Remove the firebricks as part of the routine maintenance. This can be carried out without the use of tools.
- 3.2 Allow the appliance to cool fully before removing firebricks.
- 3.3 Take care when handling, as bricks can become fragile after use. Life span depends on the type of fuels burnt and the level of use.
- 3.4 **Replace damaged bricks as soon as possible.**

To remove the bricks:

- 3.5 Remove the side firebricks.
- 3.6 Slide the rear firebricks forward to remove.
- 3.7 Replace in reverse order.

## 4. Removal of the Baffles

- 4.1 The appliance is fitted with a baffle in the top of the firebox to maintain efficient combustion.
- 4.2 Allow the appliance to cool fully before removing the baffle system.
- 4.3 To remove the baffle:
- Remove the log guard from the appliance for access.
  - Lift the baffle plate.
  - Rotate the baffle and slide it out through the front of the appliance.
  - Replace in reverse order.
- 4.4 Remove and clean the baffle system to ensure the flue ways are clear of soot and debris and to ensure the safe, efficient operation of the appliance. The frequency of cleaning will depend on the appliance operating conditions.
- 4.5 The baffle system is designed to give safe and efficient operation of the appliance. **Replace any damaged baffles immediately.**
- 4.6 **Do not modify the baffle system.**



# Installation Instructions

## 1. Installing the Appliance

Each installation is unique to the property so it is not possible to give details to suit every setting. The installation must comply with Building Regulations† and be made using "best practice" construction methods‡.

Many fireplace openings have a supporting lintel. Do not remove without supporting the remaining structure of the building. **Do not support the structure with the appliance or the flue system.**

### 1.1 Take care when installing the appliance. Careless handling and use of tools can damage the finish and/or area.

Assemble the appliance by attaching the legs to the base of the appliance, see Diagram 1.

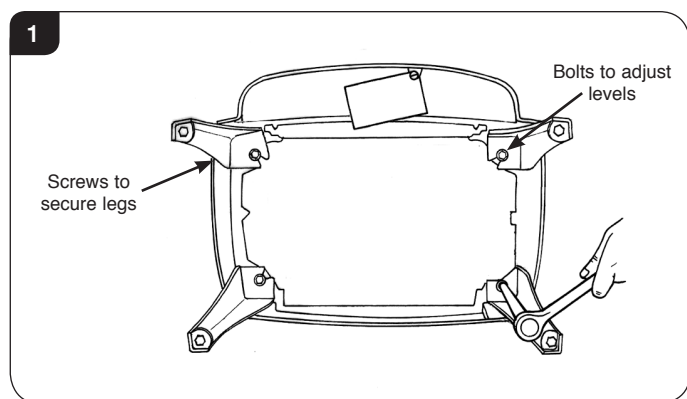

Choose top or rear flue exit.

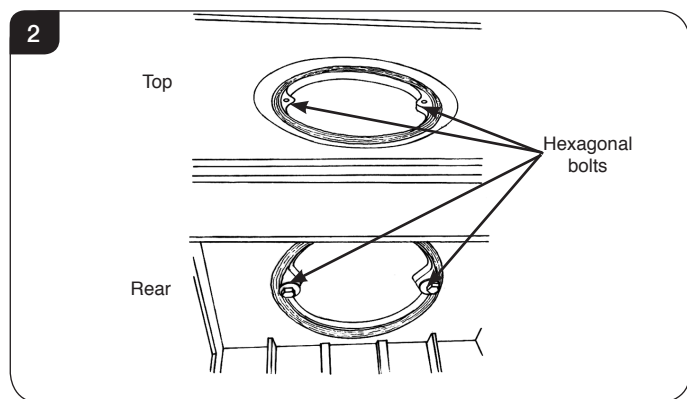

- Fit flue collar and blanking plate to suit.
- Attach flue collar to top or rear with hexagonal bolts, see Diagram 2.
- Seal with fire cement.
- Secure blanking plate with clamping bar, see Diagram 3.

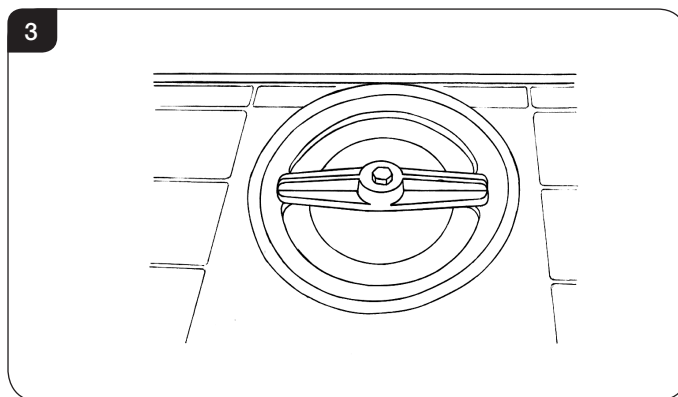

### 1.2 Top flue pipe installation

- Lift appliance into position. Take care not to damage the hearth finish.
- Level using adjustable bolts, see Diagram 1.
- Connect appliance to the chimney using flue pipe.
- Secure with self tapping screw.
- Seal the connecting joints with fire cement.

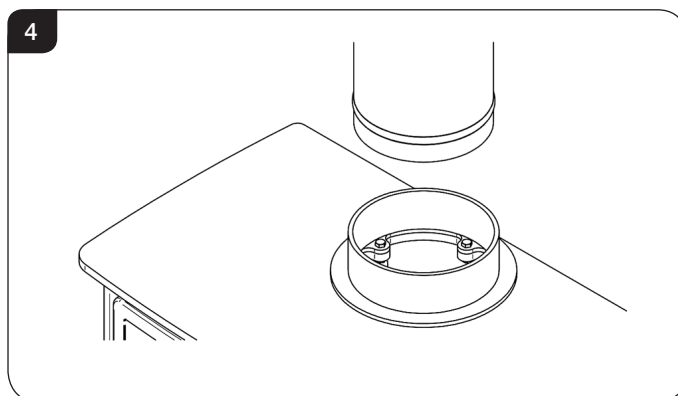

**i** † England and Wales – Document J / Scotland - Part F/Document J (Republic of Ireland only)  
‡ the latest edition of BS 8303, BS EN 15287, BS 7566

# Installation Instructions

The flue must be installed in accordance with manufacturers instructions.

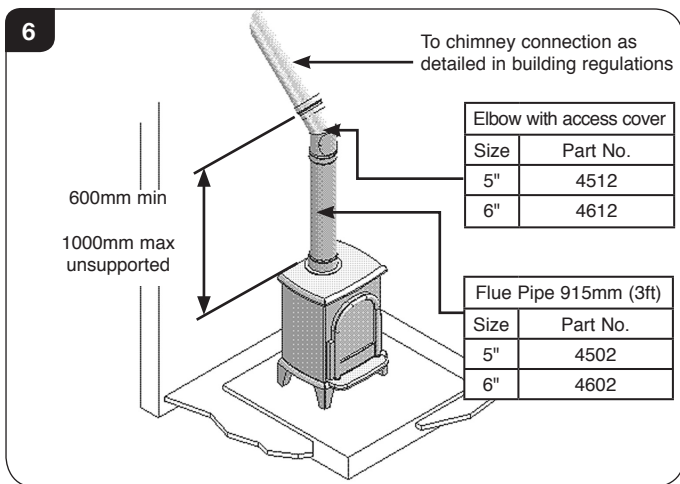
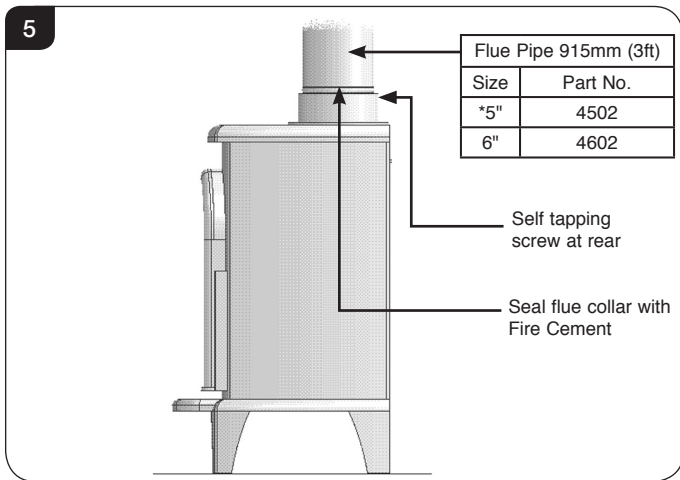

## 1.3 Rear flue pipe installation

- Insert a tee into the flue collar. The tee piece is used as cleaning access.
- Lift appliance into position. Take care not to damage the hearth finish.
- Level using adjustable bolts, see Diagram 1.
- Connect tee to the chimney using flue pipe.
- Secure with self tapping screw.
- Seal the connecting joints with fire cement.

**Do not use a 90° elbow to make this connection.**

The flue must be installed in accordance with manufacturers instructions.

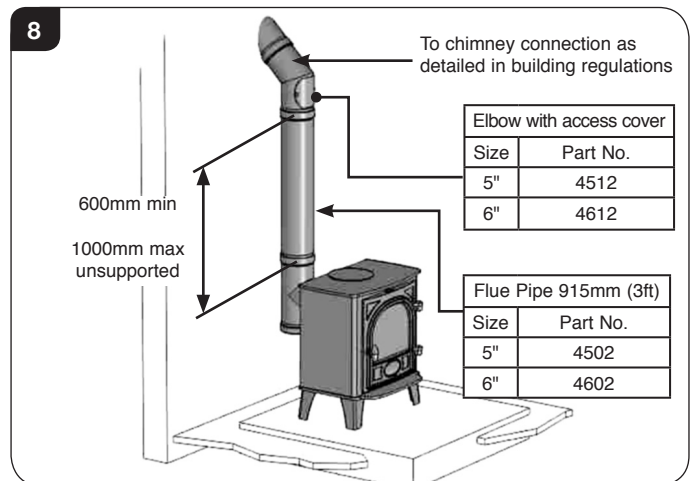
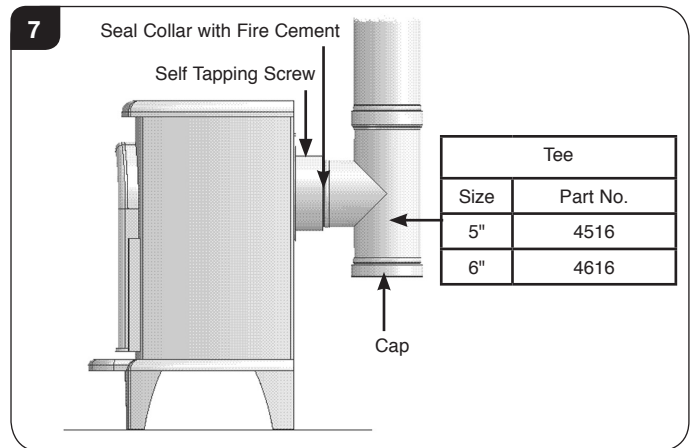

## 2. Fitting the Smoke Control Kit

This appliance has been independently tested to PD6434 and is exempt from the controls that generally apply in smoke control areas hence is considered suitable for use in Smoke Control Area when burning wood and ONLY when fitted with the relevant Smoke Control kit.

To make this appliance exempt from the controls that govern smoke control areas the Airwash Control Slider must be replaced with the Smoke Control Air Slider supplied in the kit.

Product Code	Appliance
DV250SCKIT	Dovre 250

# Installation Instructions

To install the Smoke Control kit:

- 2.1 Remove the Log Guard, see Pre-Installation Section 2.
- 2.2 Remove the Baffle, see Pre-Installation, Section 4.
- 2.3 Remove the Airwash chamber by removing the 2 screws, see Diagram 9.

The nuts are located on the back of the Airwash chamber. Use a 10mm spanner to hold the nuts.

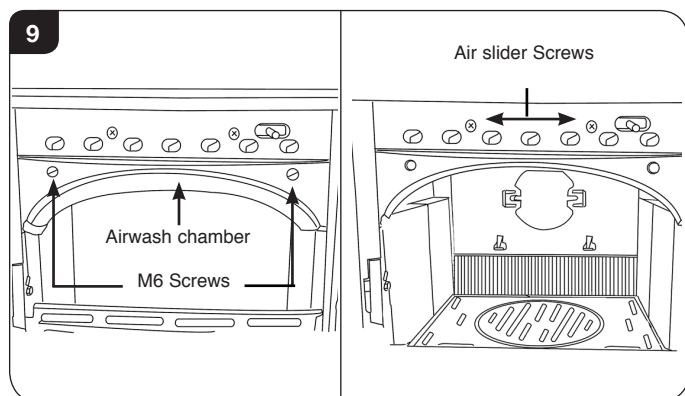

**Note:** If the kit is fitted before appliance installation the top plate can be removed for easy access.

- 2.4 Remove the 2 M6 screws on the Air slider, Diagram 9 & 10. The nuts are located on the back of the Air slider. Use a 10mm spanner to hold the nuts.

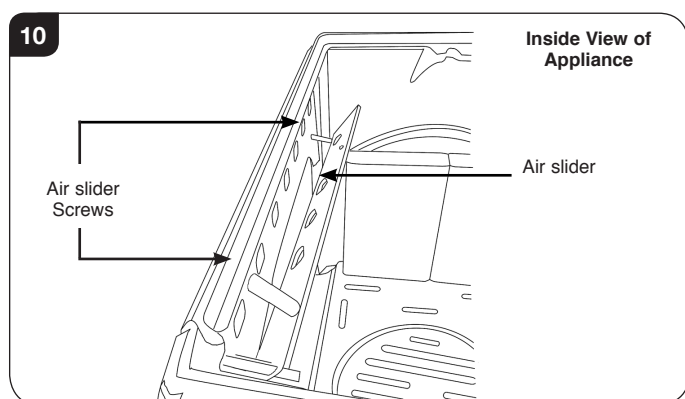

- 2.5 Replace Air slider with the Smoke Control version.
- 2.6 Fitting is the reverse of the above.
- 2.7 Ensure the Air slider screws are tightened to a tension that ensures movement when the Airwash is operated.

## 3. CO Alarms

All open flued appliances can be affected by temporary atmospheric conditions which may allow fumes to enter the house. **Building regulations require that whenever a new or replacement fixed solid fuel or wood/biomass appliance is installed in a dwelling a carbon monoxide alarm must be fitted in the same room as the appliance.** Further guidance on the installation of the carbon monoxide alarm is available in the latest edition of BS EN50292 and from the alarm manufacturer's instructions.

HETAS recommend the unit is permanently fixed in accordance with the manufacturer's installation instructions or with the guidance contained in Approved Document J where no other information is available.

**Provision of an alarm must not be considered a substitute for either installing the appliance correctly or ensuring regular servicing and maintenance of the appliance and chimney system.**

# Commissioning

## Commissioning

### 1.1 To commission:

- Replace the internal components.
- Check the soundness of door seals, castings and joints.
- Check the operation of the air controls.

### 1.2 Now carry out a final smoke draw test:

- Warm the flue with a blowlamp, or similar, for about 10 minutes.
- Place a smoke pellet on the centre of the grate, with the air controls open.
- Close the door. Smoke should now be drawn up the flue and be seen to exit from the flue terminal.
- Complete test with all doors and windows closed in the room where the appliance is fitted.
- If there are any extractor fans in adjacent rooms the test must be repeated with the fans running on maximum and with interconnecting doors open.
- Check the effect of ceiling fans during the test.

If the test fails, re-check the suitability of the flue system and ventilation. An inadequate air supply to the room is potentially dangerous.

- Light the appliance and slowly increase the temperature.
- Ensure no combustion products enter the room.
- Open the main fire door when the appliance reaches operating temperature and carry out a spillage test with a smoke match or pellet around the door opening.

### 1.3 If excessive spillage occurs allow the appliance to cool and re-check the flue system and ventilation.

### 1.4 Finally:

- Explain to the user the safe operation of the appliance, use of the controls and the importance of only using suitable fuels.
- Ensure that a CO alarm has been fitted and make the user aware of its operation and importance, referring them to the Warning section on page 5 of the User Instructions.
- Explain the cleaning and routine maintenance requirements.

- Explain the requirement to use a suitable fireguard when children, elderly or infirm persons are near the appliance.
- Record retailer/supplier and installer details in Appliance Commissioning Checklist (page 3, Instructions for Use).

- Record serial number in Appliance Commissioning Checklist (page 3, Instructions for Use).

This number is required when ordering spare parts and making warranty claims.

- Give this instruction manual to the customer.

# Certificate Of Compliance

Upon completing the installation, the form below must be filled in by your installer to comply with the requirements of HETAS and the building regulations. The installer must give these details, including their HETAS registration number, for the purposes of any insurance details that may change as a result of the appliance being installed.

## HETAS LTD - CERTIFICATE OF COMPLIANCE

PLEASE TICK APPROPRIATE BOXES OR ENTER DETAILS IN BOXES BELOW



Record ID (HETAS Use Only)	<input type="text"/>	(*indicates that this data must be given)
Customer Name	*	
Installation Address	*	
Installation Address		
Installation Address		
Installation Address		
Town	*	
Postcode	*	Work Completion Date *
Local Authority Name (*Must be given if no postcode available)		
Installing Company Name	*	Company's HETAS Reg. No. *
Installing Engineer's Name	*	Engineer's HETAS Reg. No. *

**Description of Work**

**Location:**  
 Lounge  Dining Room  Kitchen  Utility Room  Bedroom  Other, Specify

**Appliance:** Dry Open Fire  Open Fire with Boiler  Dry Cooker  Cooker with Boiler   
 Dry Roomheater/Stove  Roomheater/Stove with Boiler  Independent Boiler   
 Make  Model  Heat Output  kW

**System:** New Heating and Hot Water System  Updated Existing Heating and Hot Water System  Dry System Only

**If Wet System:** Is the Hot Water System Unvented?  Y  N

**Chimney:** New Insulated Factory Made Chimney System Installed

**Relining of existing chimney:** Twin Wall Flexible Liner (for Class 1 Appliance)  Cast In-situ Liner   
 Rigid Sectional Liner Metal  Rigid Sectional Liner Other

**Hearth:** New Hearth/Surround fitted  Existing Hearth Surround Updated

**Additional Information**

**Connecting fluepipe:** Diameter  mm Socket joints upward and gas tight

Provision for sweeping chimney/fluepipe: Yes  No  Chimney Data Plate Location

**Air supply:** Has a permanently open air vent been fitted: Yes  No   
 Is vent opening at least 50% of cross sectional area of throat/flue  or State total free area of air vent  mm<sup>2</sup>

Confirm an approved Carbon Monoxide alarm has been fitted

**Testing & Commissioning to Approved J Appendix E**

Confirm you have commissioned and tested the appliance & associated work for safe and efficient operation

**Declaration of completion** As the competent person responsible for the work described above, I confirm that the appliance and associated work has been installed in accordance with the HETAS rules of registration, and that the work complies with Regulations 4 and 7 of the Building Regulations, and Approved Documents J, G & L as applicable.

Signed: \_\_\_\_\_ Print name: \_\_\_\_\_ Date: \_\_\_\_\_

COPIES OF THIS COMPLETED CERTIFICATE MUST BE (WHITE COPY) SENT TO HETAS LTD AT THE ADDRESS GIVEN BELOW (PINK COPY) GIVEN TO THE CUSTOMER FOR RETENTION (YELLOW COPY) RETAINED BY THE INSTALLING COMPANY

THIS CERTIFICATE SHOULD BE RETAINED BY THE PROPERTY OWNER  
WHO MAY BE REQUIRED TO PRODUCE IT IN ANY FUTURE SALE OF THE PROPERTY.



# Maintenance & Servicing

For a complete list of spare parts and accessories contact your Dovre or call 01392 474011

## 1. Annual Service

- 1.1 Before the start of the heating season strip, inspect and clean the appliance as detailed:
- Allow appliance to cool.
  - Remove all internal parts and, for multi-fuel versions, grate system and ashpan. Take care handling firebricks as they can become fragile after a period of use.
  - Sweep the appliance at this point if necessary.
  - Vacuum clean any remaining ash and debris from the inside of the appliance. Stovax offer a filter/collection attachment for vacuum cleaners to protect them from fire ash: Ash Clean (Part No. 2091).
  - Clean the grate parts (multi-fuel) with a wire brush.
  - Check the parts for any damage. Replace any damaged parts using genuine Dovre replacements parts.
  - Check and clean the firebricks with a soft brush. Some surface damage will occur during use. The life of the bricks will depend on the type of fuels burnt and the level of use. **Replace damaged bricks as soon as possible.**
  - Re-fit cleaned internal parts.
  - **On appliances with printed glass do not use cleaning agents that have a high alkaline or acidic content, for example Stovax Gel Cleaner, these are aggressive cleaning agents designed to be used with heavily stained clear glass. On printed glass surfaces, use Stovax Glass Cleaner (Stovax No.4103) which is better formulated for this application.**
- Do not use abrasive cleaners to remove tar or soot deposits from the glass.**
- Remove the glass from the door and replace all old rope seals.
  - Fit new door rope seal (see *Maintenance and Servicing, Section 5*).
  - Lightly oil the door catch mechanism and hinge pins. Avoid getting oil onto the door seals and glass.
  - To refresh painted finishes a touch up spray is available. Contact your Dovre retailer quoting the serial number found on the appliance data badge.

- 1.2 Use genuine Dovre replacement parts to keep the appliance in safe, efficient working order. This is a list of the maintenance products that may need be required:

Task	Product name
Preventing build-up of creosote in flue	Protector (15 sachets)
	Protector (1kg tub)
Sealing flue pipe joints	Fire Cement (500g tub)
	Fire Cement (600g cartridge)
Re-painting	Touch Up Paint (150ml aerosol)
Protecting your hands	Heat resistant leather gloves
Thermic seal glue	(50ml bottle)
Ash Clean	Vacuum Cleaner Attachment
Cleaning Glass	Gel Cleaner
	Glass Cleaner (Stovax no. 4103)

These products, available online at [www.dovre.co.uk](http://www.dovre.co.uk) or from your local Dovre Retailer, along with regular maintenance and use of correct fuels, will keep the appliance in the best possible condition.

- 1.3 For more information about Dovre products please visit our web site at [www.dovre.co.uk](http://www.dovre.co.uk)
- 1.4 Burn at a low temperature for the first day of use after any maintenance. This allows the seals, fixing glues and paint to fully cure.
- 1.5 During this time the appliance may give off some unpleasant odours. Keep the room well ventilated to avoid a build-up of fumes.
- 1.6 Your Dovre Retailer can carry out service and maintenance.

## 2. Removal of Internal Parts

- 2.1 To service and maintain the good working condition of your appliance it will be necessary to remove several internal parts. Consult the installation section for the following:
- Log Guard** - Pre-Installation Section 2, page 18.
  - Firebricks** - Pre-Installation Section 3, page 18
  - Baffles** - Pre-Installation Section 4, page 18.
  - Riddling Mechanism** - Maintenance & Servicing, Section 3, page 25.

# Maintenance & Servicing

## 3. Removal of the Riddling Mechanism

- 3.1 To maintain good working condition the riddling mechanism can be removed for cleaning.

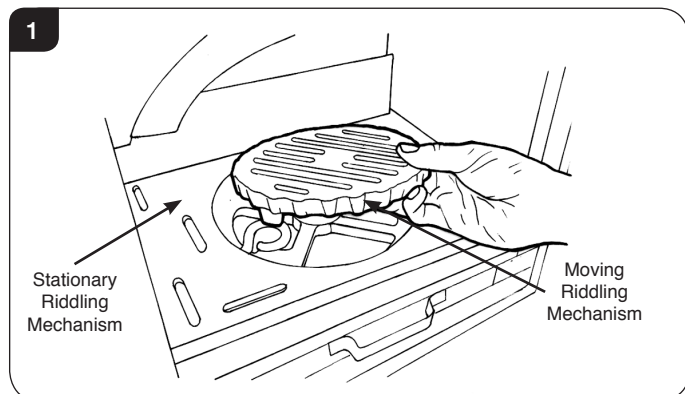

## 4. Fitting a new Door Glass

To maintain safe use of the appliance damaged door glass must be replaced immediately.

To do this:

- 4.1 Remove the door by opening, removing the hinge pins and lifting the door free of the hinge blocks.
- 4.2 Lay the door face down on a soft flat surface to protect the paintwork and glass
- 4.3 Remove the glass clip fixing screws The old glass can then be lifted clear of the door.  
**Note how the 3mm sealing rope is placed between the glass and the door.**
- 4.4 **Dispose of the old glass safely.**
- 4.5 Clean and re-paint the rear of the door if required.
- 4.6 Clean the screws with light oil and coat with high temperature anti-seize grease to aid future removal.
- 4.7 Fit a new sealing rope between the new glass and the door, and place the glass into position in the door.
- 4.8 Place the glass fixing clips into position and re-fix with the clean fixing screws, tightening the screws evenly until glass is held securely.  
  
**Do not over tighten the screws as this could break the glass.**
- 4.9 Fit only original Dovre ceramic glass, which is suitable to use in high temperature applications.
- 4.10 Using the appliance with damaged door glass could cause dangerous fumes to enter the room or the appliance to over-fire resulting in damage.

## 5. Fitting a new Door Seal

To maintain the safe use of the appliance damaged or worn door sealing rope must be replaced.

To do this:

- 5.1 Remove door from appliance by opening, removing the hinge pins and lifting the door free of the hinge blocks.
- 5.2 Lay the door face down on a soft, flat surface to protect the paintwork and glass.
- 5.3 Remove old rope and scrape old glue from locating groove.
- 5.4 Clean the locating groove with a clean, dry cloth to remove all old dust and debris.
- 5.5 Squeeze a generous bead of fresh Thermic Seal glue into the rope locating groove.
- 5.6 Press the new rope into the locating groove, placing the joint in the middle of the lower edge of the door.
- 5.7 Refit door and close to apply pressure to new rope.
- 5.8 Leave the door(s) closed for at least 12 hours before lighting the appliance and run at a low temperature for approximately one day. This allows the adhesive to fully bond to the seal.
- 5.9 Using the appliance with a damaged door seal can cause dangerous fumes to enter the room, or the appliance to over fire resulting in damage.

# Technical Appendix

## Legal Requirements

Before installation and/or use of this appliance please read these instructions carefully to ensure that all requirements are fully understood.

**The appliance must be fitted by a registered installer, or approved by your local building control officer.**

It is very important to understand the requirements of the national Building Regulations and standards, along with any local regulations and working practices that may apply. Should any conflict occur between these instructions and these regulations then the regulations must apply.

Your local Building Control Office can advise regarding the requirements of the regulations.

**i** † England and Wales – Document J / Scotland - Part F/Document J (Republic of Ireland only)  
‡ the latest edition of BS 8303, BS EN 15287, BS 7566

\*Registered on the Competent Persons Scheme (GB only) see page 29/ INFO (Republic of Ireland).

Works must be carried out with care to meet the requirements of Health and Safety and comply with the Health and Safety rules, and any new regulations introduced during the lifetime of these instructions. Particular attention should be drawn to:

- **Handling:** The appliance is heavy. Adequate facilities must be available for loading, unloading and on site handling.
- **Fire Cement:** Some fire cement is caustic and must not come into contact with the skin. Protective gloves must be worn. Wash hands thoroughly with plenty of water after contact with skin.
- **Asbestos:** This appliance contains no asbestos. If there is the possibility of disturbing any asbestos in the course of installation seek specialist guidance and use appropriate equipment.
- **Metal Parts:** Take care when installing or servicing the stove to avoid personal injury.

**A faulty installation can cause danger to the inhabitants and structure of the building.**

### For users of this appliance:

Your building insurance company may require you to inform them that a new heating appliance has been installed on your property. Check that your cover is still valid after installing the appliance.

## 1. Flue Outlet Positions

These positions are defined by Document J of the Building Regulations.

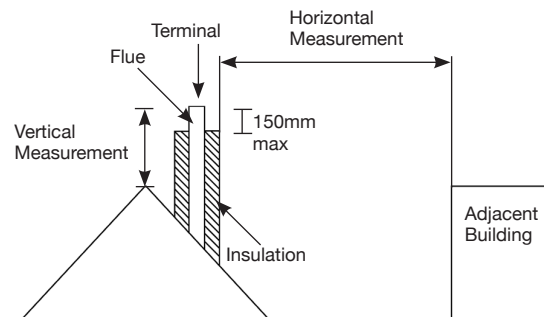
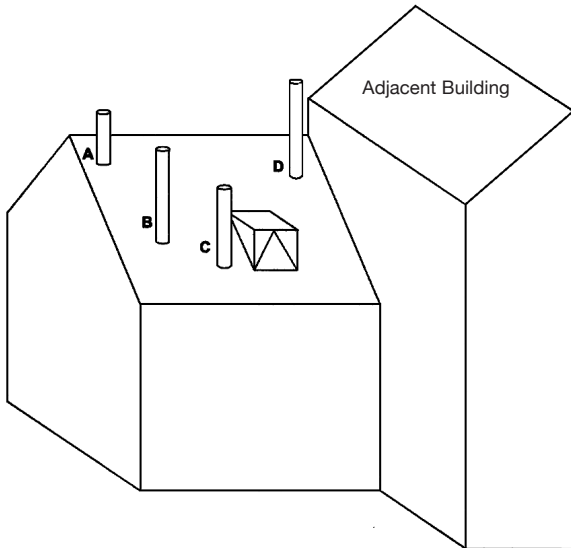

The datum for vertical measurement is the point of discharge of the flue from either the point of discharge of the flue or 150mm above insulation, whichever is the lower.

**IMPORTANT: Seek specialist advice if installing in a dwelling with a thatched roof**

Point where the flue passes through weather surface (Notes 1 & 2)		Clearances to flue outlet
A	At or within 600mm of the ridge	At least 600mm above ridge
B	Elsewhere on roof (whether pitched or flat)	At least 2300mm horizontally from the nearest point on the weather surface and: a) at least 1000mm above highest point of intersection of the chimney with and the weather surface; or b) at least as high as the ridge
C	Below (on a pitched roof) or within 2300mm horizontally to openable rooflight, dormer window, or other opening (Note 3)	At least 1000mm above the top of opening
D	Within 2300mm of an adjoining or adjacent building, whether or not beyond the boundary (Note 3)	At least 600mm above any part of the adjacent of building within 2300mm

1) The weather surface is the building external surface, such as it's roof tiles or external walls.  
2) A flat roof has a pitch less than 10°.  
3) The clearance given for A or B, as appropriate, will also apply.  
4) A vertical flue fixed to an outside wall should be treated as equivalent to an inside flue emerging at the nearest edge of the roof.

# Technical Appendix - Flues

## 2. Flue or Chimney

- 2.1 The flue or chimney system must be in good condition. It must be inspected by a competent person and passed for use with the appliance before installation.

Products of combustion entering the room can cause serious health risks.

- 2.2 The following must be checked:

- The construction of the masonry chimneys, flue block chimneys and connecting flue pipe system must meet the requirements of the Building Regulations†.
- A flexible flue liner system can be used if certified for use with solid fuel systems and installation complies with manufacturer's instructions and Building Regulations. The flue liner must be replaced when an appliance is replaced, unless proven to be recently installed and in good condition.
- If it is necessary to fit a register plate it must conform to the Building Regulations†.
- The minimum height of the flue or chimney must be 4.5m from the hearth to the top of the flue, with no horizontal sections and a maximum of 4 bends. Bends must have angles of less than 45 degrees from the vertical.
- There should be at least 600mm of vertical flue pipe above the appliance before any bends are introduced.
- Ensure the connecting flue pipe is kept a suitable distance from any combustible material and does not form part of the supporting structure of the building.
- The installer must ensure the flue pipe diameter is not less than the diameter of the outlet of the appliance and does not narrow to less than the size of the outlet at any point in the system.
- Make provision to remove the appliance without the need to dismantle the chimney.
- Any existing flue must be confirmed as suitable for the new intended use as defined in the Building Regulations.
- The flue or chimney systems must be inspected and swept to confirm the system is structurally sound and free from obstructions.
- If the chimney is believed to have previously served an open fire it must be swept a second time within a month of regular use after installation to clear any soot falls that may have occurred due to difference in combustion levels.
- The flue exit from the building must comply with local building control rules†.
- Chimney heights and/or separations may need to be increased in particular cases where wind exposure, surrounding tall buildings, high trees or high ground could have adverse effects on flue draught.
- Do not connect or share the flue or chimney system with another heating appliance.

- 2.3 Do not connect to systems containing large voids or spaces over 230mm square.
- 2.4 Suitable access must be provided to enable the collection and removal of debris.
- 2.5 The flue must be swept and inspected when the appliance is installed.

### Flue Draught

The flue draught must be checked with all windows and doors closed and any extraction fans in this, or adjoining rooms, running at maximum speed (see Installation Checklist for ventilation requirements).

## Twin Wall Flue System

If this appliance is to be used in conjunction with a twin wall flue system then Dovre recommend the use of the Stovax Professional XQ range. Details of this product are available from your Dovre retailer.



### In the U.K:

\*BS 15287-1 and the requirements of Building Regulations

\*\*This should be done by a NACS registered (UK only)/INFO registered (Eire only) chimney sweep, who will issue you with a certificate.

### † Building Regulations Document J

#### Flue Plate:

Where a hearth, fireplace, flue or chimney is provided or extended (including cases where a flue is provided as part of refurbishment work), information essential to the correct appliance and use of these should be permanently posted in the building, to meet Requirement J4 of the Building Regulations (England and Wales), F3.12 (Scotland).

#### Additional:

A new factory made system that complies to EN 1856; Part 1 can be used providing installation is to the requirements of:

- i) BS 7566 Parts 1 -4
- ii) the manufacturer's instructions
- iii) Building Regulations.

For a guide containing information on Chimneys and Flues contact:

The British Flue & Chimney Manufacturers' Association,  
FETA  
2 Waltham Court  
Milley Lane  
Hare Hatch  
Reading  
Berkshire RG10 9TH

Tel: 0118 9403416

e-mail: info@feta.co.uk

# Technical Appendix - Ventilation

## 3. Ventilation

- 3.1 Many older buildings are sufficiently ventilated by natural leakage of air to provide suitable air supply for an appliance of 5kW output or less.
- Modern building techniques have reduced the amount of air that leaks in or out of a house. A modern construction with an air tightness of less than 5m<sup>3</sup> per hour per m<sup>2</sup> requires an air vent for **ALL** solid fuel appliances including those with a rated heat output of less than 5kW.
- NOTE: The air leakage of a modern house is tested at the completion of construction and a certificate issued confirming this.
- 3.2 This appliance requires a constant supply of air to maintain proper combustion and effective flue performance.
- 3.3 An inadequate air supply can result in poor combustion and smoke entering the room which is potentially dangerous.
- 3.4 This supply of air can come from either:
- The natural leakage of air into the room in which the product is fitted.
  - Purpose provided ventilation.
  - Some Dovre appliances can also be fitted with an optional outdoor air kit which allows air to be drawn in from the outside.
- 3.5 The amount of air required must comply with local building regulations and the rules in force.
- 3.6 If spillage is detected during commissioning then there may be insufficient natural ventilation and an additional air supply will be necessary.
- 3.7 Permanent air vents should be non-adjustable and positioned where they are unlikely to become blocked.
- 3.8 If vents open into adjoining rooms or spaces there must be an air vent of at least the same size direct to the outside.
- 3.9 Site the vents where cold draught is unlikely to cause discomfort. This can be avoided by placing vents near ceilings or close to the appliance (See diagram).
- 3.10 Extractor fans or cooker hoods must not be placed in the same room or space as this can cause the appliance to emit fumes into the room.
- 3.11 Increase air supply provisions where a room contains multiple appliances.
- 3.12 **If any checks reveal problems do not proceed with the fitting of the appliance until they have been rectified.**

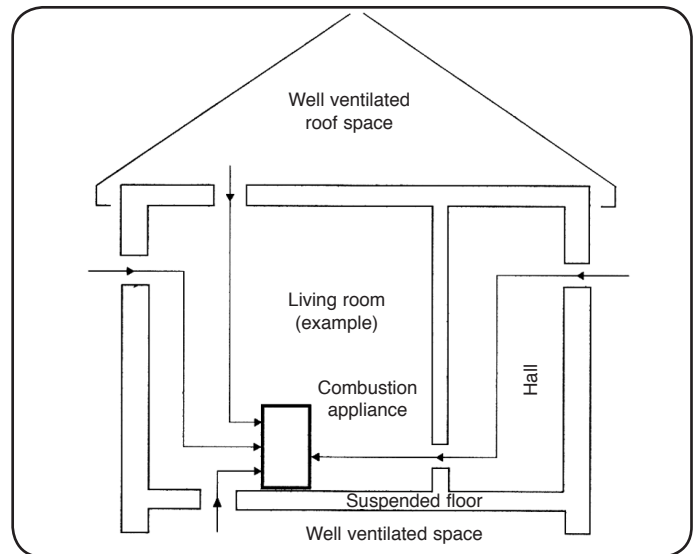

## 4. Minimum Dimensions - Hearth

- 4.1 The appliance must stand on a non-combustible constructional hearth which is at least 125mm thick with the minimum dimensions as shown in diagram. As this appliance can be installed in an elevated setting it is recommended to increase the 225mm hearth depth to safely contain any falling logs or embers. The higher the appliance is installed the deeper the hearth should be to protect the floor.
- 4.2 The building must have a suitable load-bearing capacity for the hearth and appliance. Consult a structural engineer for advice before proceeding.
- 4.3 When fitting into an existing hearth check that the appliance complies with current construction regulations and is at least the minimum sizes shown.
- 4.4 If there is no existing fireplace or chimney it is possible to construct a suitable non-combustible housing and hearth setting. The flue must be installed in accordance with all local and national regulations and current rules in force.
- 4.5 Check if adding a new chimney to your property requires planning permission.
- 4.6 Some houses are built using a timber frame construction with high levels of thermal insulation. Isolate the appliance from combustible materials, and provide sufficient ventilation to maintain the heating efficiency.

# Technical Appendix - Ventilation

## 5. Fitting Appliances On A Boat

- 5.1 If an appliance is to be fitted in a boat it must be done in accordance with the latest edition of BS 8511 (Code of Practice for the Installation of Solid Fuel Heating Appliances on Boats). The Code covers the design, installation and operation of solid fuel heating appliances that are suitable for fitting into inland waterway boats, and gives guidance on product selection, design considerations, installation requirements, inspection and testing, as well as maintenance and safe use tips.
- 5.2 Consideration should also be given to the requirements of the Boat Safety Scheme (BSS) to ensure the boat's insurance remains valid.
- 5.3 The appliance should only be installed by a competent person with experience of the latest edition of BS 8511 and the Boat Safety Scheme (BSS).
- 5.4 Secure the product to a suitably constructed non-combustible hearth.
- 5.5 All open flued appliances can be affected by temporary atmospheric conditions which may allow fumes to enter the boat. An electronic carbon monoxide detector conforming to the latest edition of BSEN50292 must be fitted and maintained.
- 5.6 Failure to safely install the appliance could endanger the boat and persons on board.



### Organisations authorised to certify competence in the installation of domestic solid fuel appliances (Competent Persons Scheme):

APHC - Association of Plumbing and Heating Contractors (Certification) Ltd.  
[www.aphc.co.uk](http://www.aphc.co.uk)

BESCA - Building Engineering Services Competence Accreditation Ltd.  
[www.besca.org.uk](http://www.besca.org.uk)

HETAS - Heating Equipment Testing and Approval Scheme Ltd.  
[www.hetas.co.uk](http://www.hetas.co.uk)

NAPIT - National Association of Professional Inspectors and Testers Ltd.  
[www.napit.org.uk](http://www.napit.org.uk)

NICEIC - NICEIC Group Ltd.  
[www.niceic.org.uk](http://www.niceic.org.uk)

### HETAS Approved Chimney Sweeps:

NACS - The National Association of Chimney Sweeps  
[www.chimneyworks.co.uk](http://www.chimneyworks.co.uk)

APICS - The Association of Master Chimney Sweeps Ltd.  
[www.apics.org](http://www.apics.org)

The Guild of Master Chimney Sweeps -  
[guildofmasterchimneysweeps.co.uk](http://guildofmasterchimneysweeps.co.uk)



# Basic Spare Parts

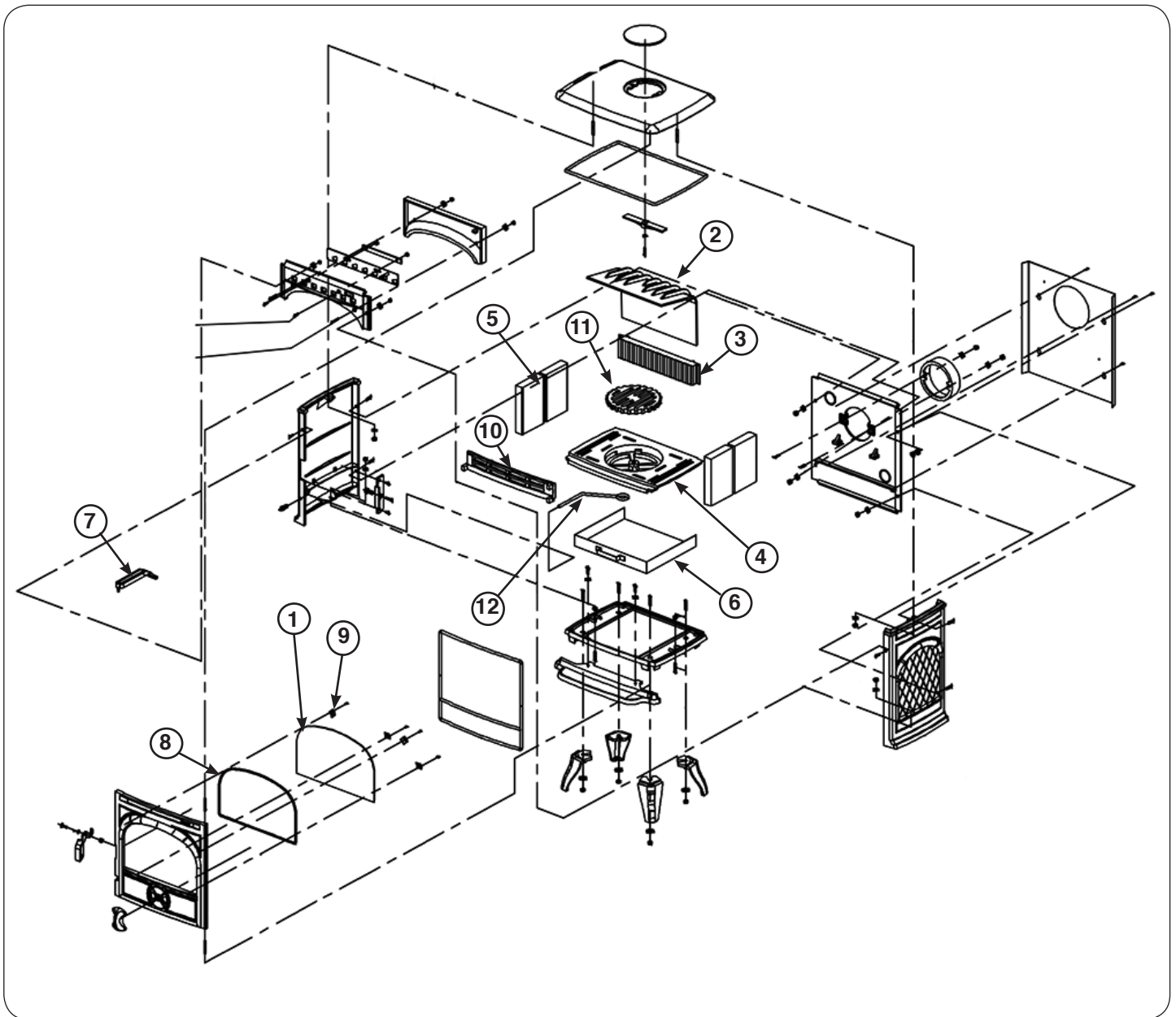

Ref. No.	Description
1	DOOR GLASS
2	BAFFLE
3	INNER BACK PLATE
4	GRATE HOLDER
5	SIDE FIREBRICK
6	ASHPAN
7	ASHPAN HANDLE
8	GLASS RETAINER
9	GLASS RETAINER SCREW
10	LOG RETAINER
11	CENTRE GRATE
12	RIDDLING ROD

# Service Records

## 1ST SERVICE

Date of Service:.....

Next Service Due:.....

Signed:.....

Dealer's Stamp/HETAS Registration Number

## 3RD SERVICE

Date of Service:.....

Next Service Due:.....

Signed:.....

Dealer's Stamp/HETAS Registration Number

## 5TH SERVICE

Date of Service:.....

Next Service Due:.....

Signed:.....

Dealer's Stamp/HETAS Registration Number

## 7TH SERVICE

Date of Service:.....

Next Service Due:.....

Signed:.....

Dealer's Stamp/HETAS Registration Number

## 9TH SERVICE

Date of Service:.....

Next Service Due:.....

Signed:.....

Dealer's Stamp/HETAS Registration Number

## 2ND SERVICE

Date of Service:.....

Next Service Due:.....

Signed:.....

Dealer's Stamp/HETAS Registration Number

## 4TH SERVICE

Date of Service:.....

Next Service Due:.....

Signed:.....

Dealer's Stamp/HETAS Registration Number

## 6TH SERVICE

Date of Service:.....

Next Service Due:.....

Signed:.....

Dealer's Stamp/HETAS Registration Number

## 8TH SERVICE

Date of Service:.....

Next Service Due:.....

Signed:.....

Dealer's Stamp/HETAS Registration Number

## 10TH SERVICE

Date of Service:.....

Next Service Due:.....

Signed:.....

Dealer's Stamp/HETAS Registration Number

CE-conformiteitsverklaring  
Declaration de conformité CE  
EC Declaration of conformity  
Konformitätserklärung CE



Notified body: 1641

Wij,  
Nous,  
We,  
Wir,

Dovre nv, Nijverheidsstraat 18, B2381 Weelde,

verklaren bij deze dat de kachel 250 conform is volgens de EN 13240.  
déclarons que le poêle 250 est conforme au norme EN 13240.  
declare that the stove 250 est in conformity with the EN 13240.  
Erklären daß das Produkt 250 entspricht EN 13240.

Weelde, .09.01.2006

T. Gehem

A handwritten signature in black ink, appearing to be "T. Gehem", written over a vertical line that serves as a signature separator.

## The Clean Air Act 1993 and Smoke Control Areas

Under the Clean Air Act local authorities may declare the whole or part of the district of the authority to be a smoke control area. It is an offence to emit smoke from a chimney of a building, from a furnace or from any fixed boiler if located in a designated smoke control area. It is also an offence to acquire an “unauthorised fuel” for use within a smoke control area unless it is used in an “exempt” appliance (“exempted” from the controls which generally apply in the smoke control area).

The Secretary of State for Environment, Food and Rural Affairs has powers under the Act to authorise smokeless fuels or exempt appliances for use in smoke control areas in England. In Scotland and Wales this power rests with Ministers in the devolved administrations for those countries. Separate legislation, the Clean Air (Northern Ireland) Order 1981, applies in Northern Ireland. Therefore it is a requirement that fuels burnt or obtained for use in smoke control areas have been “authorised” in Regulations and that appliances used to burn solid fuel in those areas (other than “authorised” fuels) have been exempted by an Order made and signed by the Secretary of State or Minister in the devolved administrations.

Further information on the requirements of the Clean Air Act can be found here: <http://smokecontrol.defra.gov.uk/>

Your local authority is responsible for implementing the Clean Air Act 1993 including designation and supervision of smoke control areas and you can contact them for details of Clean Air Act requirements”

The Dovre 250 (DV-250) has been recommended as suitable for use in smoke control areas when burning dry wood logs when suitable permanent stops have been fitted and when operated in accordance with the manufacturer’s instructions.









### **HETAS Approval**

These appliances have been approved by HETAS as an intermittent operating appliance for burning dry seasoned wood logs or manufactured briquette smokeless fuels.

### **Recommended Fuels**

Please note that HETAS Appliance Approval only covers the use of dry seasoned wood logs or manufactured briquette smokeless fuels on these appliances. HETAS approval does not cover the use of other fuels either alone or mixed with the recommended fuels, nor does it cover instructions for the use of other fuels.



United Kingdom and Eire distributors for Dovre:

**STOVAX**

Stovax Limited, Falcon Road, Sowton Industrial Estate, Exeter, Devon, England, EX2 7LF.

Telephone: (01392) 474011 Fax: (01392) 219932

E-mail: [dovre@stovax.com](mailto:dovre@stovax.com) Internet: [www.dovre.co.uk](http://www.dovre.co.uk)

E & O E