



SUPPLY & FABRIC REQUIREMENTS

- 1 Fat Quarter Fabric for Toes
- 1 10" x 12" Rectangle for the Heels
- 17" length of 1/4" elastic
- 20" x 20" Square of thin Batting
- 1 Fat Quarter Fabric of Toe and Sole Linings
- 12" x 14" Sole Fabric (*We used Felted Wool.*)
- 1 pair Double Thick Insoles (*These can be purchased at the drug store and cut to fit.*)
- 1 pkg. Wrap 'n Fuse Piping for Stem Art No. 9512
- 1 Round "Quick" Yo-yo Maker XS Art No. 8702

SLIPPERS

The slippers in this pattern will fit Women's medium to large sizes. You may also purchase a pair of black velvet slippers and embellish them with a stem, and the yoyos. Or knit a pair and felt them down, then decorate.

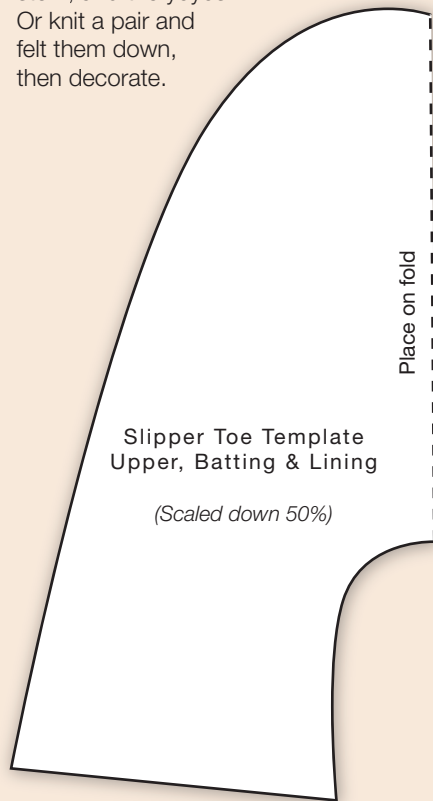

Slipper Toe Template
Upper, Batting & Lining

(Scaled down 50%)

Place on fold

Oval Yo-Yo Slipper Side and Sole Lining

(Scaled down 50%)

Cutting

- For Heel: Cut 2 rectangles each 6" x 9 1/2" from the Heel Fabric
- Cut 2 rectangles each 6" x 9 1/2" from the Batting
- Cut 2 pieces of 1/4" elastic each 8 1/2"
- For Toe: Cut 2 each from the Toe Fabric, Batting and Lining following the toe pattern
- For Sole: Cut 2 each from the Sole Lining and Sole Fabric following the sole pattern
- For Embellishment:
Stem: Cut 2 bias strips each 1" x 8" & 2 Wrap 'n Fuse Piping at 8" each
- Flowers: Make 12 extra small yoyos

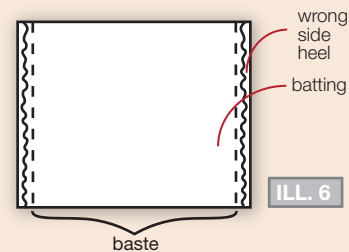

ILL. 6

DIRECTIONS

Sewing

Heel Section

1. Baste batting to wrong side of each heel piece on the short ends (Ill. 6)
2. With wrong sides together fold heel piece in half and press to establish a center fold. Open heel piece and draw a line down the centerfold.

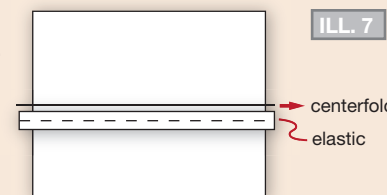

ILL. 7

3. Place the 1/4" wide elastic to one side of the centerfold. The elastic is 1" shorter than the heel piece...so as you stitch, gently pull on the elastic. This will create a soft gather for heel shaping. Set aside. (Ill. 7)

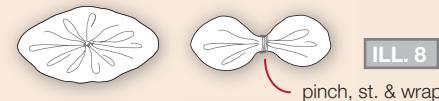

ILL. 8

Toe Section

1. Baste batting to wrong side of toe piece.
2. Create the stem, leaves, and flowers into a pleasing design or follow our layout.

- a. Stem: Wrap 'n Fuse the 2 lengths of piping.
- b. Leaves: Make 2 oval yoyos. Pinch each yo-yo in the middle stitch, wrap and tie off. (Ill. 8)
- c. Flowers: Using scraps, make 12 extra small yo-yos.
- d. Place the Oval yoyo leaves; then set the piped stem over the leaf centers. Stitch down the center of the stem through the toe and batting layers. Then add each small yoyo. (Ill. 9)

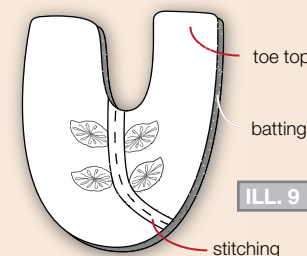

ILL. 9

3. Place the toe lining right sides together over the toe top; stitch around the inner curve only. Clip, turn, and press the lining to the back.

Joining the Heel to the Toe

Open the heel section and the toe/lining section and set them right sides together; stitch the side seams; then turn linings to inside. (Ill. 10)

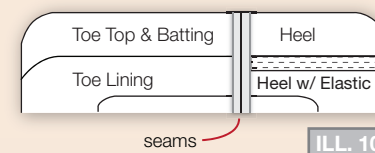

ILL. 10

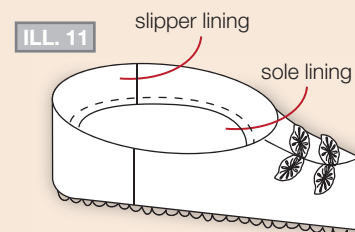

ILL. 11

Sole Lining, Sole & Insole

1. With right sides together stitch the sole lining to the slipper top lining only. (Ill. 11)
2. With right sides together stitch the sole to the slipper, leaving an opening for turning. Turn.
3. Trim the insole to fit the sole of the slipper. Insert the insole between the sole and sole lining through the opening. Stitch opening closed.



Clover

FREE
PROJECTS

COLOR SPLASH YOUR HOME



A QUILT, AN ACCENT
PILLOW AND SLIPPERS



CLOVER NEEDLECRAFT, INC.
Cerritos, CA 90703-2315 U.S.A. www.clover-usa.com
TOLL-FREE: (800) 233-1703 FAX: (562) 282-0220



CT0080
APRIL 2010

make-it

more project ideas available at www.clover-usa.com

with OVAL SHAPE
"QUICK" YO-YO MAKER



COLOR SPLASH YOUR HOME

Oval yo-yos when set together in threes create a circle. These circles make a beautiful design when connected. Mounting colorful yo-yo's on black fabric creates a dramatic effect that's sure to on your liven up your home decor. Use Clover's new Oval Shape Yo-Yo Maker, gather your colors and let's get started on your own splash of color.

OVAL SHAPE "QUICK" YO-YO MAKER
Art. No. 8709



QUILT

Use this beautiful quilt as a wall hanging to bring life to your living room.

SUPPLY & FABRIC REQUIREMENTS

- 1 ¾ yd. Quilt Top
- 1 ¾ yd. Backing
- 37" x 60" Batting
- 24 assorted Fabrics for the Oval Yo-yo's
- 1-2 Fat quarters per color*

*Note: It is possible to get 9 Oval Yo-yo's out of 1 Fat Quarter which is enough for three circles. We picked colors in jewel tones and used four values (dark to light) per color.



Finished Quilt Size Mounted: 35 ¼" x 57 ¾"

DIRECTIONS

Making the Oval Yo-yos We used 6 color families and 4 values per family. For each family we made 4 Circles of Oval Yo-yos for values 1-3 and one circle for the 4th and lightest value. Four circles require 12 Oval yo-yos of the same color. One circle requires 3 Oval yo-yos of the same color.

Note: You may end up with a different color scheme so for this quilt 84 circles were used which means we made 252 Oval yoyos in all!

Joining Yo-yos into Circles Match each yoyo up with right sides together, measure approximately ½" down from the point, then whip stitch for about ½" do this using 3 yoyos forming the circle. (Ill. 1)

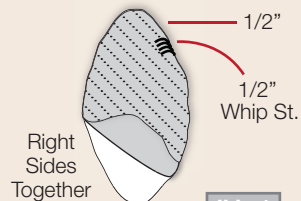

ILL. 1

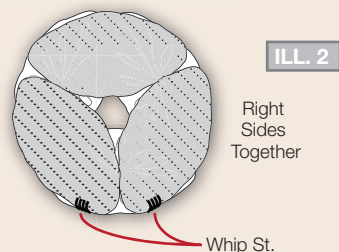
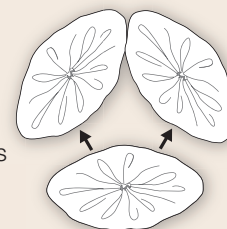

ILL. 2



Joining Circles into Strips Match the circles with right sides together, then stitch the bottom 2 points to the center of the single yoyo. (Ill. 2)

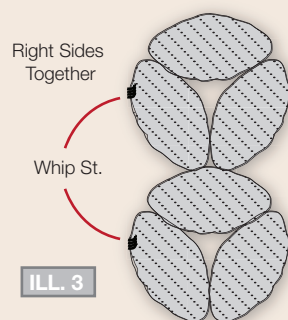

ILL. 3

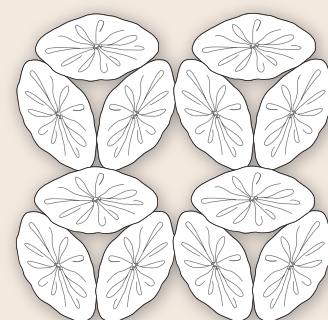

Joining Strips into the Quilt Match each strip, circle to circle with right sides together, pin at the point where the 2 side yoyos meet, then stitch approximately ½" down from the points. (Ill. 3)

Making the Back Quilt

Cut the fabric for the quilt top, batting, and backing each 37" x 59 ½". Layer the backing right sides together to the quilt top and batting. Stitch all the way around leaving an opening for turning. Turn to the right side bring out the corners and press. Press the raw edges of the opening to the inside and stitch closed.

Mounting the Yo-yo quilt into the Back Quilt

Set the yoyo quilt on the Back Quilt making sure there is an even distance on both sides and the top and bottom. This will make the border. Pin the yoyos in place and stitch the yoyo quilt on to the back quilt going through the centers of each yoyo to the back of the quilt. This will hold the quilt together and make the yoyos very stable.



PILLOW

A matching accent pillow brings an elegant touch to any room. Finished size 16" x 16".

SUPPLY & FABRIC REQUIREMENTS

- 16" x 16" Pillow Form
- 1 yd. Fabric for pillow and piping
- 9 assorted Fabrics for the Oval Yoyos*
- 1 pkg. Wrap 'n Fuse Piping Art No. 9517

DIRECTIONS

Cutting

Pillow top: cut a 16" x 16" square
Pillow back: cut 1 rectangle 11" x 16" and 1 rectangle 10" x 16"
Bias strip for piping: 2 ¼" x 60"....this length may need to be pieced.
60" of Wrap 'n Fuse Piping

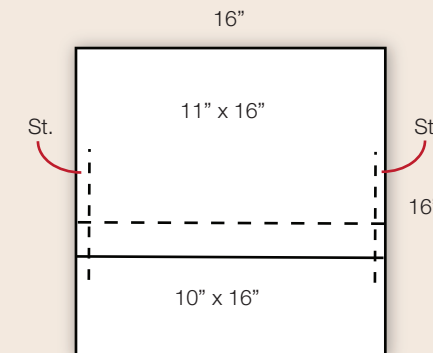

ILL. 4

Sewing

For Pillow Back

On one long side of the smaller rectangle make a ½" hem. Stitch.
On one long side of the larger rectangle make turn under ¼" and press; then fold again making a 1" hem. Stitch.
Place the larger rectangle over the hem of the smaller rectangle and adjust the length so the two pieces create a 16" x 16" square. (Ill. 4)

ILL. 5

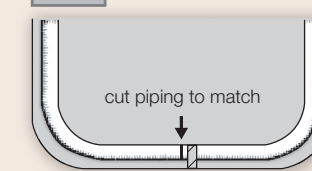

fold raw edges of bias in & continue stitching strip

For the Piping

Wrap 'n Fuse the bias strip to the 60" of Piping. Stitch the raw edges of the piping to the raw edges of the pillow top and join by cutting the piping so it exactly matches to the beginning pipe and covering the beginning cord with the raw edges turned in on the bias strip. (Ill. 5)

Assembly

With right sides together stitch the pillow top to the back. Turn the pillow right side out and stuff the pillow form inside. Lay the 9 connected Oval Yoyo circles on the top of the pillow and adjust for even spacing all the way around the pillow top; pin in place. Remove the pillow form and tack the yoyos in place through the center of each yoyo to the back of the pillow top. Replace the pillow form and it's done!