

Who we are

- SimPure® is a purification brand based in the United States, focusing on engineering filtration and advanced purification technologies.
- SimPure® promotes the philosophy of a minimalist lifestyle, returning to nature with clean water and fresh air.
- SimPure® designs products to be both smart, easy to operate, and practical in appearance and functionality.

Contact Us

If you require technical assistance, please contact our friendly professional support engineers, who will be pleased to assist you.

4530 B STREET NW #A
AUBURN WA 98001

Customer Service: service@simpurelife.com
Toll-Free :1-866-528-4572 (7AM-7PM PDT)
Website: www.simpurelife.com

Y9 Series



SimPure®
— stay simple, stay pure —

Water Filtration System

Model: Y9 Series(Y9T,Y9A)

Retain owner's manual for future reference

SimPure®
— stay simple, stay pure —

4530 B STREET NW #A
AUBURN WA 98001

REGISTER AND EXTENDED ONE YEAR WARRANTY

Please register your items within 30 days of your purchase at

🔍 Simpurelife.com/pages/warranty-registration

or scan the following QR code



Note: All SimPure® products come with a 1-year warranty from the date of purchase. Follow the steps above to register and enjoy an extra year of product warranty-that’s double the peace of mind !

Table of Contents

Register Warranty.....	1
Table of Contents.....	2
Warning & Caution.....	3
Operating Guidelines.....	4
Installation Guide	5
System Features	6
Control and Display Panel.....	7
Connecting up the System.....	8
Internal Flushing & System Flushing.....	9
Dispensing Purified Water.....	11
Operation Guide.....	12
Display Indicators.....	12
Filter Replacement.....	15
Replacement Filter Part Number.....	17
System Maintenance.....	18
Trouble Shooting Guide.....	23
Warranty.....	25
Our Products and Services.....	26

Warning & Caution

SimPure® products are designed with safety in mind. However, personnel using these units must be familiar with any potential dangers. All safety information detailed in this handbook should be reviewed before installing and operating this water purification system.

This product is not a toy; please keep children away from the water purifier or use under adult supervision. Please keep packing materials out of children's reach.

Thorough flushing of the unit is required at start-up and when filters are replaced (flushing instructions on page 9 of manual). The purpose of the flushing is to remove protective liquid (Food-Grade Glycerin) in the RO membrane and the dust in the shipping process.

The system has been designed for indoor use only. Install the system out of direct sunlight on a flat, level, dry, and secure surface in ambient room temperature.

Do not move the system without first isolating the power supply and draining the feed water tank.

This unit is used for the cold municipal tap water or potable well water that has been tested safe by a certified laboratory. Never use hot water or unknown/unsafe sources of water.

The installation of the system must comply with your local and state regulations. Please check before commencing installation.

In case of malfunction, isolate the water supply to the system, If any part of the system is damaged or missing, replace the item before use.

Warnings and Cautions are provided; Failing to observe the instructions could result in damage to the equipment, associated parts, surroundings, or personal injury.

Operating Guidelines

The following table lists the operating parameters for this product. Operating this product outside these specifications may cause system performance issues and may even lead to personal injury and void any warranty. Please contact SimPure® for further advice and support if unsure about the requirements.

Operating Parameters	
Model	SimPure® Y9T & Y9A (Y9 Series)
Difference	Y9T, the third stage filter is T33 Filter, post composite activated carbon filter
	Y9A, the third stage filter is ALK Filter, PH and ALK adjustment filter
Flow Rate(up to) Dependent on feed water and temp	300 Gallons per day (26 oz/min)
Filter Life Expectancy Dependent on feed water and temp	792 Gallons (3000L)
Feed Water Type	Municipal potable/tap water or well water Meeting Government Drinking Water Standards
Feed Water Temperature	41-100°F(5-38°C)
Rated Voltage	110V 60Hz AC
Rated Power	62W
Dimensions	10×15.9×14.3 Inch (253×404×364mm)
Weight	16.5lb (7.5kg)
Storage Reservoirs	1.3 gallons feed water tank
Feed Water TDS* Level	< 500 ppm

IMPORTANT: If the Feed Water Type is not within the above standards (government drinking water standards, TDS<500 ppm), the filter may be easily clogged. Please follow the steps of Page18 to maintain the machine.

Installation guide

System Contents

Your SimPure® Y9 Countertop Water Purification System was carefully assembled, packaged, and shipped completely with all the parts you should require to get the system up and running.

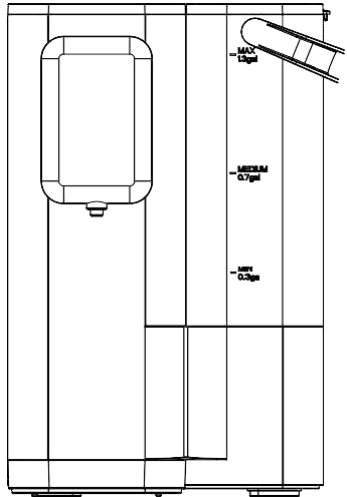

Y9 System
(Include 1.3-Gal feed water tank)



Drip tray



Wrench socket

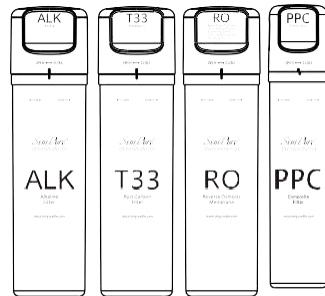

Filters (Pre-installed)
(T33 only for Y9T, ALK only for Y9A)

Unsure about something? Is there a problem?
Please contact SimPure® through our website or toll-free number.

Customer Service: service@simpurelife.com

Toll-Free: +1-866-528-4572

Website: www.simpurelife.com

System Features

SimPure Y9 Series Water Purifier is an instant filtration system.

Compact design, no plumbing required, simply plug the SimPure Y9 system into an electrical outlet and fill with potable(tap) water to be purified.

When you press the Dispense Button, the system instantly filters and dispenses pure water to you, eliminating any wait time.

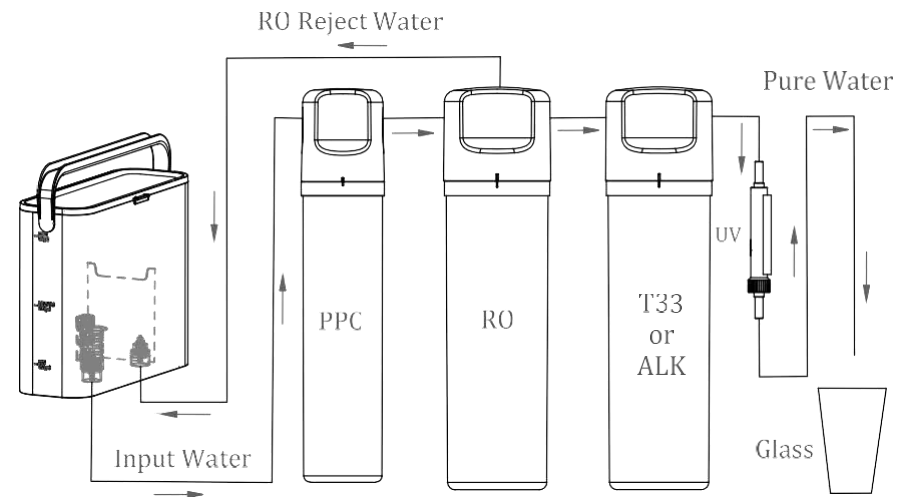

Control and Display Panel

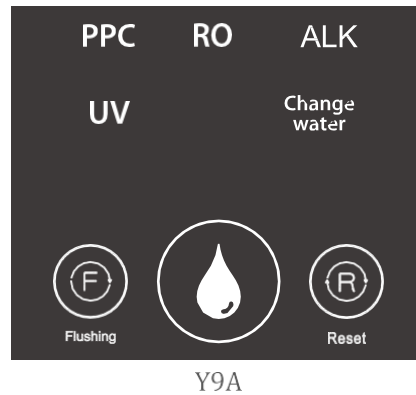
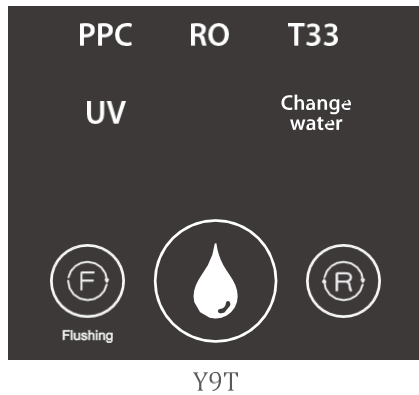

PPC/RO/T33/ALK

When the filter expires, the corresponding indicator of the filter will flash. The T33 filter is only for Y9T, and the ALK filter is only for Y9A.

UV (UV wavelength range: 270~280nm, UV dose: 8600 μ J/cm²)

The UV indicator light is on to indicate that the Ultraviolet light is operating.

Change Water

Indicates the Feed Water Tank contents must be emptied and refilled.

Flushing

Indicates the system is flushing.

Reset

Reset the filter after replacing the cartridges.



- Dispense Button

Press the Dispense Button to start the system, indicated by 1-beep. It will filter and dispense pure water directly to you without any wait time. Press again to stop.

Connecting up the System

Step 01

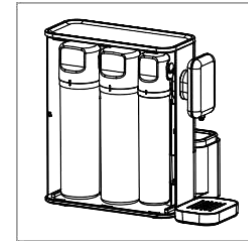

Unpacking- Choose a suitable countertop, flat, secure, and out of easy reaching of small children. Place the drip tray under the outlet. Open the feed water tank cover and lift out the water tank. The system is already pre-installed with the filter cartridges for your convenience.

Step 02

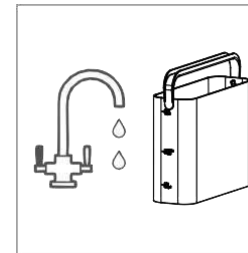

Fill water tank- Firstly, rinse the tank with water; then fill it with potable (tap) water. Please carefully fit the feed water tank into the base of the system, making sure the tank is installed correctly, or the system will not operate. When refilling the tank, always EMPTY the remaining water before refilling. DO NOT exceed the MAX level.

Step 03

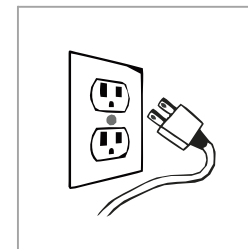

Turn the system on- Plug into an electrical outlet. All indicator lights will be on and flashing twice. You will hear 2-beeps. All indicators and light rings will be lit when the system is turned on.

IMPORTANT:

TO ENSURE BETTER TASTING FRESH WATER AND TO EXTEND THE FILTER CARTRIDGE LIFE. IT'S RECOMMENDED TO EMPTY AND REFILL THE FEED TANK WATER ON A REGULAR BASIS (ONCE A DAY).

Notes:

There is no power switch; unplug device should you need to turn it off.

Internal Flushing and System Flushing

If you are commissioning the system for the first time or have just replaced the filter cartridges, please flush your system for **3-5 TIMES** with the below steps.

Step 01

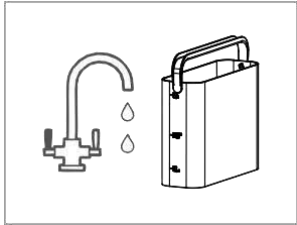

Always start the system flushing with a new tank of potable (tap) water. Carefully fit the feed water tank back into the tank base and close the cover.

Step 02

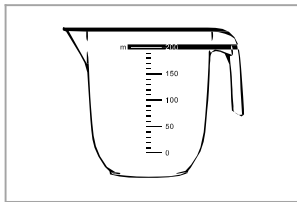

Place a large container on the drip tray and have another container ready to alternate.

Step 03

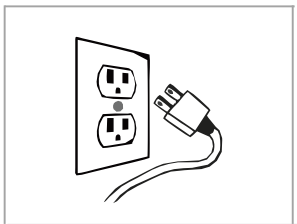

Plug it in, the system will automatically initiate internal flushing for 30 seconds before stopping. Press Flushing Button to stop.

NOTE: The internal flushing is cyclic flushing. The flushed water will be returned to the feed water tank with no water out from the water spout.

Step 04

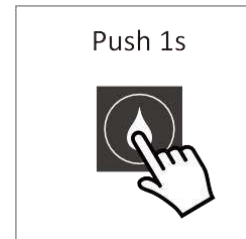

Press the Dispense Button and you will hear a beep. The system will continuously filter and start to dispense the pure water until the feed water tank reaches the minimum water level. (Simply press again to stop)

NOTE: When the new system starts to filter for the first time, it will take about 30s to fill the filter cartridges. Afterward it will dispense pure water immediately.

Step 05

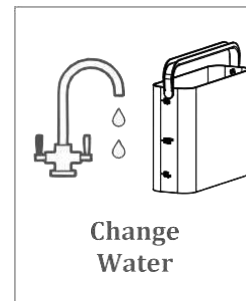

When the water tank reaches the minimum water level, the "Change Water" indicator will light up, indicating that it is time to empty the remaining water in the feed water tank and refill it.

NOTE: In order to extend the service life and maintenance intervals, it is important to always discard the remaining water in the feed water tank and **DO NOT** re-use it for another round of filtering.

Step 06

To complete STEP 4 to 5, you have completed the first round of flushing. Please flush the system for MINIMUM 3 TIMES to complete the initial flushing process.

NOTE:

1. The water supply may be different depending on your feed water source and quality. Thus, please adjust the frequency of flushing it accordingly.
2. When a new system appears to have cloudy particles, foams, air bubbles or poor smell, please do not worry. This is the protective liquid (Food-Grade Glycerin) in the RO filter cartridge, and it will disappear after flushing.

Dispensing Purified Water

Step 01

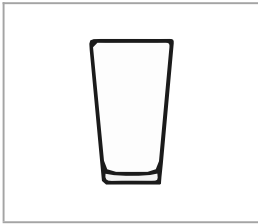

Place a glass or cup on the drip tray of the system under the dispense nozzle.

Step 02

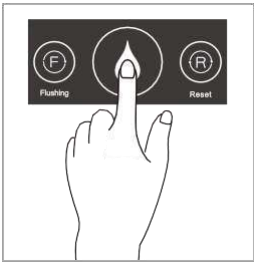

Press the Dispense Button to start the system, indicated by 1-beep. It will filter and dispense pure water directly to you without any wait time. Press again to stop.

CONGRATULATIONS!

You have completed the installation!

IMPORTANT:

ALWAYS FULLY EMPTY THE Y9 FEED WATER TANK BEFORE REFILLING WITH FRESH POTABLE (TAP) WATER, DO NOT TRY TO REFILL THE TANK MOUNTED ON THE SYSTEM (ALWAYS REMOVE IT FIRST).

Operational Guide

Display Indicators

Your SimPure® Y9 Countertop Water Purification System uses advanced features to monitor and operate your system.

Sleep Mode

If there's no operation within 5 minutes, the system will enter into sleep mode(standby mode). Then the brightness of the Dispense Button ring will decrease, and other indicators will go out.

Pressing the Dispense Button to exit the standby mode, the indicators will display normally, and press the button again to activate the corresponding function.

PPC/RO/T33 (or ALK) Indicator Light

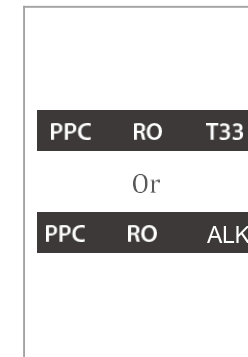

The three indicator lights remind the user to replace the filters;

Steady- After power on, all filter indicator lights will remain on.

Flashing- The filter has expired, indicated by 3-beeps. Please replace the corresponding filter.

PPC = Composite Filter

RO = Reverse osmosis filter cartridge

T33 = Composite activated carbon filter, Only for Y9T

ALK = PH and ALK adjustment filter, Only for Y9A

All Indicator Lights

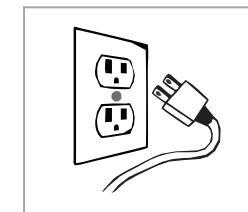

Safety Protection

If the system continues to filter water for 10 minutes, the system will enter into the protection mode. The system will stop filtering and dispensing water, indicated by 3-beep and all indicators flashing. Reset the System by reconnecting the power.

Flushing Indicator Light & Button



Automatic
flushing

Automatic internal flushing

The system will automatically initiate internal flushing in the following situations:

1. Plug it in, the system will automatically initiate internal flushing for 30 seconds. While flushing, the indicator light will be on.
2. The system will automatically initiate internal flushing for 8 seconds after stopping dispense water. While flushing, the indicator light will be on.

Push 1s



Manual flushing

Manual internal flushing - Press the Flushing button to activate it, indicated by 1-beep, the Flushing button will be on. The system will initiate internal flushing for the 30 seconds.

Enhanced manual internal flushing - Press and hold the Flushing button for 3 seconds to activate it, indicated by 1-beep. The system will initiate internal flushing for 5 minutes before automatically stopping. Press the Flushing button again to stop the process.

Hold 3s



Enhanced
manual flushing

IMPORTANT- Daily or weekly manual internal flushing (Enhanced manual internal flushing) can extend the life of the filter cartridges.

Note - The internal flushing is cyclic flushing where the flushed water returns to the feed water tank for circulation. This process does not affect the quality of the purified water after filtering, and no water will flow out from the water outlet.

UV Indicator Light

UV



Light on- When the system filters and dispenses water, the UV indicator light turns on. Enabling the UV to continuously control microbes in the purified water.

Light off- When the system stops filtering and dispensing water, the UV light turns off, indicating that the UV has stopped operating.

Change Water Indicator Light

Change
Water

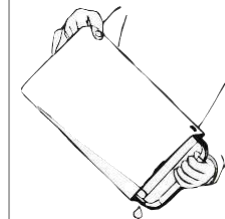

With 3 beeps and light is on - Indicates the feed water tank needs to be emptied and refilled. If the water level in the tank is lower than the minimal level, the system will stop filtering, indicated by 3-beeps and the Change Water indicator will be on. Please remove the feed water tank, empty ALL the remaining water, and refill with fresh potable (tap) water. Refit the Feed Water Tank to the System.

Steady - Feed water tank has been removed from the base. The steady light will go off once the full tank is back in the place.

IMPORTANT- In order to extend the service life and maintenance intervals, it is important to always discard the remaining water in the feed water tank and DO NOT re-use it for another round of filtering.

Filter Replacement

Step 01

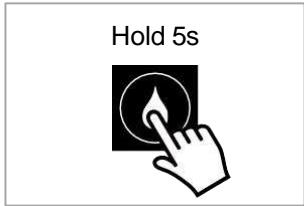

Drain the filter cartridges

- ① Remove the water tank from the system, and then place a container on the drip tray.
- ② Press and hold the Dispense Button for 5 seconds to dispense the remaining water from the filter cartridges (about 17oz). It will stop after five minutes and the Dispense Button light will go out.

Note: Failure to do the above steps before removing the filter cartridges may cause water leakage.

Step 02

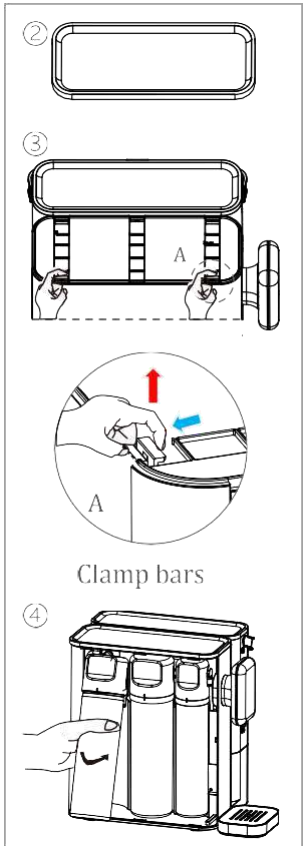

Remove the filter cartridges

- ① Unplug the power supply.
 - ② Open the upper cover of the system.
 - ③ Pull the two clamp bars on the side cover towards the blue arrow and then lift the side cover up along the red arrow until it opens.
- Note:** See Figure A for the operation of the two clamp bars.
- ④ Lift the filter cartridge from the bottom towards yourself, twist it counterclockwise to remove it. Insert the new filter cartridge in the correct position and twist it clockwise until you feel a click.
 - ⑤ Follow the disassembly method to install the side cover and the upper cover.

Note: You can safely dispose of the exhausted cartridge.

Step 03

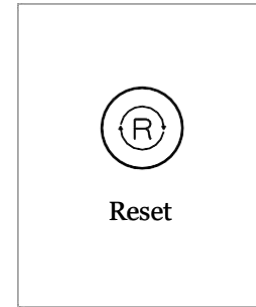

Reset the filter

Plug the system back into an electrical outlet. Now we need to reset the filter indicator.

Situation 1

When the indicator is flashing, replace the filter and reset it by pressing and holding the "Reset" button for 3 seconds. The indicator will remain steady with 3 beeps to reset successfully.

Note: the above steps can reset all flashing filter indicators at once.

Step 04

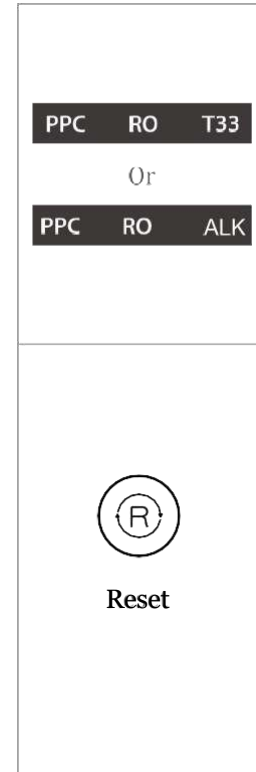

Situation 2

When the filter needs to be replaced in advance (Indicator is not flashing) because of the decreased flow, odor and etc, follow these steps to reset the filter after replacing it.

- ① Press and hold the Reset button for 3 seconds to enter the system progress selection mode. (Select the filter indicator to be reset).
- ② You will hear 1-beep, the default selection is the PPC indicator, indicated by flashing light.
- ③ To choose another filter indicator (RO/T33/ALK), by simply pressing the Reset button to cycle through the options. The selected filter indicator will flash.
- ④ Press and hold the Reset button for at least 3 seconds to complete the reset process, the selected filter indicator will remain steady indicated by 3-beep. The system will return to regular operation.

Note:

1. The above steps can only reset one selected filter cartridge at a time and cannot reset multiple filter indicators simultaneously.
2. If there is no operation within 10 seconds, during each stage of the filter resetting process, the system will exit the setting stage.

Replacement Filter Part Number

Follow the system flush instructions on page 9 to flush the new filter cartridge.

Part No.	Description	Recommended Replacement Cycle
HEDPF1005_S9	PPC Filter Cartridge	6 Months
HEDPF2005_S9	RO Filter Cartridge	9 Months
HEDPF3006_S9	T33 Filter Cartridge	6 Months
HEDPF3007_S9	ALK Filter Cartridge	6 Months

System Maintenance

When you plan to not use the system for a period (More than a week)

Before shutting it off, please drain the filter cartridges and feed water tank. Place the system on a dry and secure surface at ambient room temperature, avoiding direct sunlight.

When you intend to use it again, to ensure the freshness of the drinking water, please clean the feed water tank first and then flush the system once. (The water supply may be different depending on your feed water source and quality. Thus, please adjust the frequency of flushing it accordingly.)

Feed Water Tank Rinsing Instructions

To maintain your system, it's recommended to clean the feed water tank and components every month, which helps to extend the service life of the filter cartridges. Check the strainer filter, water level float, and two check valves located on the bottom of the tank are clean.

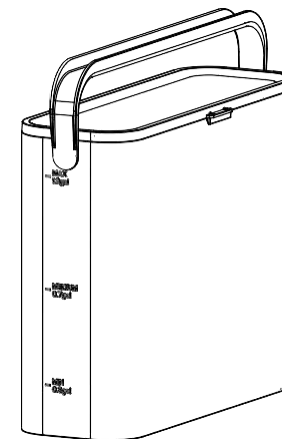

Feed water tank

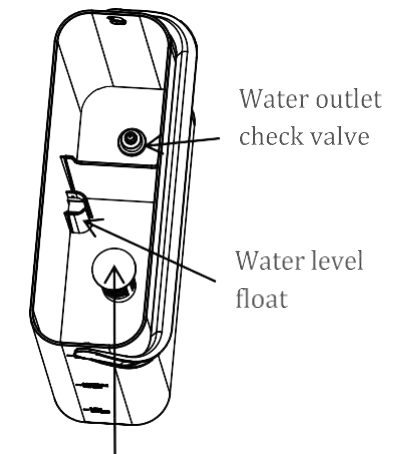

Strainer filter for water inlet

Tank Strainer Rinsing Instructions

Rinsing of stainless steel filter screen components.

1) When the system has been used for more than a month, in order to ensure the smooth flow of water and prolong the service life of the filter cartridge, it is necessary to take out the stainless steel filter screen components regularly and rinse the inside and outside with a small brush.

2) Please take it out according to the following steps.

Step 01

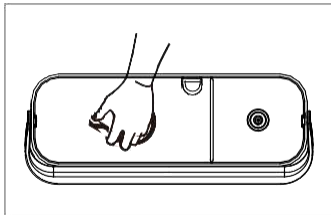

Lift out the water tank and place it on the horizontal surface. Open the feed water tank cover.

Pull out the stainless steel filter screen assembly and rinse the inner and outer mesh surface with a small brush.

Step 02

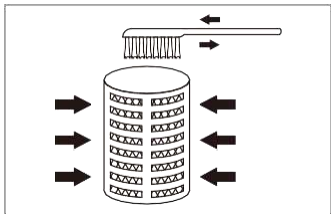

After rinsing with a small brush, install it back to the specified position of the feed water tank.

System Check Valves Maintenance and Rinsing Instructions

When the machine has been used for more than a month, it is recommended (but not compulsory) to regularly rinse the check valve components to ensure smooth water flow and prevent leaks. Please follow the steps below to rinse the check valves:

Step 01

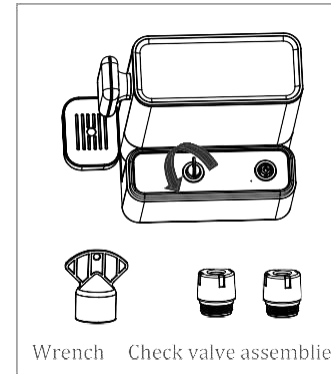

Grab the wrench from the kit and lift the water tank. On the water tank base, you will find two detachable check valve assemblies. Insert the wrench into the slot of the check valve assembly and turn it counterclockwise to remove the check valve assembly (one for water inlet and one for water outlet).

As shown in the left figure, there is a wrench and two removed check valve assemblies.

Step 02

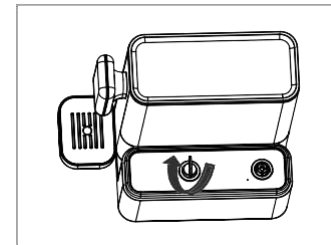

Thoroughly clean the surface of the check valve assembly and the area where it is installed. Then, use the wrench to gently turn the check valve clockwise back into its original position. (make sure not to apply excessive force)

Note: If the check valve assembly is damaged, it is recommended to replace it with a new one.

Other Parts Maintenance Instructions

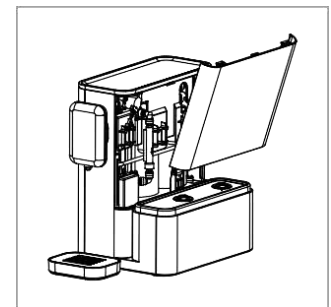

Remove the right panel as described on page 15, and you can replace other components as needed.

Note: If you need to replace the parts, please consult customer service first.

How to Remove Scale

Scale will develop over time and can clog the machine and disrupt product water flow rate. If you start to experience slow water flow rate or all the indicator lights keep flashing, it is time to maintain the water purifier.

1. Purpose

To clean the scale in the RO machine system (such as pipes, valves, pumps, RO membranes, etc.)

2. Recommended Frequency:

Low TDS (TDS<150ppm): every 6 months;

Fair TDS (150<TDS<250ppm): every 2 months;

Medium TDS (250<TDS<450ppm): every month;

High TDS (TDS>450ppm): every 2 weeks

Note: Total dissolved solids (TDS) is the total amount of solids dissolved in the water, including soluble hydrogen carbonate ions, chloride salts, sulphates, calcium, magnesium, sodium, potassium, volatile solids and non-volatile solids. Its concentration will affect the taste of drinking water. TDS in water can be measured using a digital meter.

3. Maintenance Steps

Step1:

Make one of the following DIY solutions or use a commercial descaling solution.

(1) Citric acid solution: Add 1.3 gallons of tap water to the feed water tank, then add 100 grams (about 10 tablespoons) of citric acid powder and stir well.



(2) White vinegar solution: Add 0.66 gallons of tap water to the feed water tank, then add 0.66 gallons of white vinegar, and stir well.

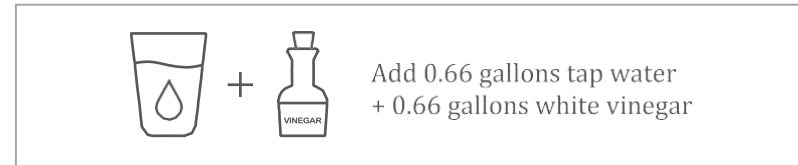

Step2:

Put the feed water tank with the prepared solution back on the machine and plug it in.

Step3:

Push and hold the Flushing Button for 3s, you will hear 1-beep, the Flushing Button will be on, and the system will initiate internal flushing for 5 minutes and stop. Repeat this internal flushing step two times.

Step4:

Unplug the power and let it stand for 0.5 to 1 hour.

Step5:

Remove the feed water tank, empty these solutions, and clean the feed water tank with tap water.

Step6:

Fill the feed water tank with tap water and put it back in the correct place, then plug in the power supply. Pressing the Dispense Button to dispense water to flushing the system, which removes the odor or taste of the descaling solution. If the sour taste remains, please repeat for a few more rounds until the water tastes good.

Note: If the scale is very serious or the problem is still not solved after maintenance, please repeat steps 1-6 one more time.

Troubleshooting Guide		
	Problem	Possible Solution
1	When pressing the control panel, the system does not turn on or respond	Plug the system into the electrical outlet and make sure the outlet switch is on, you will hear 2-beeps when connecting to the power.
		Plug the system into a different electrical outlet to check the outlet is working.
		If the system does not turn on after following the above instructions, please contact SimPure® customer service for assistance.
2	The system does not dispense water (change water light be on)	Feed water tank level too low, drain concentrate and refill the Tank with freshwater.
		Clean the float in the water tank to ensure that it can float freely up and down.
		The feed water tank is not installed correctly check if it's located onto the system base precisely.
3	The system does not dispense water (change water light goes out)	The stainless steel filter of the feed water tank inlet is clogged. Please follow the page 19 to clean it.
		The filter cartridges are clogged by impurities, Push and hold the Flushing Button for 3s, observe whether there is flushed water in the feed water tank drain out from the water outlet, if no or the water flow is low, please replace all filter cartridges.
		The filter cartridges are clogged by limescale, Please follow the page 21 to maintain it.
		If still not solve it after following the instructions above, please contact SimPure® customer service for assistance.

Troubleshooting Guide		
	Problem	Possible Solution
4	Water taste is poor or has a strange smell	If the system is new or has not been used for a long time, please flush the system(Page9-10).
		Push and hold the Flushing button for 3s to initiate internal flushing, repeat it 3 times. Then press the Dispense Button to empty the feed water tank.
5	The system makes excessive noise during operation Note: The system does make noise when processing water; this is normal.	The feed water tank water level is very low. Empty the feed water tank and refill with fresh potable (tap) water.
		There's an air blockage in the water production system. Unplug the unit from the electrical outlet for 3 minutes then reconnect. Flush the System 1-3 times before using (Page 9).
		Feed water quality is poor; filters have been blocked early (before replacement schedule). Replace all filters.
6	All the lights flashing twice	Plug it in. All indicator lights will be on and flashing twice, this is a self-check program. No action required.
7	All the lights keep flashing	If the system continues dispensing water for more than 30 minutes, the "Safety Protection" is activated, will beep 3x and all lights will flash. Reset the System by reconnecting the electrical power.(Page 12)

Warranty

SimPure® warrants to the customer that its Whole House Water Filter System will be free from defects in material and workmanship under normal use and service for a period of 1 year. We will replace or repair any part of the SimPure® Whole House Water Filter System that we find to be defective in operation due to faulty materials or workmanship within one year since the original purchase date. Used replaceable filter cartridges and membranes are excluded.

General Conditions

SimPure® obligation to the customer under these warranties shall be limited, at its option, to replace or repair items covered by these warranties. Prior to returning or repairing covered items, the customer must obtain a return goods authorization number from SimPure® and, at SimPure® option, return the item with freight prepaid by the customer.

Damage to any part of this system because of misuse, misapplication, negligence, alteration, accident, installation, or operation contrary to our instructions, incompatibility with accessories not installed by SimPure®, or damage caused by freezing, flood, fire, or Acts of God are not covered by this warranty. In all such cases, regular charges will apply. This limited warranty does not include service to diagnose a claimed malfunction in this unit. This warranty is void if the claimer is not the original purchaser of the unit or if the unit is not operated under normal municipal water or well water conditions. We assume no warranty liability in connection with this system other than that specified herein. This warranty is in lieu of all other warranties, expressed or implied, including warranties of fitness for a particular purpose. SimPure® liability hereunder shall not exceed the cost of the product. Under no circumstances will SimPure® be liable for any incidental or consequential damages or for any other loss, damage, or expense of any kind, including loss of use, arising in connection with the installation or use or inability to use the covered items. These warranties are governed by the laws of the state of Washington, USA, and may change at any time without notice.

Our Products & Services

Consumables

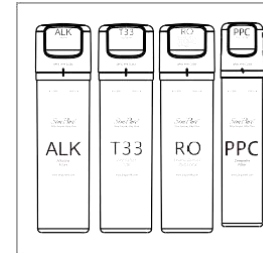

A full selection of consumable items to maintain your SimPure® countertop water purification system well into the future are available from SimPure® online or through your local Distributor.

www.amazon.com/simpure

Whole House Filtration System



SimPure® Whole House Pre-Filter (DC5P series and Big blue series) help to purify the water coming into your home.

Lasts Longer To Give You The Best Value In Filtration.

Under Sink RO Water Filter System



SimPure® T1-400 series RO water filtration system features unique UV sterilization technology, a filtration pore size of 0.0001µm, 400GPD, and 8-stage filtration, providing multiple choices for your family with pure water and alkaline mineral water.

Customer Service: service@simpurelife.com

Toll-Free: +1-866-528-4572

Website: www.simpurelife.com