

Installation Guide

Smart Door Locks Australia

SmartDL 5-in-1 Lever

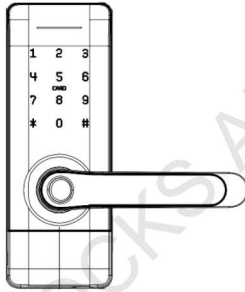

First, please refer to the **installation video** by scanning the QR code below.



Precautions for Installation

WARNING: FAILURE TO FOLLOW THESE INSTRUCTIONS COULD RESULT IN DAMAGE TO THE PRODUCT AND COULD LEAD TO FAILURE OF THE PRODUCT TO PROVIDE ACCESS

- For your safety, be careful when operating tools or heavy machinery during installation.
- For best results, avoid installing the product in a rainy, humid, or saline environment (e.g. coastal area), or a place exposed to direct sunlight for a long period of time.
- Long-term exposure to direct sunlight may cause a crack on the touch pad. Avoid exposure to direct sunlight.
- Excessive dew condensation may affect product performance.
- You must not repair this product without authorization.
- Install the product while the **door is open**. Even after completing the installation, **do not close the door** until you check if the product is operating properly.
- While installing the product, do not let it **fall to the ground**. If the product falls or is dropped during installation, you may be injured or the product may be damaged.
- Do not install the batteries until you complete the installation. When it is powered up, it will find the door direction automatically, installing the batteries prior to the lock being fully installed may affect the automatic door direction process.

Packing List

Item	Qty	Item	Qty
Exterior Assembly	1	Mortise Screws: 10*5 mm (For Aluminum Door)	4
Interior Assembly	1	Mortise Screws: 25*4mm (For Wooden Door)	4
Latch	1	60mm/80mm Square shaft	2
Key Fobs	3	M5*25mm Screw for Door Thickness 35-39mm	2
Mechanical Keys	2	M5*30mm Screw for Door Thickness 40-50mm	2
Waterproof Rubber Plates	2	M5*40mm Screw for Door Thickness 50-65mm	2
Screw Stubs: M5*35 mm	2	M3*6mm Panel screws	3
Screw Stubs: M5*30mm	2	Chuck	1
Strike & Strike Box	1+1	U-Clip	1
Sliding Screws: 16*5mm	2	User Manual	1

Installation Guide

1. Preparing the door

1.1. If you are installing the SmartDL 5-in-1 Lever smart door lock on an existing door, please remove existing door hardware and latch or bolts before installing the new lock.

You can remove most existing door locks with a screwdriver.

If you are having problems removing your existing door lock or unsure if what you are doing can damage the existing door, please contact a locksmith or the current door hardware manufacturer for assistance.

1.2. After removing the existing lock, make sure your door is properly prepared. If you need to drill holes in your door, please use supplied templates to assist.

2. Installing the latch

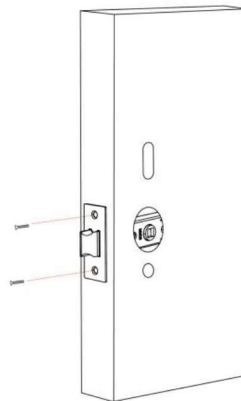
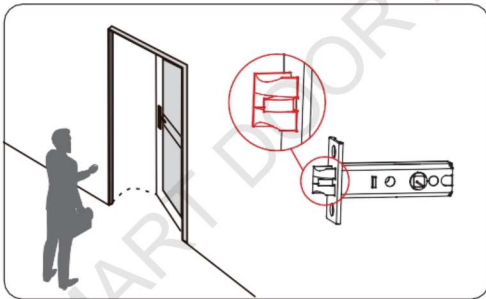

2.1 Based on your door closing direction, you have to orient the slanted side of the latch to face towards the closing direction of the door.

2.2 Install the lockset with the slanted side of the latch facing towards the closing direction.

3. Changing handle orientation for right or left swing doors

How to check if your door is a Right Swing or Left Swing door?

While facing the door, if the door hinges are on the right side of the door, you have a Right Swing Door. If the hinges are on the left side of the door, you have a Left Swing Door.

You may skip this step if your door matches the factory default handle orientation. To change your door handle orientation, please continue reading.

Changing the Exterior Handle Orientation

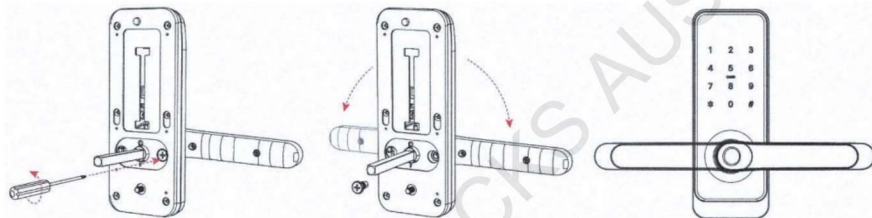

3.1 Remove the screw using a screwdriver as shown.

3.2 Rotate the handle 180 degrees to the other side of the lock.

3.3 Re-install the screw to secure the new handle orientation.

Changing the Interior Handle Orientation

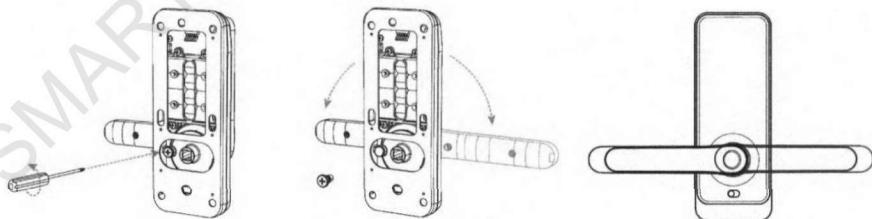

3.4 Remove the screw using a screwdriver as shown.

3.5 Rotate the handle 180 degrees to the other side of the lock.

3.6 Re-install the screw to secure the new handle orientation.

4. Installing the exterior handle

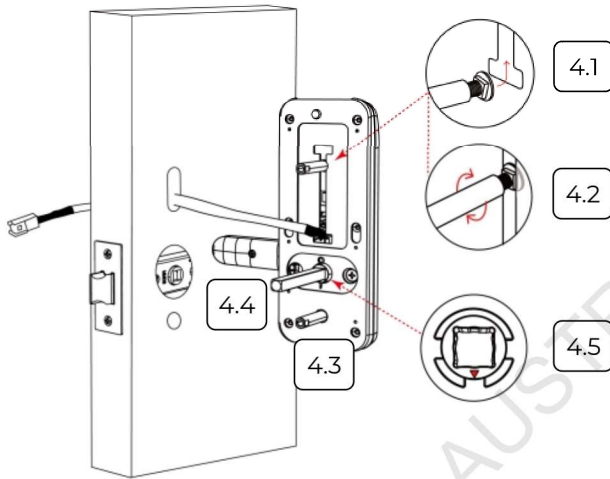

4.1 Insert the sliding screw into the sliding screw cylinder.

4.2 Fix the sliding screw assembly to the handle and align to the screw hole position on the door.

4.3 Insert the bottom screw cylinder.

4.4 Insert the square spindle and secure it with the u-clip provided.

4.5 Turn the spindle by hand and make sure the arrow is pointing down.

Important: If the arrow is not pointing down, the lock mechanism will fail to unlock

4.6 Install the rubber gasket.

4.7 Push the connection cable through the door.

4.8 Install the exterior lock as shown by aligning the lock straight and passing the attached rods through the lockset.

4.9 Secure the external handle to the door using a small-double sided tape or hold it until the internal handle is fixed.

5. Installing the Interior handle

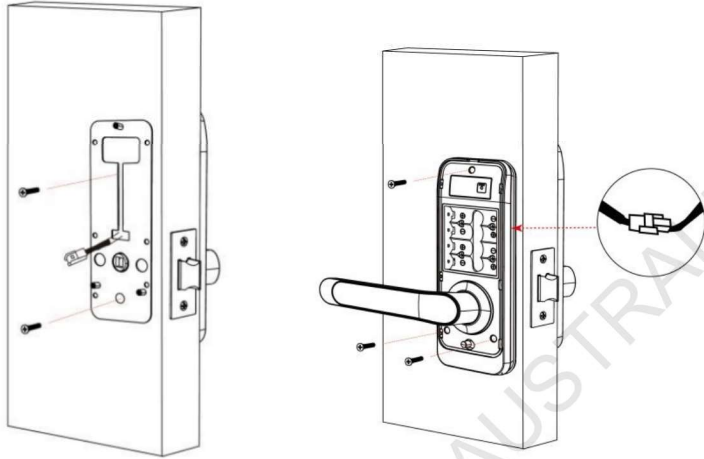

5.1 Install the mounting plate against the interior side of your door.

5.2 Install the rubber gasket.

5.3 Plug the cable that is coming through the door into the interior lock. Make sure you match the direction of the plug correctly.

5.4 Remove the battery cover and keep it aside.

5.5 Align the square rod to the Interior lock and attach the Interior lock to the door frame. While you are doing so, gently push the excess cable through the hole into the door cavity. Place the remaining cable against the interior side of the Interior lock so the Interior lock sits securely onto the door surface.

5.6 Once the Interior lock is flushed against the door frame, secure the lock to the plate by screwing clockwise by using supplied screws.

6. Installing batteries

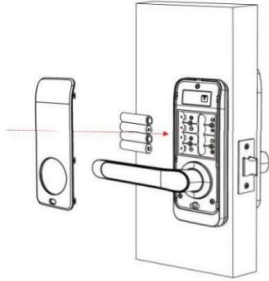

6.1 Insert the batteries into the lock by matching the positive (+) and negative (-) orientation markings on the batteries to the battery chamber.

6.2 Secure the battery cover.

7. Installing the door strike

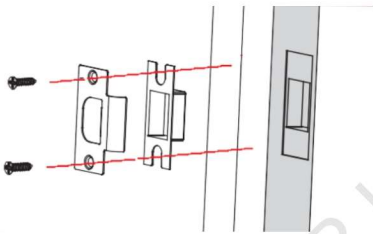

7.1 Make sure the slanted side of the latch is closing against the slanted part of the strike plate before fixing it on to door frame.

7.2 Fix the door strike to the door frame.

8. Finishing installation

8.1 You're all done! You have completed the physical lock installation and now you're ready to get the lock set up.

Power and Test

1. Activate the lock

1. Make sure fresh batteries are installed.
2. Touch or slide your finger over the keypad.
3. This should turn on the keypad and should provide voice feedback.

2. Test Lock and Unlock

Important:

- Make sure you perform these operations while the door is open.
- Do not close the door until you have completed the programming and made sure the product is operating properly.

From outside

1. Turn down the outside handle, the Latch should not unlock.
2. Enter the default passcode '123456#' and turn down the outside handle, the Latch should unlock.

From inside

3. Turn down the inside handle, the Latch should unlock.

If all the steps above are successful, you can begin the programming of SmartDL 5-in-1 Lever. Otherwise, please re-install SmartDL 5-in-1 Lever carefully as shown in the 'Installation Guide' section.

User Guide

1. Product Overview

1.1. Exterior

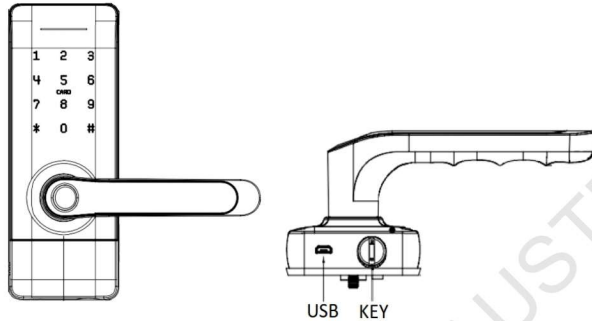

Anti-peep Keypad

Used to enter the code and unlock from the outside.

Fingerprint Reader

Used to verify your finger and unlock from the outside.

Key Fob/IC Card Reader

Used to verify your key fob and unlock from the outside.

Micro USB (5V)

Used to connect a power bank to activate the lock when it runs out of battery.

Backup Key Hole

Used to insert the key to unlock.

Outside Handle

Used to lock or unlock SmartDL 5-in-1 Lever

0-9 Number Button

Used to input key code and unlock from outside.

1.2. Interior

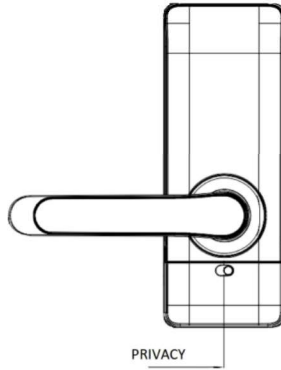

Battery Cover

Used to cover the batteries and reset button.

Reset Button (inside the battery cover)

Used to reset SmartDL 5-in-1 Lever to factory default settings.

Inside Handle

Used to lock or unlock SmartDL 5-in-1 Lever from inside.

Privacy Lockout switch

Used to turn on/off privacy lockout when necessary.

2. Basic operation

2.1. Cleaning the Keypad and Finger Reader

Use a microfiber cloth and wipe across the Anti-peep Keypad, Fingerprint Reader and Key Fob Reader.

2.2. Lock Activation

Place a finger on the Fingerprint Reader, touch the Anti-peep keypad with the back of your hand or fingers, or, present the Fob on the Key Fob Reader.

2.3. Unlock from outside

Unlock by Code

1. Place a finger on the Anti-peep Keypad to activate SmartDL 5-in-1 Lever
2. Input the 4-8 digit User Code from a registered user and press #
3. Rotate the handle down to unlock SmartDL 5-in-1 Lever.

Unlock by Fingerprint

1. Press the finger from a registered user on the middle of the Fingerprint Reader to unlock it
2. Rotate the handle down to unlock SmartDL 5-in-1 Lever

Unlock by Key Fob

1. Present the Key Fob from a registered user on the Key Fob Reader.
2. Rotate the handle down to unlock SmartDL 5-in-1 Lever.

Unlock by Smartphone

1. Press the Unlock Button in the TTLock App.
2. Rotate the handle down to unlock SmartDL 5-in-1 Lever.

Backup Key

1. Locate the keyhole at the bottom of SmartDL 5-in-1 Lever's Exterior Assembly.
2. Insert the backup key with a vertical position and rotate it to a horizontal position to open it.
3. Rotate the handle down to unlock SmartDL 5-in-1 Lever.

2.4. Unlock from inside

1. Rotate the handle down to unlock SmartDL 5-in-1 Lever.

2.5. Lock from outside

Lock Latch

When Auto-Lock is on:

SmartDL 5-in-1 Lever will lock the Latch automatically 5 seconds after the last unlock (time duration can be configured using the TTLock app).

When Auto-Lock is off:

1. Place a finger on the Anti-peep Keypad to activate SmartDL 5-in-1 Lever.
 2. Press and hold the # key for 3 seconds.
- Or Tap the 'Padlock' icon on the TTLock App.

Lock Bolt

Lift the Outside Handle up to lock the Bolt.

2.6. Lock from inside

Lock Latch

When Auto-Lock is on:

SmartDL 5-in-1 Lever will lock the Latch automatically 5 seconds after the last unlock (time duration can be configured using the TTLock app).

When Auto-Lock is off:

Tap the 'Padlock' icon on the TTLock App.

Lock Bolt

Lift the Inside Handle up to lock the Bolt.

2.7. Factory Reset

Important: All data will be erased if you reset SmartDL 5-in-1 Lever to factory default settings.

1. Open the battery cover.
2. Use a paper clip and press the "Reset" button for 5 seconds.
3. Press "000#" to complete the reset process.

2.8. 5V Emergency Power

Note: 5V Emergency Power is only for temporary power or not being able to charge the lock.

1. Locate the USB port at the bottom of SmartDL 5-in-1 Lever's Exterior Assembly.
2. Use a regular 5V power bank to power.

2.9. Anti-peep Keypad

The lock supports 4-8 digit key codes. You can choose to enter any 16 digit code, as long as a correct code is included within the sequence of numbers you have entered.

Example User Code: **1234**

Example Valid Keypad Input: 045**1234**794

2.10. Finger Placement

- Your finger should cover the Reader completely with some pressure, touching the surrounding metal ring.
- Make sure that your finger and the Fingerprint Reader are clean and dry. For the Fingerprint Reader, use a clean microfiber cloth to wipe off any dirt or debris.

- While scanning your finger, you shouldn't tap too quickly or move your finger around.
- If you have trouble enrolling one finger, try another.

2.11. Use the Key Fob

When using the Key Fob access, please place the Key Fob at the centre to cover the reader.

Approach the sensor with medium speed (instead of sudden motion). If it's not working, move the Key Fob away and re-try.

2.12. Lock Status

Normal Mode

This is the default mode. User must pass the fingerprint, code, fob or App access verification to unlock SmartDL 5-in-1 Lever from outside.

Passage Mode

SmartDL 5-in-1 Lever will stay unlocked for convenient free passage.

Privacy Lockout Mode

When the privacy lockout switch is in the 'lockout' state (i.e. red), it can only be unlocked from outside, by the master admin user or using the backup mechanical key. Indoor Handle always works.

Programming Guide

Important:

- Enable Bluetooth on your smart phone before continuing.
- All the operations related to configuring the new smart lock should be performed within one meter radius to the lock.

1. Download the app

Use the QR code below or go to your application store and search for the 'TTLock' application.



This section shows you the basic configurations of the smart lock using the TTLock application to get you started using the smart door lock.

For a complete guide of the TTLock application functions, scan the QR code below.



2. Login to TTLock Account

If this is your first time using the TTLock app, you have to register a new user account. Once an account has been created, you can use the same account to manage all of your locks.

If you already have an account you can skip the registration and login to the application with your account credentials.

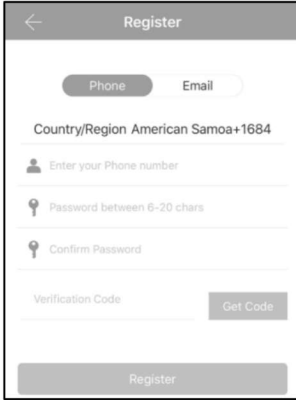

The screenshot shows the 'Register' screen of the TTLock app. At the top, there is a back arrow and the title 'Register'. Below the title, there are two radio buttons for 'Phone' (selected) and 'Email'. A dropdown menu shows 'Country/Region American Samoa+1684'. There are three input fields: 'Enter your Phone number', 'Password between 6-20 chars', and 'Confirm Password'. Below these is a 'Verification Code' field and a 'Get Code' button. At the bottom, there is a large 'Register' button.

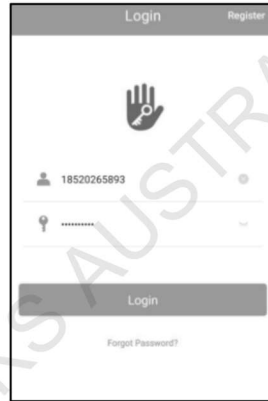

The screenshot shows the 'Login' screen of the TTLock app. At the top, there is a back arrow and the title 'Login'. Below the title, there is a hand icon with a keyhole. There are two input fields: one for the phone number '18520265893' and one for the password. Below these is a 'Login' button and a 'Forgot Password?' link.

Registering a new account

- 1.1 Open the TTLock application.
- 1.2 Follow the prompts to register a new account.

Login to the account

- 1.3 Login to your account with your username and password.

Login Successful

Once you are logged into the application you will be taken to the Home page of the TTLock application.

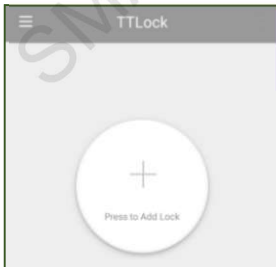

3. Adding the lock to the TTLock app

Important:

- The default password is 123456#.
- Once you complete this step, you will become the Bluetooth administrator of the lock. And, there can be only one **Bluetooth administrator** for a given lock.
- You can add more users with administrator privileges. But, the Bluetooth administrator has the highest permission level.
- To remove a **Bluetooth Administrator**, go to the 'Factory Reset' and follow the steps to reset the lock to the factory default.

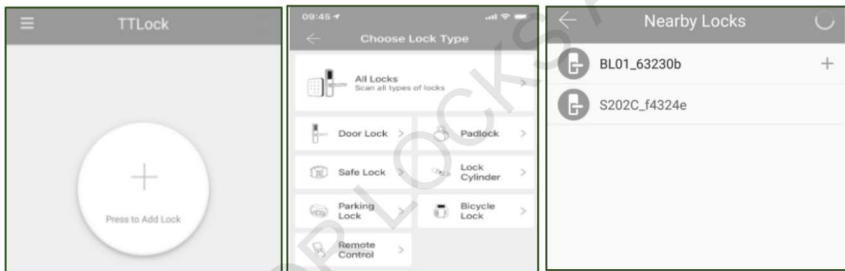

1.4 Tap the add button.

1.5 Tap the 'All Locks' button.

Important: Make sure the smart lock active (or keypad is illuminated). If not, touch or slide your finger over the keypad until the keypad is illuminated.

1.6 Now the application will scan for nearby locks and once a lock is found, tap the '+' button next to the correct lock.

1.7 Enter a lock name. E.g. Front door, Room 1.

1.8 If successful, you will be taken to the Home page of the new lock. Now the lock is added to your account and ready to be configured.

4. Configuring the lock access using TTLock application

Unlock using the TTLock application

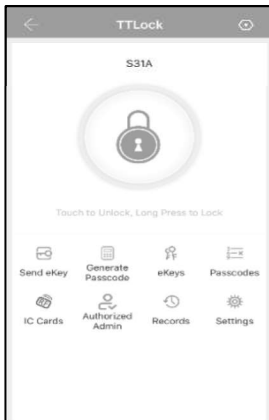

1.9 Make sure you are on the Home page of the newly added lock.

1.10 tap the 'Padlock' icon to unlock the smart lock.

1.11 If successful, you will hear the sound of the lock handle engaging and you should be able to unlock the lock by rotating the exterior handle.

Setting a passcode

There are multiple types of passcodes such as permanent, time-limited, one-time, etc. You can choose to create any type based on your access requirements for each user.

You can also choose to generate a random passcode from the Application or a custom passcode based on your needs.

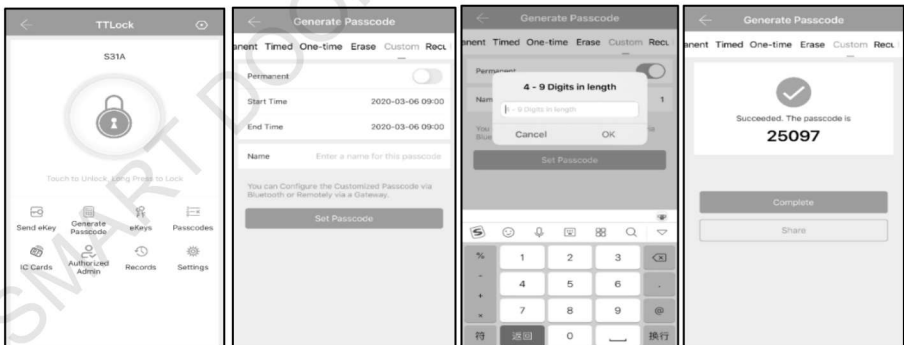

1. From the Home page options, tap 'Generate Passcode'.
2. Choose the type of passcode you want to create by navigating the tabs.
3. Generate the new passcode.

Send e-key

You can send e-keys to other users to grant application access to the lock.

Important: The receiver must have the TTLock application installed and registered with TTLock prior to receiving the e-key.

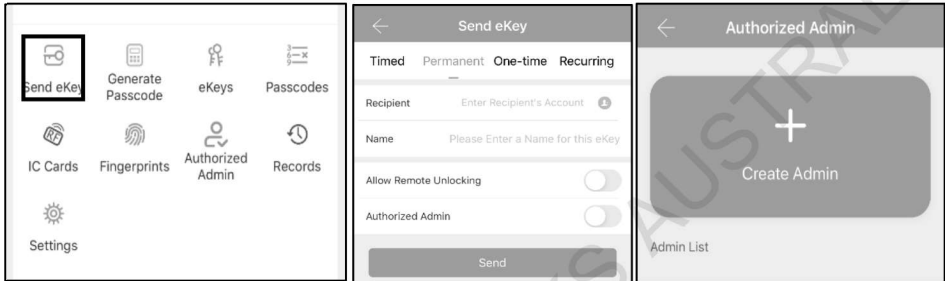

1. Tap 'Send eKey' on the lock Home screen.
2. Select the e-key type by navigating the tabs (i.e. timed, permanent, one-time, recurring).
3. Enter the recipient's TTlock account username and name.
4. You can choose to 'Allow Remote Unlocking' capability, if necessary.
5. Select 'Authorized Admin' if you want to make this user an administrator.
6. Tap 'Send'.

Register IC Card/Key Fob

Important: This operation must be performed near the lock.

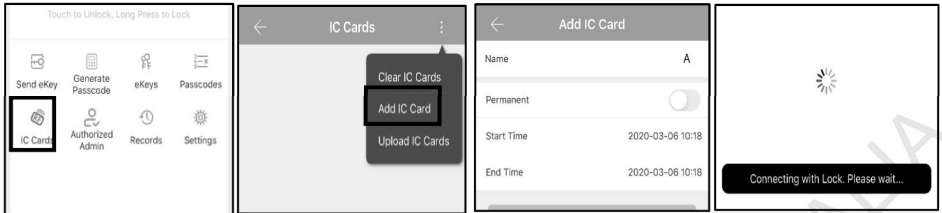

1. Tap 'IC Cards' on the lock Home screen.
2. Select 'Add IC Card' from the context menu.
3. Enter IC card details.
4. Tap the IC Card to the exterior lock panel IC card reader area.

Register fingerprint

Important: This operation must be performed near the lock.

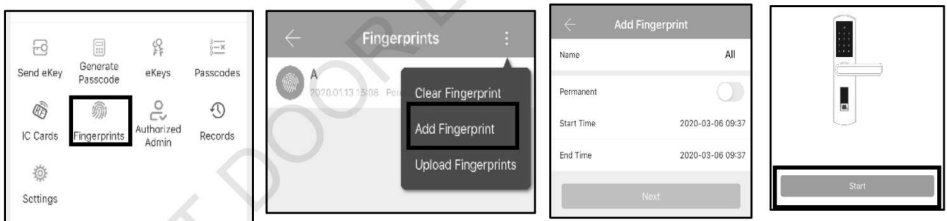

1. Tap 'Fingerprints' on the lock Home screen.
2. Select 'Add fingerprint' from the context menu.
3. Enter fingerprint details.
4. Start the fingerprint scan process and follow the on-screen instructions.

Check Logs

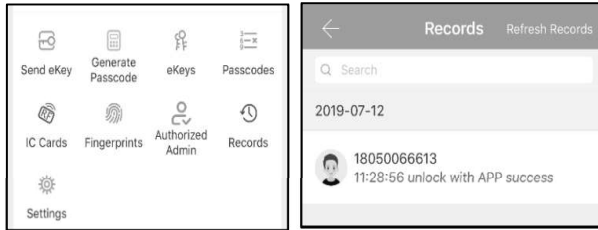

1. Tap 'Records' from the lock Home screen.

2. Configuring the Wi-Fi Gateway (optional)

Important:

- You should install the Wi-Fi Gateway only after you have successfully finished installation and set up of your Smart Lock using Bluetooth.
- When configuring, your phone and the Wi-Fi gateway must be connected to the the same 2.4GHz network.

Understanding indicator light status



When the gateway is powered on:

- Light flashes alternately in red and blue: Stand-by mode, ready for pairing
- Blue light: Working mode
- Red light: Network failure

Pairing the Wi-Fi Gateway with the TTLock App

1 Activate the APP



2 Press "☰"



3 Select [Gateway]



4 Select [G2]

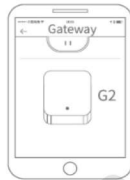

5 Plug in the gateway and power it on, while the light flashes alternately in red and blue

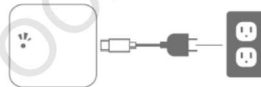

6 Press "+" sign



7 Add Gateway



8 Select the network and fill in the password

