

SMT Interior Spotlight

Model: SMT23-BLK Installation Instructions

All installations must be carried out by a qualified electrician following local regulations. Make sure that the power is switched off before installation. Please read and follow the 'Installation instructions' and 'Safety instructions' sections carefully before commencing installation. Installation of this model can change from time to time please read instructions every time before installation. For detailed specification, please go to our website eurotechlighting.co.nz

Code:	Colour:	Dimensions (mm):	Dimmable:	Driver:	IP Rating:	Kelvins:	Lumens:	Material:	Watts:
SMT23-BLK	Black	50Ø x 175	Yes	Integral	IP20	4000K	870lm	Aluminium	13W

Product Information

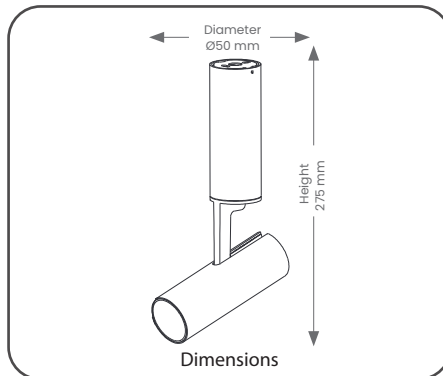

Installation Instructions

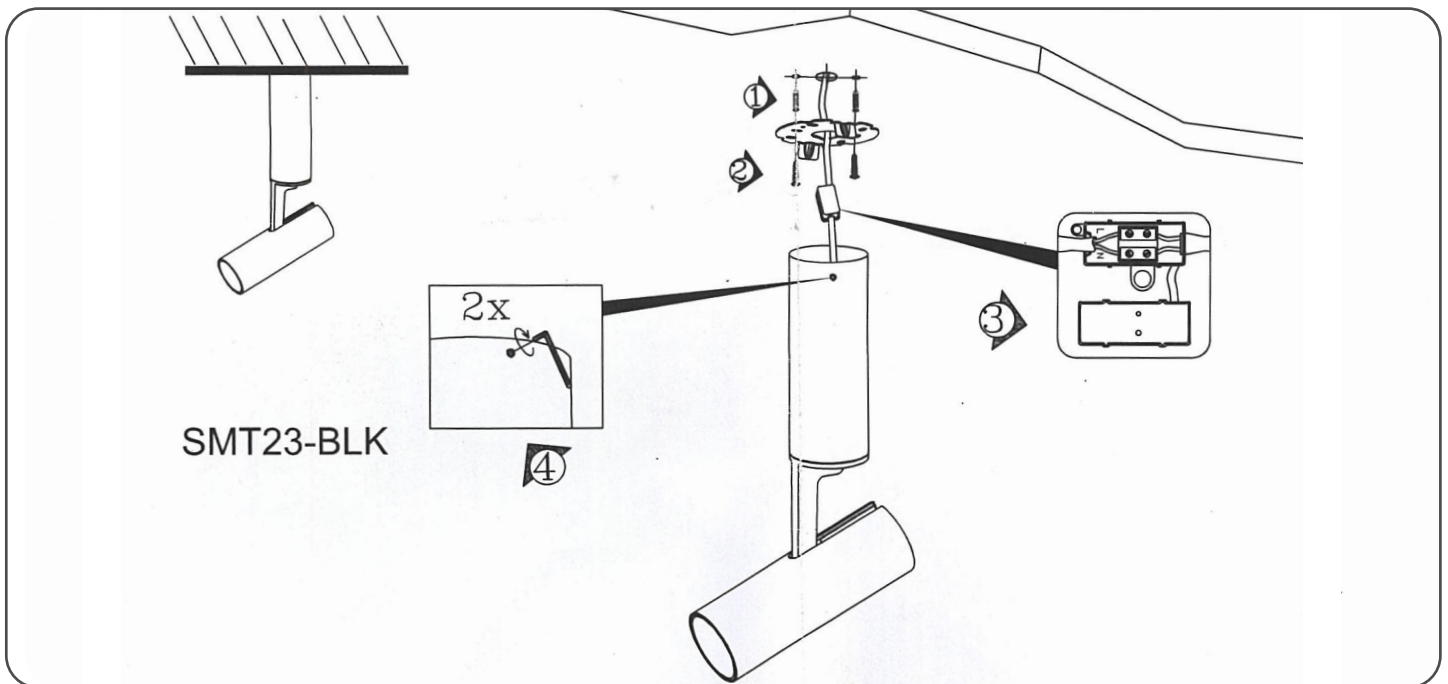

Safety Instructions

Read these instructions carefully before commencing installation.

1. The light source contained in this luminaire shall only be replaced by the manufacturer or this service agent or a similar qualified person.
2. This LED luminaire must be installed by a licensed electrician ONLY following all local regulations.
3. Ensure that the cables will not be squeezed or damaged by sharp edges.
4. Clean the light with a soft cloth and a standard PH-neutral detergent.
5. Misuse of/or changes to the appliance shall void all warranties.



For detailed specification, please go to our website eurotechlighting.co.nz