

LuminOX LOX-2 25% Oxygen Sensor

The LuminOX LOX-2 Oxygen Sensor measures oxygen levels up to 25% at 0.01% resolution.

The sensor uses the principle of fluorescence quenching by oxygen using UV light. Unlike traditional electrochemical oxygen sensors, by using UV light the sensor has a lifetime measured in years instead of months. This makes it perfect for portable, medical, industrial or many other applications.

The UV Flux sensor is both oxygen pressure and temperature compensated, enabling accurate operation over a wide environmental range without the need for additional system components.



ELECTRICAL AND ENVIRONMENTAL SPECIFICATION

Supply Voltage (Vs)	4.5 to 5.5 Vdc
Supply Current (Is)	<7.5mA (streaming 1 sample per second), <17mA Peak
Output Type	3.3V TTL level RS232
Operating Temperature	-30°C to +60 °C
Storage Temperature	-30 C to +60 C
Humidity	0-99% Rh (non-condensing)
Barometric Pressure Range	500 to 1200mbar (0,% version)

PERFORMANCE SPECIFICATION*

Oxygen Measuring Range	0-25% (O ₂ % Version)
Response Rate	T90 < 30 sec. (typical)
Sampling Rate	1 Sample / sec.
Accuracy	< 2% FS / 0.1 mbar
Resolution	0.01% 0.1 mbar
Lifetime	> 5 Years
Pressure Measurement	Accuracy +/- 5 mbar (only available on 0% version)

* At ambient conditions under STP. Following extreme temperature fluctuations, re-calibration may be required.

BENEFITS

- Low power
- Also measures O₂% & barometric pressure (if selected)
- Suitable for battery power use
- Long life
- High accuracy
- Small & compact
- Low cost
- Maintenance free
- Contains no hazardous materials
- Connects directly to microcontroller without any additional circuitry.
- Factory Calibrated

APPLICATIONS

- Oxygen Detection
- Portable Equipment
- Breathing Apparatus
- Inerting
- Medical
- Lab Equipment
- Agriculture
- Incubation
- Fire Prevention
- Flue Gas in Condensing Boilers

COMPETITIVE ADVANTAGE

The UV Flux sensor was designed in order to overcome many issues associated with electrochemical technology, the biggest issue being life-time.

This table shows how the UV Flux sensor can give your product an overall competitive advantage compared to various technologies

	LuminOx	Zirconia	Electrochemical	Paramagnetic
Low Drift	✓	✗	✗	✓
Long Life	✓	✓	✗	✓
ROHS Compliant	✓	✓	✗	✓
Small in Size	✓	✗	✓	✗
Low in cost	✓	✗	✓	✗
Low Power	✓	✗	✓	✗

Cross-Sensitivity

The table below shows a list of gasses that have been tested for cross sensitivity with the LuminOx range.

The list below is not exhaustive. Compatibility with gasses not on this list need to be tested by the customer. The fluorescence technology used in LuminOx is inherently extremely selective to O2 so cross-sensitivity is generally unlikely.

Gas Measured	Cross Sensitivity
200 ppm NO in N2	None
100 ppm Acetaldehyde	None
100 ppm SO2 in N2	None
100 ppm H2S in N2	None
100 ppm HCl in N2	None
5 ppm Ethylene	None
1% methane in N2	None
0.5% CO	None
100% CO2	None
100 ppm NO2 in air	No result observed due to instability of NO2 sample gas

PRODUCT DIMENSIONS (All dimensions in mm)

OUTLINE DRAWINGS

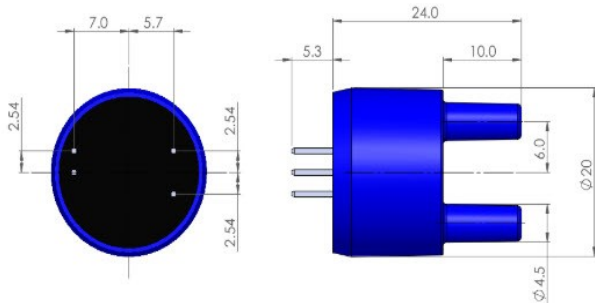

ELECTRICAL INTERFACE

