



## 4 Gases Density Transmitter via USB

# UA58-KFG-U

- Real-time Four Channel Gas Transmitter
- Compact Size Sensor for Indoor Air Quality
- CO, O2, H2S, CO2 density Support
- NDIR for CO2 and ElectroChemical for Others
- Operating On Windows / Linux / MacOS
- AT Command Support



The UA58-KFG-U device has an electrochemical gas(Carbon monoxide, Oxygen, Hydrogen sulfide) sensor and NDIR gas(Carbon dioxide) inside. It transmits measured density information of the four gases(CO, O2, H2S, CO2) in real-time via the USB connector.

The UA Series is automatically recognized as a serial port on the operating system and accessed using the AT command. Multiple USB connections of the UA device could compose the multi-channel sensor. The sensor data is not stored in the UA, but recorded in PC and Android device. 128CH real time monitoring software on pc, nest is downloadable on our website([www.radionode365.com](http://www.radionode365.com)). Android real time recording application nest mobile is also available from google play store. The optional RN17X model helps the UA series for you to setup remote web monitoring system.

### Hardware

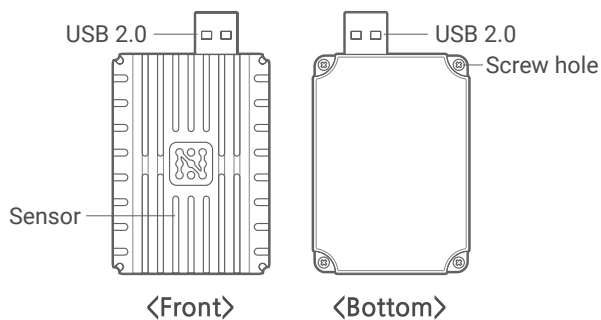

### ⚠ CAUTION!

- Volatile organic compounds (VOCs) should be avoided in applications where electrochemical sensors are used because they either dissolve in the electrolyte or adsorb onto the sensor's housing.
- Long term exposures and high concentrations may affect the performance characteristics
- Sudden changes in temperature/humidity cause short-term transient signals
- Avoid contact with conductors.
- Static electricity can cause distorted values.

### Dimensions

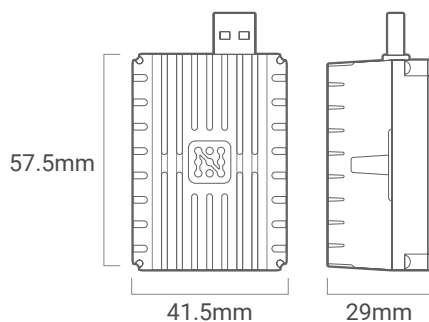

### Contact Information

- [www.radionode365.com](http://www.radionode365.com)
- [master@dekist.com](mailto:master@dekist.com)



## 4 Gases Density Transmitter via USB

### UA58-KFG-U Specifications

Sensor Channel Info.	<ul style="list-style-type: none"> <li>• CH1: CO (Carbon monoxide)</li> <li>• CH2: O2 (Oxygen)</li> <li>• CH3: H2S(Hydrogen sulfide)</li> <li>• CH4: CO2(Carbon dioxide)</li> </ul>
Gas Sensor Type	Electrochemical Cell & NDIR Optical sensor
Body Material	PC(Polycarbonate)
Measurement Range	<ul style="list-style-type: none"> <li>• CO: 0~1000ppm</li> <li>• O2: 0~25%</li> <li>• H2S: 0~100ppm</li> <li>• CO2: 400~10000ppm</li> </ul>
Measurement Unit (Selection using SW)	<ul style="list-style-type: none"> <li>• CO: ppm</li> <li>• O2: %</li> <li>• H2S: ppm</li> <li>• CO2: ppm</li> </ul>
Measurement Cycle	1.6 sec
Sensor Resolution	<ul style="list-style-type: none"> <li>• CO: 0.5ppm</li> <li>• O2: 0.1%</li> <li>• H2S: 0.5ppm</li> <li>• CO2: 1ppm</li> <li>• Temperature: 0.01°C</li> <li>• Humidity: 0.01%</li> </ul>
Sensor Accuracy (Repeatability)	<ul style="list-style-type: none"> <li>• CO: &lt;3% of measured value</li> <li>• O2: &lt;2% of measured value</li> <li>• H2S: &lt; 2% of measured value</li> <li>• CO2: ±50ppm+5% of measured value</li> <li>• Temperature: ±0.2°C</li> <li>• Humidity: ±2% RH</li> </ul>
Compensation Logic	Temperature
Baseline Drift	CO: -10~10ppm
Long-term Drift	<ul style="list-style-type: none"> <li>• CO: &lt; 10% signal loss/year</li> <li>• O2: &lt; 5% signal loss/year</li> <li>• H2S: &lt; 2% signal loss/month</li> <li>• CO2: NONE</li> </ul>
Gas Response Time	<ul style="list-style-type: none"> <li>• CO: T90 &lt; 50 secs</li> <li>• O2: T90 &lt; 10 secs</li> <li>• H2S: T90 &lt; 60 secs</li> <li>• CO2: T90 &lt; 30 secs</li> </ul>
Warming up Time	< 3mins after power-on
Operating Condition	<ul style="list-style-type: none"> <li>• Temperature: -10 ~ 50°C</li> <li>• Humidity: 15 ~ 90% R.H(non condensing)</li> </ul>
Lifetime <sup>1)</sup>	less than 24 month @ discontinuous measurement
Cross-Sensitivity	<ul style="list-style-type: none"> <li>• CO: H2, NO, C2H4</li> <li>• H2S: H2, CO</li> </ul>
Power Consumption	5V (Max 635mW)
Calibration Certificate	Individual Certificate. <ul style="list-style-type: none"> <li>• CO: Calibration with 50ppm CO calibration gas mixtures</li> <li>• O2: Calibration with 10% O2 calibration gas mixtures</li> <li>• H2S: Calibration with 50ppm H2S calibration gas mixtures</li> <li>• CO2: Zero-calibrate the CO2 sensor in clean air.</li> </ul>
Calibration Method	<ul style="list-style-type: none"> <li>• CO, O2, H2S: Two point calibration</li> <li>• CO2: Zero calibration</li> </ul>
USB Port	USB 2.0 Type A Plug
Output Signal	USB digital, CDC Device (AT Command)
LED	Device Status Indicator <ul style="list-style-type: none"> <li>• BLINK RED &amp; GREEN: Warming-up</li> <li>• RED KEEP ON: USB Connection Failed</li> <li>• BLINK GREEN: Measuring</li> </ul>
Software Support	<ul style="list-style-type: none"> <li>• Calibration Software</li> </ul> Calibrator that compensates measuring error. Download: <a href="http://www.radionode365.com">www.radionode365.com</a>

1) Gas sensors have a longer life when measured discontinuously than when measured continuously.

### Application

- Industrial safety Monitoring
- Air Ventilation System

### Product Components

Model	Component
UA58-KFG-U	<ul style="list-style-type: none"> <li>• UA58-KFG-U (1EA)</li> <li>• Calibration Cab (1EA)</li> <li>• USB Extension Cable 1.5m (1EA)</li> <li>• Calibration Certificate (1EA)</li> </ul>

### Optional Accessories

Type	Model Number	Spec.
Sensor data transmitter via Ethernet	RN171 WC	<ul style="list-style-type: none"> <li>• Supports cloud monitoring</li> <li>• Supports MODBUS TCP/ HTTP data transmission</li> <li>• Power: PoE 48V, IEEE802.3af/at, DC6V, 1.9W</li> </ul>
Sensor data transmitter via WiFi	RN172 WC	<ul style="list-style-type: none"> <li>• Supports cloud monitoring</li> <li>• Supports MODBUS TCP/ HTTP data transmission</li> <li>• Power: DC6V, 2.4W</li> </ul>