

iVAC Pro

WIRELESS SYSTEM

DEC HANDBOOK



Product variations exist.
For illustration only.

Read this handbook before installation & use - retain for future reference

This handbook is to be made available to all persons who are required to use, install, configure or service the equipment described herein, or any other associated operation.

Installation, operation and maintenance of the equipment should be carried out by competent personnel. A competent person is someone who is technically qualified and familiar with all safety information and established safety practices; with the installation process, operation and maintenance of this equipment; and with all the hazards involved.

FAILURE OR IMPROPER SELECTION OR IMPROPER USE OF THE PRODUCTS DESCRIBED HEREIN OR RELATED ITEMS CAN CAUSE DEATH, PERSONAL INJURY AND PROPERTY DAMAGE.

This document and other information from iVAC, its subsidiaries and authorised distributors provide product or system options for further investigation by installers and users having technical expertise.

The user, through its own analysis and testing, is solely responsible for making the final selection of the system and components and assuring that all performance, endurance, maintenance, safety and warning requirements of the application are met. The user must analyse all aspects of the application, follow applicable industry standards, and follow the information concerning the product in the current product catalog and in any other materials provided from iVAC or its subsidiaries or authorised distributors.

To the extent that iVAC or its subsidiaries or authorised distributors provide component or system options based upon data or specifications provided by the user, the user is responsible for determining that such data and specifications are suitable and sufficient for all applications and reasonably foreseeable uses of the components or systems.

Contents

1.0 iVAC Pro Switch DEC (Dust Extractor Controller) – Overview (page 4)

2.0 User Operation (page 5)

- 2.1 Warnings - User Operation
- 2.2 Pro Switch function
- 2.3 Mode Switch (AUTO, OFF or ON)
- 2.4 AUTO Mode - Operation process
- 2.5 LED Indicator
- 2.6 Functional features explained
- 2.7 Physical Features

3.0 Configuration – Programmable features (page 10)

- 3.1 System ID (Address)
- 3.2 Wait until Dust Extractor Stops
- 3.3 Turn OFF Time Delay and Minimum Run Time

4.0 Installation (page 13)

- 4.1 Warnings - Installation
- 4.2 Mounting and Location
- 4.3 Electrical Connections – General Information
- 4.4 Relay Wiring – Illustration & Explanation
- 4.5 Connection options
- 4.6 Direct Switching (single or double pole)
- 4.7 Digital Input Control (e.g. VFD Motor Drive)

5.0 Warranty (page 19)

6.0 Service and Repairs (page 19)

7.0 Specifications (page 19)

8.0 Contact (page 20)

1.0 iVAC Pro Switch DEC (Dust Extractor Controller) – Overview

This Handbook covers the Operation, Configuration and Installation of the iVAC Pro Switch DEC (Dust Extractor Controller).

The iVAC Pro Switch DEC is the component within the iVAC Pro System that is used to control your Dust Extractor.

Installation and operation is simple and easy as the iVAC Pro Switch DEC communicates with all other Pro System components wirelessly – no cable links are required.

To operate your Pro Switch you need one or more iVAC wireless transmitters - Pro Remotes or Pro Tool Plus's.



Pro Switch



Pro Remote Transmitter (manual)



Pro Tool Plus Transmitter (automatic)

Wireless remote control of the Pro Switch can be Manual, Automatic or Both:

Manual, The Pro Remote is portable (hand held) and allows you to switch your Extractor ON or OFF from anywhere in your workshop.

Automatic, The Pro Tool Plus is clamped onto your power tool supply cable, it detects when the tool is running and automatically switches your Extractor ON and OFF as required.

Manual & Automatic, Pro Remotes and Pro Tool Plus's will work together without conflict.

The iVAC Pro Switch integrates perfectly with all other iVAC Pro System components, to create a clever, modular system that you can adapt and expand over time.

Related components referred to in this manual:



Pro Blast Gate



NVR Switch



VFD (drive)

2.0 User Operation - iVAC Pro Switch DEC

2.1 Warnings - User Operation

- 2.1.1 Please read this Handbook before use. Retain for future reference.
- 2.1.2 The Pro Switch is intended for indoor use, in dry locations only.
- 2.1.3 When turning the Dust Extractor ON and OFF manually (by means of the Mode Switch), care should be taken not to exceed the cycle time specified by the Extractor manufacturer (cycling ON/OFF too quickly can damage some Extractors and Electronic Controllers).
- 2.1.4 Always isolate the Extractor when it is unattended (i.e. nights and weekends). Wireless interference to the Pro Switch could start the Extractor unexpectedly.
- 2.1.5 Always isolate the Extractor before servicing. Safe isolation is essential as the Extractor can be started by another person, remotely.

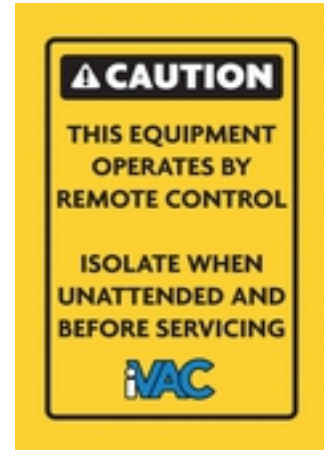

2.2 Pro Switch function

The iVAC Pro Switch is the component of the iVAC wireless Pro System that is used to control your Dust Extractor - e.g. turn it ON or OFF.

2.3 Mode Switch – 3 position rocker

The Mode switch is manually set to AUTO, OFF or ON.

AUTO The Pro Switch responds to wireless ON / OFF commands from Tool Plus and Remote units. The LED will flash and blink to indicate wireless activity (details in section 2.5)



ON Power will be supplied constantly to the Dust Extractor regardless of wireless commands from Tool Plus and Remote units. The LED will be ON constantly.

OFF Power is removed from the Dust Extractor regardless of wireless commands from Tool Plus and Remote units. The LED will be OFF constantly.

Note 1: When no USB Power is supplied to the Pro Switch, regardless of the Mode Switch position (AUTO or OFF or ON) The Pro Switch will have **no** impact on the Dust Extractor.

Note 2: When using the Mode Switch to manually control the extractor, the ON delay, OFF delays, Wait Until Extractor Stops and Minimum Run Time functions will **not** operate (see section 2.6). Avoid quick cycling ON & OFF as this could damage extractors and controllers.

2.4 AUTO Mode - Operation process

When set to AUTO, The Pro Switch receives and processes wireless ON / OFF commands from iVAC Remotes and Tool Plus's.

The Pro Switch records these ON / OFF commands into it's memory in preparation for turning your Dust Extractor ON or OFF.

NOTE: The first power tool to turn ON will start the Extractor, The last power tool to turn OFF will stop the Extractor

2.4.1 – Wireless ON commands

When the Pro Switch receives the **first** ON Command from any Remote or Tool Plus, it waits for 1.5 seconds and then starts the Dust Extractor. See *section 2.6.1*

2.4.2 – Wireless OFF commands

As the Pro Switch receives OFF commands from the active Tool Plus's or Remotes, it keeps the Extractor running until the **last** OFF command is received, then it waits a while before stopping the Extractor. See *section 2.6.2*

2.5 LED Indicator (V17 firmware – subject to change)

1. LED flashes 2 times at 1 Second intervals (approx 4 seconds). This is during the Pro Switch initial power up (*power-up reset - see section 2.6.5*)
2. LED blinks once every 4 seconds. Standby mode - power is applied (the Extractor is OFF)
3. LED is constant OFF. The Pro Switch has no power applied – it is off
4. LED is constant ON. The Pro Switch has turned the Dust Extractor ON and is waiting for a Tool Plus or Remote OFF command.
5. LED flashes at a steady rate of approx. 2 times per second. This is during the Minimum Run Time period (*see section 2.6.4*).
6. LED blinks at about 5 times per second. This is during the Delay OFF period – after the last OFF command was received until the extractor switches OFF (*see section 2.6.2*).
7. LED blinks twice and a short pause. (1) This is the Wait Until Dust Extractor Stops period - (*see section 2.6.3*) (2) This can also indicate that a power failure has occurred (*see NVR function - section 2.6.7*).

2.6 Functional Features Explained

2.6.1 Turn ON Delay Time

The Turn On Delay is to avoid two start-up power surges occurring at the same time on a supply circuit that is feeding both the Power Tool and the Dust Extractor. This function is to avoid tripping the main circuit breaker (overloading). The Turn On Delay time is factory set to 1.5 seconds.

2.6.2 Turn OFF Delay Time

The Turn OFF Delay is to allow the Dust Extractor to continue to run after a Power Tool has been turned off. This function is to clear up any remaining debris at the power tool and in the ducting. It may also be used to avoid quick (potentially damaging) cycling of the Extractor (details in section 3.3.1).

2.6.3 Wait until Dust Extractor Stops

This feature is provided for certain specific Dust Extractors that require the Dust Extractor Motor to completely stop before restarting (details in section 3.2).

2.6.4 Minimum Run Time

Larger Dust Extractors can be damaged if they are turned ON/OFF too frequently. The Pro Switch has the ability to make sure that the Dust Extractor runs for a Minimum Run Time. It can also be used for smaller Dust Extractors to avoid frequent cycling of the Dust Extractor motor (details in section 3.3.2).

2.6.5 Pro Switch Initial Power Up (when power is applied via USB)

Pro Switch Power Up Sequence:

1. The Pro Switch resets and clears it's memory.
2. The Pro Switch Ensures the relay contacts are open (the Extractor is OFF).
3. The LED lights 2 times (approx 4 seconds) to confirm it has reset.
4. The LED blinks once every 4 seconds – it is in standby, ready to operate.
5. The LED blinks twice and a pause – requires Mode switch moved to OFF.

NOTE: The Pro Switch has a safety feature (NVR) that prevents the Extractor turning ON if the mode switch is set to ON or AUTO when power is applied – see section 2.6.7

2.6.6 Master Reset

In today's environment there are many devices that use wireless radio frequency communications. In the unlikely event that the Pro Switch does not function correctly due to wireless interference, the Pro Switch can be **reset** by removing its power (e.g. by disconnecting its USB Power Supply) for 5 about seconds.

2.6.7 Power Failure Protection (NVR - No Voltage Release)

The Pro Switch will help to ensure that in the event of a power failure, your Extractor does not start up automatically when power is reinstated.

The Pro Switch has a safety feature that prevents the Extractor turning ON if the mode switch is set to ON or AUTO when USB power is applied

How this works depends on the position of the Mode Switch when the power failure occurred:

AUTO The Dust Extractor will only turn ON when a wireless ON command is received from a Tool Plus or Remote.

ON The Dust Extractor will remain OFF (LED blinks twice and a pause). To turn the Dust Extractor ON the Mode Switch must be first moved to OFF and then back to ON

OFF The Dust Extractor will remain OFF

For this feature to operate correctly, the Pro Switch USB power supply and the Dust Extractor should be on the same supply circuit.

NOTE Your Extractor will be factory fitted with a switch or NVR, these should be left in circuit and operational. The Pro Switch is installed in **addition** to these.

2.7 Physical Features



Access panel to DIP switches.
Located on the rear of the enclosure. PH1 screwdriver required.



Earth (ground) terminal.
Can be used to earth equipment and ducting.

3.0 Configuration – Pro Switch Programmable features

The following features and settings are programmed by means of the DIP Switches accessible through the access cover in the Pro Switch base.
(PH1 screwdriver required).

Programmable features (set by DIP switch) :

- One of four System ID's (addresses)
- Wait for Dust Extractor to stop
- One of four Turn OFF delays
- One of four Minimum Run Time settings



DIP switches – for programming the Pro Switch.
All shown positioned OFF factory setting.

Note: Any changes to the program DIP switches are only saved into the Pro Switch's memory when the Mode Switch is in the OFF position OR when the Pro Switch power (USB) is removed.

Once you have configured your Pro Switch and related iVAC components, you can apply the labels from the supplied sheet. Labelling your iVAC components helps identify them for future reference.



A, B, C & D for your Pro Switch(s) to identify the programmed System ID (address)
A1 - A8, B1 - B8, C1 - C8, D1 - D8, for your Transmitters and Blast Gates
CAUTION goes onto your extractor

3.1 System ID (Address)

There are four System ID's (Addresses), this enables up to four iVAC systems to operate independently while within the same workshop (e.g. Within communication range of each other). Typically one Pro Switch controls one Extractor.

The Pro Switch can be assigned to work on one of the four System ID's (Addresses) - A, B, C or D. This is done with DIP Switches 1 & 2.

For the iVAC Pro Switch, Tool Plus, Remote and Blast Gate components to work together as a 'system' they must **all** be set to the same System ID (Address).

System Address	S1	S2
A (factory setting)	Off	Off
B	On	Off
C	Off	On
D	On	On

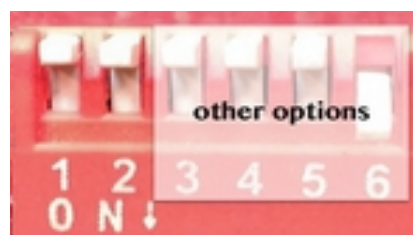

3.2 Wait until Dust Extractor Stops

This feature is provided for certain Dust Extractors (and / or VFD drives) that require the Dust Extractor Motor to completely **stop** before restarting.

Refer to your Dust Extractor and VFD Manuals to see if this function is required (It is most likely **not** required for smaller Dust Extractors - 3000 watts or less).

When S3 is in the on Position, the Pro Switch will wait 30 seconds after it has turned OFF the Dust Extractor before it will turn the Dust Extractor ON again.

ON commands from any Pro Tool Plus or Remote components will be saved by the Pro Switch and acted upon when this 30 second delay is complete.

During this period the LED will repeat a pattern of blinking twice and a short pause.

S3	Wait until Dust Extractor Stops
Off	0 (factory setting)
On	30 seconds

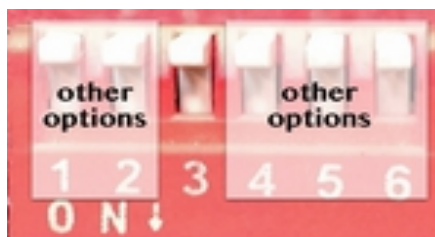

3.3 Turn OFF Time Delay and Minimum Run Time

3.3.1 Turn OFF Time Delay

This feature is to allow the Dust Extractor to continue to run after a power tool has been turned OFF, clearing up any remaining debris at the power tool and in the ducting. It may also be used to avoid quick (potentially damaging) cycling of the Dust Extractor.

This is the delay time period from when the Pro Switch receives an OFF command from the last active Remote or Tool Plus.

The OFF Time delay can be programmed to: 0, 5, 15, or 45 seconds

During the Turn OFF Time delay period the LED will blink at a rate of 5 times per second.

3.3.2 Minimum Run Time

This feature is intended for larger Dust Extractors (typically those greater than 3000 watts) however it can also be used for smaller Dust Extractors to avoid frequent cycling of the Dust Extractor motor.

Larger Dust Extractors can be damaged if they are turned ON/OFF too frequently.

The Pro Switch records the time that the Dust Extractor was turned ON and ensures that the Dust Extractor runs for at least the Minimum Run Time before turning it OFF.

The Minimum Run Time can be programmed to: 5 seconds, 2, 4, or 8 minutes.

For example if the Minimum Run Time setting is for 8 Minutes , and the Pro Switch receives an Off Command after only 3 minutes, it will wait for another 5 minutes before turning off the Dust Extractor.

If the Pro Switch receives an OFF Command after the Minimum Run Time is met, then the Pro Switch will delay by the OFF Delay Time before turning off the Dust Extractor.

During the Minimum Run Time period the LED will flash at a rate of 2 times per second.

S4	S5	S6	Off Delay Time	Min Run Time
Off	Off	Off	5 seconds (factory setting)	0
Off	On	Off	15 seconds	0
Off	Off	On	45 seconds	0
Off	On	On	0	0
On	Off	Off	5 seconds	5 seconds
On	On	Off	1 MINUTE	2 MINUTES
On	Off	On	1 MINUTE	4 MINUTES
On	On	On	1 MINUTE	8 MINUTES



4.0 Installation – Pro Switch

It is advisable to configure, test and label your Pro Switch (and related Pro System components) before connection to the Extractor or VFD is made. Ideally, layout and configure all your Pro System components on a bench and confirm correct operation before installation of the components to their final locations. When testing, you will hear the Pro Switch internal relays clicking on and off and see the LED indicating.

4.1 Warnings - Installation

- 4.1.1 Please read this Handbook before installation and use. Retain for future reference.
- 4.1.2 The iVAC Pro Switch is intended for indoor use, in dry locations only.
- 4.1.3 The iVAC Pro Switch should only be powered by the supplied USB 5V DC Power Supply.
- 4.1.4 Connections between the Pro Switch and the Dust Extractor or VFD should be made by a competent, experienced person (i.e. a qualified electrician) due to electrical shock hazard and / or risk of damage to the equipment.
- 4.1.5 Always connect the Extractor and Pro Switch USB to the same supply circuit – this ensures correct operation of the Pro Switch NVR feature, *see section 2.6.7.*
- 4.1.6 Check the specifications of the Extractor / VFD to establish if Minimum Run Time and Wait until Extractor Stop features are required, *see section 3.0.*
- 4.1.7 Always isolate the Extractor before servicing. Safe isolation is essential as the Extractor can be started by another person, remotely.
- 4.1.8 Apply the supplied warning label to the Extractor. This ensures that users and service personnel know that the Extractor can be controlled remotely.

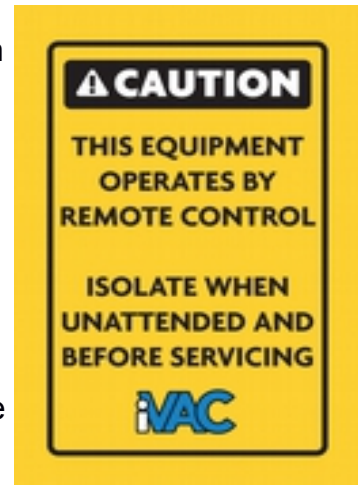

4.2 Pro Switch Mounting and Location

A socket outlet is required near the Pro Switch for the supplied USB power supply.

Four mounting lugs are provided for mounting. Fasten the Pro Switch firmly to a flat surface (ideally vertical) that is **not** subjected to excessive vibration or dust.

When mounting the Pro Switch (and other iVAC Pro System components) they should **NOT** be mounted onto, or close to, large metal objects, since this can reduce the operational wireless range between the Pro System components.

The wireless RF range of forty feet is based on line of sight communications. Wireless communications through walls and objects may reduce the forty foot range.

4.3 Electrical Connections - General Information

Here we provide general information and guidance relating to the electrical connections of the Pro Switch to a Dust Extractor **OR** Controller (e.g. VFD).

The electrical configuration and connections should only be made by an experienced and competent person (e.g. a qualified electrician).

Incorrect application, installation and connections could damage your equipment and void your Pro Switch warranty.

Your Extractor will be factory fitted with a Switch or NVR, these should be left in circuit and operational. The Pro Switch is installed in **addition** to these.

The Pro Switch **must** be earthed. The Green / Yellow wire needs to be connected to a reliable earth.

Inside the Pro Switch Enclosure

The switching function of the Pro Switch is performed by its two heavy duty relays, these relays are switched ON and OFF by the Pro Switch circuitry. Both relays are normally open (NO) contacts and switch together.

The 4 switching wires (2 wire pairs) of the Pro Switch are only connected to the dry contacts of the two relays inside the Pro Switch - there is **NO** voltage applied to these wires by the Pro Switch.



Product variations exist.
For illustration only.

Wire colours:

- White and Red pair, connected to relay **1** (NO contacts)
- Black and Green pair, connected to relay **2** (NO contacts)
- Green / Yellow, Earth (ground)

The two relays within the Pro Switch DEC are always switched together - they are **both** either ON or OFF.

- The relay contacts are **closed** to provide power to the Dust Extractor.
- The relay contacts are **opened** to remove power from the Dust Extractor.

4.4 Relay Wiring – Illustration & Explanation

The 4 switching wires of the Pro Switch are connected to the two relays within the Pro Switch. Each relay has one set of Normally Open (NO) Contacts.

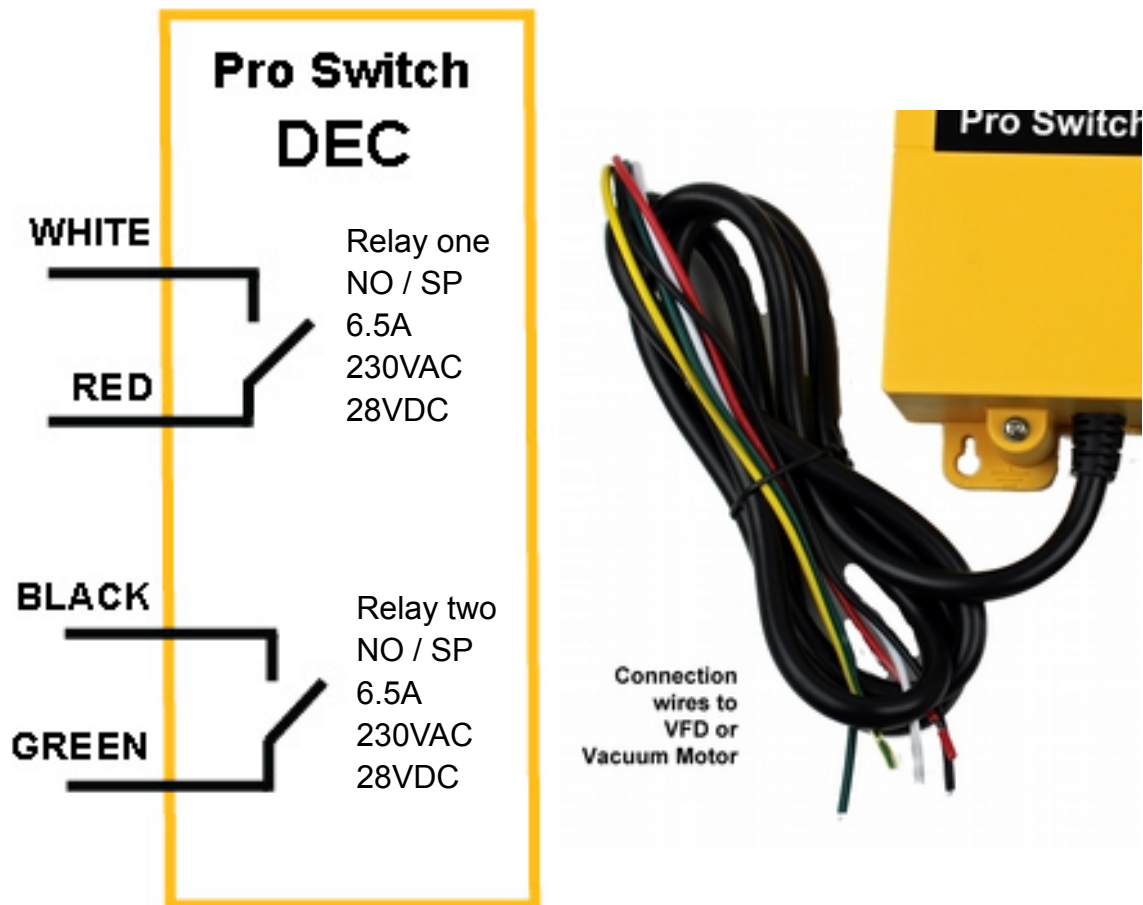

The 4 switching wires (white / red pair and black / green pair) of the Pro Switch are directly connected to the dry contacts of the two relays inside the Pro Switch.

There is NO voltage applied to these wires by the Pro Switch.

The 5th wire, coloured green / yellow, is the earth and must be connected to a reliable earth during installation.

4.5 Connection options

The DEC Pro Switch can be used to control an Extractor in two ways:

1. Directly switching the AC power to the Dust Extractor motor (e.g. 230V AC) see section 4.6 for further information
2. Providing digital input signals to a VFD motor drive (e.g. 24V DC) see section 4.7 for further information

4.6 Direct Switching (single phase motors only)

The Pro Switch DEC can be used to control a Dust Extractor motor by means of it's two relays. The relay contacts can switch the power to the Extractor motor.

Where an NVR is installed by the Extractor manufacturer, The switching of the power by this Pro Switch takes place before the motor and **after** the NVR

In many cases, these connections can be made inside the enclosure of the NVR or Switch provided by the Extractor manufacturer.

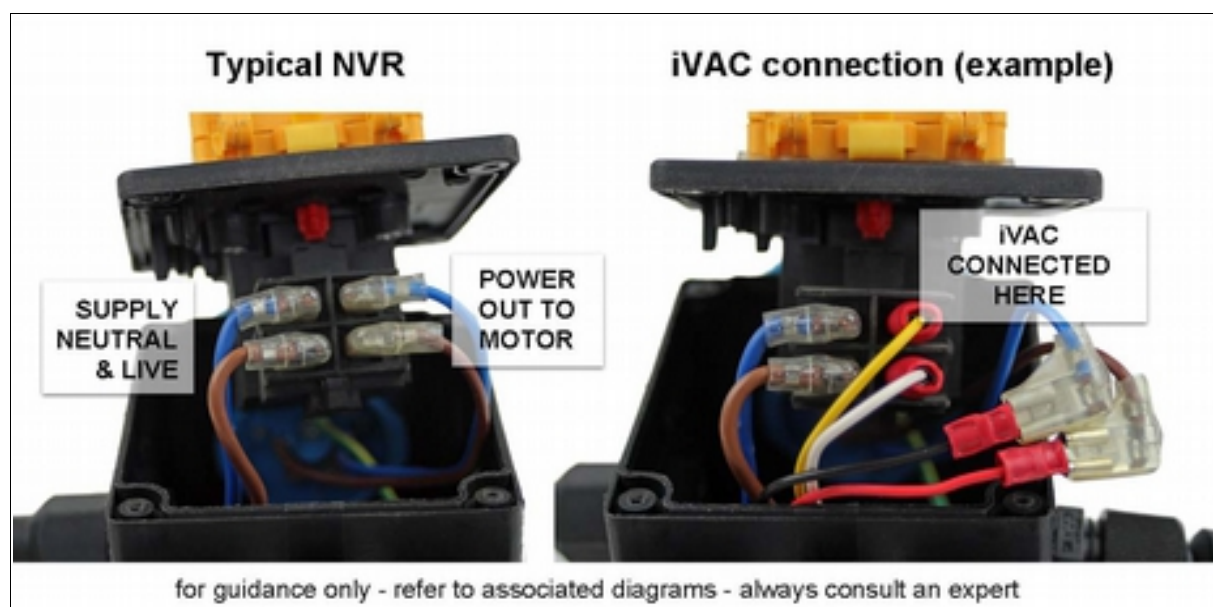

NOTE - picture shows double pole application – max 1500 watts – see 4.6.2

The relay contacts can be utilised for single pole **or** double pole switching - see 4.6.1 and 4.6.2 on the next page.

It is important to ensure that the correct overload protection (fuse or circuit breaker) is provided to protect the Pro Switch, the Extractor and cabling. The type and level of overload protection is decided by the installer. There is no overload protection provided by the Pro Switch itself.

4.6.1 Single Pole (maximum power – 3Kw / 230V)

When connected in parallel, the two relays can be used to switch only the Live power lead to the Dust Extractor motor.

In this configuration, 230V Dust Extractors up to **3000 watts (3HP)** can be controlled.

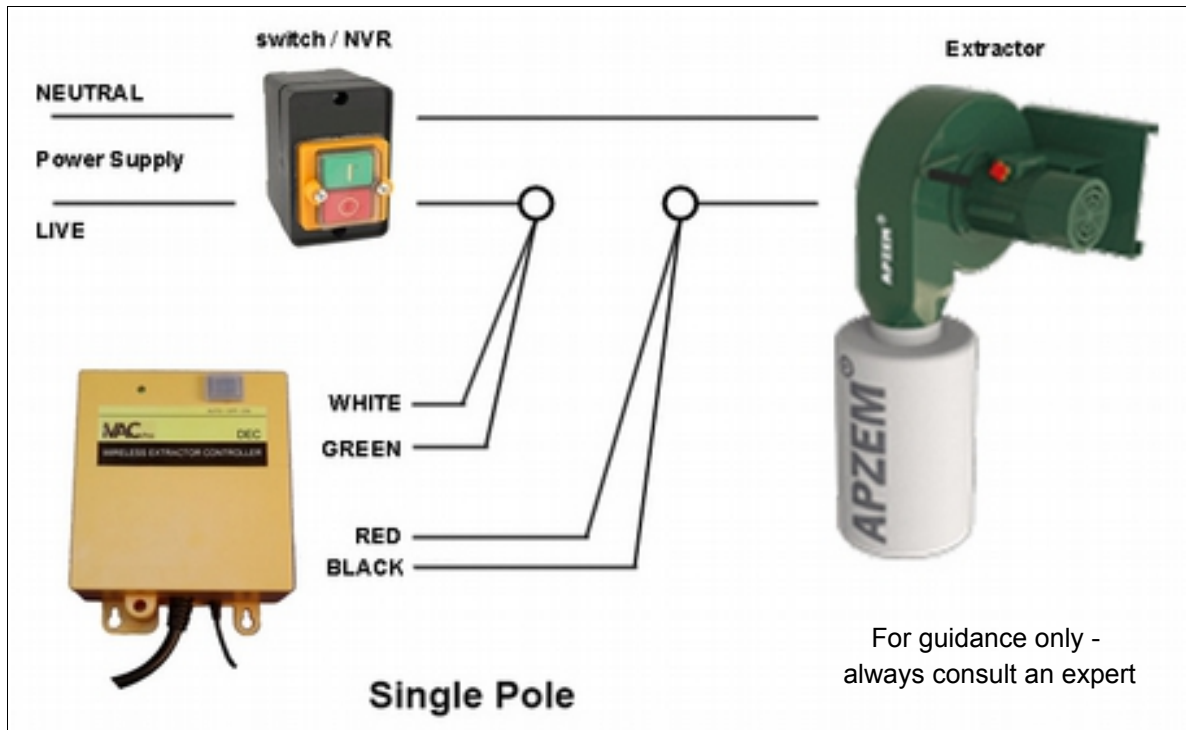

4.6.2 Double Pole (maximum power – 1.5Kw / 230V)

As individual contacts the two relays can be used to switch both the Live and Neutral power leads to the Dust Extractor motor.

In this configuration, 230V Dust Extractors up to **1500 watts (1.5HP)** can be controlled.

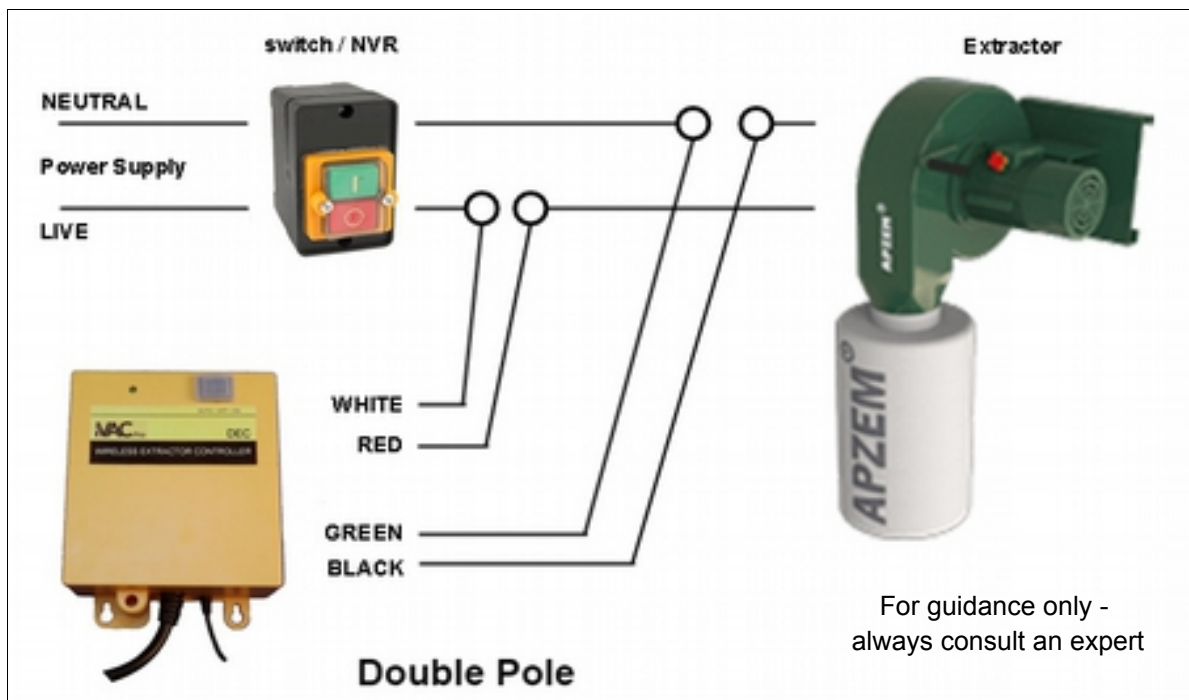

4.7 Digital Input Control (e.g. VFD - Variable Frequency Drive)

Dust Extractors with electronic controllers (e.g. VFD / Motor Drive) can usually be controlled by means of a digital signal input or contact closure.

The Pro Switch DEC could be connected to a VFD as shown in the example below.

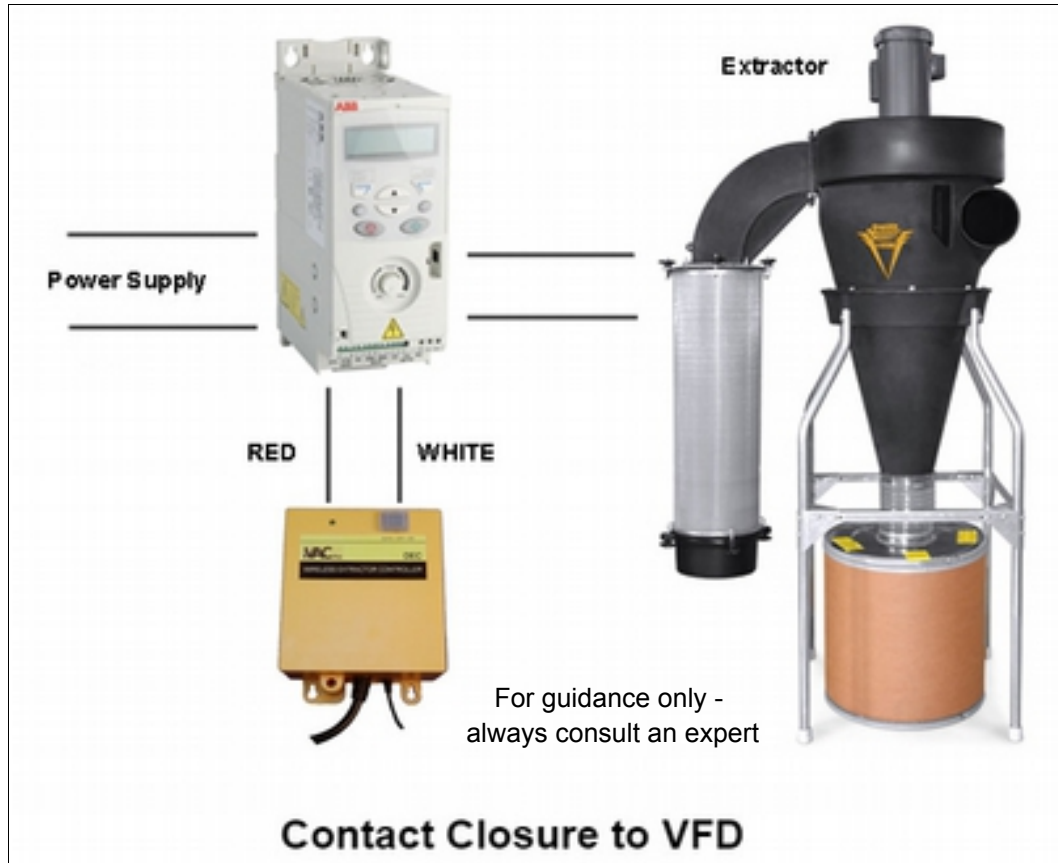

In this situation, typically only one wire pair (one relay) from the Pro Switch is required.

Expert knowledge of the controller (e.g. VFD) is required to ensure correct connections and configuration.

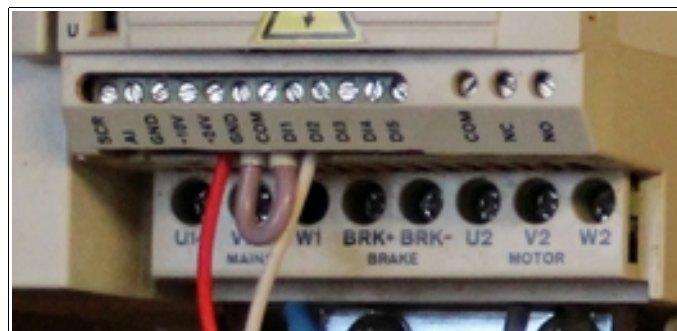

Product variations exist - For illustration only.
VFD's require expert configuration to suit application and equipment.

5.0 Warranty

This iVAC Pro Switch is guaranteed against defects in materials and workmanship, under normal usage, for one year from the date of purchase. This guarantee is not transferable and does not affect your statutory rights. This guarantee **does not apply** in cases of incorrect installation or connection, improper use, negligence, lack of maintenance or accidental damage. Under the terms of this guarantee, a faulty iVAC Pro Switch will either be repaired or replaced free of charge. Liability is limited to the iVAC Pro Switch only, no other costs will be reimbursed. This guarantee does not confer any rights other than those expressly set out above.

6.0 Service and Repairs

Your iVAC Pro Switch will give many years of reliable service. In the event of damage or a fault you can return the Pro Switch to our UK workshop for repair. We will provide an estimate for repairs once the Pro Switch has been inspected.

There are no user serviceable parts in the enclosure.

7.0 Specifications

Product part number – 15567-201 (5 wire)
Housing - 5" (128mm) wide x 7" (177mm) high x 2" (52mm) deep.
Housing - ABS 94V0 plastic - yellow
Environment - Indoor, dry locations only - 0C to 30C.
Protection - IP20 - Class I - (Requires earthing)
Power handling - Single pole configuration – 3000 watts max, 230V (see 4.6.1)
Power handling - Double pole configuration – 1500 watts max, 230V (see 4.6.2)
Internal relays (X2) - normally open contacts, single pole switching.
Relay contacts – Each, maximum 6.5 Amp, 240V AC / 28V DC.
USB power supply - input: 100-240Vac 50/60Hz. output: 5Vdc 1A (supplied).
USB power lead - approx 1.8 metres long.
Pro Switch switching connection lead - approx 1.3 metres long.
Wireless - 433Mhz proprietary digital signalling (secure).
Wireless range - approx forty feet / 12 metres, line of sight.
Turn ON delay time - 1.5 seconds.
Turn OFF delay time - 0 sec, 5 secs, 15 secs, 45 secs, – Programmable.
Minimum Run Time - 5 secs, 2 minutes, 4 minutes, 8 minutes – Programmable.
Wait until Dust Extractor Stops - 0 or 30 seconds – Programmable.
Approvals - CE. RoHS.
Manufactured by BCTINT (ROC)

Firmware installed:

Version
date

8.0 Contact

United Kingdom - Toolovation

www.toolovation.co.uk

ivac@toolovation.co.uk

01531 636819



Canada (head office) - iVAC

www.ivacswitch.com

info@ivacswitch.com

