

# 15.5 Ft x 8 Ft Apex Pro

(EN) VINYL GARDEN SHED

(ES) JARDÍN DE VINILO CUBIERTO

(FR) ABRI DE JARDIN DE VINYLE

(EN) Model # 40216  
(ES) Modelo # 40216  
(FR) Modèle # 40216



**(EN) OWNER'S MANUAL /**

Assembly Instructions '15.5 Ft Apex Pro'

Size 15.5 Ft x 8 Ft / 4.8 m x 2.4 m (Approx.)

Ver: 0.0

*Please thoroughly read the owner's manual before beginning the shed assembly.*

*Call us for any missing or damaged parts.*

*Do not return to the store.*



You can watch the assembly videos on [www.duramaxbp.com](http://www.duramaxbp.com)

*Need Help? Comments or Suggestions  
Call Customer Service Hotline.*

**(800) 483-4674**

[www.duramaxbp.com](http://www.duramaxbp.com)

## WARRANTY ACTIVATION

Thank you for your purchase of DURAMAX shed. To activate your shed warranty, log on to our website and fill in the form under warranty activation.

[www.duramaxbp.com/warranty.php](http://www.duramaxbp.com/warranty.php)

**(ES) MANUAL DEL PROPIETARIO /**

Instrucciones de montaje '15.5 Pies Apex Pro'

Tamaño 15.5 Pies x 8 Pies / 4.8 Metros x 2.4 Metros (Aproximado.)

Ver: 0.0

*Por favor a fondo lea el manual del dueño antes de comenzar la asamblea de cobertizo.*

*Llámenos para cualquier perder o partes dañadas.*

*No vuelva a la tienda.*



Usted puede ver los videos de montaje en [www.duramaxbp.com](http://www.duramaxbp.com)

*necesita ayuda? Comentarios, Sugerencias?  
La Línea Directa del Servicio del cliente.*

**(800) 483-4674**

[www.duramaxbp.com](http://www.duramaxbp.com)

## ACTIVACIÓN DE GARANTÍA

Gracias por su compra de DURAMAX cobertizo usted. Para activar la garantía cobertizo, ingrese a nuestra página web y rellenar el formulario en la activación de la garantía.

[www.duramaxbp.com/warranty.php](http://www.duramaxbp.com/warranty.php)

**(FR) GUIDE D'INSTRUCTIONS /**

Instructions de montage '15.5 Pieds Apex Pro'

Mesures 15.5 Pieds x 8 Pieds / 4.8 Mètre x 2.4 Mètre (Approximatif.)

Ver: 0.0

*Veillez lire attentivement le mode d'emploi avant de commencer l'assemblage de remise.*

*Appelez-nous pour toute les pièces manquantes ou endommagées.*

*Ne pas retourner au magasin.*



Vous pouvez regarder les vidéos de montage sur [www.duramaxbp.com](http://www.duramaxbp.com)

*a besoin d'aide? Commentaires, suggestions?  
Hotline service client.*

**(800) 483-4674**

[www.duramaxbp.com](http://www.duramaxbp.com)

## ACTIVATION DE LA GARANTIE

Merci pour votre achat de DURAMAX hangar. Pour activer la garantie de votre hangar, connectez-vous sur notre site et remplir le formulaire sous activation de la garantie.

[www.duramaxbp.com/warranty.php](http://www.duramaxbp.com/warranty.php)

**(EN) Your Total Solution To Maintenance Free Storage Sheds.**

- All Weather Durable PVC
- Won't Dent, Rust, Rot or Mildew
- Tall Walk In Shed
- Never Needs Painting
- 61 Inch Wide Double Doors
- Easy Assembly
- High Wind Tested
- Snow load tested 18 lbs/sq.foot
- Pad Lock Ready (Lock not included)
- Foundation frame kit included, Wood or Cement floor needed
- Shatter Proof Window included

**(ES) Su solución total para mantenimiento de cobertizos de almacenamiento gratuito.**

- PVC durable todo clima
- No se abolla, oxida, no tiene corrosión o moho
- La Caminata alta en la Barraca
- No necesita pintura
- puertas dobles anchas de 61 pulgadas
- la Asamblea Fácil
- Probado contra el fuerte viento
- Carga de nieve probado 18 LBS/sq.Foot.
- Cierre con candado (Cierre no incluido)
- Kit de Fundación marco incluido, madera o cemento necesario
- Ventana irrompible incluida

**(FR) Votre solution pour un abri de jardin sans entretien.**

- Solidité Assurée en Toute Saison
- Ne se cabosse pas, ne rouille pas, ne moisit pas et ne se pique pas
- Déplacement en position debout dans l'abri
- Pas besoin de peinture
- Grandes doubles portes de 61"
- Montage facile
- Testé contre les vents violents (structure fixée au sol suivant les recommandations).
- Charge de neige testé 18 lbs/sq.Foot.
- Possibilité d'ajouter un cadenas (Verrou non inclus)
- Kit cadre de fondation inclus, Obligation de poser cet abri sur des fondations en béton ou en bois.
- Fenêtre incassable incluse

**(EN) Building Dimensions:**

Approximate Size	Storage		Exterior Dimension				Interior Dimension		Door Opening		
	Area	Volume	Base Dimension		Roof Edge to Edge		Wall to Wall				
			inch	cm	inch	cm	inch	cm			
15.5 Ft x 8 Ft	118 7/8 Sq. Ft	723 1/4 Cu.Ft	Width	187 5/8	476.7	190 5/8	484.2	185 1/2	471.3	60 5/8	154
4.8 m x 2.4 m	11.04 Sq.m	20.48 Cu.m	Depth	94 3/8	239.7	97 1/4	247.3	92 1/4	234.3		
			Height			92 1/4	234.7	73	185.5	71 1/2	181.5

**(ES) Dimensiones del edificio:**

El Tamaño aproximado	Área de almacenaje		Dimensión exterior				Dimensión interior		Abertura de la puerta		
	Área	Volume	Dimensión de la base		Borde de la azotea al borde		pared a pared				
			Pulgada	cm	Pulgada	cm	Pulgada	cm			
15.5 Pies x 8 Pies	118 7/8 Pies cuadrados	723 1/4 Pies Cúbicos	Anchura	187 5/8	476.7	190 5/8	484.2	185 1/2	471.3	60 5/8	154
4.8 Metros x 2.4 Metros	11.04 Metros cuadrados	20.48 Metros Cúbicos	Profundidad	94 3/8	239.7	97 1/4	247.3	92 1/4	234.3		
			Altura			92 1/4	234.7	73	185.5	71 1/2	181.5

**(FR) Dimensions du bâtiment:**

Taille approximative	Stockage		Dimension extérieure				Dimension intérieure		Ouverture de porte		
	Secteur	Volume	Dimension de base		Toit de bord au bord		Mur à mur				
			pouce	cm	pouce	cm	pouce	cm			
15.5 Pieds x 8 Pieds	118 7/8 Carré pieds	723 1/4 Pieds cube	Largeur	187 5/8	476.7	190 5/8	484.2	185 1/2	471.3	60 5/8	154
4.8 Mètre x 2.4 Mètre	11.04 Mètre carré	20.48 Mètre cube	Profondeur	94 3/8	239.7	97 1/4	247.3	92 1/4	234.3		
			Hauteur			92 1/4	234.7	73	185.5	71 1/2	181.5

## (EN) Duramax Vinyl Garden Shed

### Limited Fifteen Year Warranty

U.S. Polymer Inc. will send a replacement part free of charge, in the event of material defects and or workmanship for a period of fifteen years from the date of purchase. In the event of a defect covered by the warranty, U.S. Polymers shall replace the defective part, but shall not be responsible for shipping, labor or other charges.

This warranty is extended only to the original purchaser. A purchase receipt or other proof of date of original purchase will be required before warranty service is rendered. In no event shall we pay the cost of flooring, labor, installation or any other costs related thereto.

This warranty only covers failures due to defects in material or workmanship which occurs during normal use and does not extend to color change arising due to normal weathering or to damage resulting from misuse or neglect, commercial use, failure to follow assembly instructions and the owner's manual (including proper anchoring of the shed), painting, forces of nature and other causes which is beyond our control.

Claims under this warranty must be made within the warranty period by calling 1-800-483-4674 or mail in a dated sales slip and clear photograph to:

U.S. Polymers Inc., 10575 S. Valley Ave, Montebello, CA 90640, United States of America.

We reserve the right to discontinue or change components. If a component has been discontinued or is not available,

U.S. Polymers, Inc. reserves the right to substitute a component of equal quality as may be compatible.

#### Limits and Exclusions

There are no express warranties except as listed above. The warrantor shall not be liable for incidental or consequential damages resulting from the use of this product, or arising out of any breach of this warranty. All express warranties are limited to the warranty period set forth above. Some states do not allow exclusion or limitation on how long an implied warranty lasts, so the above limitations may not apply to you.

This warranty gives you specific legal rights and you may also have other rights which vary from state to state or country to country.

## (ES) Jardín De Vinilo Cubierto Duramax

### Garantía Limitada durante 15 años

U.S. Polymer Inc. enviará una pieza de recambio sin coste alguno en caso de defectos de fábrica o en los materiales durante un periodo de 15 años a partir de la fecha de adquisición. En caso de que un defecto esté cubierto por la garantía, U.S. Polymers deberá reemplazar la parte defectuosa pero no es responsable del envío, mano de obra u otros cargos.

Esta garantía se aplica únicamente al comprador original. Es necesario presentar un recibo u otra prueba de compra antes de prestar los servicios especificados en esta garantía. En ningún caso se sufragará el coste de la instalación de suelos, mano de obra, instalación o cualquier otro gasto relacionado.

Esta garantía cubre exclusivamente los defectos de fabricación o en los materiales que aparecen durante el uso habitual y no se aplica a los cambios de color causados por la exposición normal a los elementos o a daños ocasionados por un uso inapropiado o negligente, usos comerciales, no seguir las instrucciones de montaje o el manual del propietario (incluyendo el correcto anclaje del cobertizo), aplicación de pintura, causas naturales o cualquier otra ajenas a nuestro control.

Las reclamaciones cubiertas por la presente garantía pueden efectuarse dentro del periodo de garantía llamando al teléfono 1-800-483-4674 o por postal con una prueba de compra fechada y una fotografía a nitida de la pieza dañada:

U.S. Polymers Inc., 10575 S. Valley Ave, Montebello, CA 90640, United States of America.

Nos reservamos el derecho a abandonar la fabricación de un componente o cambiarlo. En caso de no continuar fabricando un componente o no estar éste disponible, U.S. Polymers, Inc. se reserva el derecho a sustituirlo por otro componente de idéntica calidad que sea compatible.

#### Límites y Exclusiones

No existe ninguna garantía expresa más allá de las indicadas anteriormente. El garante no aceptará ninguna responsabilidad por daños incidentales o emergentes ocasionados por el uso de este producto o por cualquier infringement de esta garantía. Todas las garantías expresadas se aplican al periodo de garantía anteriormente señalado. Algunos estados no aceptan exclusiones o limitaciones en la duración de las garantías implícitas, por lo que las limitaciones anteriormente expresadas pueden no ser de aplicación para usted.

Esta garantía otorga derechos legales específicos. Usted puede disfrutar también de otros derechos que pueden ser diferentes para cada estado o país.

## (FR) Duramax abri de jardin en vynile

### Garantie Quinze Ans

U.S. Polymer Inc. remplacera sans frais toute pièce en cas de défaut de fabrication ou de matière pour une période de quinze ans (A compter de la date d'achat). Dans le cas d'un défaut couvert par la garantie, U.S. Polymers remplacera la pièce défectueuse, mais ne sera pas responsable de l'expédition, de main-d'œuvre ou d'autres frais.

La garantie est seulement étendue à l'acheteur original. Une facture d'achat ou autre preuve confirmant la date de transaction sera exigée avant que le service de garantie vous soit accordé. Nous ne rembourserons aucun frais liés à l'achat des fondations, de main-d'œuvre, d'installation ou tout autre coût extérieur à la garantie.

La garantie s'applique contre tous défauts de fabrication ou de matière dès lors que l'installation est conforme aux préconisations du fabricant décrites dans la notice d'assemblage, à l'exception d'une mauvaise utilisation, de l'usure, d'une décoloration liée aux intempéries, d'une utilisation commerciale et d'incidents matériels extérieurs concernant le dit produit.

Toutes réclamations doivent être faites durant la période de garantie en téléphonant au 1-800-483-4674 ou en expédiant une facture d'achat et photographiée de la pièce à :

U.S. Polymers Inc., 10575 S. Valley Ave, Montebello, CA 90640, United States of America.

Nous nous réservons le droit d'annuler ou de changer les pièces si l'une des pièces a été arrê-tée ou n'est plus disponible. U.S. Polymers Inc. se réserve le droit de changer une pièce de qualité égale à la pièce d'origine.

#### Limitation et Exclusions

Il n'y a d'autre garantie exceptée celle mentionnée ci-dessus. Le garant n'est pas responsable des dégâts matériels ou des accidents consécutifs à une installation non conforme aux dispositions légales et réglementaires du pays de mise en service. En aucun cas, cette garantie ne donne droit à des indemnités ou à des dommages et intérêts. Toutes garanties sont limitées pour une période mentionnée ci-dessus certains pays ne permettent pas la limitation et l'exclusion concernant la durée de garantie, ceci pourrait donc ne pas s'adresser à vous.

Cette garantie vous donne des droits légaux spécifiques et vous pourriez aussi avoir d'autres droits qui varient d'un pays à l'autre.

## (EN) SAFETY & PRECAUTIONS

For your own safety, please read and follow these instructions during the shed assembly.

### Before You Begin...

1. Check your local building codes regarding footings, location, etc.
2. Select a site that allows enough working space around the shed.
3. Determine building foundation and anchoring system.
4. Read and understand the Owner's manual enclosed in the package.
5. Follow all directions and dimensions thoroughly.
6. Follow the steps given in the manual carefully for correct assembly.
7. Make sure all parts are present before you start assembling.
8. **BE SAFE** Follow safety instructions and avoid injury. (See inside page).
9. **GROUND MUST BE EVEN** Make sure the foundation frame lies flat on the ground. If the earth bed is uneven, remove sod and other debris and level it with a flat shovel.
10. Separate contents of the carton by the part number and review the list. Be sure you have all the necessary parts for your shed. Refer to Owner's manual for part list.



### Safety First !

1. Always wear work gloves, long sleeves and eye protection during assembly of the shed. Some pieces of the shed contain sharp edges and can cause injury.
2. Be cautious with the tools used for the assembly of the shed. Familiarize yourself with the operation of all the power tools.
3. Children and pets should be kept away from the assembly site to avoid any distractions and accidents.
4. When using a step ladder, make sure it is on even ground and fully open with the safety latch in place. Never concentrate your full weight on the roof or any part of the shed.
5. Do not attempt to assemble the shed on a windy day. Shed panels can be whipped across by the wind making the worksite difficult and dangerous.

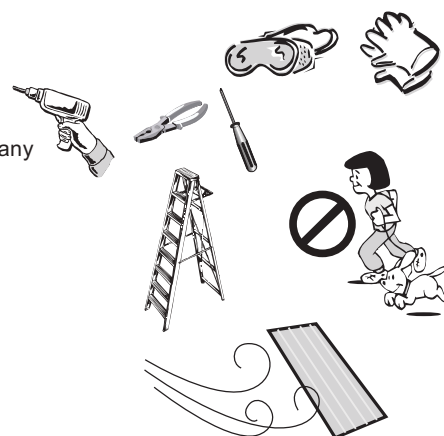

### Important

- Wear eye protection when using any form of power tools. Do not use voltage power tools in a wet or damp environment to avoid electric shock.
- Do not use any part of the shed as a means of personal support while attaching components during assembly.
- The shed must be constructed on a solid base foundation.** A concrete pad or large size concrete patio stone squares is recommended for suitable floor base. Make sure it is firm and level and will allow drainage away from the site. The base foundation should be at least 4 inches (100 mm) larger than the shed dimensions. Please refer to the front page of your owner's manual for the exterior dimensions of the shed. **Manufacturer is not responsible for the choice and construction of the foundation.**
- For a concrete pad base, prepare a level bed for a firm footing layer of crushed stone. The concrete pad should then be poured to a thickness of 4 inches (100 mm) to 5 inches (125 mm). Allow to dry thoroughly for at least 48 hours.
- Your shed must be firmly anchored to the concrete pad or large concrete patio stone squares, to help protect against damage in high winds.

### Care & Maintenance

Although this unit does not require any maintenance, care should be taken to prolong the life of your shed. It is for one time assembling and set up, no purpose of re-using.

**ROOF:** Keep roof clean of leaves and snow with long handled, soft bristled broom. Heavy amounts of snow on the roof can damage the shed making it unsafe. "Do not walk on roof surfaces! Risk of falling!"

**WALLS:** Do not rest any object against the wall panels of the shed.

**DOORS:** Keep doors closed to prevent wind damage.

**FASTENERS:** Regularly check your shed for loose screws, bolts, nuts, etc. and retighten them as necessary.

**MOISTURE:** With changing temperatures, condensation will accumulate inside the shed. Good ventilation will help in regulating and avoid moisture.

**TIP:** A noncorrosive caulking is helpful to seal the shed.



**DO NOT** store Inflammable, Hazardous and Swimming pool chemicals in your building. Combustibles and corrosives must be stored in air tight containers. Enforce **NO SMOKING.**



## (ES) SEGURIDAD Y PRECAUCIONES

Para su propia seguridad, lea y siga las instrucciones durante el ensamblaje y el cobertizo.

### Antes de comenzar ...

1. Consulte los códigos de construcción locales relativos a cimentación, localización etc.
2. Seleccione un sitio que permite suficiente espacio para trabajar alrededor de la nave.
3. Determine la fundación de la construcción y sistema de anclaje.
4. Lea y entienda el manual de instrucciones incluido en el paquete.
5. Siga las indicaciones y dimensiones exhaustivamente.
6. Siga los pasos indicados en el manual para un montaje correcto.
7. Asegúrese de que no le falte ninguna pieza antes de empezar el montaje.
8. **SEA SEGURA** : Para evitar lesiones siga las instrucciones de seguridad. (Véase página interior).
9. **EI SUELO DEBE SER NIVELADO** : Asegúrese de que el marco de la base quede plano en el suelo. Si la base del suelo está desnivelado se recomienda que quite césped y otros escombros y lo nivele con una pala plana.
10. Disponga del contenido de la caja según numeración de las partes, revisando la lista. Asegúrese de que no le falte ninguna pieza para el montaje de su cobertizo. Consulte el manual del propietario para revisar el nombre de las piezas.



### Safety Primero !

1. Use siempre guantes de trabajo, mangas largas protección ocular durante el montaje de la nave. Algunas piezas de la nave tienen bordes afilados y pueden causar lesiones.
2. Tenga cuidado con las herramientas utilizadas para el montaje de la nave. Familiarícese con el funcionamiento de todas las herramientas eléctricas.
3. Los niños y los animales domésticos deben mantenerse alejados de las instalaciones de ensamblaje para evitar cualquier distracción o accidente.
4. Cuando se utiliza una escalera de tijera, asegúrese de que esté sobre un fondo plano y completamente abierto con el pasador de seguridad en su lugar. Nunca concentre todo su peso sobre el techo o cualquier parte de la nave.
5. No intente montar el cobertizo durante un día ventoso. Los paneles de cobertizo pueden ser azotados a través por el viento que hace las obras difíciles y peligrosas.



### Importante

- Use protección ocular cuando utilice cualquier tipo de herramientas eléctricas. No utilice herramientas de tensión en un ambiente húmedo o mojado para evitar descargas eléctricas.
- No utilice ninguna parte de la nave como un medio de apoyo personal mientras coloca los componentes durante el montaje.
- La vertiente se debe construir en una fundación sólida.** Un cojín concreto o los cuadrados concretos del tamaño grande de una piedra del patio se recomiendan para la base conveniente para el suelo. Asegúrese de que sea firme y llana y que permita drenaje lejos del sitio. La fundación baja debe ser por lo menos de 4 pulgadas (100mm) más grande que las dimensiones de la vertiente. Refiera por favor a la página delantera del manual de su dueño para las dimensiones exteriores de la vertiente. **El fabricante no es responsable de la opción y de la construcción de la fundación.**  
Para una base concreta del cojín, prepare una cama llana para una capa de pie firme de la piedra machacada. El cojín concreto se debe entonces verter a un grueso de 4 pulgadas (100 mm) a 5 pulgadas (125 mm). Permita secarse a fondo por lo menos 48 horas.
- Su cobertizo debe ser firmemente anclado al bloc de concreto o cuadrados (plazas) de piedra de patio grandes concretos, ayudando a proteger contra el daño del viento fuertes.

### Cuidado & Mantenimiento

Aunque esta unidad no requiere mantenimiento, se debe tener cuidado para prolongar la vida de su caseta. Es tiempo por una vez ensamblar y configurar, sin propósito de volver a usar.

**CUBIERTA:** Mantenga el techo limpio de hojas y la nieve con mango largo y cerdas suaves escoba. Grandes cantidades de nieve en el techo pueden dañar el cobertizo y hacerlo peligroso. **“No camine sobre superficies de techo! Riesgo de caer”!**

**PAREDES:** No apoye ningún objeto contra los paneles de la pared del cobertizo.

**PUERTAS:** Mantenga las puertas cerradas para prevenir daños por el viento.

**SUJETADORES:** Verifique periódicamente su cobertizo para los tornillos, pernos, tuercas, etc, y volver a apretarlo en caso necesario.

**HUMEDAD:** Con los cambios de temperatura, la condensación se acumulará en el interior del cobertizo. Una buena ventilación ayudará en la regulación y evitar la humedad.

**SUGERENCIA:** Un sellador no corrosivo ayudaría a sellar la nave.



No guarde productos químicos inflamables, peligrosos y piscina en el edificio.  
Combustibles y corrosivos deben guardarse en recipientes herméticos un aire.  
No aplicar el fumar.



## (FR) SÉCURITÉ ET PRÉCAUTIONS

Pour votre propre sûreté, svp lisez et suivez ces instructions avant et pendant le montage.

### Avant de commencer...

1. Vérifiez vos codes de la construction et de l'habitation concernant la pose, l'emplacement, etc.
2. Choisissez un site qui laisse assez d'espace de travail autour de l'abri.
3. Déterminez la surface de l'abri et fixez les système d'ancrage aux fondations.
4. Lisez et analysez le manuel de l'abri glissé dans le paquet.
5. Suivez scrupuleusement toutes les consignes et les dimensions.
6. Suivez les étapes scrupuleusement les étapes de montage afin de monter correctement votre abri.
7. Assurez-vous que toutes les pièces sont présentes avant de débiter le montage.
8. ATTENTION : Suivez les consignes de sécurité afin d'évitez tous dommages physiques ou corporels.
9. LA SURFACE DE POSE DOIT PLANE ET DE NIVEAU : Assurez-vous que les fondations sont posées sur un sol plan et de niveau. Si le lit de sol est inégal, enlevez le gazon et autres débris et nivelez-la avec une pelle.
10. Classez l'ensemble des pièces par numéro et confrontez -les à la liste de la notice. Soyez sûr que vous avez toutes les pièces nécessaires pour le montage de votre abri.



### Safety Premier !

1. Portez toujours des gants de travail, de longues manches et des lunettes de protection des yeux pendant le montage de l'abri. Quelques morceaux de l'abri contiennent des bords agressifs et peuvent causer des dommages.
2. Soyez prudent avec les outils utilisés pour le montage de l'abri. Familiarisez-vous avec le fonctionnement de toutes machine s-outils.
3. Ne laissez pas les enfants et les animaux jouer autour de l'abri lors du montage, afin d'éviter tous risques d'accidents.
4. Si vous utilisez une échelle, assurez-vous qu'elle soit posée sur un sol plan et de niveau. Ouvrez-la entièrement et assurez-vous que les verrous de sécurité des charnières sont bien enclenchés. Ne jamais marcher sur le toit ou tout autre partie de l'abri.
5. N'essayez pas d'assembler l'abri en cas de vent fort. Les panneaux de l'abri peuvent s'envoler pendant le montage dangereux.



### Important

- Portez des lunettes de protection lors de l'utilisation de machine-outils. N'utilisez pas de machine-outils électriques dans un environnement humide afin d'éviter tous chocs électriques.
- N'utilisez pas de composant de l'abri en tant qu'échelle lors du montage de l'abri.
- L'abri doit être construit sur des fondations solides.** Une dalle de béton armé ou de dalles de béton de grandes dimensions est recommandé. S'assurer qu'elle est plane et de niveau et permettra le drainage de l'eau. La dalle devra faire 10 cm de plus que les dimensions extérieures de l'abri. Veuillez vous référer à la première page de votre manuel pour les dimensions extérieures de l'abri. **Le fabricant n'est pas responsable du choix et de la construction des fondations.**  
Le tampon de béton doit ensuite être coulé sur une épaisseur de 4 pouces (100 mm) à 5 pouces (125 mm). Laisser sécher complètement pendant au moins 48 heures.
- Votre abri doit être fermement ancré à la dalle, pour se protéger contre les risques de dommages liés aux vents forts.

### Soin et entretien

**Bien que cette unité n'exige aucun entretien, le soin devrait être pris afin de prolonger la vie de votre hangar. Il est temps pour une fois le montage et mis en place, aucun objet de réutilisation.**

**TOIT :** Le toit doit être nettoyé avec un balai mou et à long manche afin de le débarrasser des feuilles et de la neige. Une grande quantité de neige sur le toit peuvent endommager le hangar le rendant peu sûr.  
" Ne pas marcher sur des surfaces de toit ! Risque de tomber! "

**MURS :** Ne mettez aucun objet contre les panneaux de mur

**PORTES :** Assurez-vous que les portes sont fermées afin d'empêcher les risques de dommages liés aux vents forts

**PIÈCES DE FIXATION :** Examinez régulièrement vos vis, boulons, écrous, de votre abri. En cas de doute resserez-les

**HUMIDITÉ :** Avec les températures changeantes, la condensation s'accumulera à l'intérieur de l'abri. La bonne ventilation aidera à l'évacuation de l'humidité.

**CONSEIL :** Un calfeutrage non corrosif est utile afin de renforcer la durée de vie de l'abri.



**NE** pas stocker de produits chimiques inflammables, dangereux et piscine dans votre immeuble. Les combustibles et les produits chimiques doivent être stockés dans des armoires étanches et isolées. N'appliquer fumeur.





**( E N ) Note : B efore starting installation, please refer to Safety & Precautions.**

**(ES) Pozor : Antes de comenzar la instalación, consulte Seguridad y Precauciones.**

**( F R ) Note : Avant de commencer l'installation, référez-vous svp au chapitre Sécurité et Précautions.**

## (EN) Tools You Will Need

C ordless D rill - P h ilips H ead  
S crew driver - P h ilips H ead  
H ammer or R ubber mallet  
C arpenter's S q uare  
8 ' S tep L adder  
L evel - 3 ft.  
T ape M easure  
C alk G un  
W aterproof C lear S ilicon  
H and G loves  
1 3 mm S panner  
B ox S panner- 7 mm

## (ES) Equipo con herramienta Usted Necesitará

T aladro inalámbrico - cabezal Philips  
D estornillador - cabezal Philips  
M artillo o maz o de goma  
C arpintero's P laz a  
E scalera de 8 '  
N ivel - 3 ft.  
C inta mé trica  
P istola de calaf ateo  
S ilicio transparente a prueba de agua  
G uantes de la mano  
Llave 1 3 mm  
Llave de tuerca de caja- 7 mm

## (FR) Outils dont vous aurez besoin (non fournis)

Perceuse sans fil – Tête Philips  
Tournevis - Tête Philips  
M arteau ou maillet caoutch ouc  
E q uerre  
E scabeau  
N ivel - 3 ft.  
M è tre à ruban  
P istolet à cartouch e  
S ilicone neutre é tanch e  
G ants  
C è 1 3 mm  
C lé de serrage de boî te- 7 mm

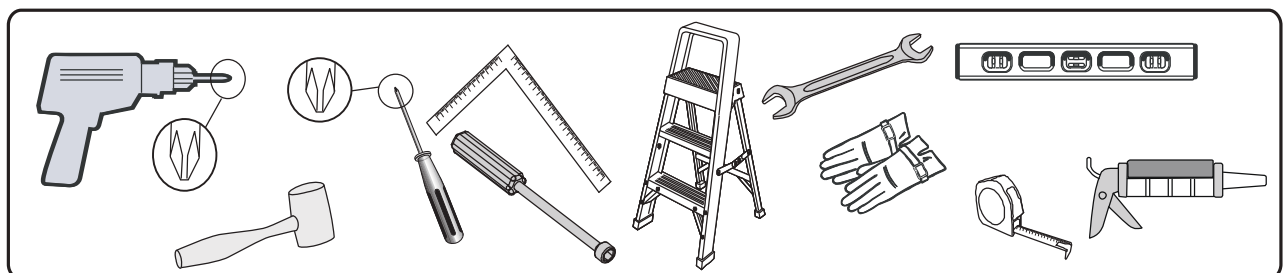

**(EN) Parts List**  
**(ES) La Lista de partes**  
**(FR) Liste des pièces**



*(EN) Check all parts prior to installation.*  
*(ES) Revisé todas las partes antes de la instalación*  
*(FR) Vérifier toutes les pièces avant d'installer.*

(EN) PROFILES (ES) PERFILES (FR) PROFILES	(EN)CODE (ES)CODE (FR)CODE	(EN)QTY (ES)QTY (FR)QTÉ	(EN) PROFILES (ES) PERFILES (FR) PROFILES	(EN)CODE (ES)CODE (FR)CODE	(EN)QTY (ES)QTY (FR)QTÉ	(EN) PROFILES (ES) PERFILES (FR) PROFILES	(EN)CODE (ES)CODE (FR)CODE	(EN)QTY (ES)QTY (FR)QTÉ
	VFB01	2		VRB04	1		CLA4	1
	VFB02	2		VRG10	1		CLG2	1
	VFA11	2		VRA36	2		WPA1↑	11
	VFA12	2		VRA40	1		WPA2↑	2
	VFG01	2		VRA37	1		WPB1↑	2
	VFA13	3		VRA41	1		FPB1	1
	VFA14	3		VRA32	2		FPB2	1
	VFA09	6		VRA33	2		FPB3	1
	VFB06	16	VRA38	2		FPB4	1	
	VBB01	1		VRA34	2		FPG1	1
	VBA04	1		VRA35	2		RPD1	1
	VBG01	1		VRA39	2		RPD3	1
	VBG02	2		VRB11	2		RPD4	1
	VBA02	1		VRB12	2		RPD5	4
	VBA03	1		VRG12	1		RPD6	1
	VBG03	1		VRG13	1		RPG1	1
	VBB04	1		VRG14	1			RPG2
	VCA03	3		VRG18	1			RPG4
	VCA04	1		VRG19	1		RPG5	1
	VCG01	2		VRG20	5			RPG6
	VCG02	1		VRG21	2	SLG1		2
	VCG03	2		VRG22	2			DLG
	VRB01	2		VRG23	10		DRG	2
	VRB03	1		VRG24	2		CLA1	1
	VRB07	1		VRG11	1		CLG1	1
	VRB08	1		VRG04	1		CLA2	4
	VRA06	3		VRG05	1		CLA3	7
	VRG03	2		CLA1	1		CLG3	2
	VRG08	1		CLG1	1			
	VRB02	2		CLA2	4			
	VRB05	2		CLA3	7			
	VRG01	2		CLG3	2			
	VRB09	2						
	VRG02	2						
	VJA01	6						
	VRG09	2						



**(EN) Parts List**  
**(ES) La Lista de partes**  
**(FR) Liste des pièces**



*(EN) Check all parts prior to installation.*  
*(ES) Revisé todas las partes antes de la instalación*  
*(FR) Vérifier toutes les pièces avant d'installer.*

<b>(EN) ROOF SUPPORT KIT</b> <b>(ES) KIT DE SOPORTE DE TECHO</b> <b>(FR) KIT DE SUPPORT DE TOIT</b>			<b>(EN) ACCESSORIES</b> <b>(ES) ACCESORIOS</b> <b>(FR) ACCESSOIRES</b>		
<b>(EN) PROFILES</b> <b>(ES) PERFILES</b> <b>(FR) PROFILES</b>	<b>(EN)CODE</b> <b>(ES)CODE</b> <b>(FR)CODE</b>	<b>(EN)QTY</b> <b>(ES)QTY</b> <b>(FR)QTÉ</b>	<b>(EN) PROFILES</b> <b>(ES) PERFILES</b> <b>(FR) PROFILES</b>	<b>(EN)CODE</b> <b>(ES)CODE</b> <b>(FR)CODE</b>	<b>(EN)QTY</b> <b>(ES)QTY</b> <b>(FR)QTÉ</b>
	VRG06	2		FDCL	2
	VRG07	2		FDCR	2
	G06D	2		FCC	4
	S3	4		FMC	9
	S8	4		FCB	4
				CBC	3
				EPS	4
				RJ	4
				LH↑	6
				RH↑	6
				L	2
				R	2
				EC2	3
				PPG	118
				PPGL	5
				PIN	118
				PINL	5
				FP	28
				F1	28
				VFA15	4
				VRG15	5
				VRG16	1
				VRG17	1
				PW	56
				S1	354
				S2	36
				S7	220
				SG1	4
				SGC1	56

(EN) Exploded View  
 (ES) El Panorama estallado  
 (FR) Vue Explosée

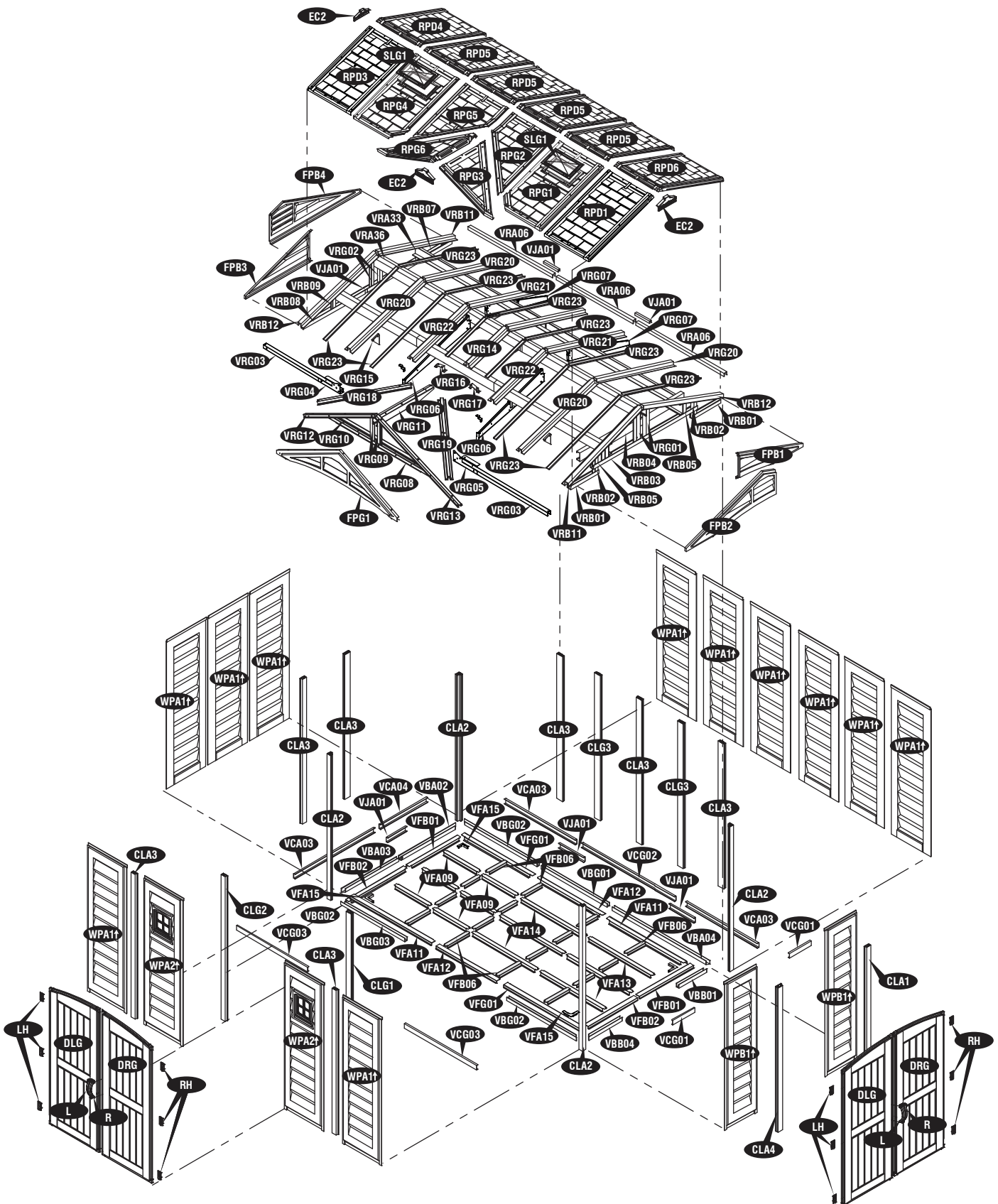

(EN) Quick Start  
 (ES) Inicio rápido  
 (FR) Démarrage rapide

- 1 → # 10-14
- 2 → # 15
- 3 → # 16-33
- 4 → # 34-49
- 5 → # 50-69
- 6 → # 65-70
- 7 → # 71-74

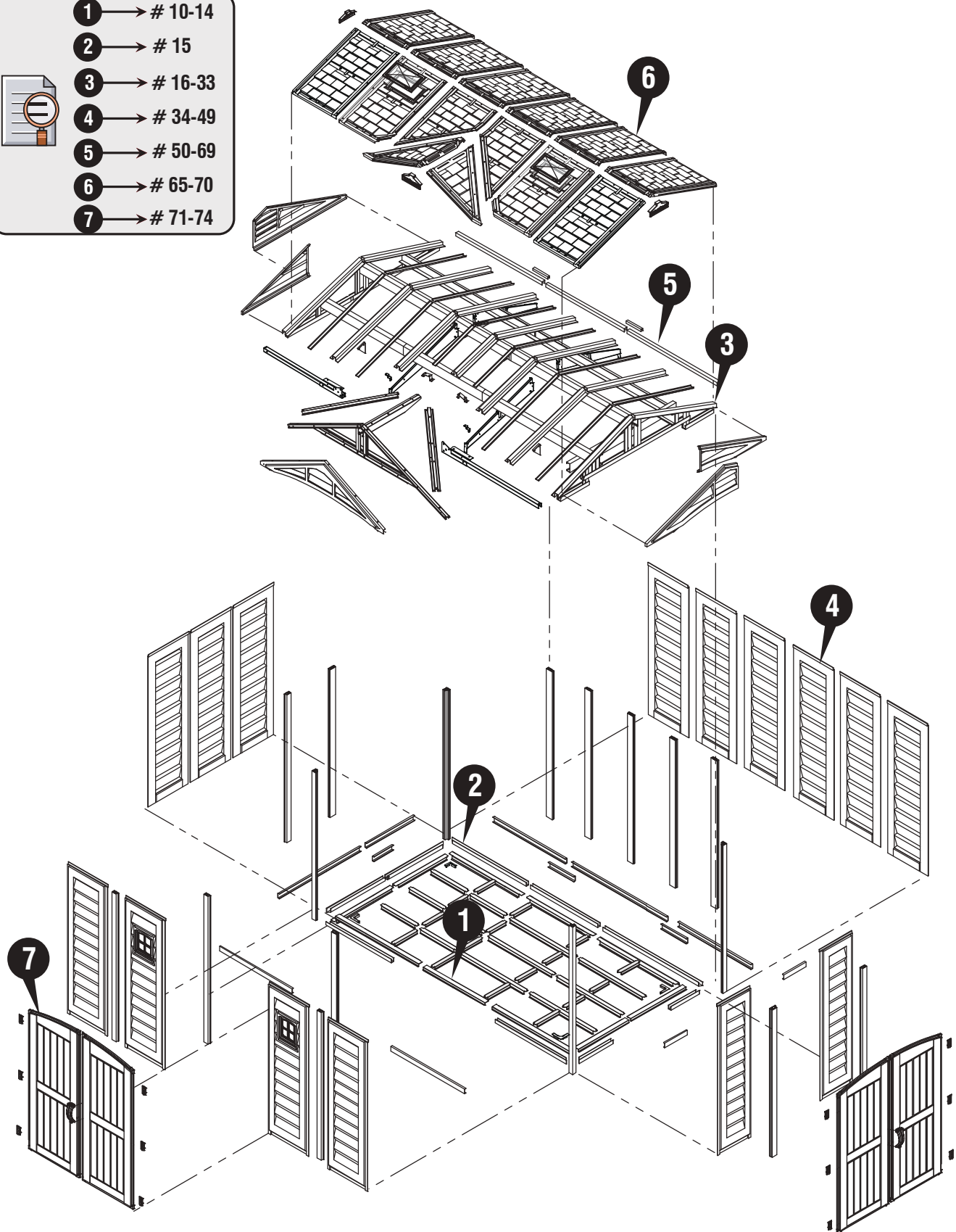



**1**

**(EN) Foundation**  
**(ES) La base**  
**(FR) Fondation**



- (EN)** 1 . It is important that these instructions are followed step by step.  
 2 . All parts are clearly marked and care should be taken to use the correct one.  
 3 . Don't install under windy conditions.  
 4 . If you are building the shed against a wall, build it 2 .5 ft. away then slide it in.  
 ( Only for Duramax foundation & Wooden foundation)

**(EN) Parts needed**  
**(ES) Las partes necesarias**  
**(FR) Pièces nécessaires**

(EN)CODE (ES)CODE (FR)CODE	(EN)QTY (ES)QTY (FR)QTY
VFB01	2
VFB02	2
VFA11	2
VFA12	2
VFG01	2
VFA13	3
VFA14	3
VFB06	16
VFA09	6
VFA15	4
S1	79

- (ES)** 1 . es importante que estas instrucciones se sigan paso a paso.  
 2 . Todas las piezas son marcadas claramente y cuidan debe ser tomado para usar el correcto uno.  
 3 . No instale las condiciones bajo de mucho viento.  
 4 . Si usted está construyendo la cubierta contra una pared, construirlo 2 .5 pies de distancia y deslízala hacia dentro. (esto sólo es aplicable para la Fundación de Duramax Fundación de madera).

- (FR)** 1 . Il est important que ces instructions soient suivies pas à pas.  
 2 . Toutes les pièces sont clairement identifiées et il faut veiller à utiliser la bonne.  
 3 . Ne pas installer sous conditions de vent.  
 4 . Si vous construisez le hangar contre un mur, le construire à un écart de 2,5 pi, puis le glisser. ( ceci n'est applicable pour la Fondation Duramax Fondation en bois ) .



**(EN) Levelled Solid Floor Surface Required**  
**(ES) Nivelado piso sólido superficie requerida**  
**(FR) Surface de plancher solide nivelée requise**

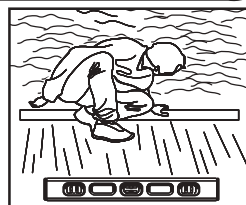

- (EN)** DuraMax must be installed on a level wooden platform or a level concrete foundation, that has an outside dimension of 98 1/4" x 191 5/8" (2497mm x 4867mm).  
**(ES)** DuraMax debe instalarse en una plataforma de madera nivelada o una base de hormigón nivelada, que tenga una dimensión exterior de 98 1/4" x 191 5/8" (2497mm x 4867mm).  
**(FR)** DuraMax doit être installé sur une plate-forme en bois de niveau ou une fondation en béton de niveau, qui a une dimension extérieure de 98 1/4" x 191 5/8" (2497mm x 4867mm).

- (EN)** Set the Torque limit of your Screw drill to #3 or #4 to ensure the screws do not strip the Metal reinforcements.  
**(ES)** Establecer el límite de par de su taladro tornillo de # 3 y # 4 para asegurar los tornillos no tira los refuerzos metálicos.  
**(FR)** Réglez la limite de couple de votre perceuse Vis à n° 3 ou n° 4 pour s'assurer que les vis ne suppriment pas les renforts métalliques.



- (EN) Note :** For plywood cut size, refer to page 7 6.  
**(ES) Pozor :** Para contrachapado cortado tamaño, consulte la página 7 6.  
**(FR) Note :** Pour le contreplaqué dimensions, reportez-vous à la page 7 6.

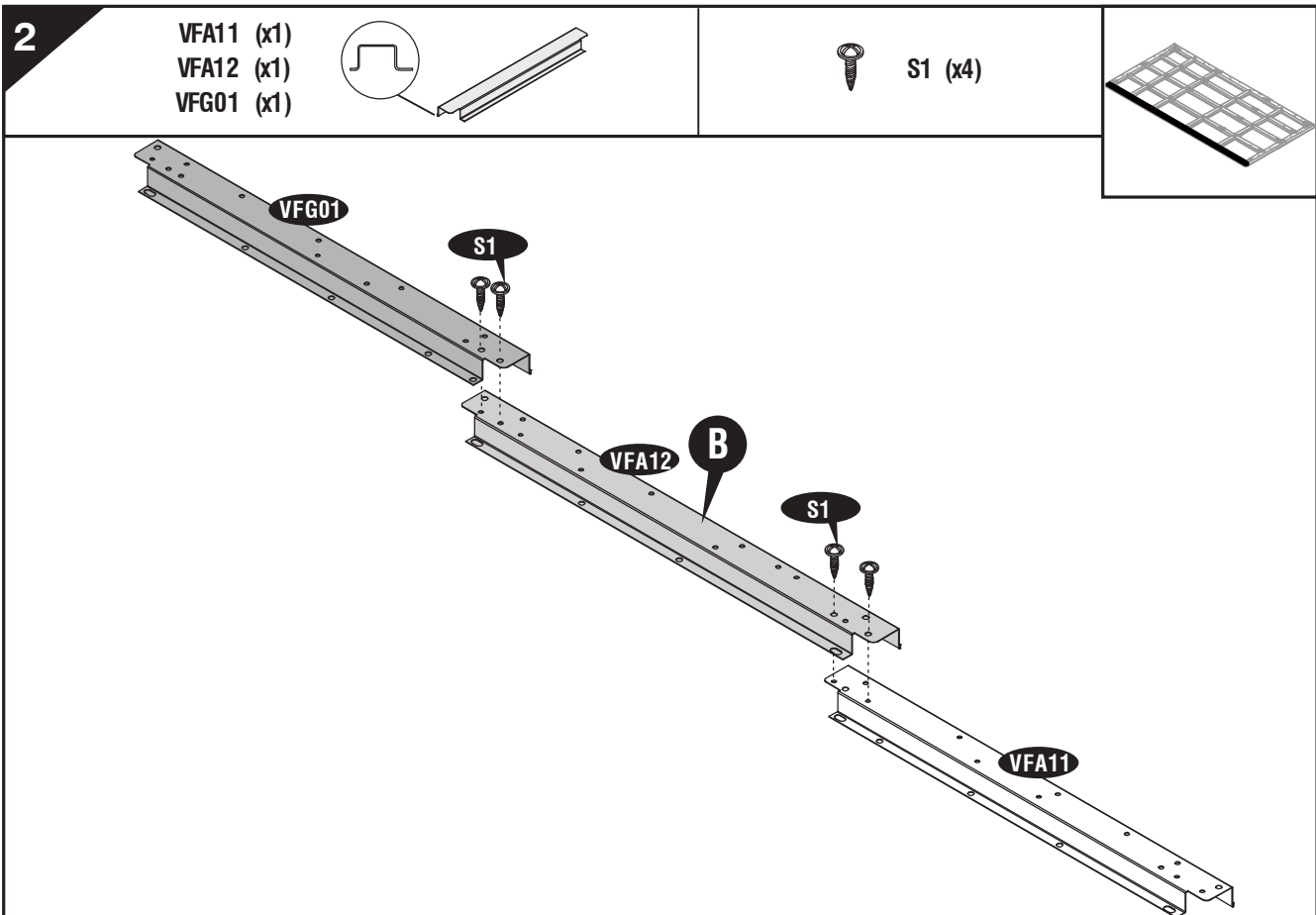
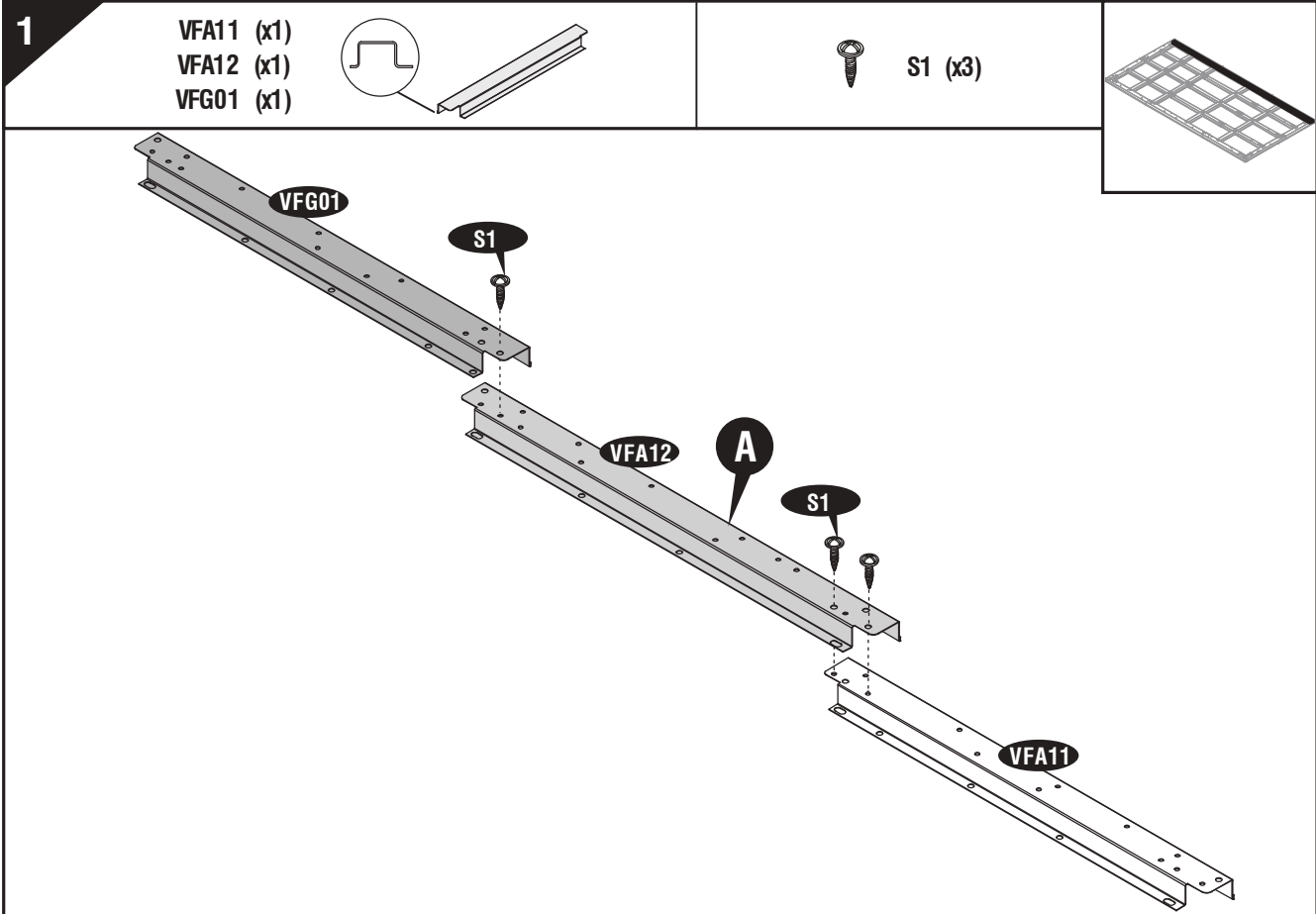

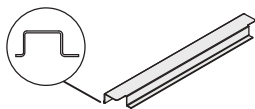
**3**VFB01 (x2)  
VFB02 (x2)

S1 (x4)

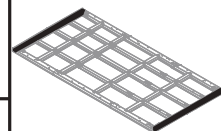

( E N ) Note : M ak e 2 Sets.  
 ( E S ) Pozor : Hace 2 conjuntos.  
 ( F R ) Note : F aire 2 ensembles.

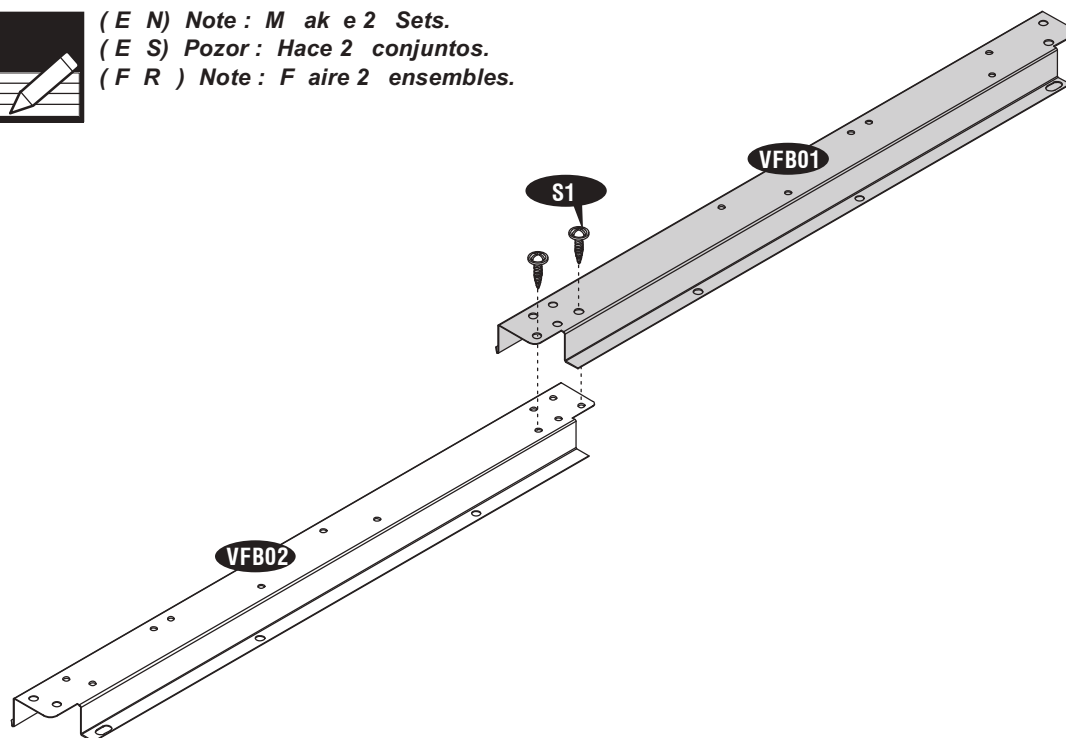
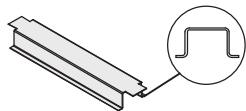
**4**VFA09 (x6)  
VFA13 (x3)  
VFA14 (x3)

S1 (x18)

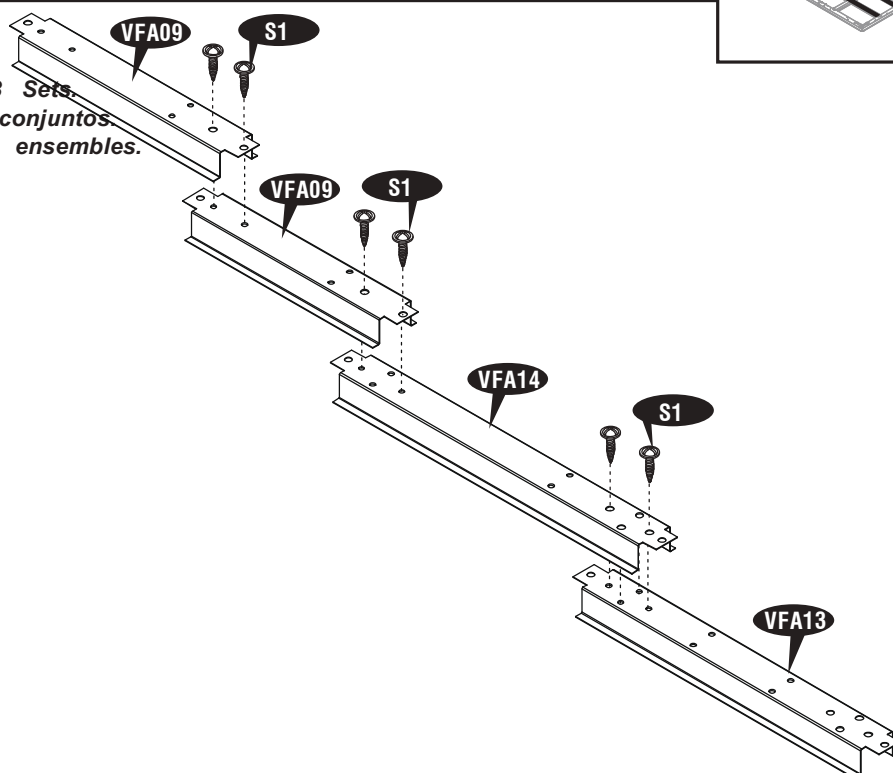

( E N ) Note : M ak e 3 Sets.  
 ( E S ) Pozor : Hace 3 conjuntos.  
 ( F R ) Note : F aire 3 ensembles.

**12**

(EN) IMPORTANT: USE HAND GLOVES TO PREVENT INJURY.  
 (FR) IMPORTANT: UTILISER LES GANTS POUR PREVENIR LES ACCIDENTS.

(ES) IMPORTANTE: GUANTES DE MANO DE USO PARA PREVENIR LA HERIDA.

5

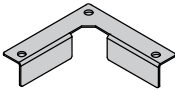

VFA15 (x2)



S1 (x6)

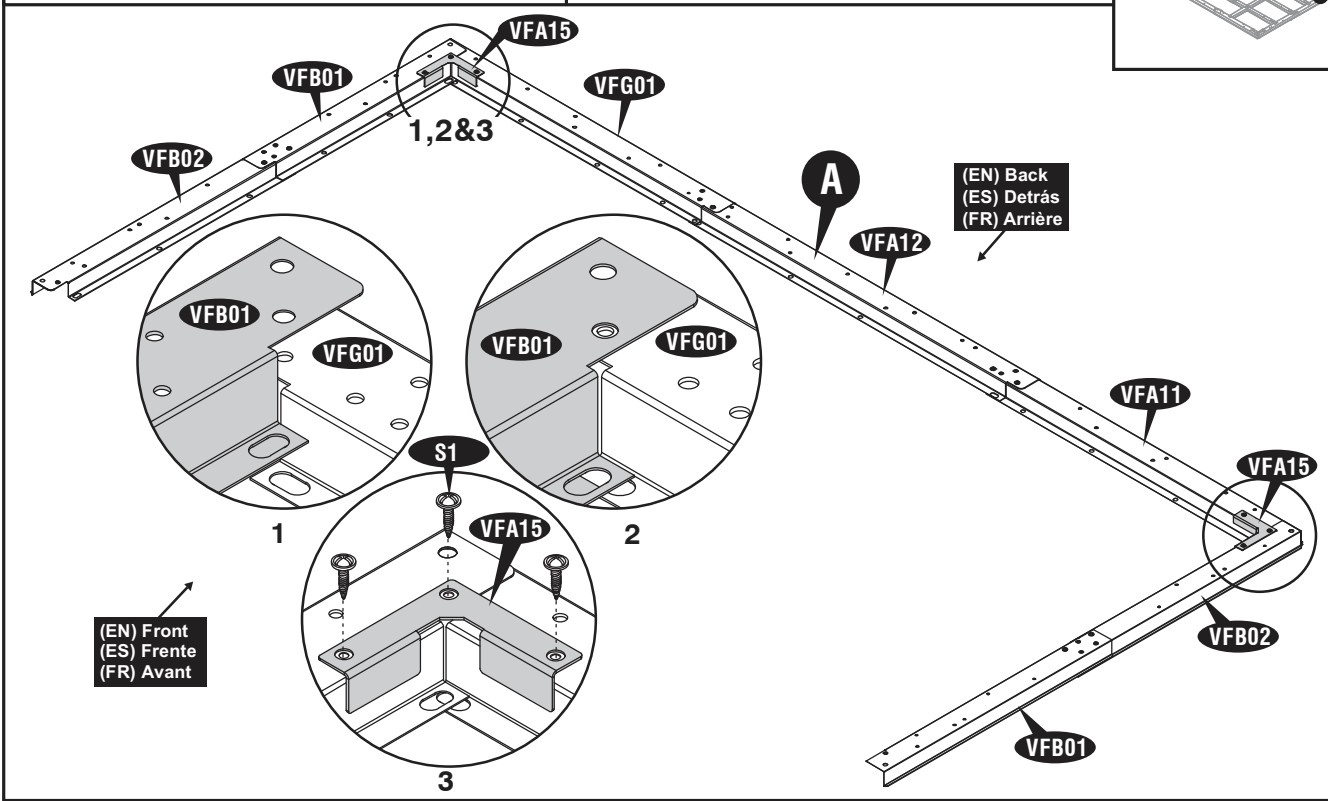
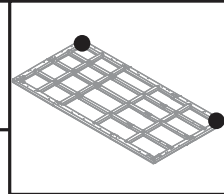

6

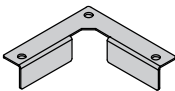

VFA15 (x2)



S1 (x6)

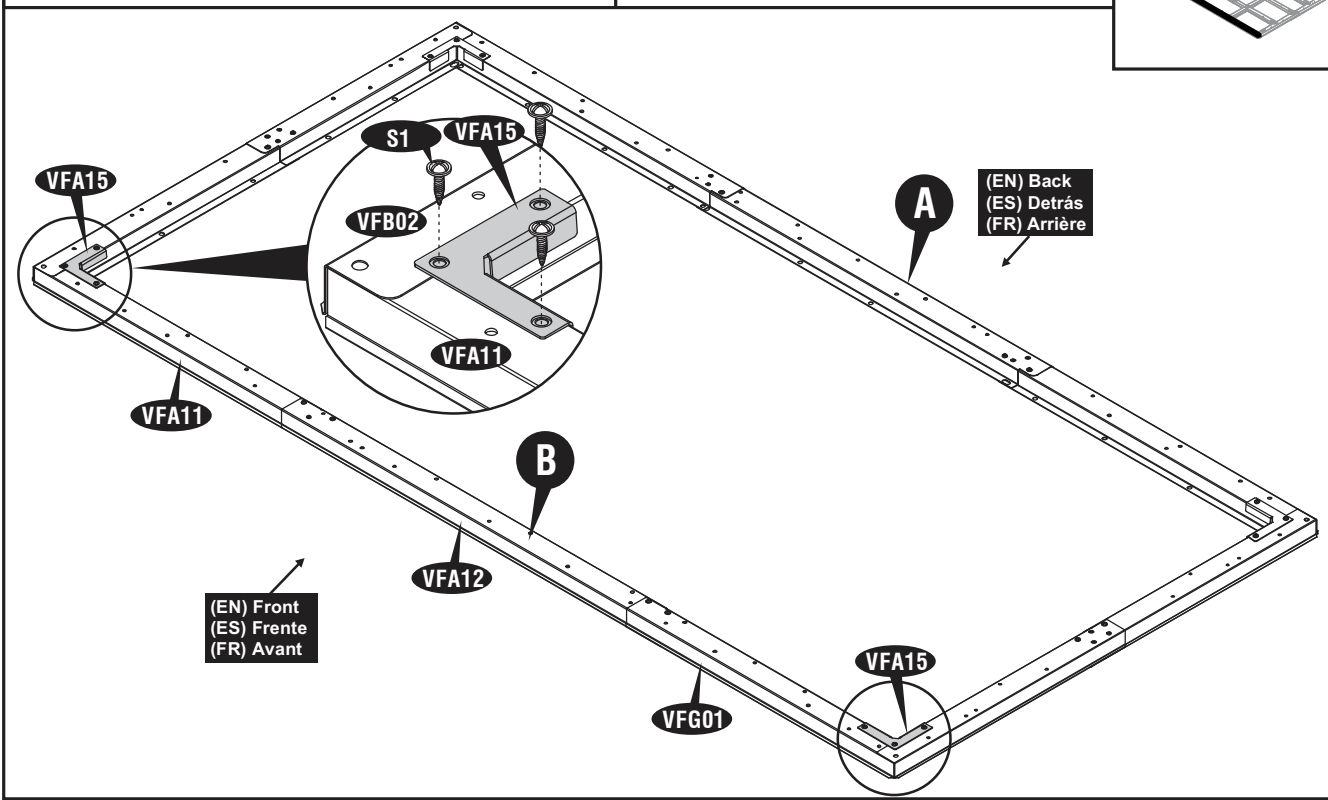
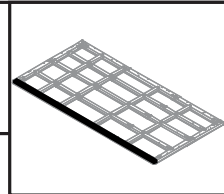

13

(EN) IMPORTANT: USE HAND GLOVES TO PREVENT INJURY.  
 (FR) IMPORTANT: UTILISER LES GANTS POUR PREVENIR LES ACCIDENTS.  
 (ES) IMPORTANTE: GUANTES DE MANO DE USO PARA PREVENIR LA HERIDA.

7

S1 (x6)

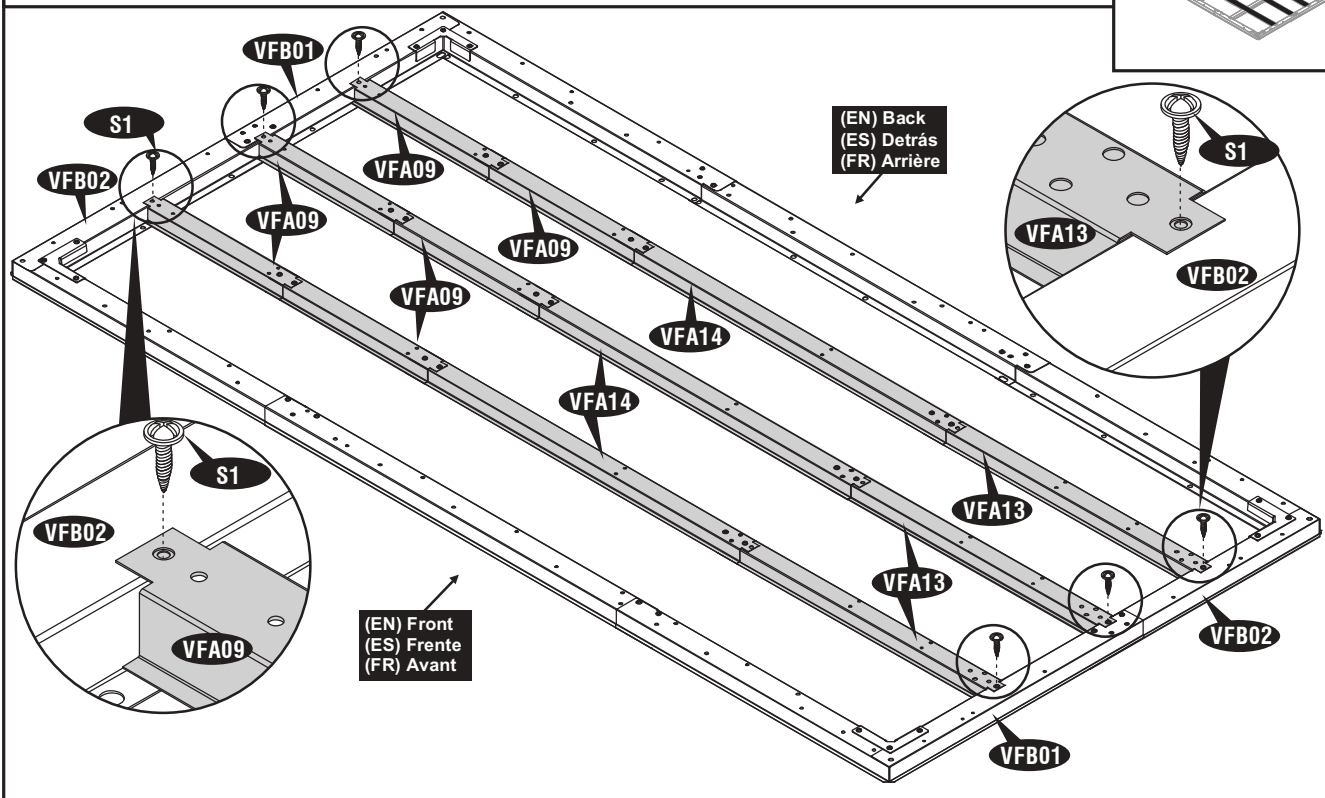
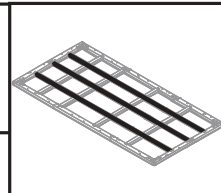

8

VFB06 (x16)

S1 (x32)

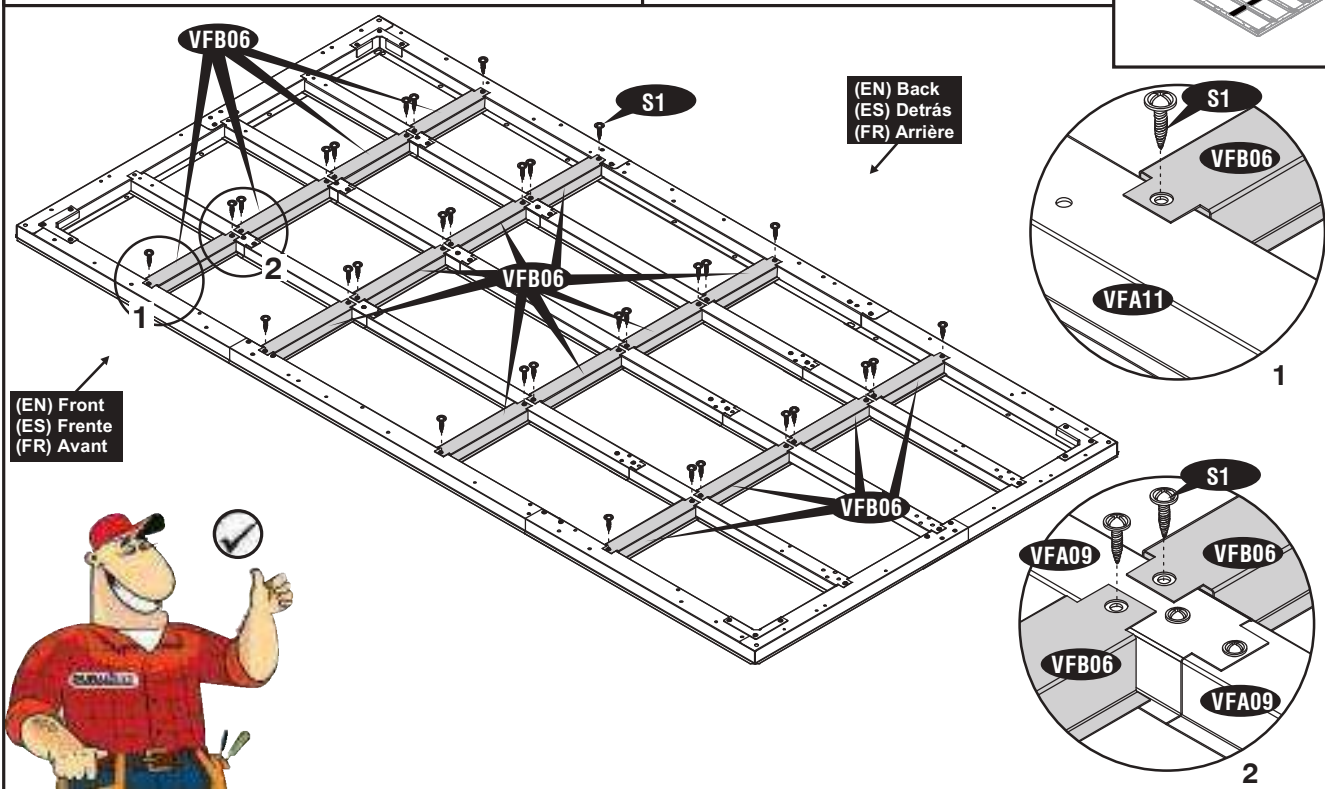
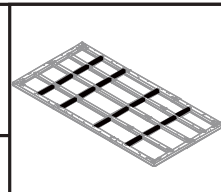

14

(EN) IMPORTANT: USE HAND GLOVES TO PREVENT INJURY.  
(FR) IMPORTANT: UTILISER LES GANTS POUR PREVENIR LES ACCIDENTS.

(ES) IMPORTANTE: GUANTES DE MANO DE USO PARA PREVENIR LA HERIDA.





2

(EN) Base Frame  
(ES) Armazón de la base  
(FR) Profiles de base



(EN) Parts needed  
(ES) Las partes necesitaron  
(FR) Pièces nécessaires

(EN)CODE (ES)CODE (FR)CODE	(EN)QTY (ES)QTY (FR)QTÉ	(EN)CODE (ES)CODE (FR)CODE	(EN)QTY (ES)QTY (FR)QTÉ
VBA02	1	VBA04	1
VBA03	1	VBB01	1
VBG01	1	VBB04	1
VBG02	2	S1	37
VBG03	1		

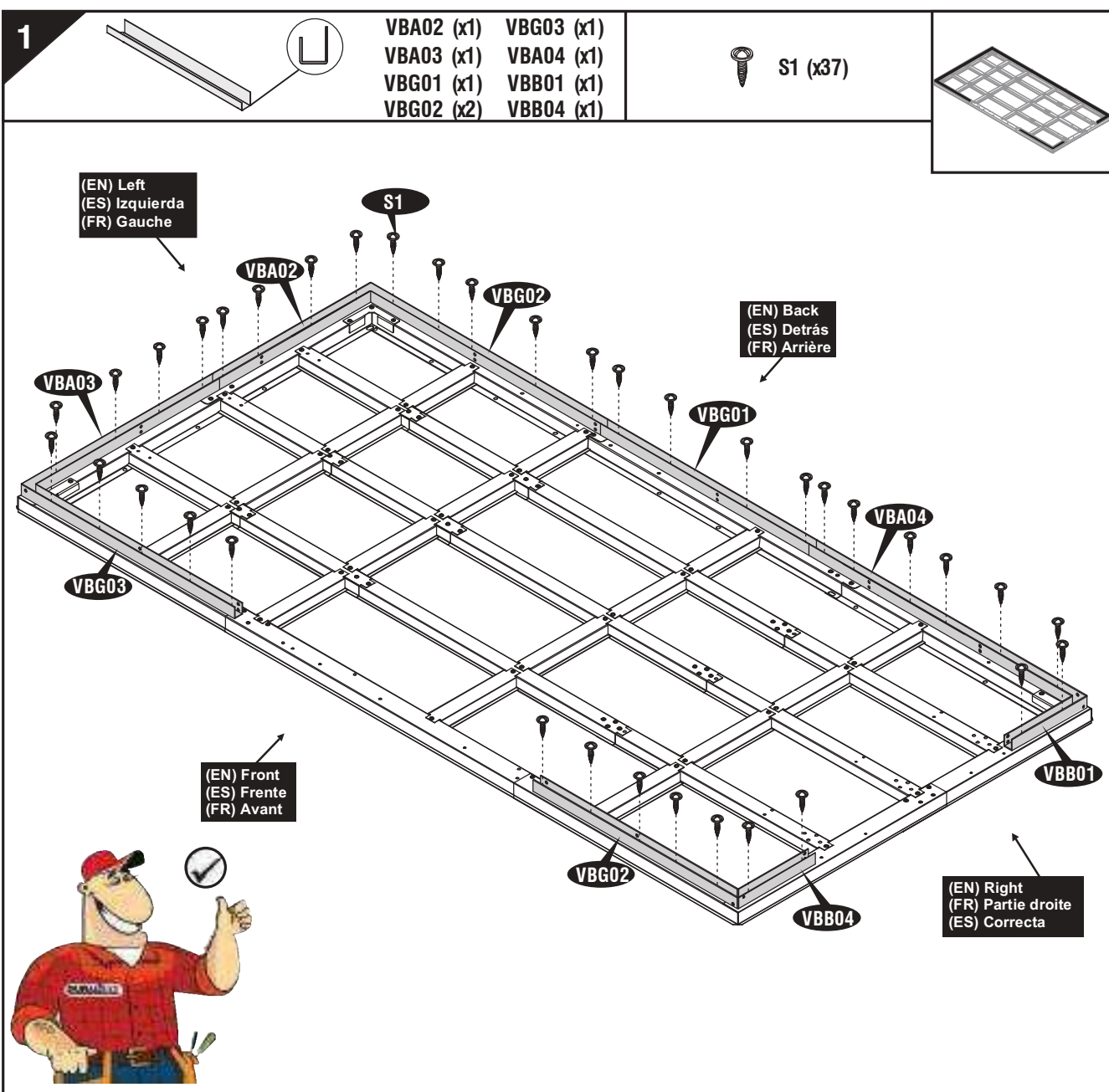



**3**

**(EN) Structure & Fascia Panel Pre Assembly**  
**(ES) Estructura y panel de fascia pre ensamblaje**  
**(FR) Pré-assemblage des panneaux de structure et de façade**



**(EN) : All parts are clearly marked and care should be taken to use the correct one.**

**(ES) : Todo pone piezas son marcados claramente y cuidan debe ser tomado para usar el corrige uno.**

**(FR) : Toutes les pièces sont clairement identifiées et il faut veiller à utiliser la bonne.**

**(EN) Parts needed**  
**(ES) Las partes necesitaron**  
**(FR) Pièces nécessaires**

(EN)CODE (ES)CODE (FR)CODE	(EN)QTY (ES)QTY (FR)QTÉ	(EN)CODE (ES)CODE (FR)CODE	(EN)QTY (ES)QTY (FR)QTÉ	(EN)CODE (ES)CODE (FR)CODE	(EN)QTY (ES)QTY (FR)QTÉ
VCA03	3	VRA37	1	G06D	2
VJA01	6	VRA40	1	FPB1	1
VCA04	1	VRA41	1	FPB2	1
VCG02	1	VRA32	2	FPB3	1
VRB01	2	VRA34	2	FPB4	1
VRB07	1	VRA38	2	RJ	4
VRB08	1	VRA39	2	FP	18
VRB09	2	VRA33	2	S1	68
VRG02	2	VRA35	2	S3	4
VRB03	1	VRG15	5	S7	102
VRB02	2	VRG08	1	S8	4
VRB04	1	VRG09	2		
VRB05	2	VRG10	1		
VRG01	2	VRG11	1		
VRA06	3	VRG12	1		
VRG03	2	VRG13	1		
VRG04	1	VRG06	2		
VRG05	1	VRG07	2		
VRA36	2				

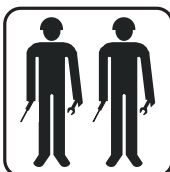

**(EN) Two people needed.**  
**(ES) Dos personas que se necesitan.**  
**(FR) Deux personnes nécessaires.**

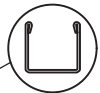
**1**VCA03 (x1)  
VCG02 (x1)

VJA01 (x1)

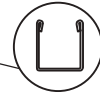

S1 (x4)

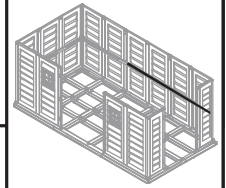
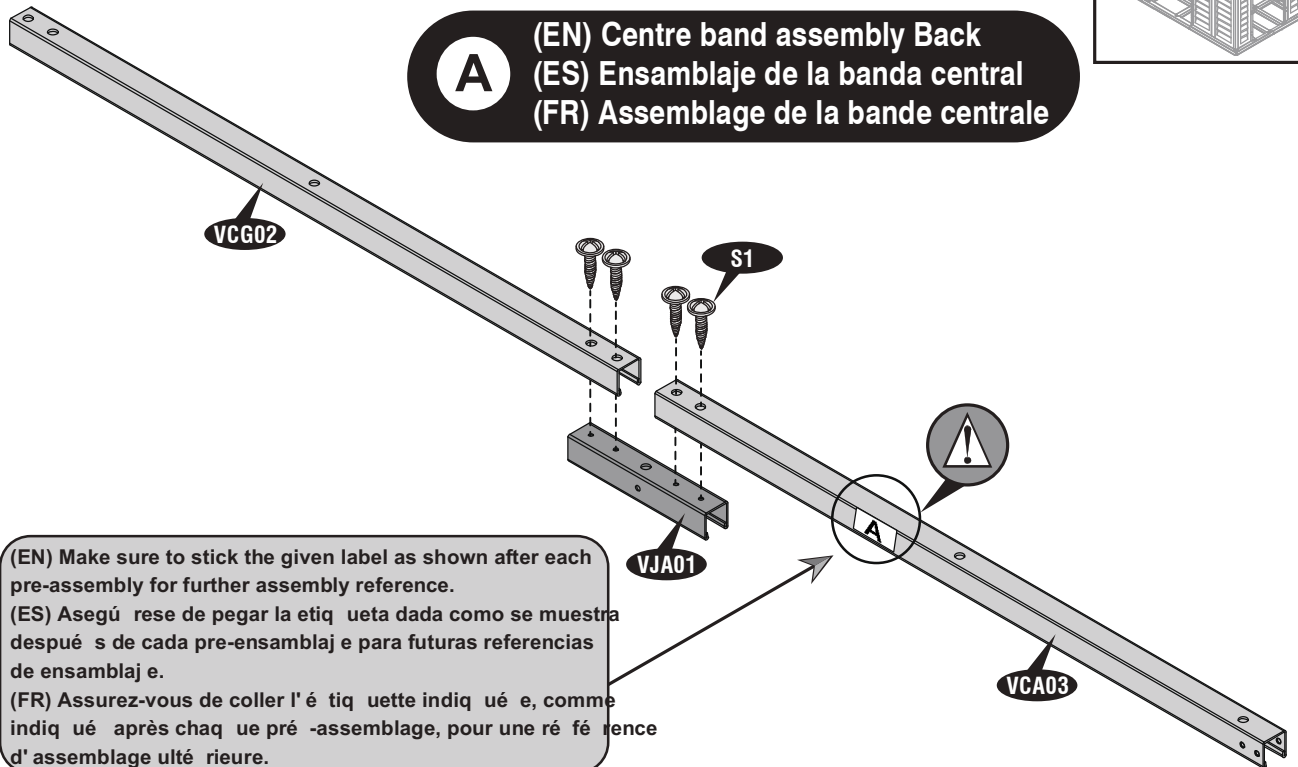
**A****(EN) Centre band assembly Back**  
**(ES) Ensamblaje de la banda central**  
**(FR) Assemblage de la bande centrale****2**

VCA03 (x1)



VJA01 (x1)

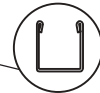

S1 (x2)

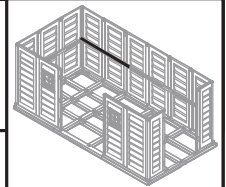
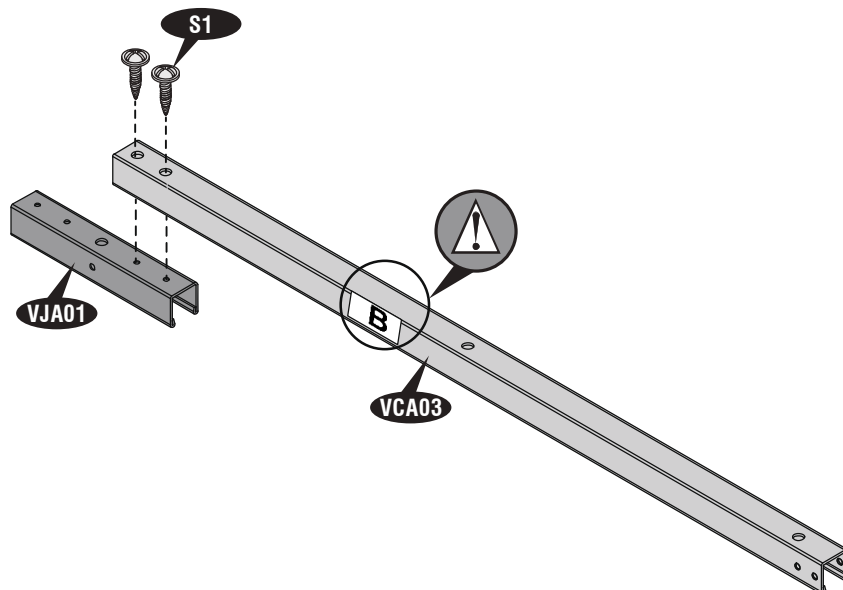
**B****(EN) Centre band assembly Back**  
**(ES) Ensamblaje de la banda central**  
**(FR) Assemblage de la bande centrale**

3

VCA03 (x1)  
VCA04 (x1)

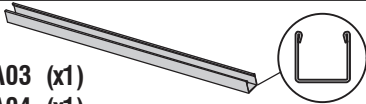

VJA01 (x1)

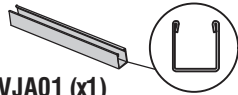

S1 (x4)

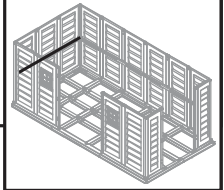

**C**

(EN) Centre band assembly Left side  
(ES) Ensamblaje de la banda central del lado izquierdo  
(FR) Assemblage de la bande centrale gauche

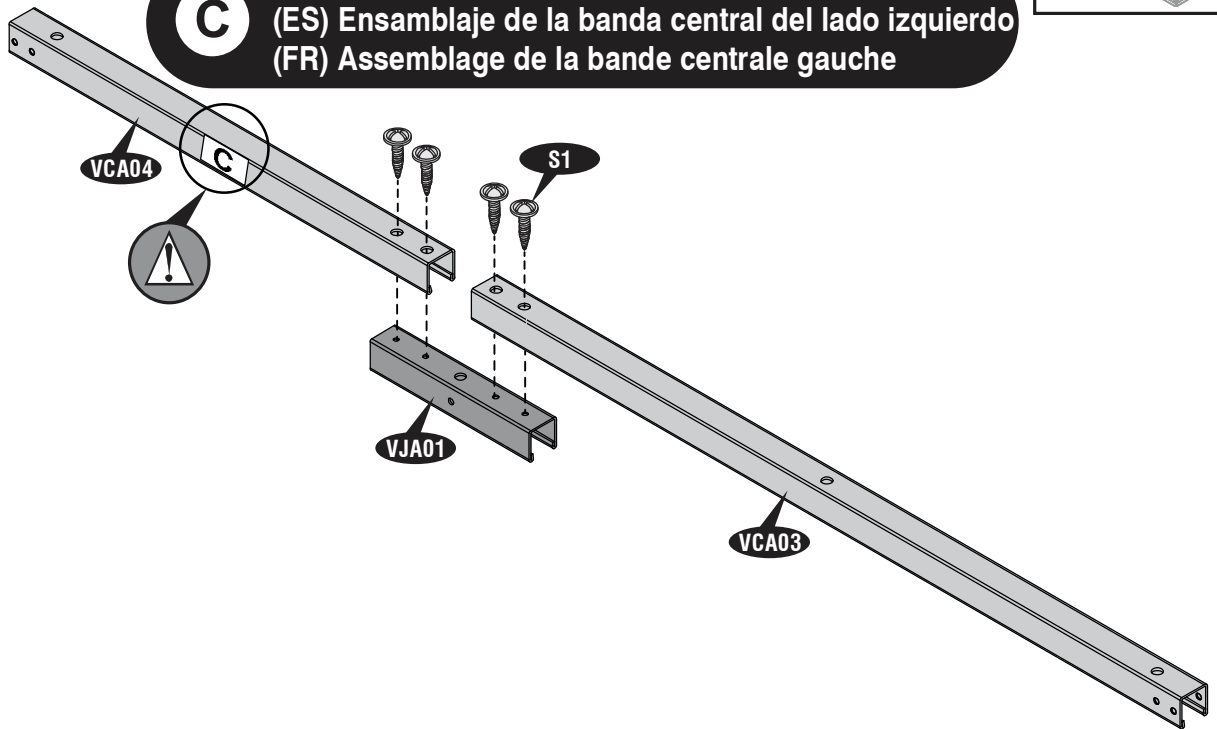

**D**

(EN) Left Roof Structure Assembly  
(ES) Montaje de la estructura del techo izquierdo  
(FR) Assemblage de la structure de toit gauche

4

VRB07 (x1)  
VRB08 (x1)

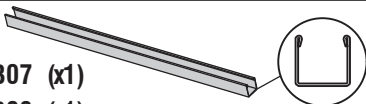

VJA01 (x1)

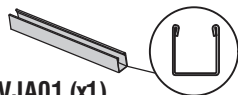

S1 (x4)

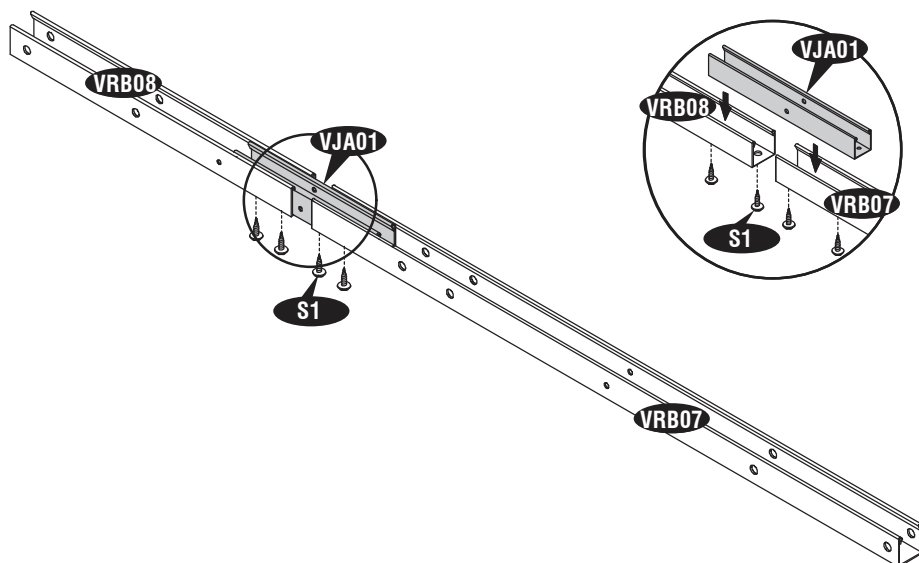
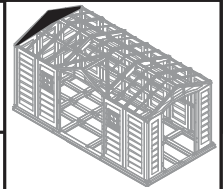

18

(EN) IMPORTANT: USE HAND GLOVES TO PREVENT INJURY.  
(FR) IMPORTANT: UTILISER LES GANTS POUR PREVENIR LES ACCIDENTS.

(ES) IMPORTANTE: GUANTES DE MANO DE USO PARA PREVENIR LA HERIDA.

5

VRB09 (x2)

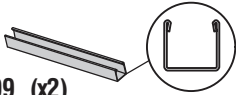

VRG02 (x2)

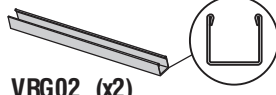

S1 (x8)

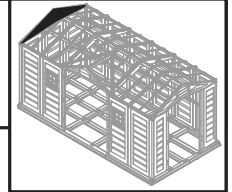

( E N ) M a k e s u r e t h e s e h o l e s a r e u p .  
( ES ) A s e g ú r e s e d e q u e l o s o r i f i c i o s e s t é n h a c i a a r r i b a .  
( F R ) A s s u r e z - v o u s q u e c e s t r o u s s o i e n t p o s i t i o n n é s v e r s l e h a u t .

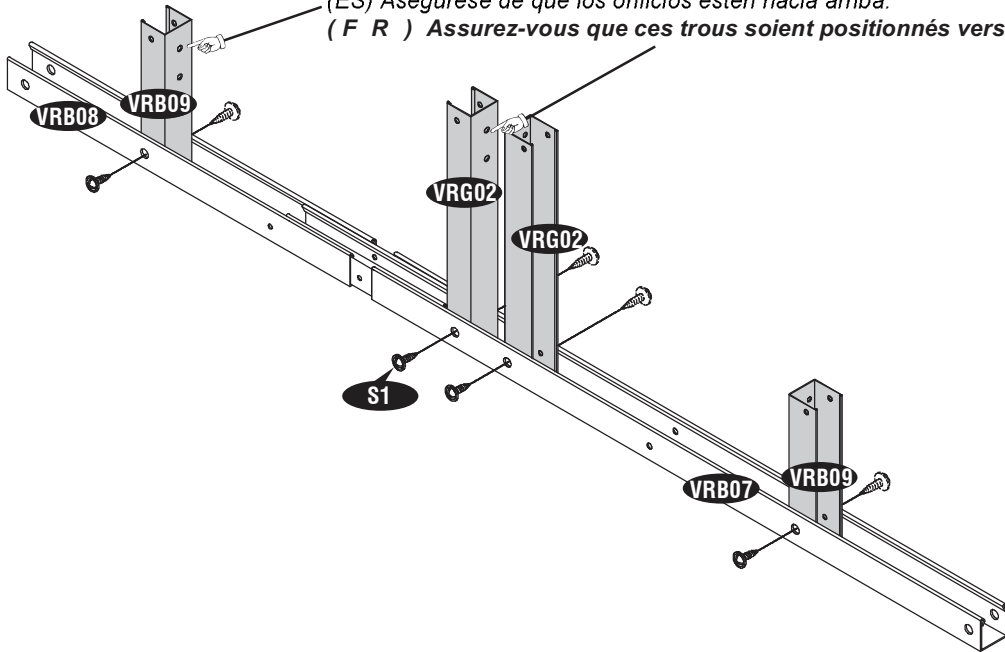

6

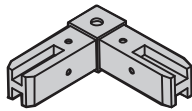

RJ (x2)

S1 (x2)

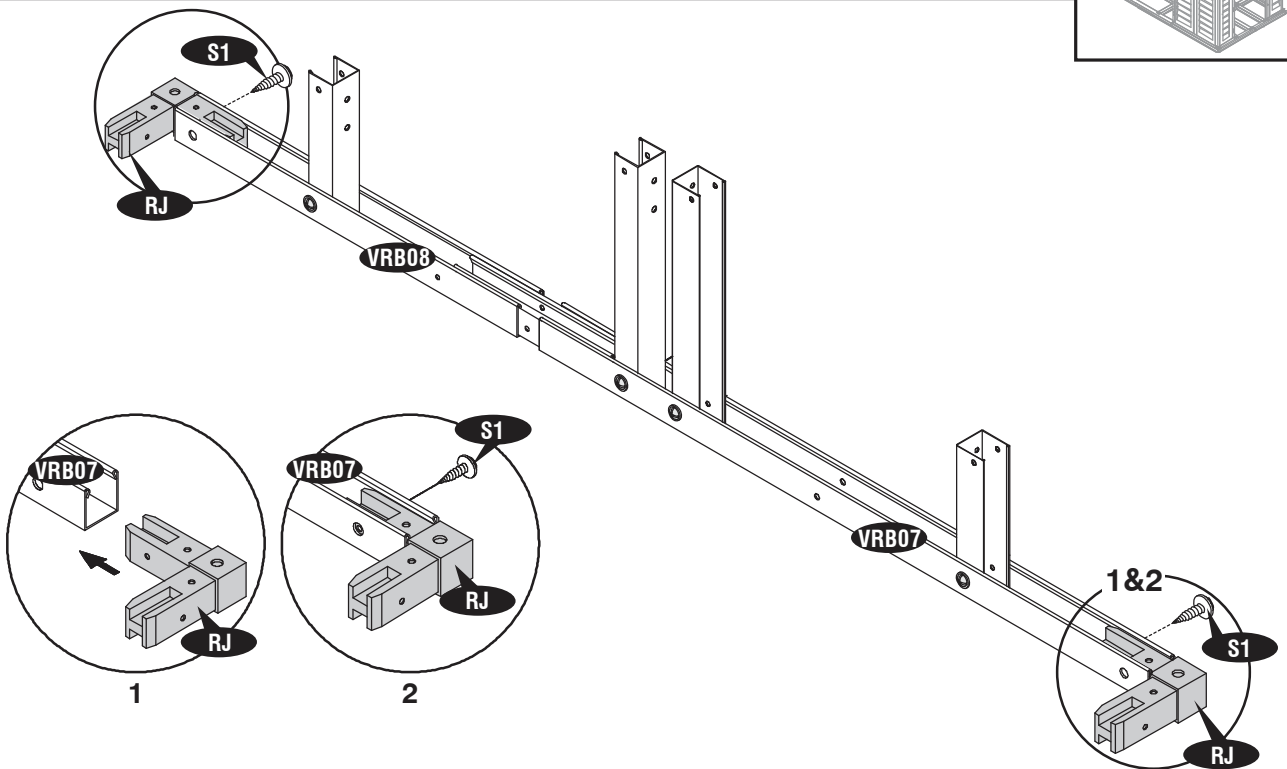
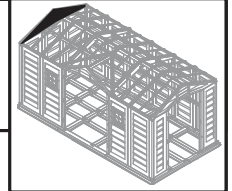

**7**

FPB3 (x1)      FP (x3)

( E N ) Note : Use the same colour Plugs ( F P )  
 (ES) Pozor : U tilice el mismo color ( F P ).  
 ( F R ) Note : Utilisez la même couleur ( F P )

**8**

FPB4 (x1)      FP (x7)

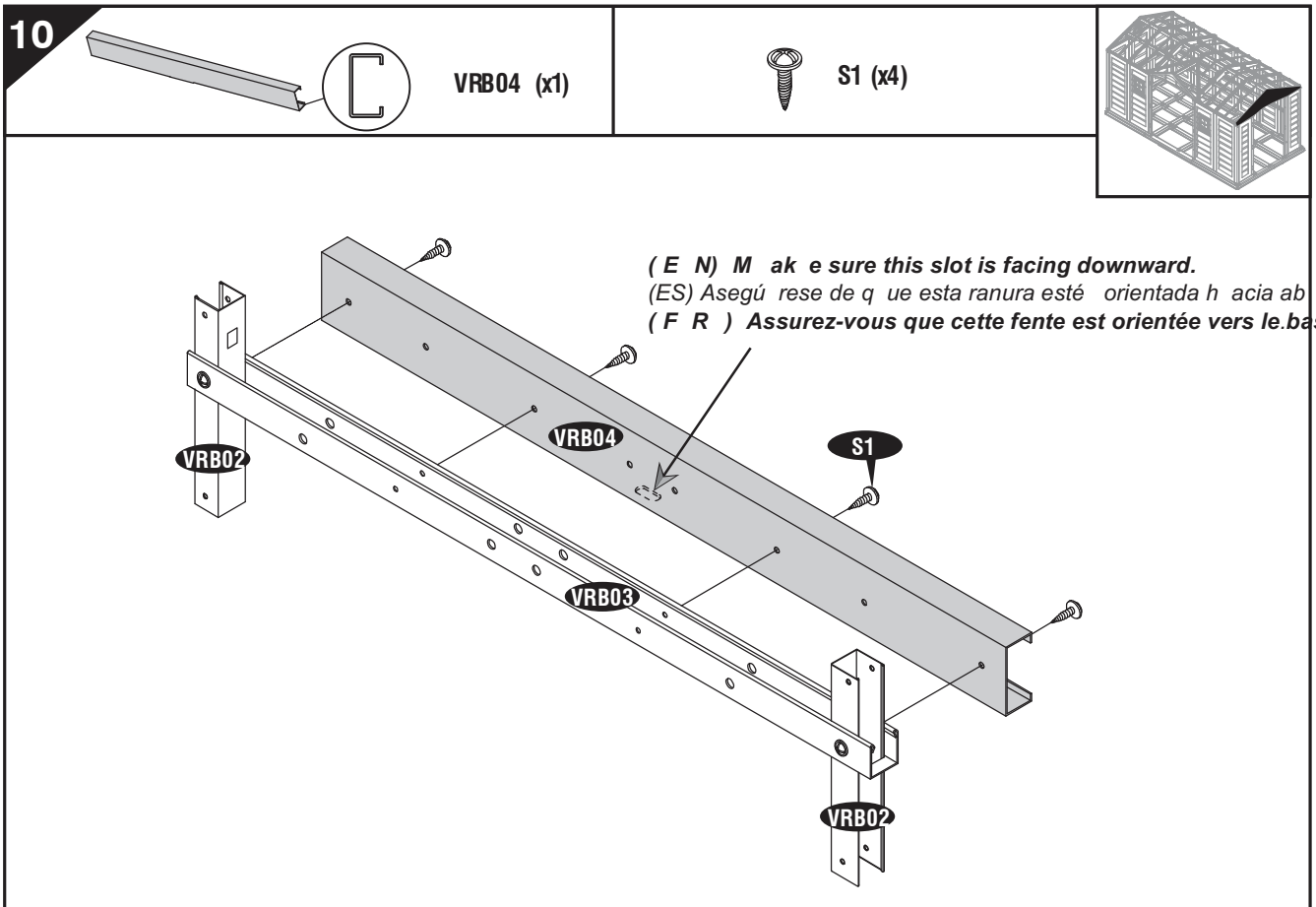
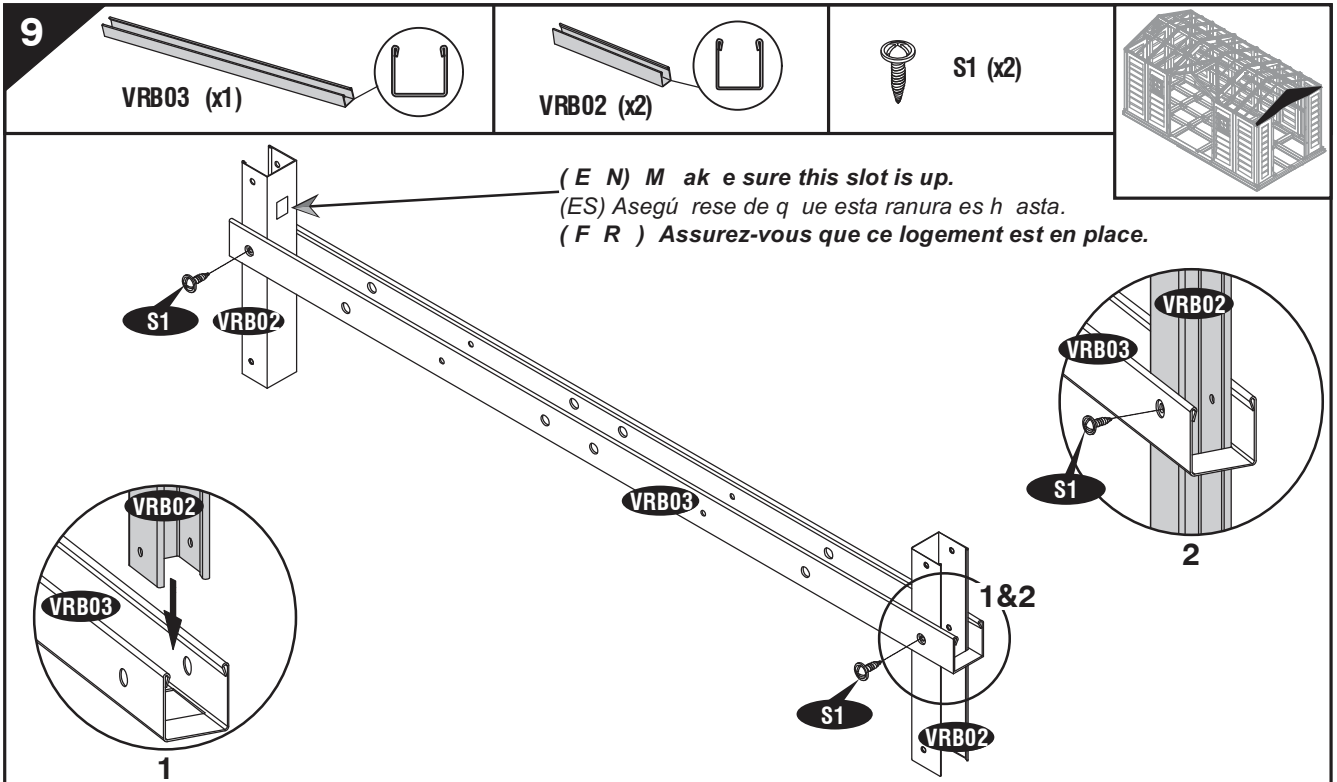
**E****(EN) Right Roof Structure Assembly****(ES) Montaje de la estructura del techo derecho****(FR) Assemblage de la structure de toit droite****21**

(EN) IMPORTANT: USE HAND GLOVES TO PREVENT INJURY.  
 (FR) IMPORTANT: UTILISER LES GANTS POUR PREVENIR LES ACCIDENTS.

(ES) IMPORTANTE: GUANTES DE MANO DE USO PARA PREVENIR LA HERIDA.

11

VRB05 (x2)

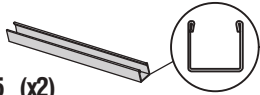

VRG01 (x2)

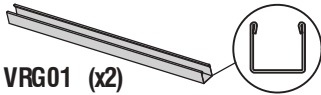

S1 (x8)

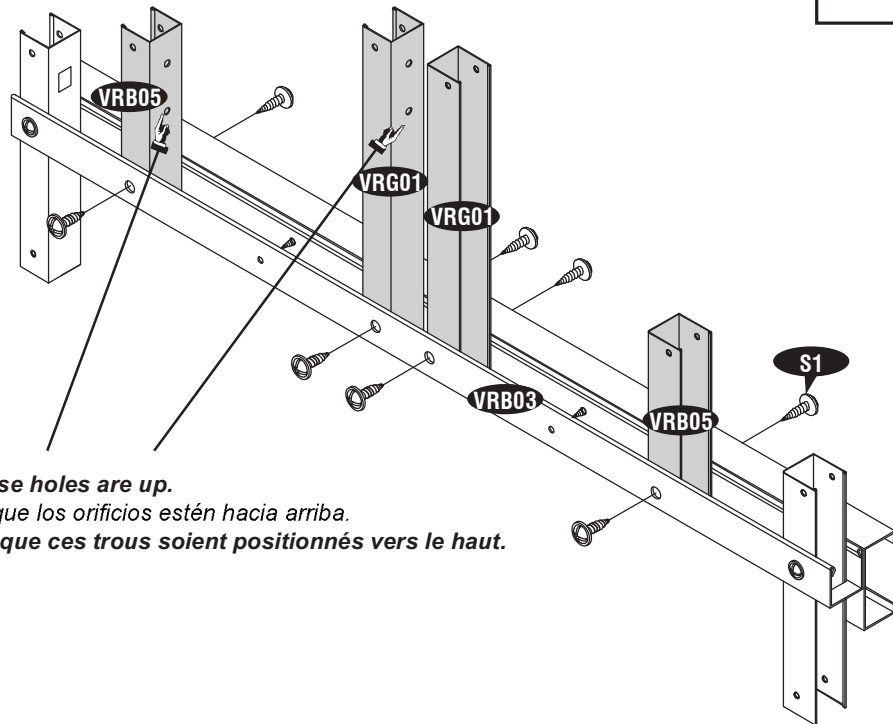
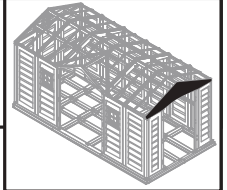

(EN) Make sure these holes are up.

(ES) Asegúrese de que los orificios estén hacia arriba.

(FR) Assurez-vous que ces trous soient positionnés vers le haut.

12

VRB01 (x2)

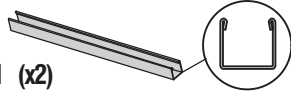

RJ (x2)

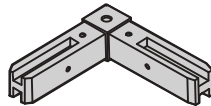

S1 (x2)

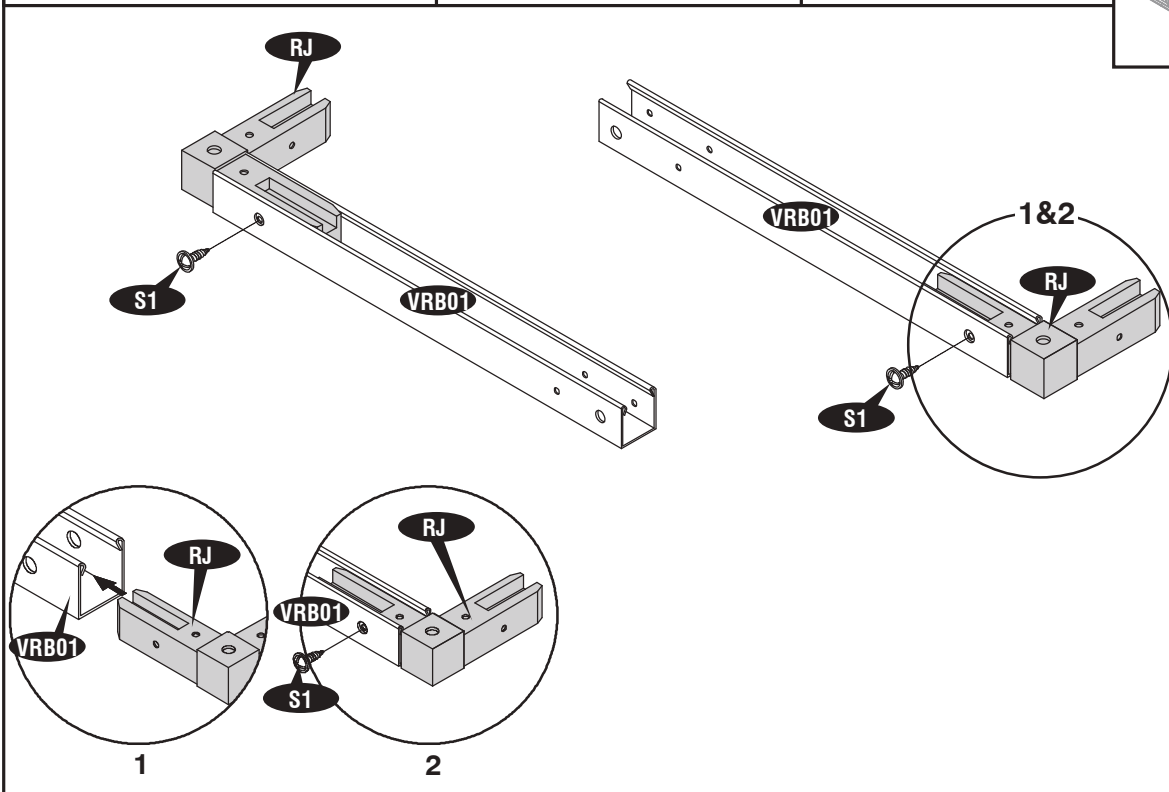
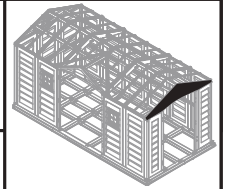

22

(EN) IMPORTANT: USE HAND GLOVES TO PREVENT INJURY.  
(FR) IMPORTANT: UTILISER LES GANTS POUR PREVENIR LES ACCIDENTS.

(ES) IMPORTANTE: GUANTES DE MANO DE USO PARA PREVENIR LA HERIDA.



13



S1 (x2)

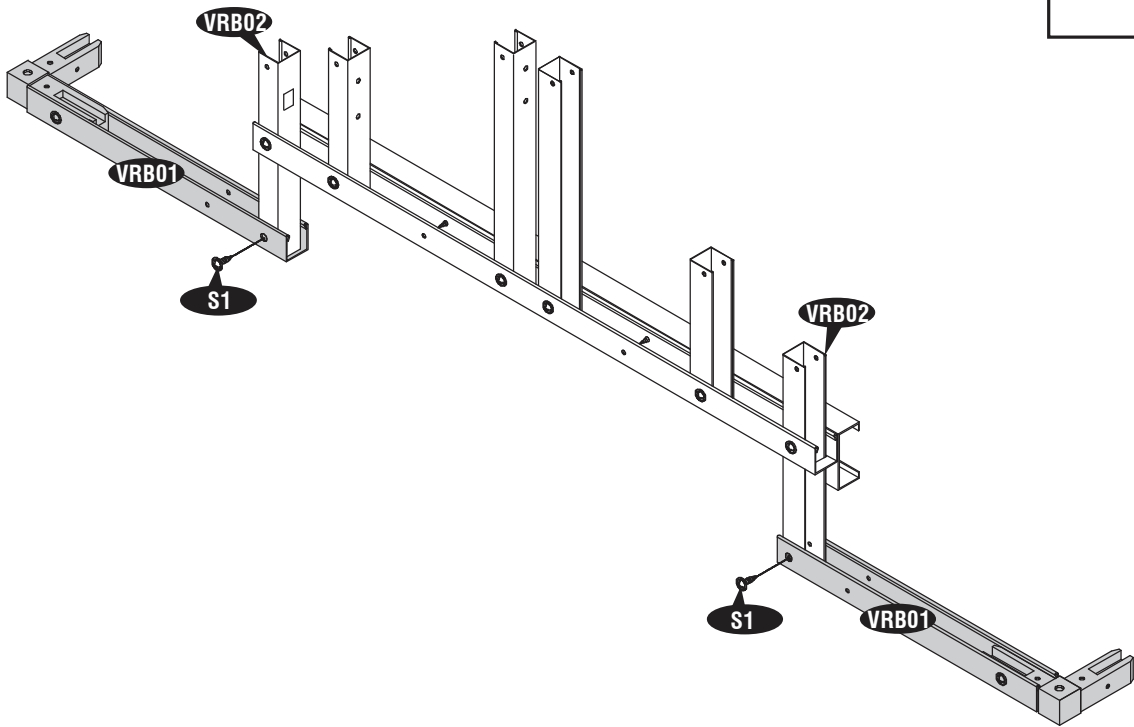
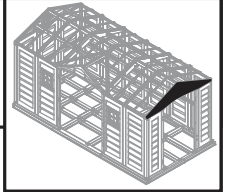

14

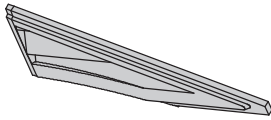

FPB1 (x1)



FP (x2)

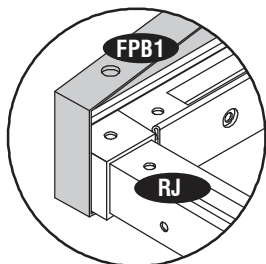
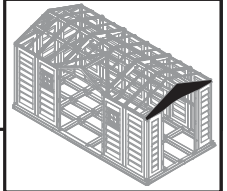

1



( E N ) Note : Use the same colour Plugs ( F P ) .  
 ( ES ) Pozor : U tilice el mismo color ( F P ) .  
 ( F R ) Note : Utilisez la mê me couleur ( F P ) .

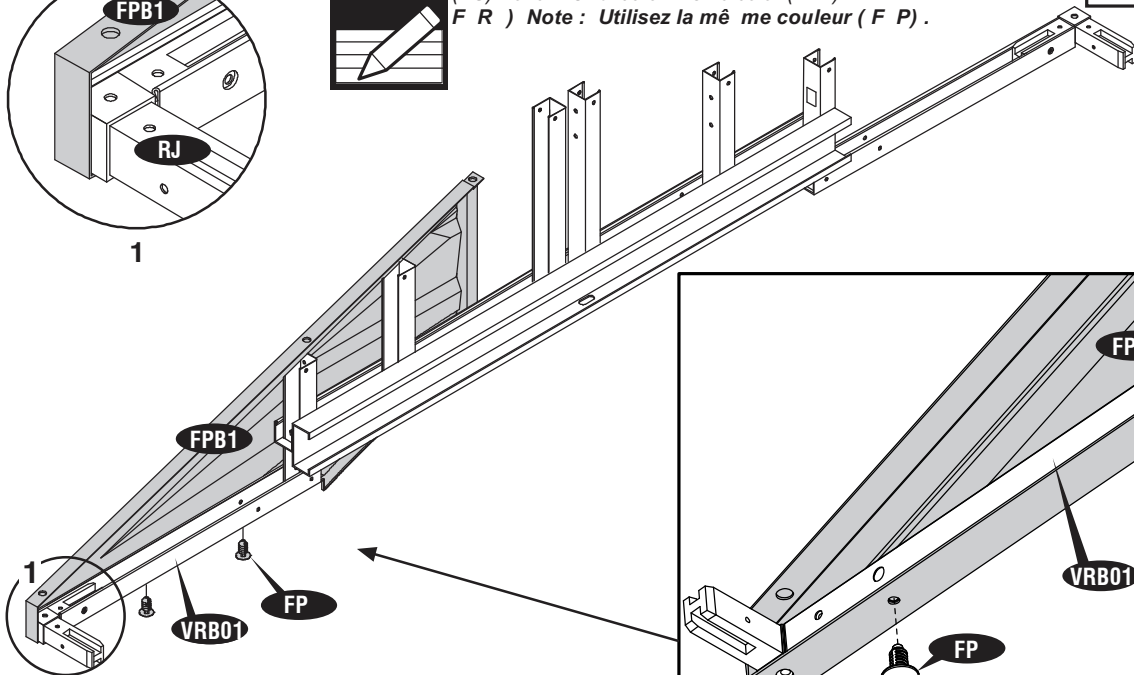

23

( EN ) IMPORTANT : USE HAND GLOVES TO PREVENT INJURY .  
 ( FR ) IMPORTANT : UTILISER LES GANTS POUR PREVENIR LES ACCIDE NTS .

( ES ) IMPORTANTE : GUANTES DE MANO DE USO PARA PREVENIR LA HERIDA .

15

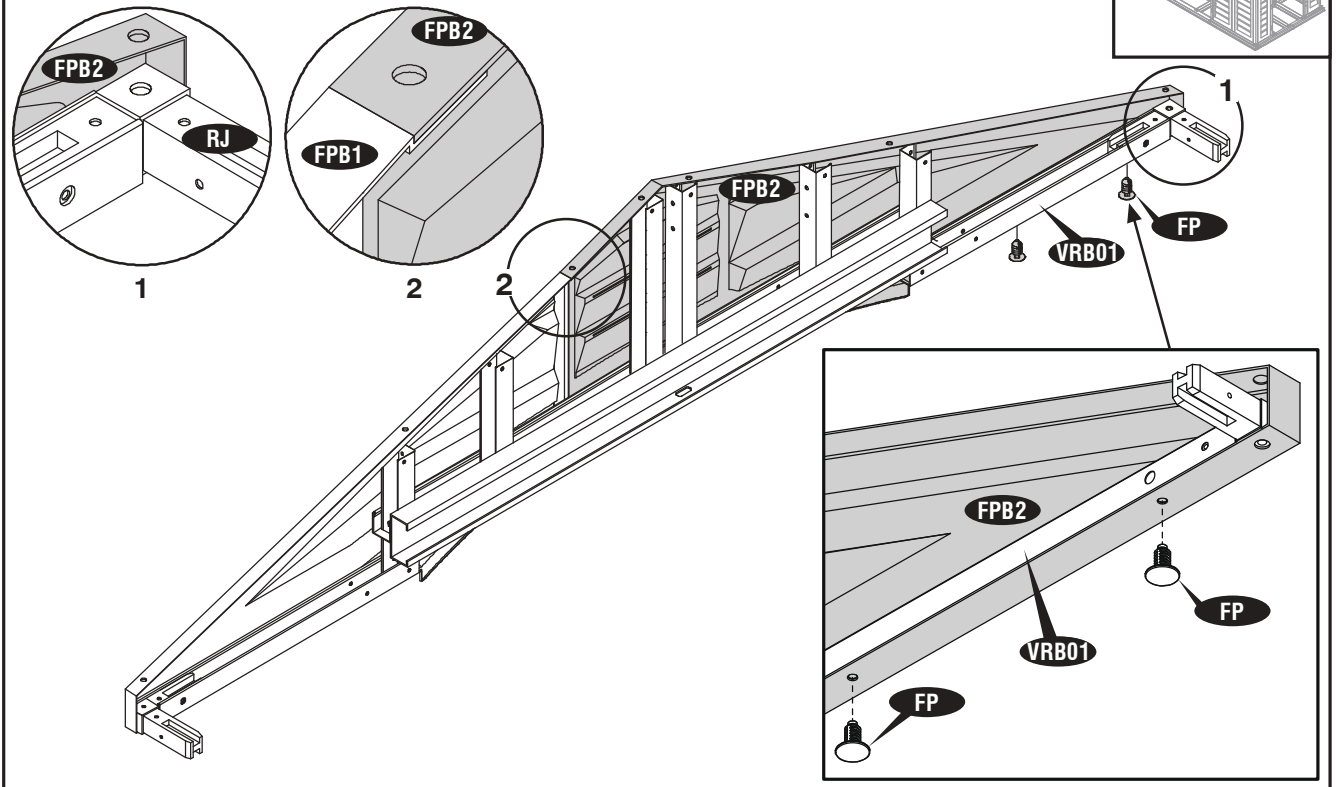
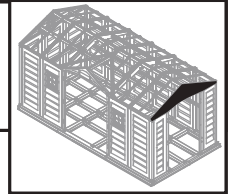
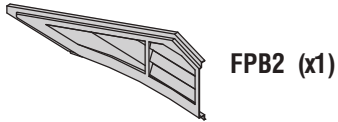

16

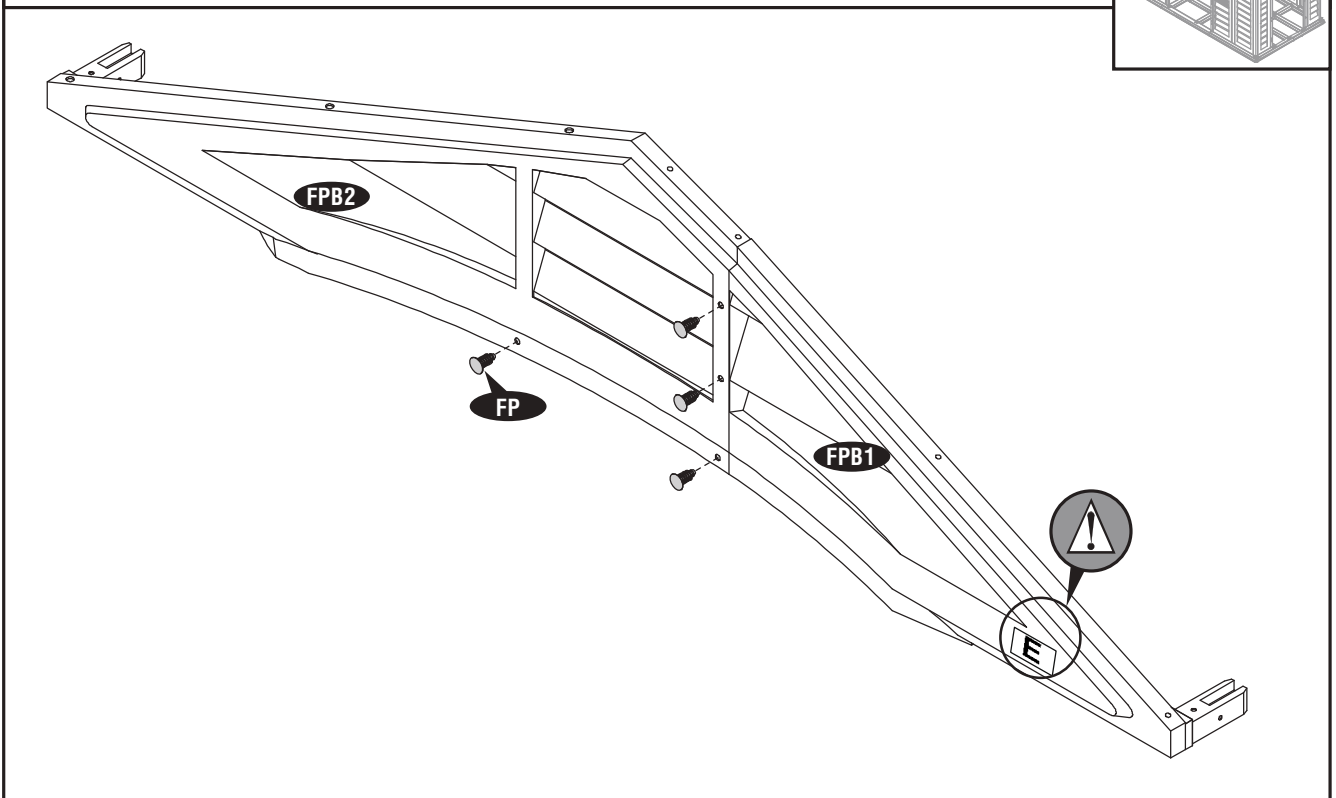
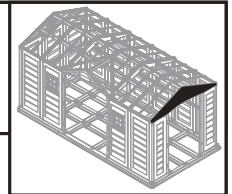

24

(EN) IMPORTANT: USE HAND GLOVES TO PREVENT INJURY.  
 (FR) IMPORTANT: UTILISER LES GANTS POUR PREVENIR LES ACCIDENTS.

(ES) IMPORTANTE: GUANTES DE MANO DE USO PARA PREVENIR LA HERIDA.

17

VRA06 (x2)

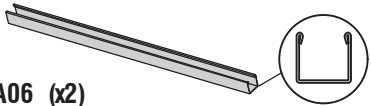

VJA01 (x1)

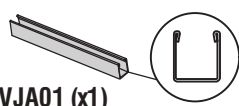

S1 (x2)

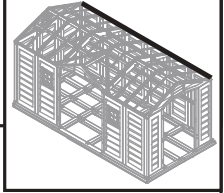

**F** (EN) Roof structure assembly Back  
 (ES) Ensamblaje de estructura de techo posterior  
 (FR) Assemblage de la structure du toit

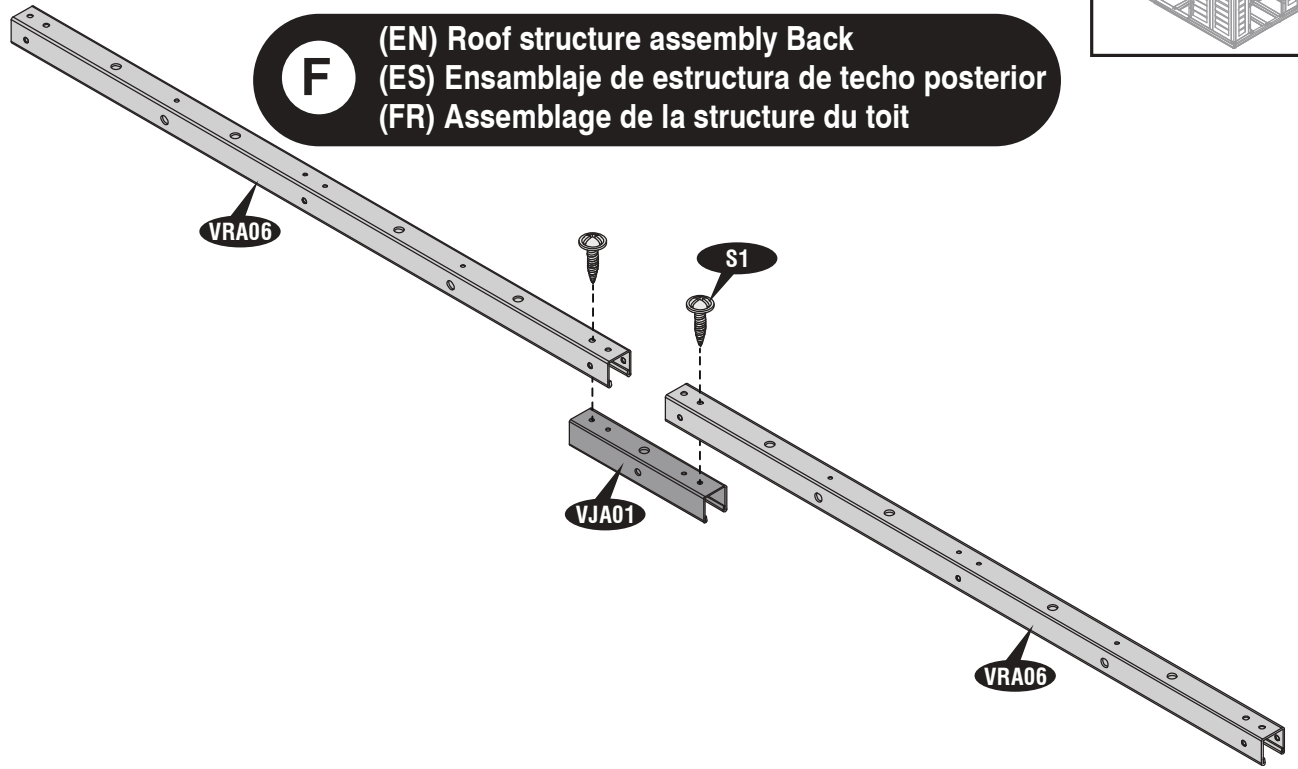

18

VRA06 (x1)

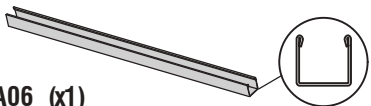

VJA01 (x1)

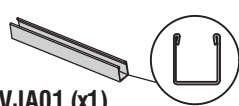

S1 (x2)

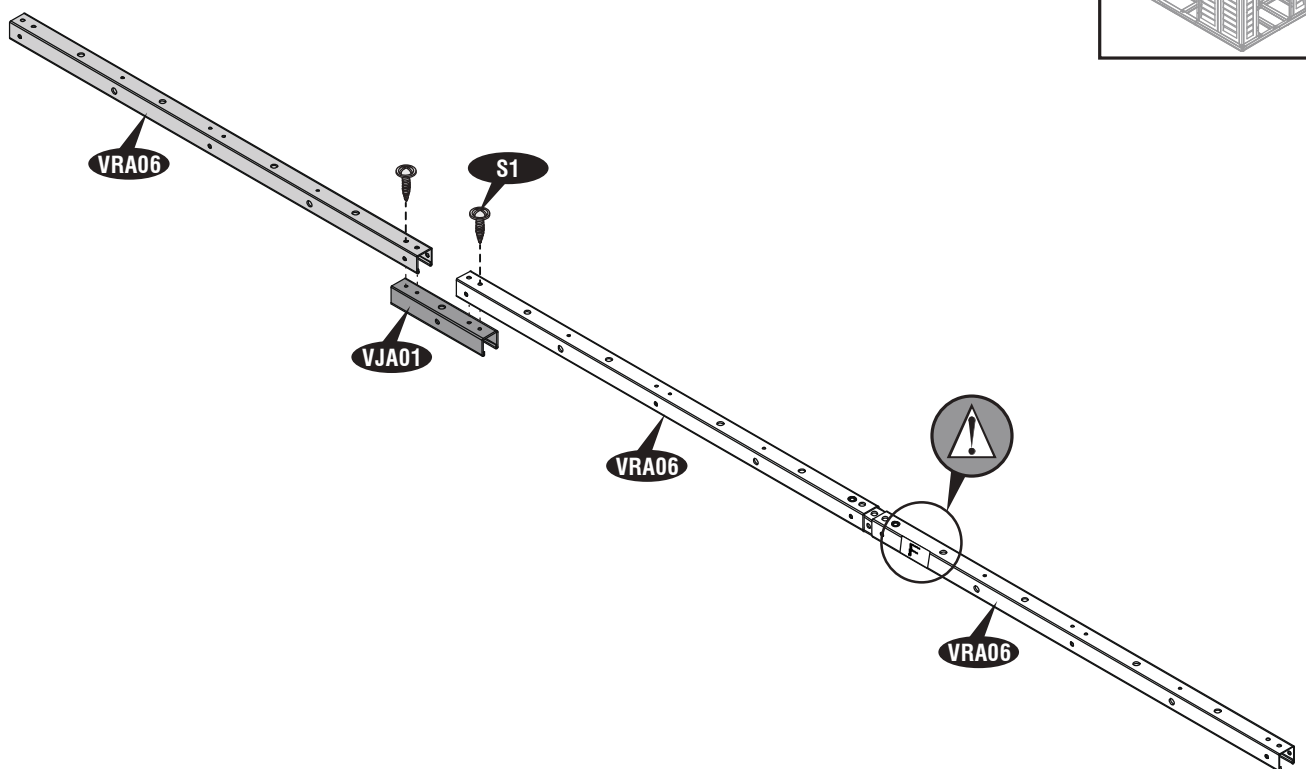
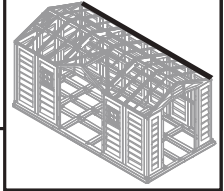

25

(EN) IMPORTANT: USE HAND GLOVES TO PREVENT INJURY.  
 (FR) IMPORTANT: UTILISER LES GANTS POUR PREVENIR LES ACCIDENTS.

(ES) IMPORTANTE: GUANTES DE MANO DE USO PARA PREVENIR LA HERIDA.

19

VRG03 (x1)

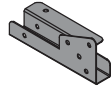
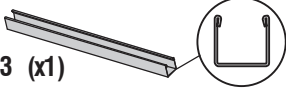

VRG04 (x1)



S7 (x2)

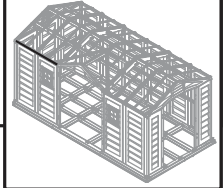

**G**

(EN) Front Roof structure assembly Left  
 (ES) Montaje de la estructura del techo delantero a la izquierda  
 (FR) Assemblage de la structure de toit avant gauche

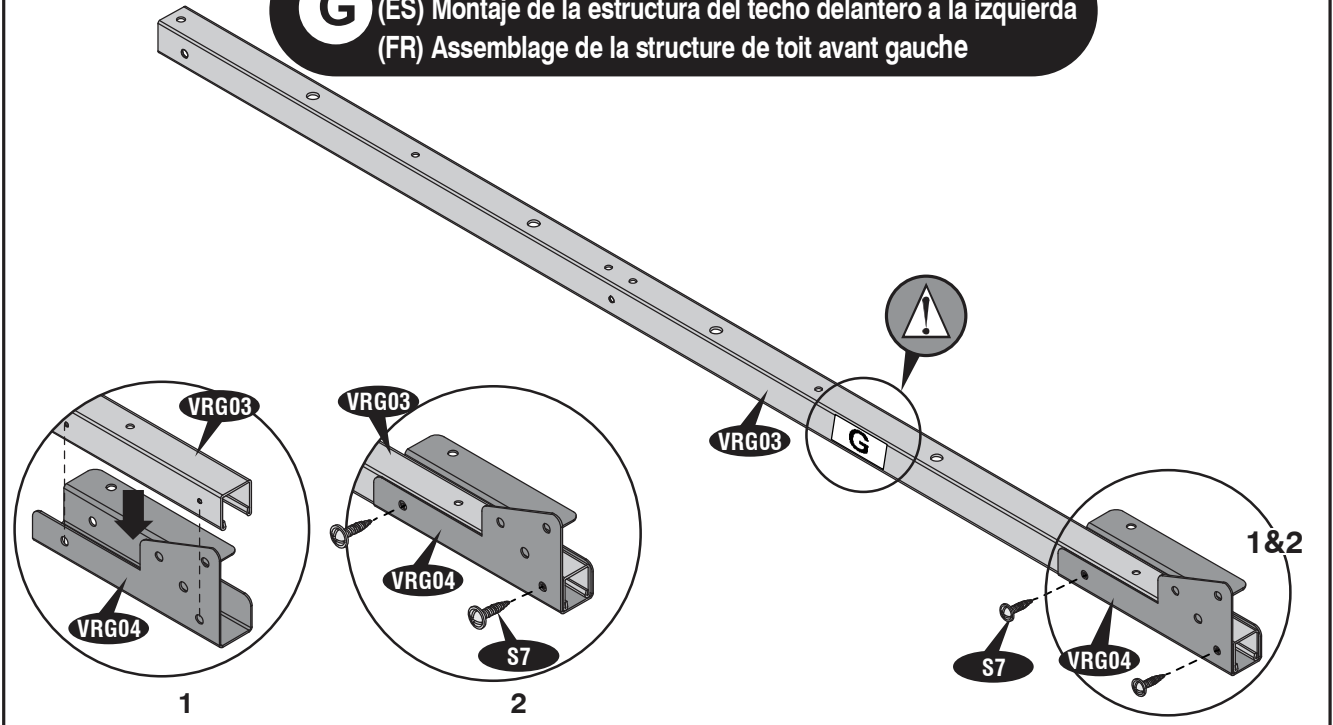

20

VRG03 (x1)

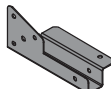
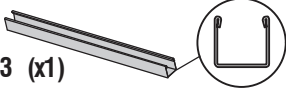

VRG05 (x1)



S7 (x2)

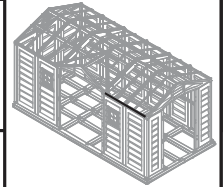

**H**

(EN) Front Roof structure assembly Right  
 (ES) Ensamblaje de estructura de techo frontal derecha  
 (FR) Assemblage de la structure de toit avant droit

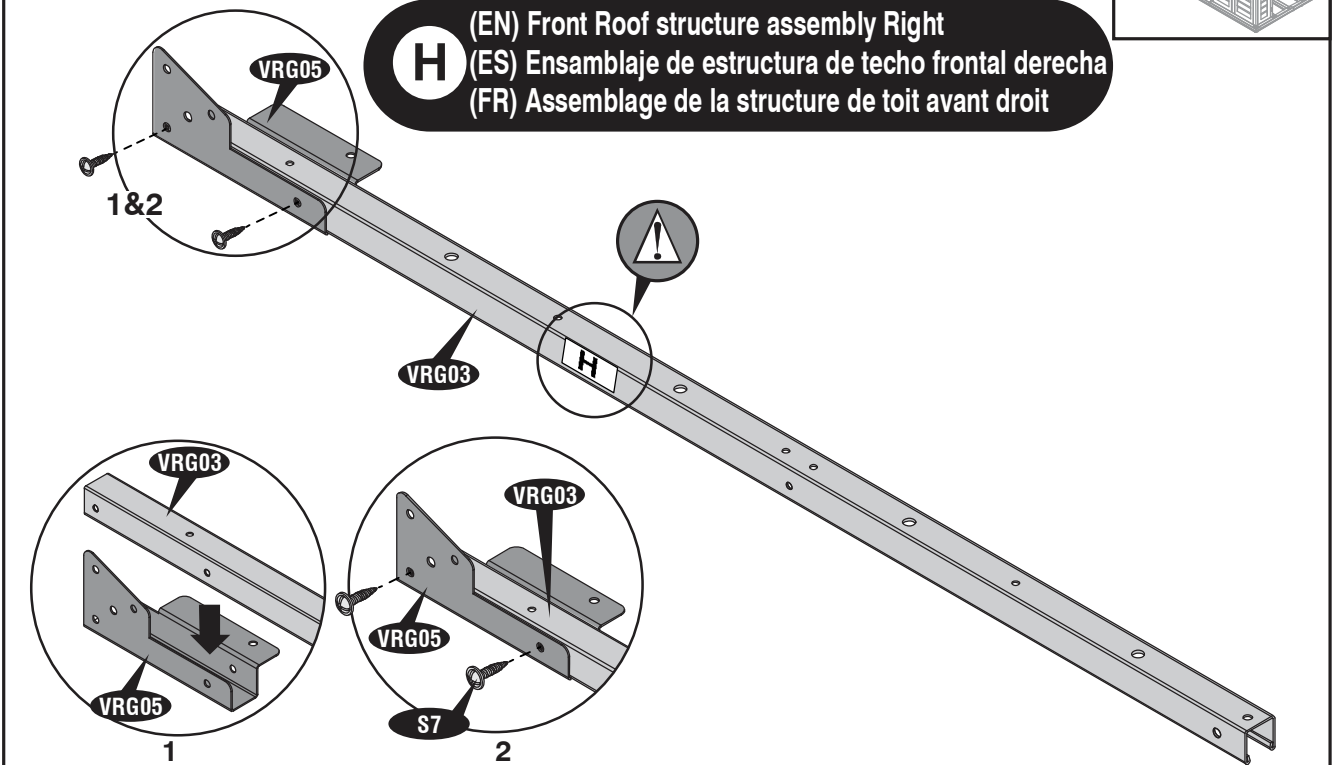

26

(EN) IMPORTANT: USE HAND GLOVES TO PREVENT INJURY.  
 (FR) IMPORTANT: UTILISER LES GANTS POUR PREVENIR LES ACCIDENTS.

(ES) IMPORTANTE: GUANTES DE MANO DE USO PARA PREVENIR LA HERIDA.

VRA36 (x2)  
VRA40 (x1)

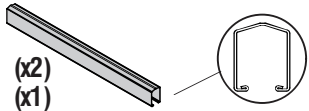

VRA37 (x1)  
VRA41 (x1)

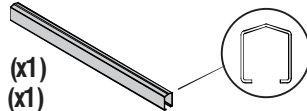

S7 (x40)

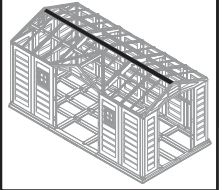

**I** (EN) Roof structure assembly Inside(Middle)  
(ES) Montaje de la estructura del techo Interior (Medio)  
(FR) Assemblage de la structure de toit à l'intérieur (milieu)

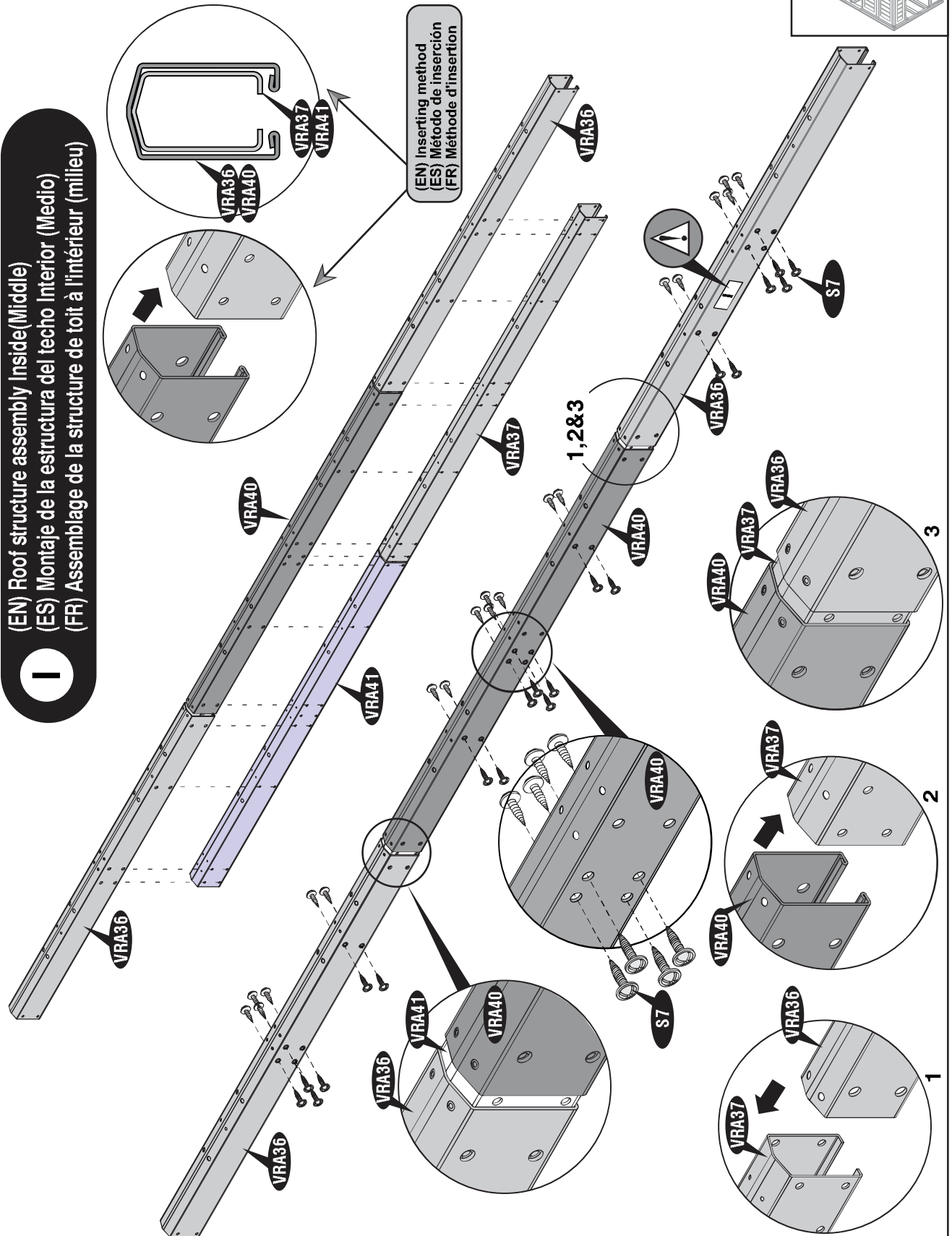

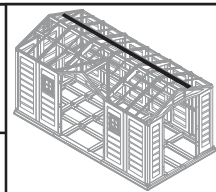
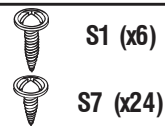
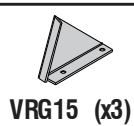

**J**  
(EN) Roof Structure Assembly Inside (Back)  
(ES) Montaje de la estructura del techo interior (parte posterior)  
(FR) Assemblage de la structure du toit à l'intérieur (arrière)

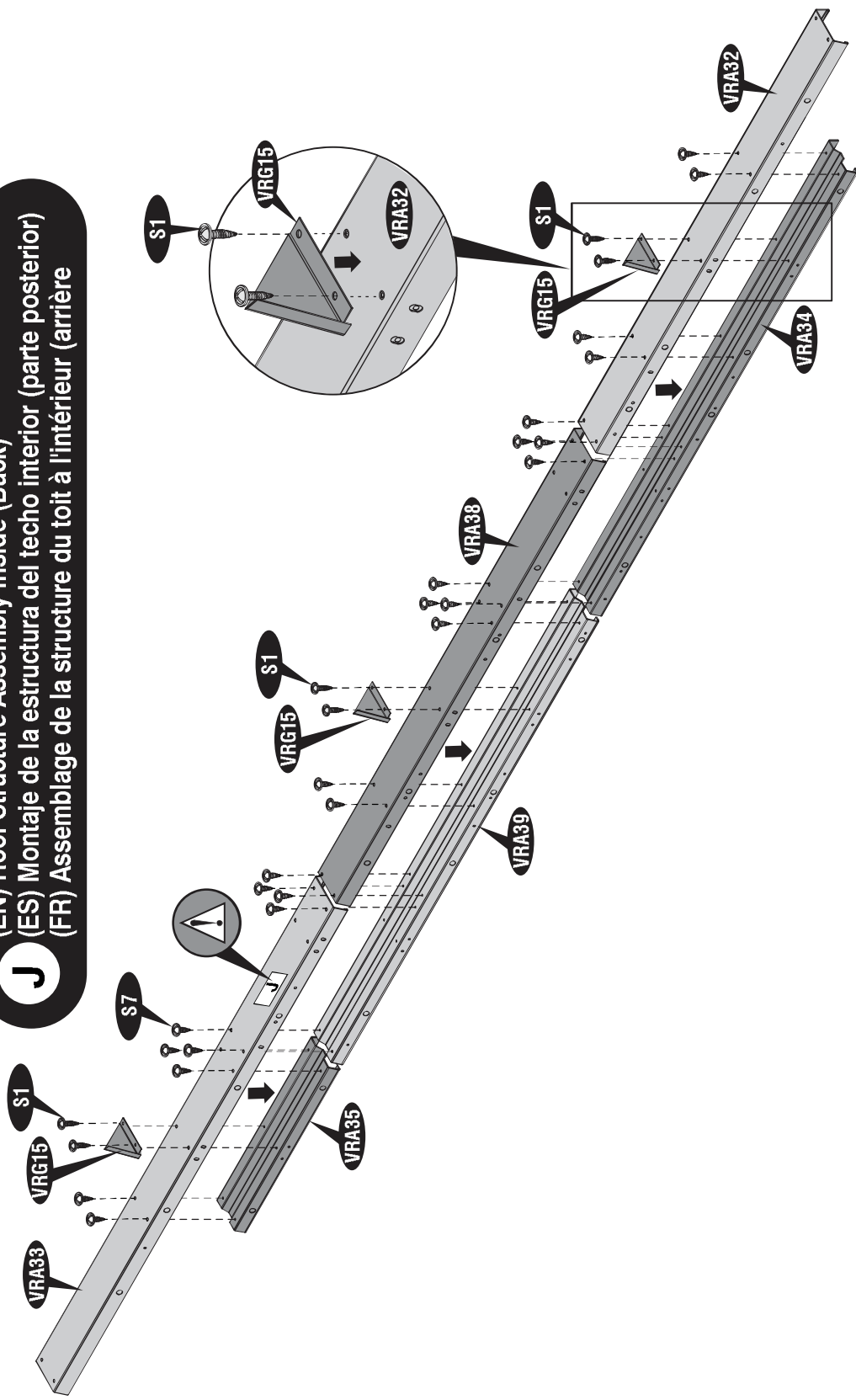

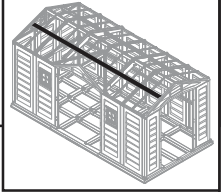
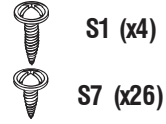
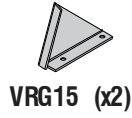
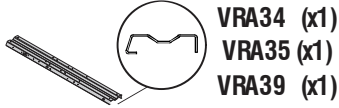

**K**  
(EN) Roof Structure Assembly Inside (Front)  
(ES) Ensamblaje de Estructura de Techo Interior (Frente)  
(FR) Assemblage de la structure du toit à l'intérieur (avant)

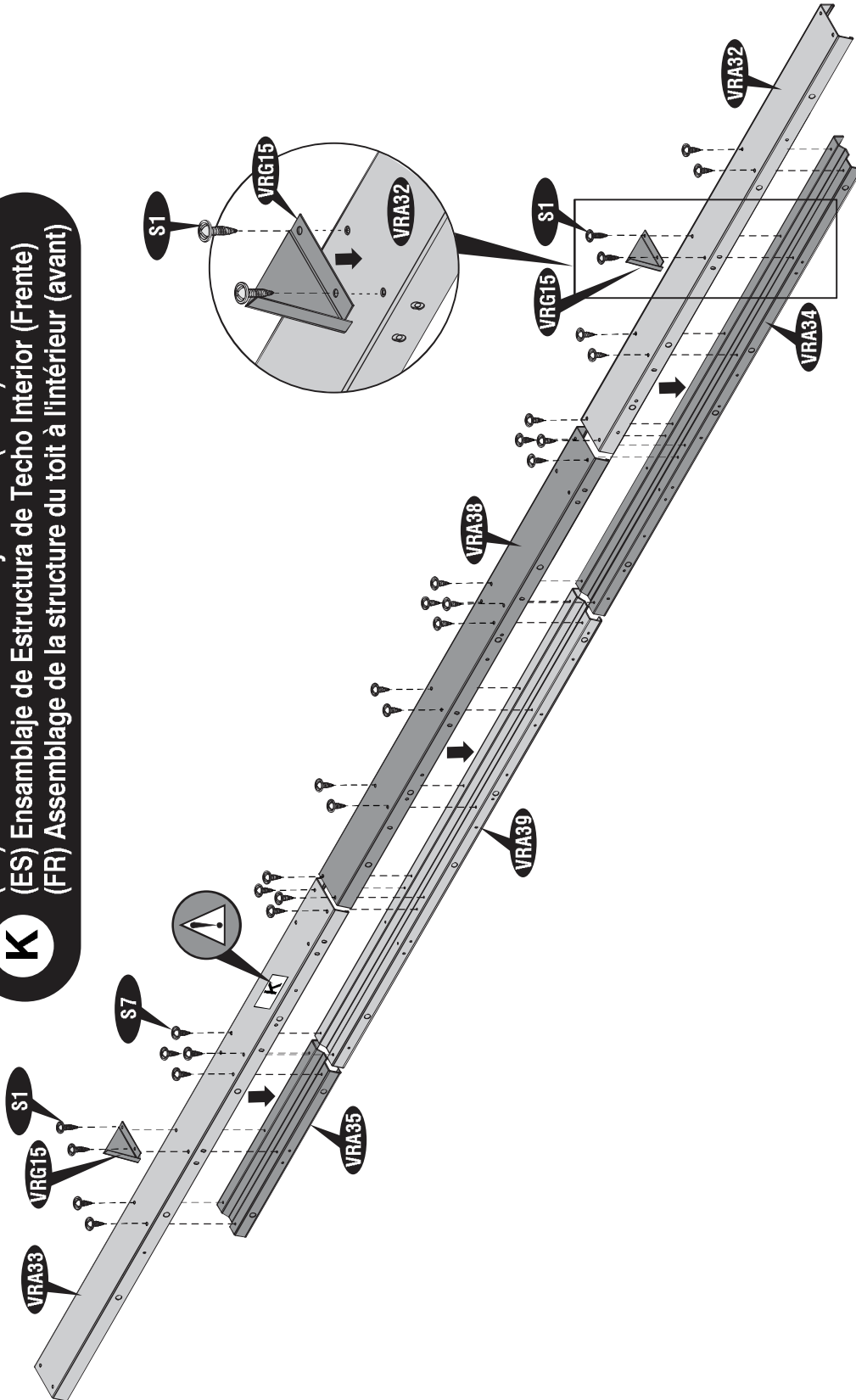

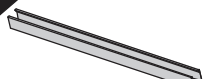
**L****(EN) Front Roof Structure Assembly****(ES) Montaje de la estructura del techo delantero****(FR) Assemblage de la structure du toit avant****24**

VRG08 (x1)



VRG09 (x2)

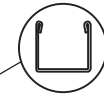

S1 (x2)

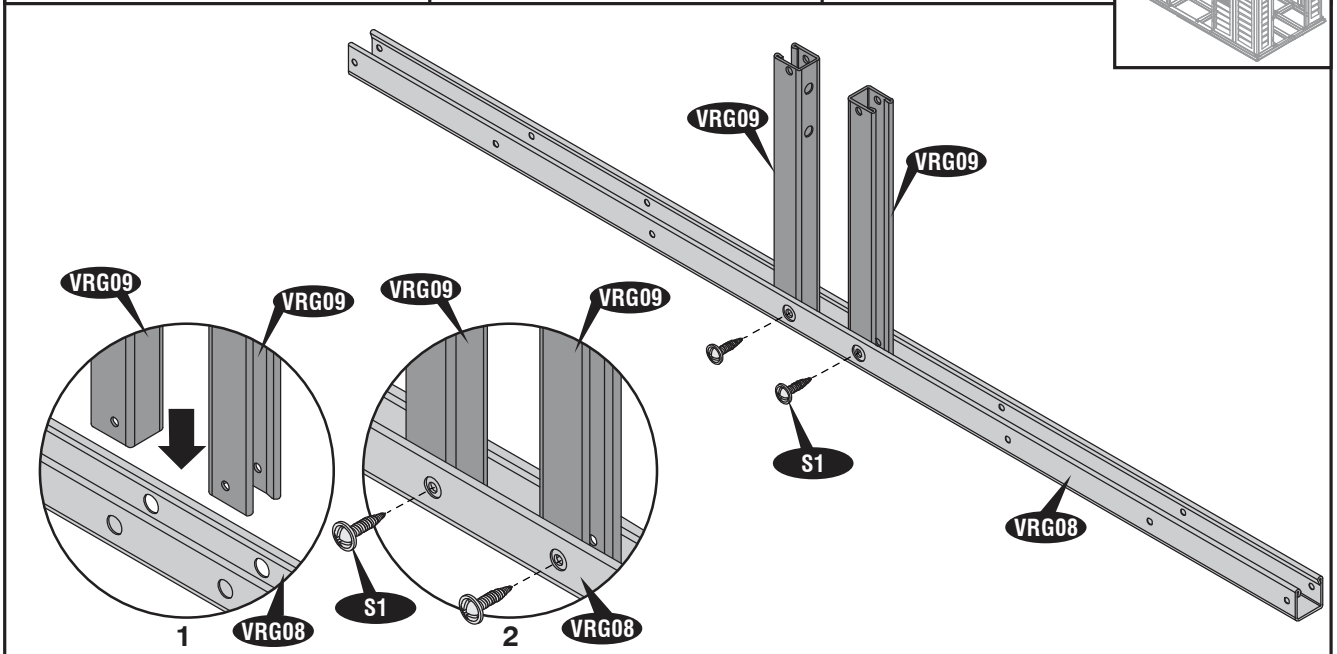
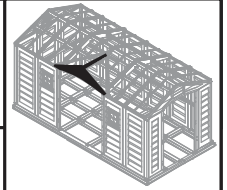
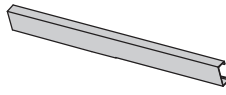
**25**

VRG10 (x1)

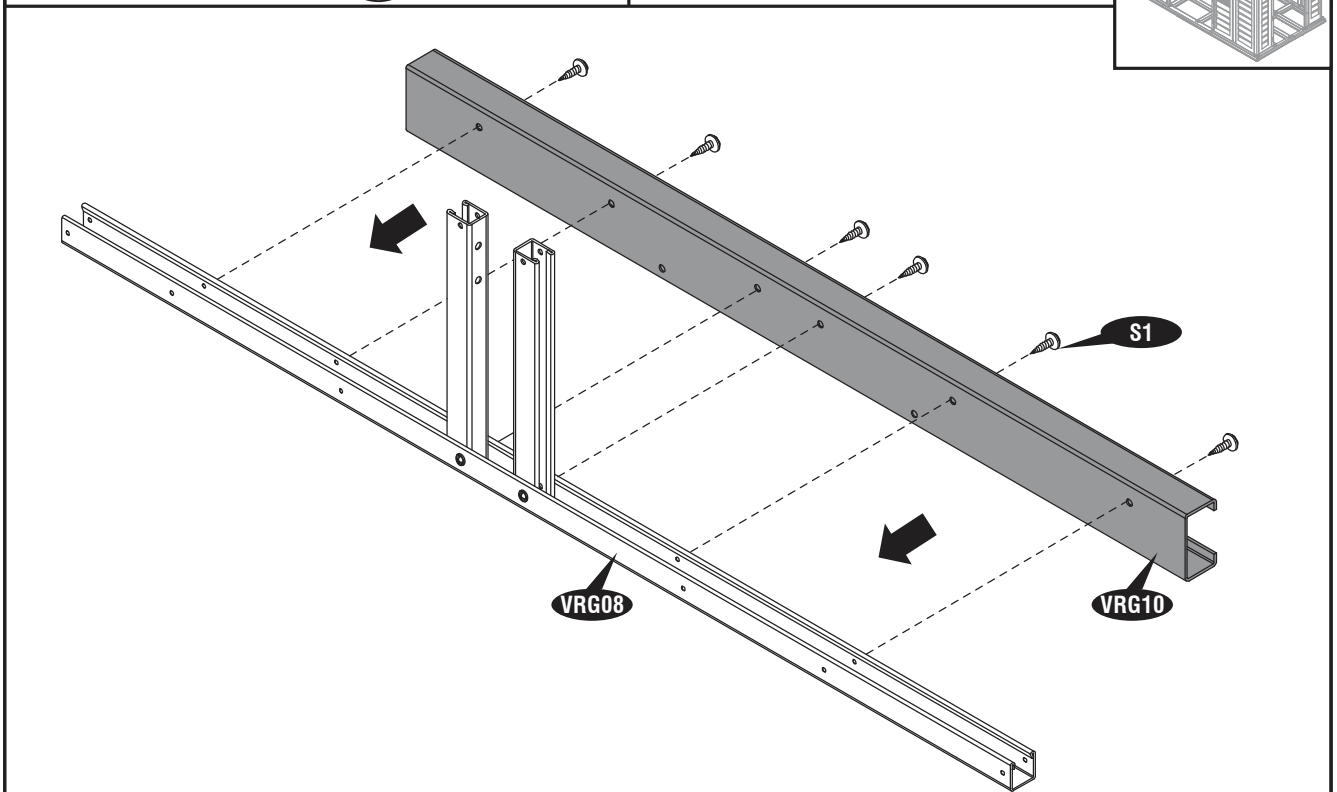
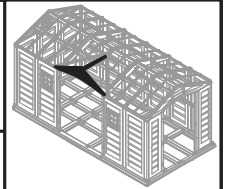

S1 (x6)

**30**

(EN) IMPORTANT: USE HAND GLOVES TO PREVENT INJURY.  
(FR) IMPORTANT: UTILISER LES GANTS POUR PREVENIR LES ACCIDENTS.

(ES) IMPORTANTE: GUANTES DE MANO DE USO PARA PREVENIR LA HERIDA.



26

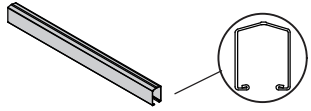

VRG11 (x1)



S1 (x4)

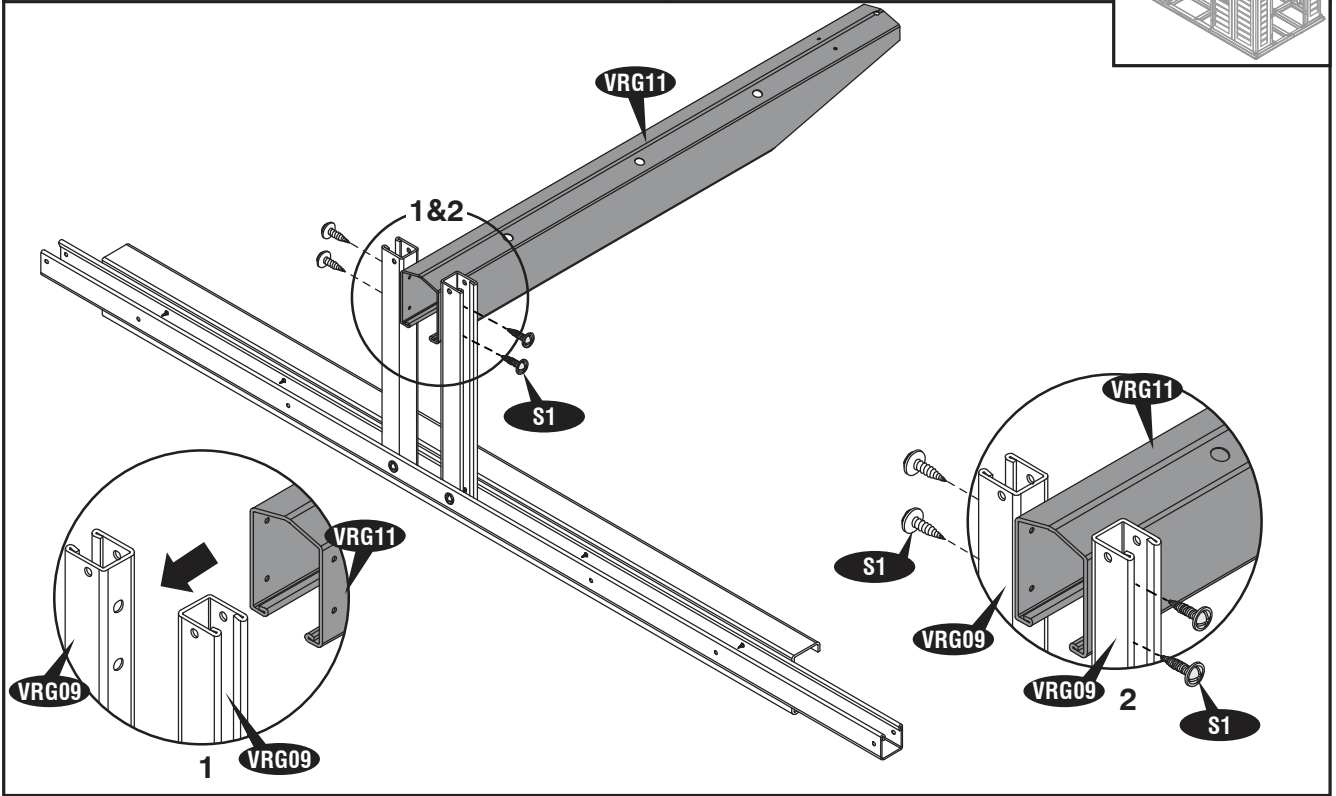
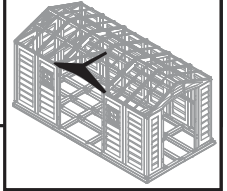

27

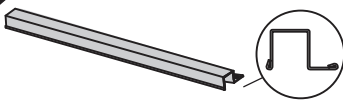

VRG12 (x1)



S7 (x4)

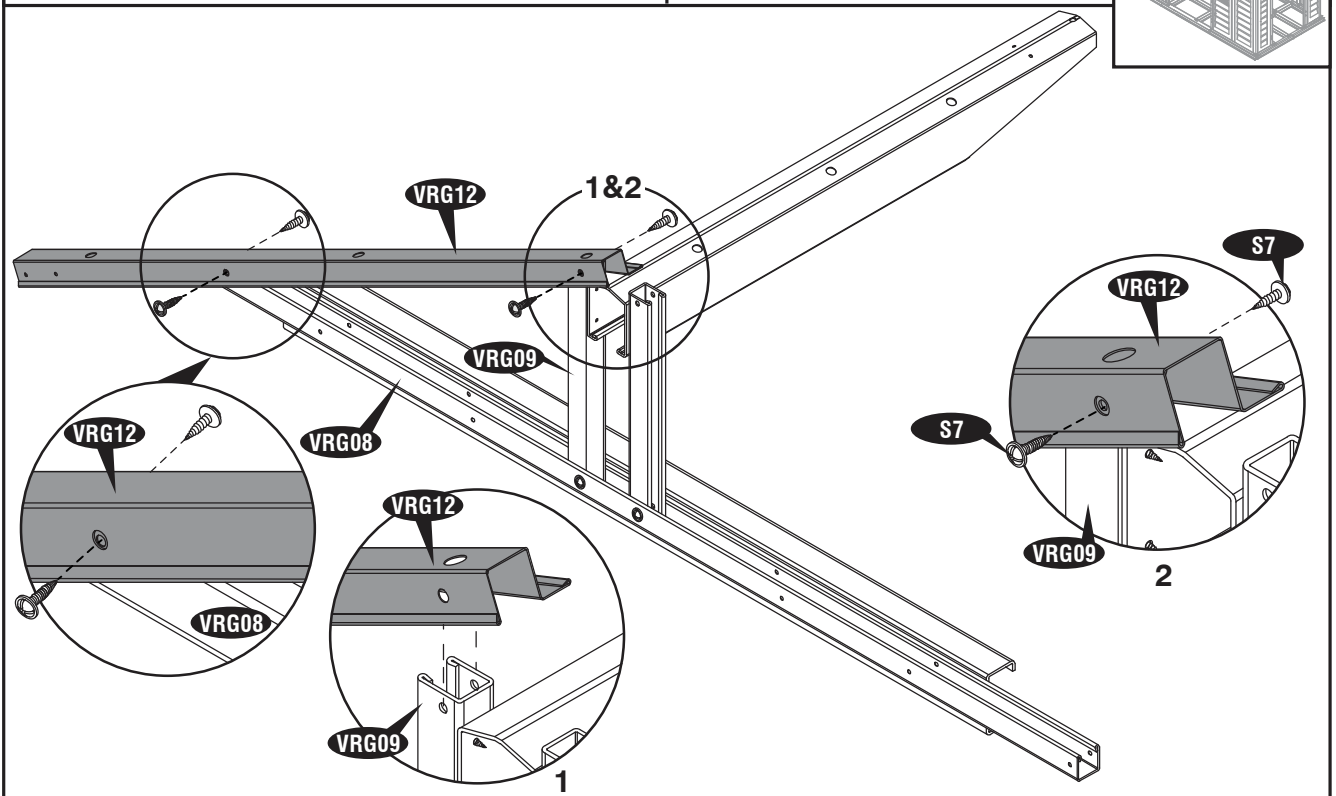
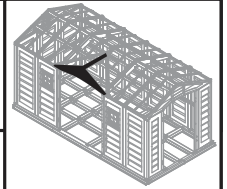

31

(EN) IMPORTANT: USE HAND GLOVES TO PREVENT INJURY.  
(FR) IMPORTANT: UTILISER LES GANTS POUR PREVENIR LES ACCIDENTS.

(ES) IMPORTANTE: GUANTES DE MANO DE USO PARA PREVENIR LA HERIDA.

28

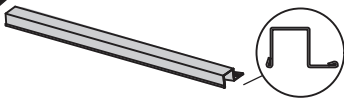

VRG13 (x1)



S7 (x4)

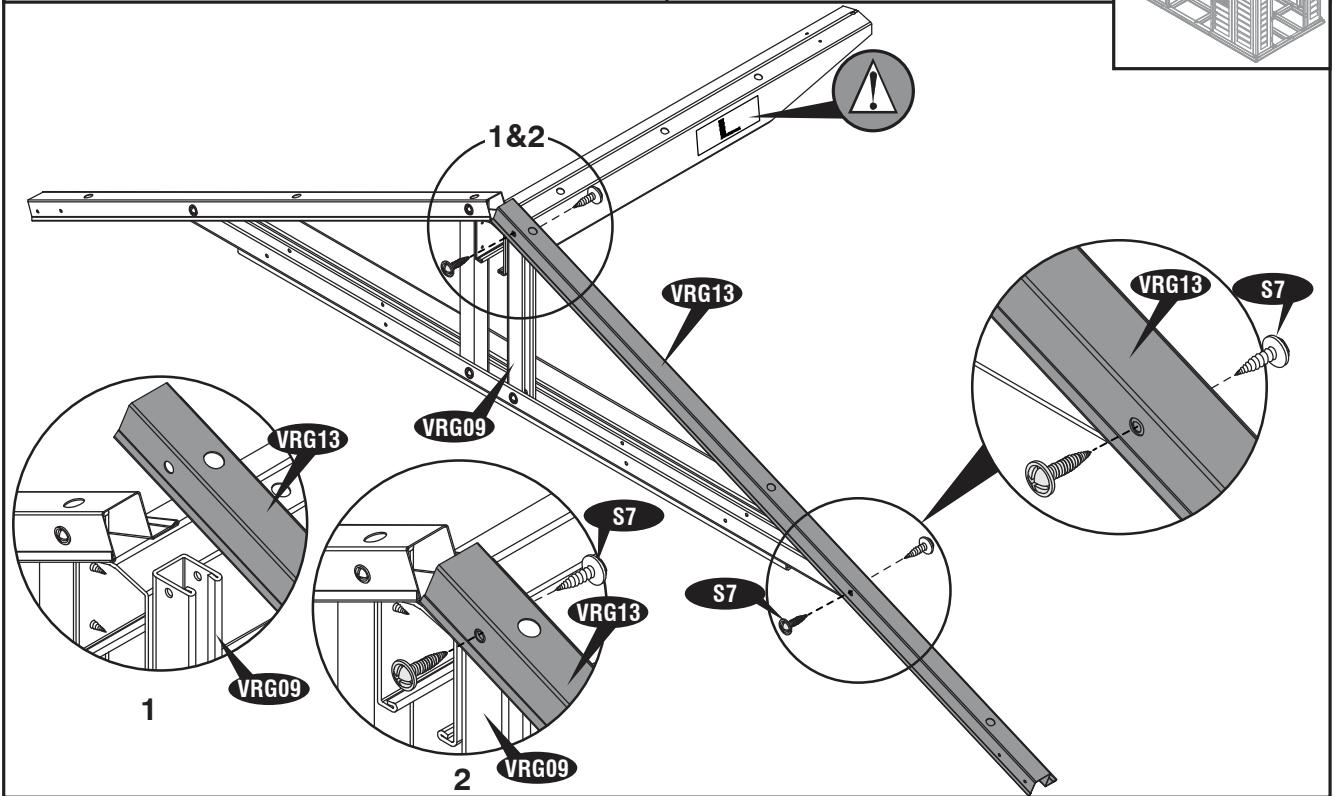
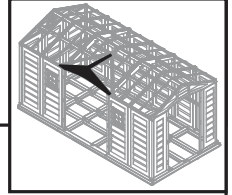

29

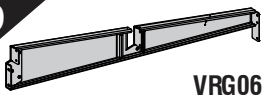

VRG06 (x2)



VRG07 (x2)



S8 (x4)

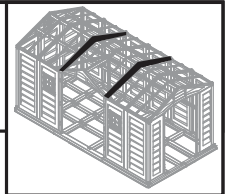

X2

M

(EN) Structure assembly Inside  
(ES) Montaje de la estructura interior  
(FR) Assemblage de la structure à l'intérieur

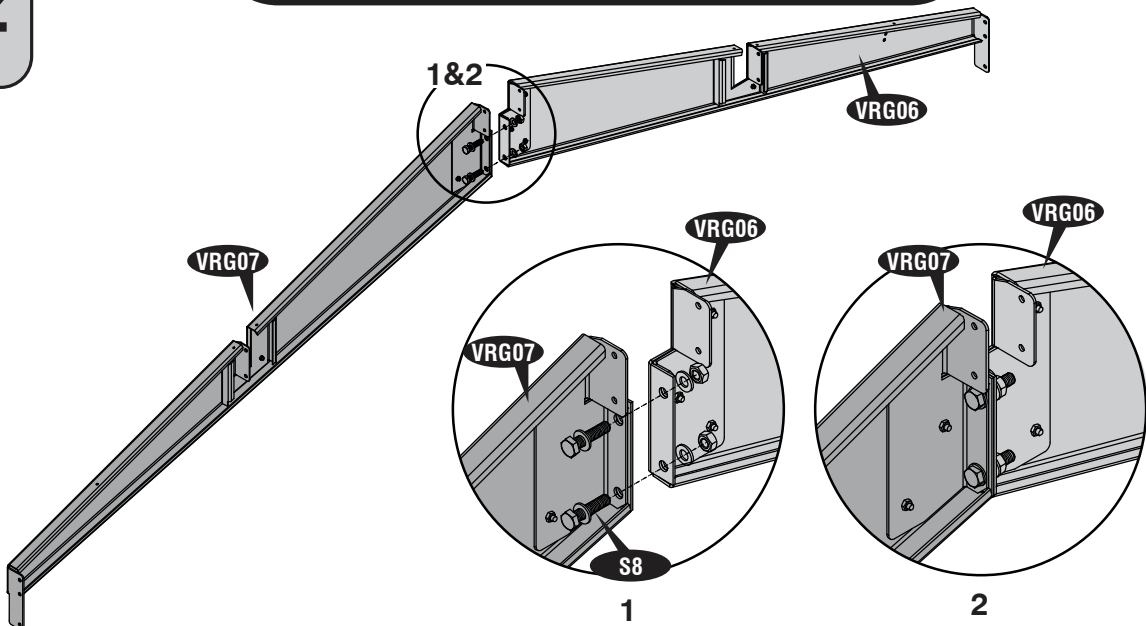

32

(EN) IMPORTANT: USE HAND GLOVES TO PREVENT INJURY.  
(FR) IMPORTANT: UTILISER LES GANTS POUR PREVENIR LES ACCIDENTS.

(ES) IMPORTANTE: GUANTES DE MANO DE USO PARA PREVENIR LA HERIDA.

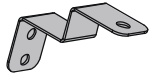

G06D (x2)



S3 (x4)

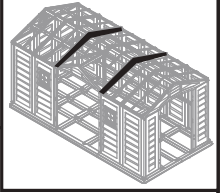

X2

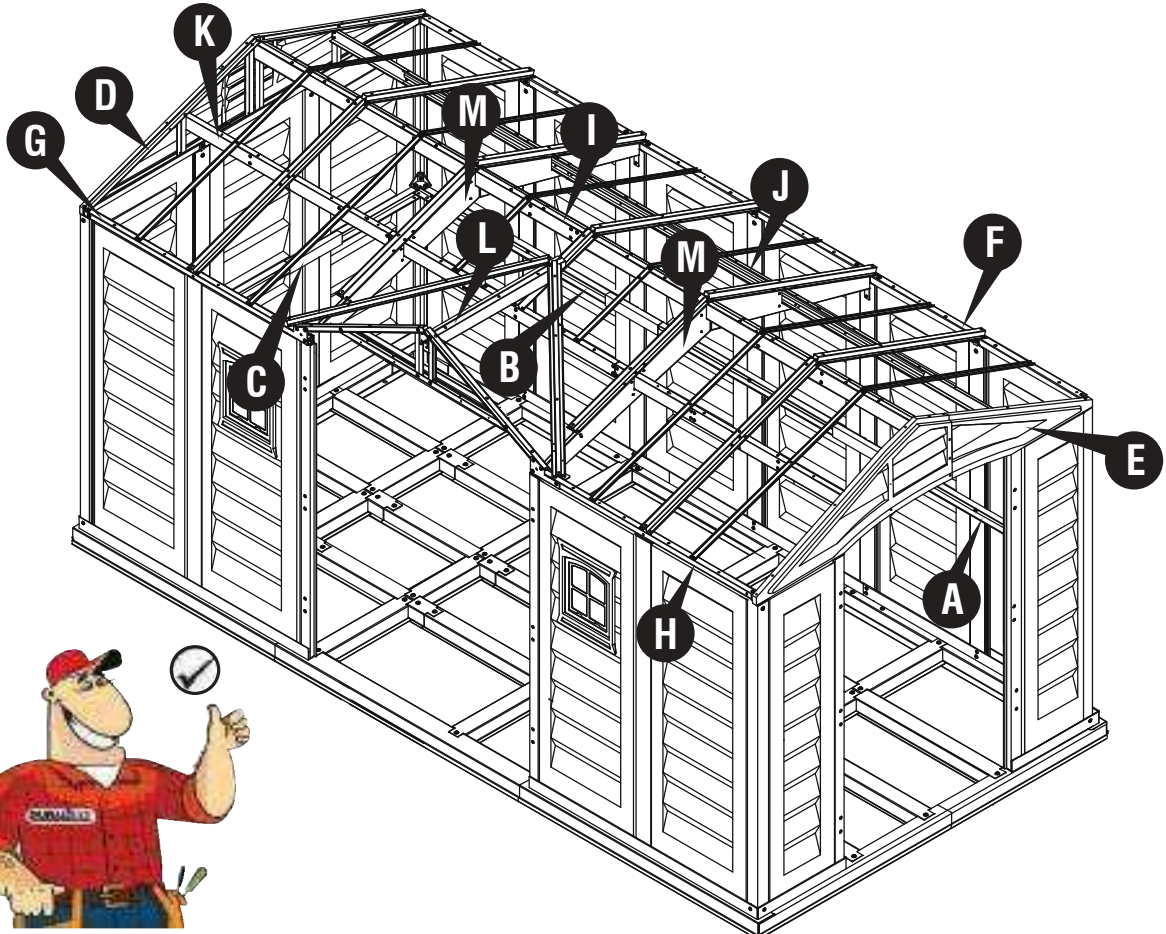
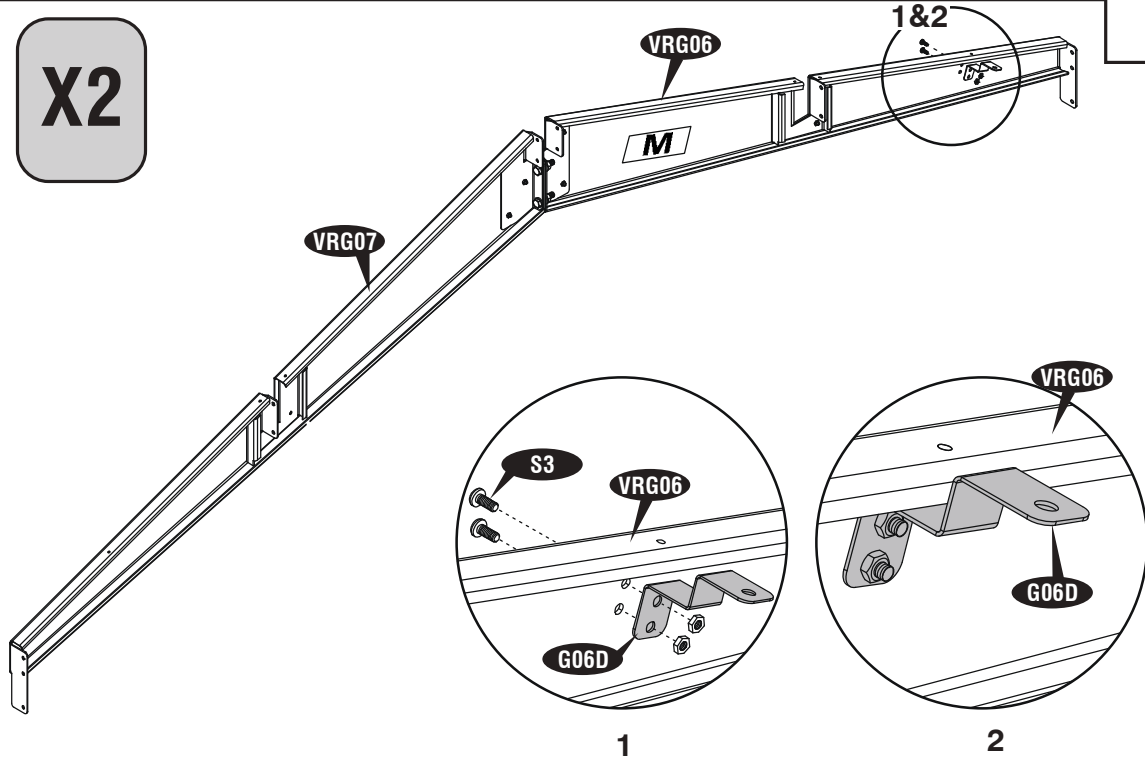



**4**

**(EN) Walls & Columns  
(ES) Las paredes & las Columnas  
(FR) Murs et montants**



**(EN) : All parts are clearly marked and care should be taken to use the correct one. Two shatter proof window panel (WPA2†) included. This can be used in any of the wall positions(WPA1†).**

**(ES) : Todo pone piezas son marcados claramente y cuidan debe ser tomado para usar el corrige uno.**

*Un panel de la ventana irrompible (WPA2†) incluido. Esto se puede utilizar en cualquiera de las posiciones de la pared(WPA1†).*

**(FR) : Toutes les pièces sont clairement identifiées et il faut veiller à utiliser la bonne. Le panneau de fenêtre (WPA2†) peut-être utilisé sur toutes les face des murs(WPA1†).**

**(EN) Parts needed  
(ES) Las partes necesitaron  
(FR) Pièces nécessaires**

(EN)CODE (ES)CODE (FR)CODE	(EN)QTY (ES)QTY (FR)QTÉ	(EN)CODE (ES)CODE (FR)CODE	(EN)QTY (ES)QTY (FR)QTÉ
CLA1	1	WPA2†	2
CLA2	4	WPB1†	2
CLA3	7	A	1
CLA4	1	B	1
CLG1	1	C	1
CLG2	1	CBC	3
CLG3	2	FCB	4
VCG01	2	EPS	4
VCG03	2	S1	61
WPA1†	11	S2	4

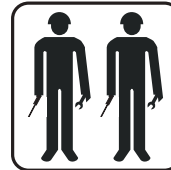

**(EN) Two people needed.**

**(ES) Dos personas que se necesitan.**

**(FR) Deux personnes nécessaires.**

(EN) Column and Panel Assembly Method	(ES) Columna y el método de montaje de Panel	(FR)Colonne et méthode de montage panneau
<p><b>(EN) Lock the panel into the column from top to bottom.</b>  <b>(ES) Trabe el panel en la columna de arriba a abajo.</b>  <b>(FR) Verrouiller le panneau dans la colonne de haut en bas.</b></p>		<p><b>(EN) Inside View (ES) Vista Interior (FR) l'intérieur de vue</b></p>

**1**

CLA2 (x1)

S1 (x2)

(E N) M ak e sure that, the arrow mark points up.  
 (ES) Asegúrese de, marca de la flecha apunte hacia arriba.  
 (FR) Assurez-vous que la flèche pointe vers le haut.

(EN) Right  
 (ES) Correcta  
 (FR) Partie droite

2 & 3

2

3

**2**

WPB1↑ (x1)

(EN) Note : Check the stamped label on top of all panels inside.  
 (E S) Pozor : R e vise la etiqueta estampada en la parte superior de todos los paneles interiores.  
 (FR) Note : Vérifiez l'étiquette apposée sur tous les panneaux sur la partie intérieure supérieure.

(EN) Right  
 (ES) Correcta  
 (FR) Partie droite

3

4

35

3

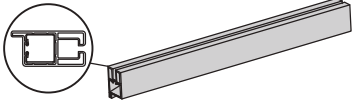

CLA1 (x1)



S1 (x2)

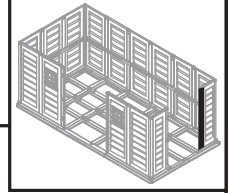

(EN) Needed to hold the panel at this step.  
(ES) Necesario para sostener el panel en este paso.  
(FR) Nécessaire pour maintenir le panneau à cette étape.

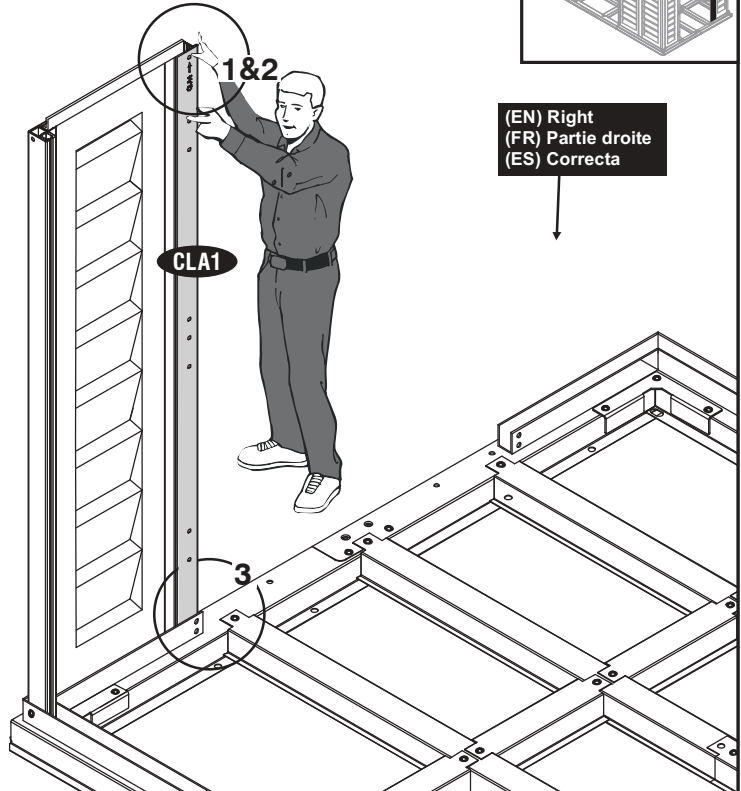
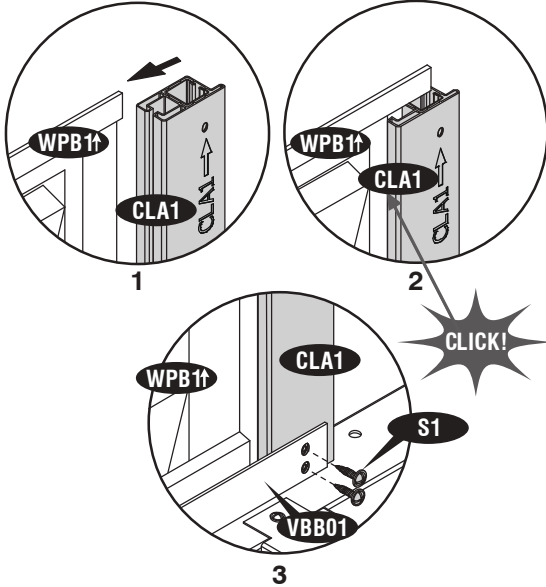

4

FCB(x1)

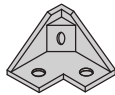

S2 (x1)

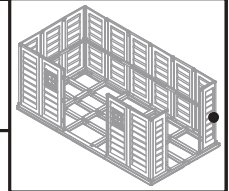

(EN) Needed to hold the panel at this step.  
(ES) Necesario para sostener el panel en este paso.  
(FR) Nécessaire pour maintenir le panneau à cette étape.

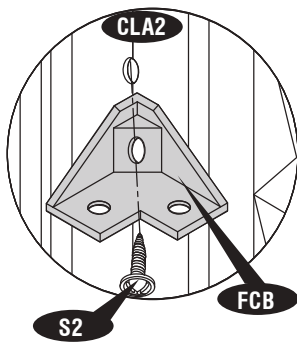

(EN) Back  
(ES) Detrás  
(FR) Arrière

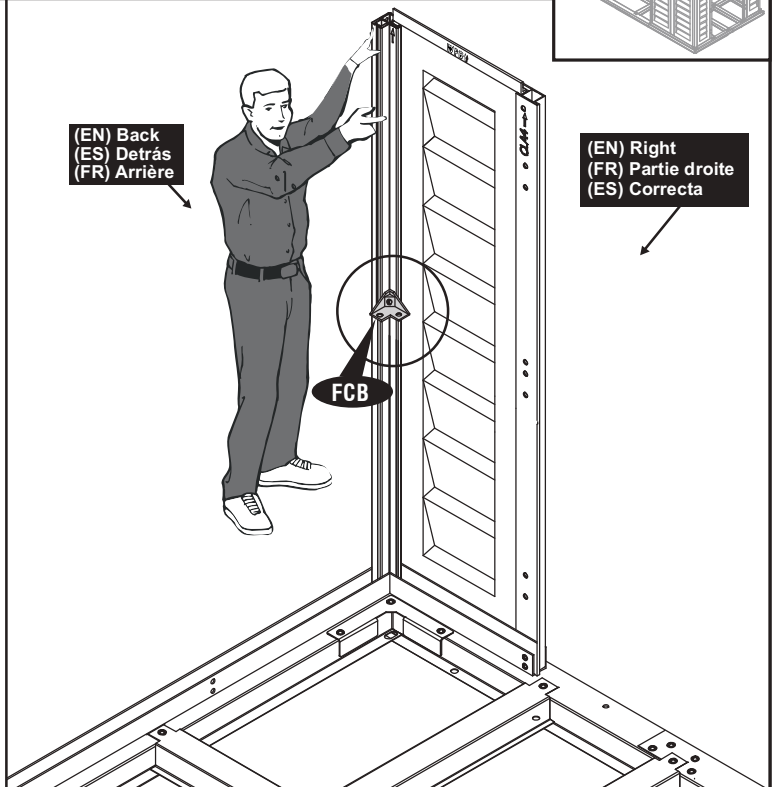

(EN) Do not tighten the screw. Leave it loose.  
(ES) No apriete el tornillo. Déjalo suelto.  
(FR) Ne pas serrer la vis. Laissez le lâche.

36

(EN) IMPORTANT: USE HAND GLOVES TO PREVENT INJURY.  
(FR) IMPORTANT: UTILISER LES GANTS POUR PREVENIR LES ACCIDENTS.

(ES) IMPORTANTE: GUANTES DE MANO DE USO PARA PREVENIR LA HERIDA.

**5**

VCG01 (x1)

S1 (x2)

EPS (x1)

(EN) Needed to hold the panel at this step.  
 (ES) Necesario para sostener el panel en este paso.  
 (FR) Nécessaire pour maintenir le panneau à cette étape.

(EN) Back  
 (ES) Detrás  
 (FR) Arrière

(EN) Right  
 (FR) Partie droite  
 (ES) Correcta

1

2

3

1

2&3

FCB

VCG01

EPS

**6**

WPA1↑ (x1)

CLA3 (x1)

S1 (x2)

(EN) Back  
 (ES) Detrás  
 (FR) Arrière

(EN) Right  
 (FR) Partie droite  
 (ES) Correcta

CLICK!

CLICK!

1

2

3

4

5

1&2

3&4

5

WPA1↑

CLA2

CLA3

CLA3

CLA3

S1

VBA04

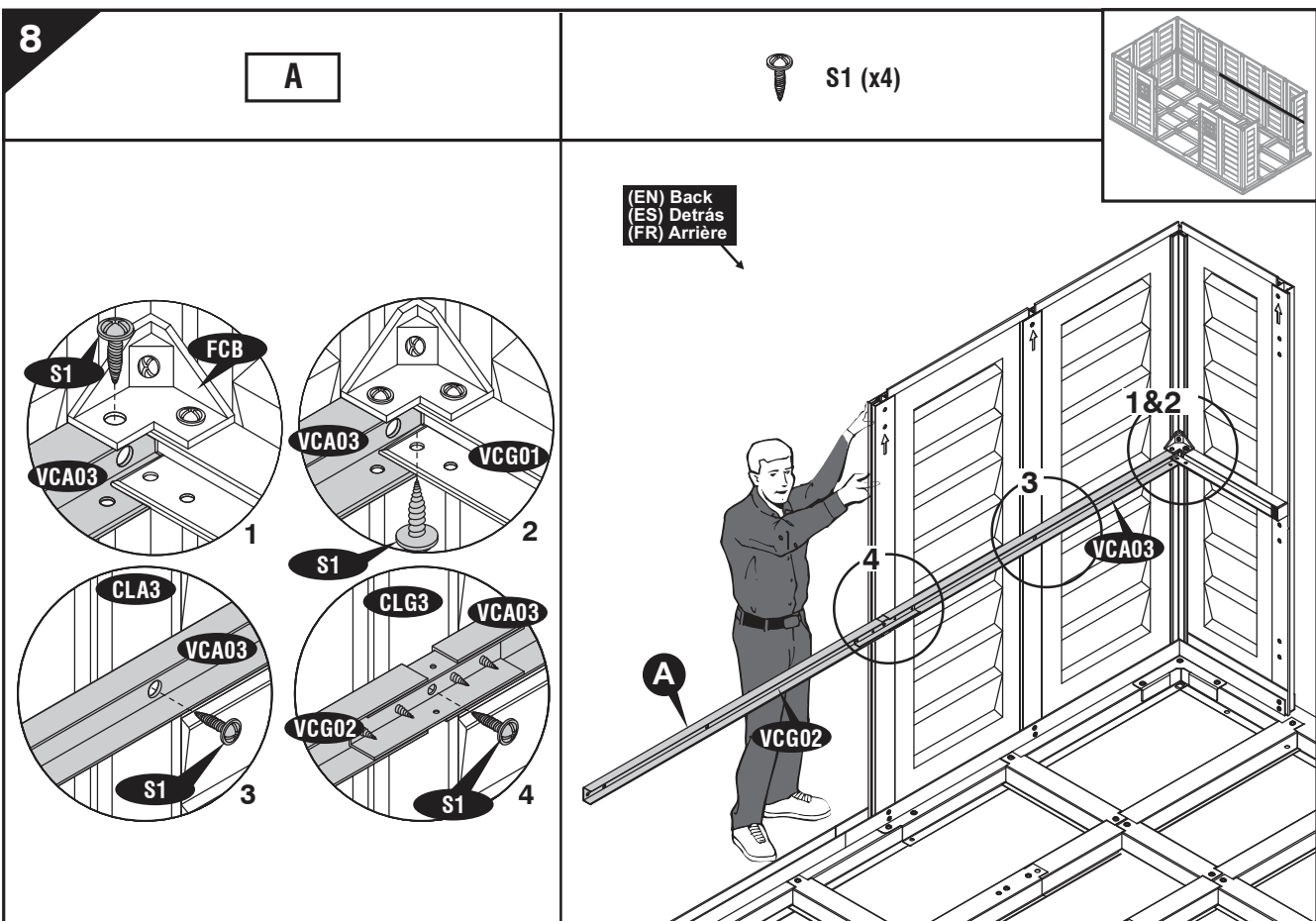
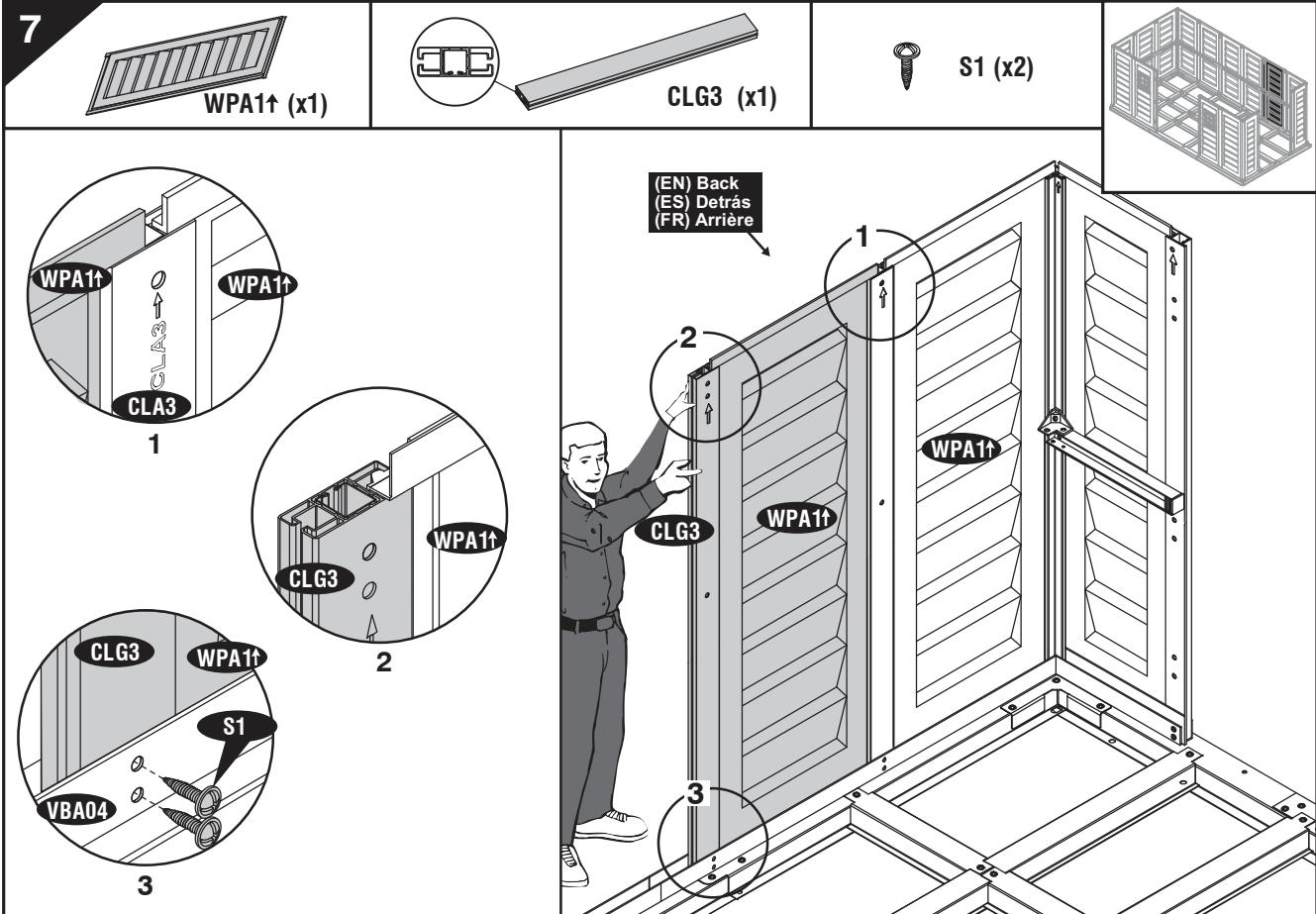



**9**

WPA1↑ (x1)    CLA3 (x1)    CBC (x1)    S1 (x3)

(EN) Back  
(ES) Detrás  
(FR) Arrière

**10**

B

S1 (x2)

(EN) Needed to hold the panel at this step.  
(ES) Necesario para sostener el panel en este paso.  
(FR) Nécessaire pour maintenir le panneau à cette étape.

(EN) Back  
(ES) Detrás  
(FR) Arrière

11

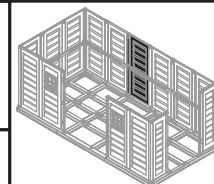
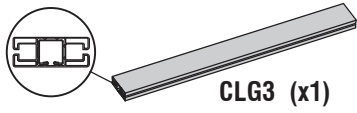

(EN) Needed to hold the panel at this step.  
 (ES) Necesario para sostener el panel en este paso.  
 (FR) Nécessaire pour maintenir le panneau à cette étape.

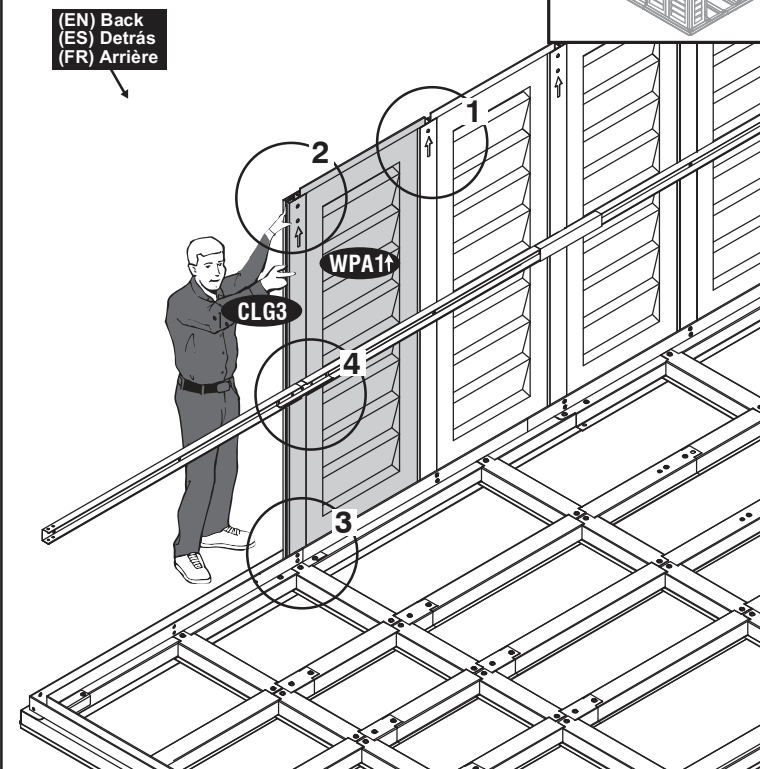
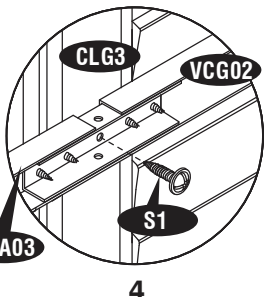
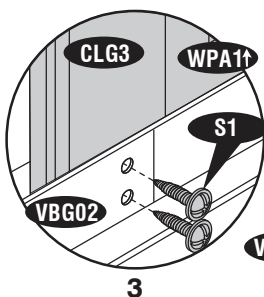
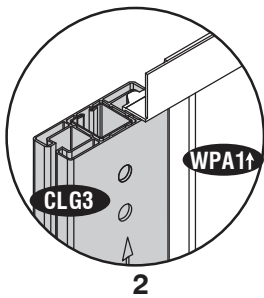
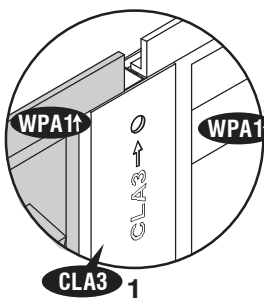

12

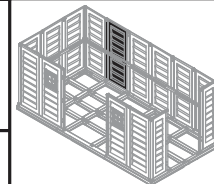
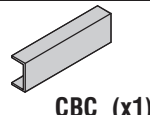
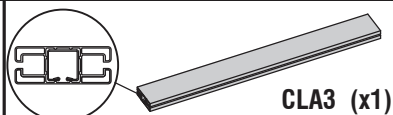

(EN) Needed to hold the panel at this step.  
 (ES) Necesario para sostener el panel en este paso.  
 (FR) Nécessaire pour maintenir le panneau à cette étape.

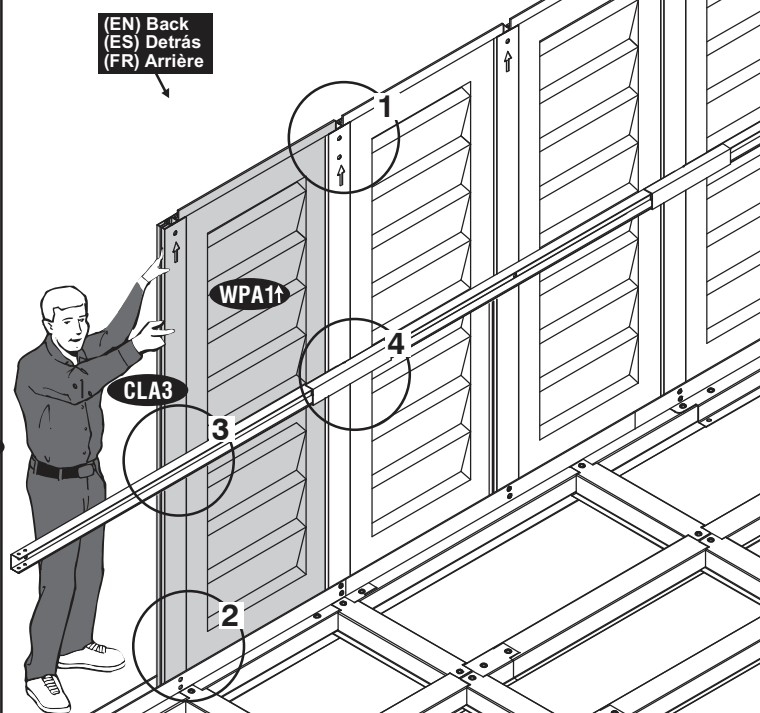
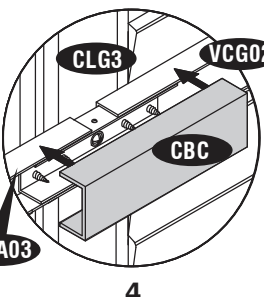
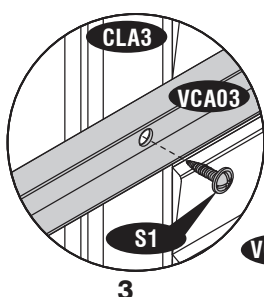
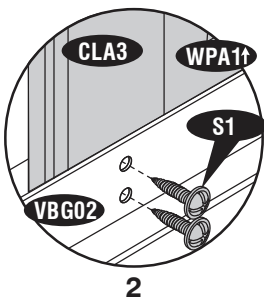
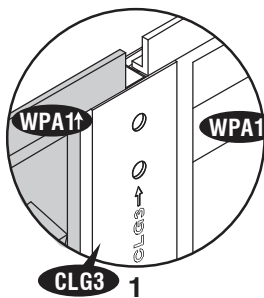

40

(EN) IMPORTANT: USE HAND GLOVES TO PREVENT INJURY.  
 (FR) IMPORTANT: UTILISER LES GANTS POUR PREVENIR LES ACCIDENTS.

(ES) IMPORTANTE: GUANTES DE MANO DE USO PARA PREVENIR LA HERIDA.

13

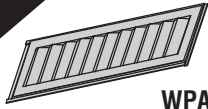

WPA1↑ (x1)

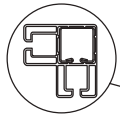

CLA2 (x1)



S1 (x2)

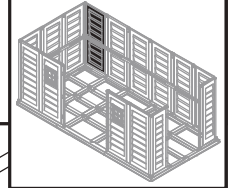

(EN) Needed to hold the panel at this step.  
 (ES) Necesario para sostener el panel en este paso.  
 (FR) Nécessaire pour maintenir le panneau à cette étape.

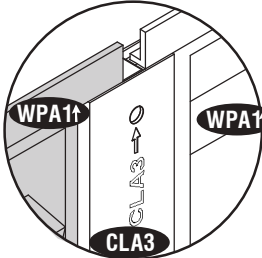

1

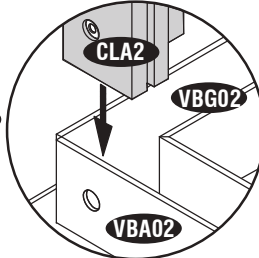

2

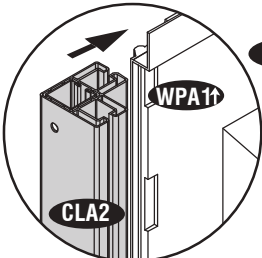

3

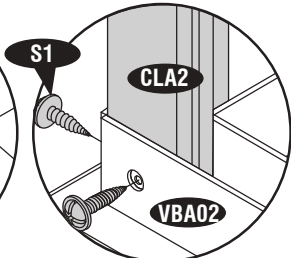

4

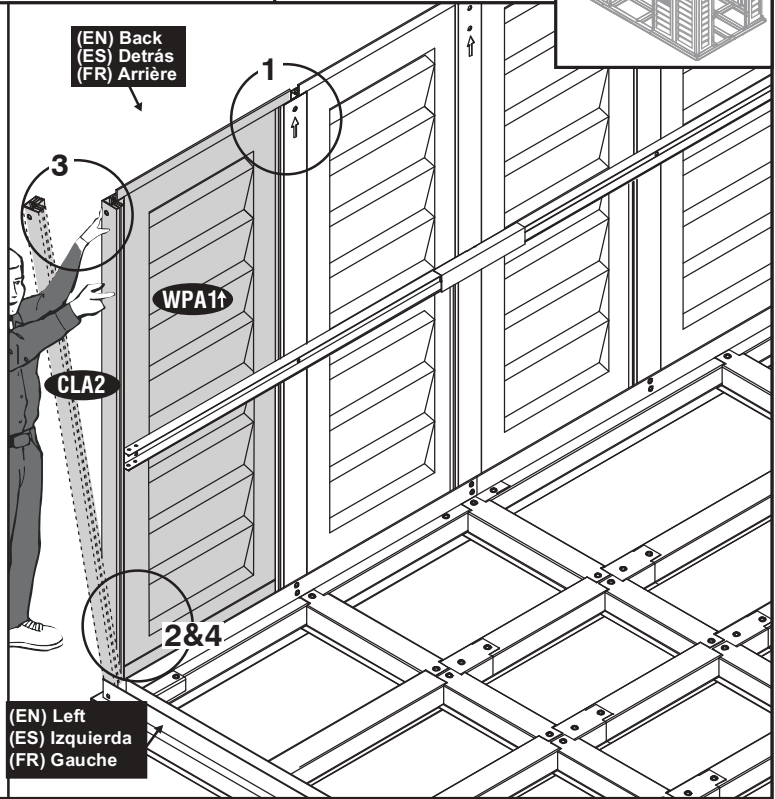

14

FCB(x1)

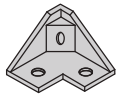

S2 (x1)



S1 (x1)

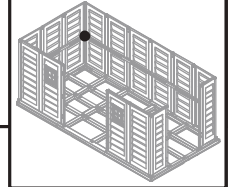

(EN) Needed to hold the panel at this step.  
 (ES) Necesario para sostener el panel en este paso.  
 (FR) Nécessaire pour maintenir le panneau à cette étape.

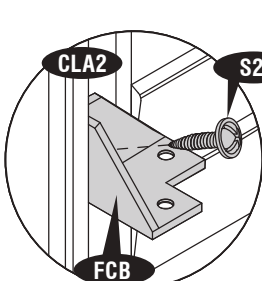

1

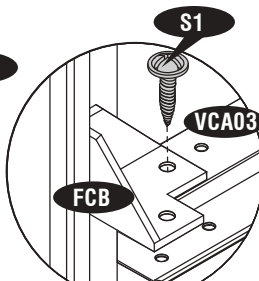

2

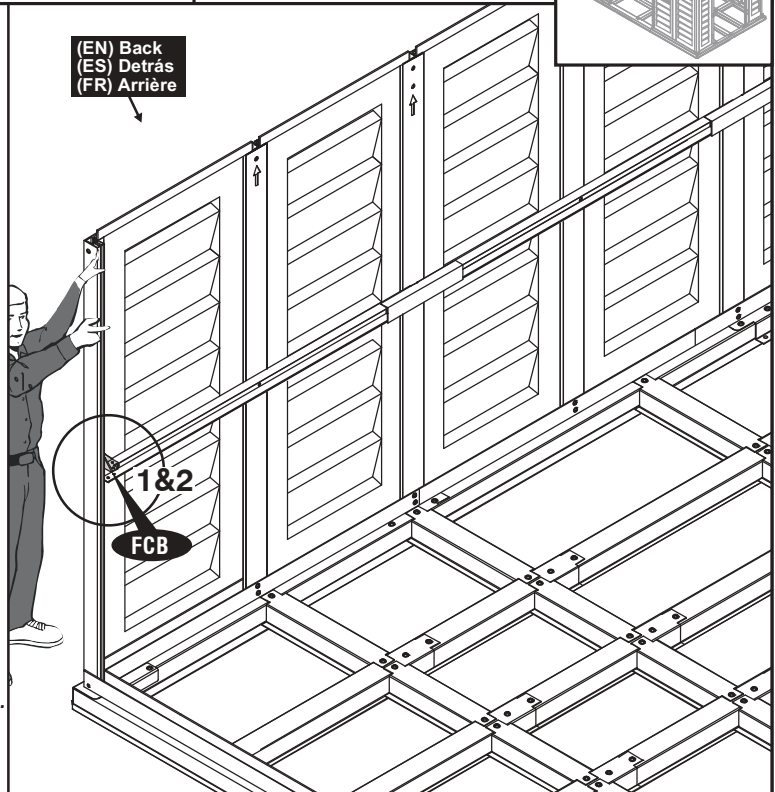

(EN) Do not tighten the (S2) screw. Leave it loose.  
 (ES) No apriete el (S2) tornillo. Déjalo suelto.  
 (FR) Ne pas serrer la (S2) vis. Laissez le lâche.

15

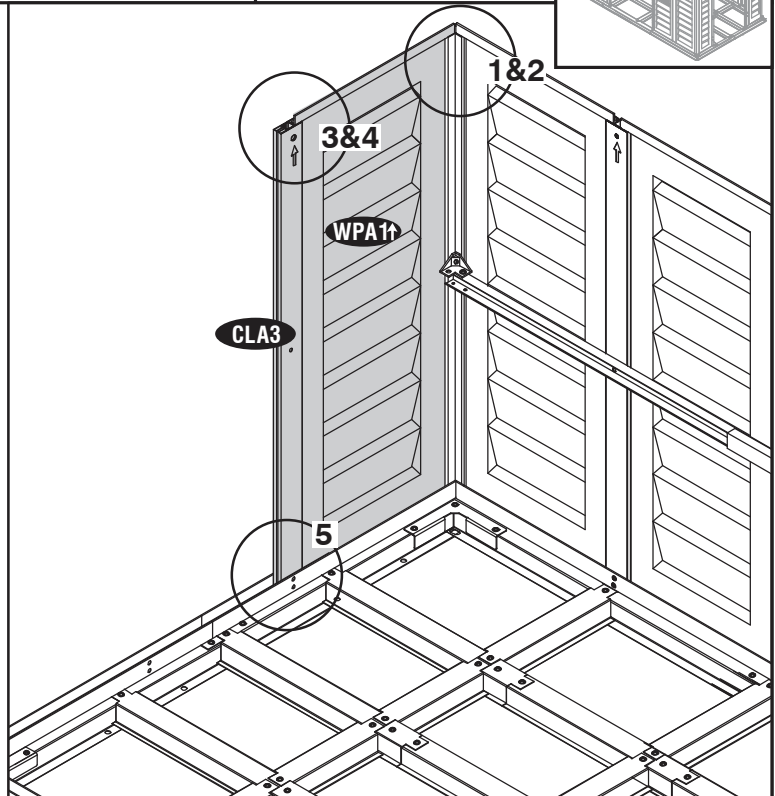
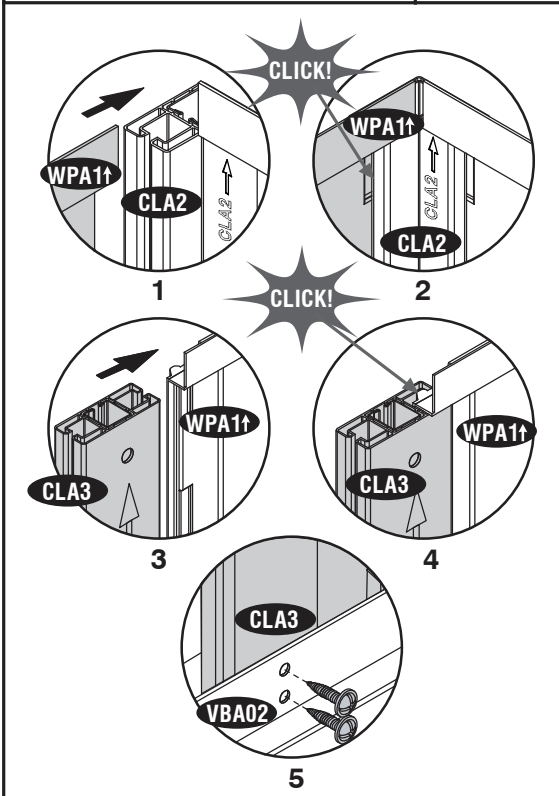
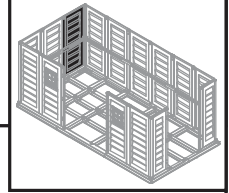
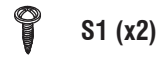
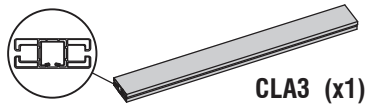

16

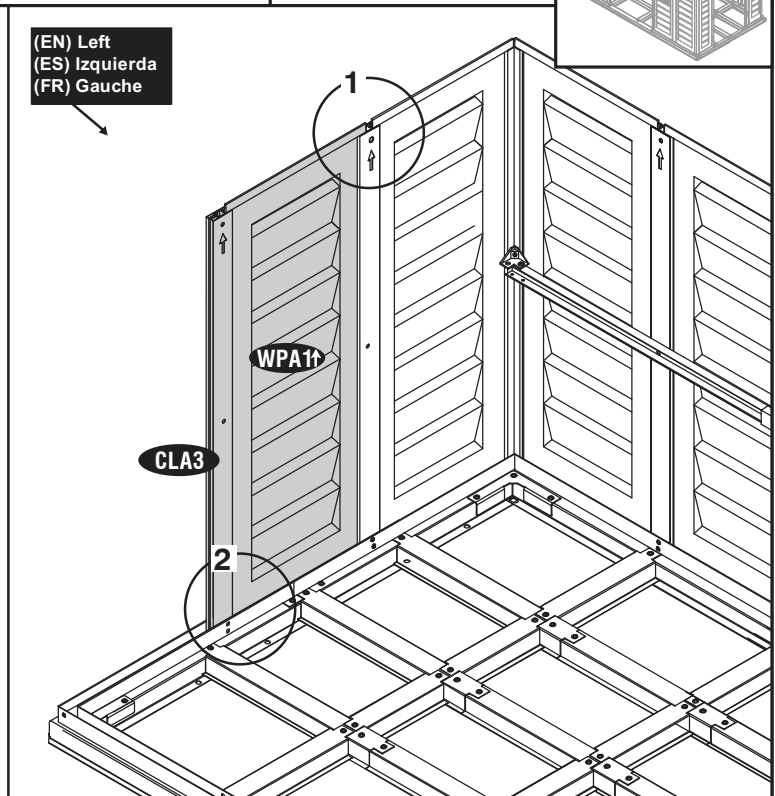
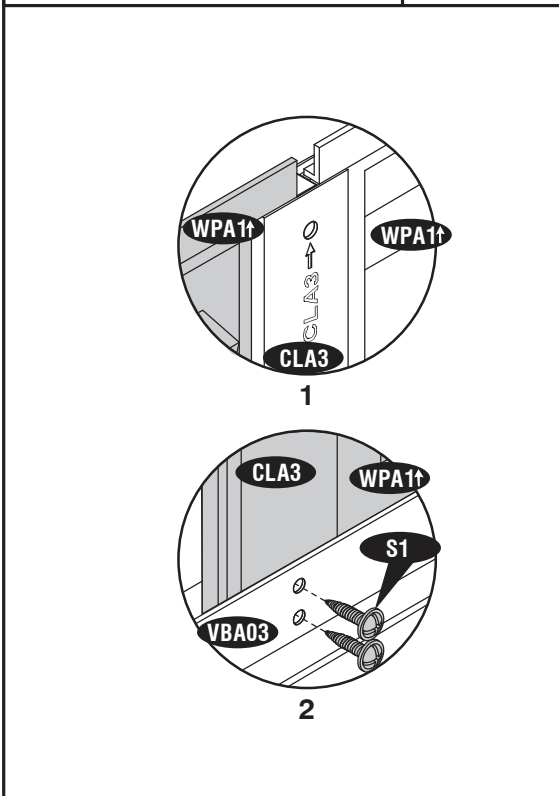
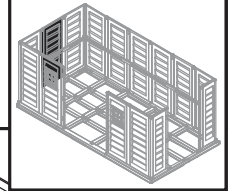
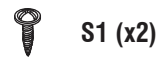
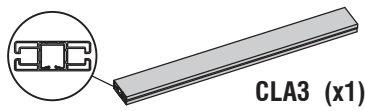

17

C

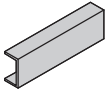

CBC (x1)



S1 (x4)

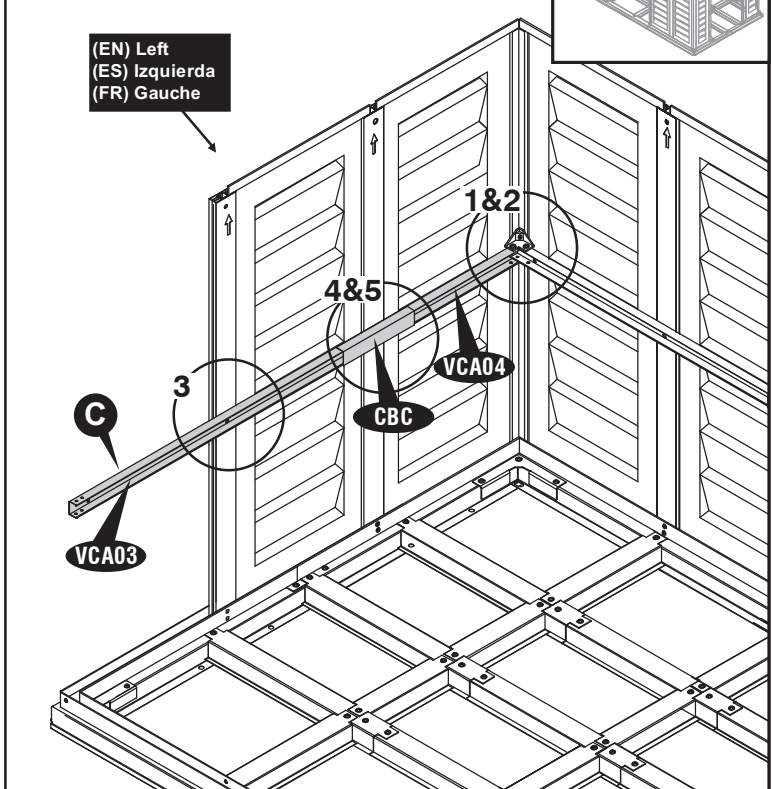
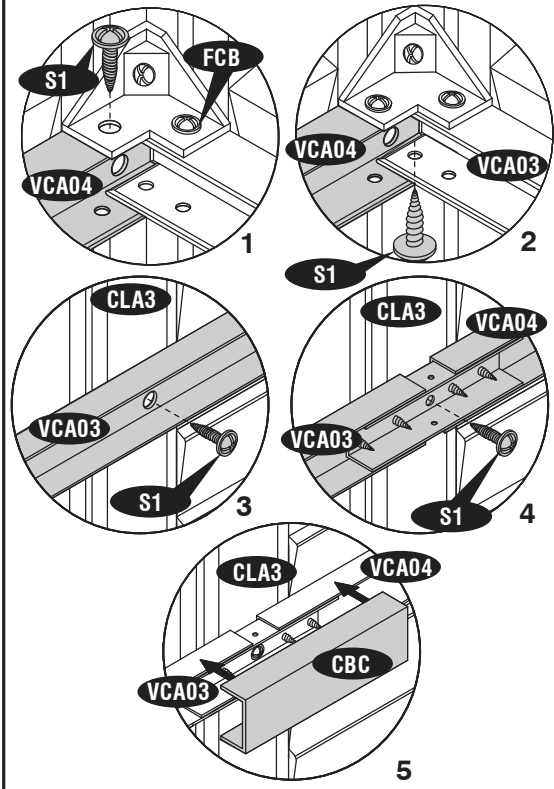
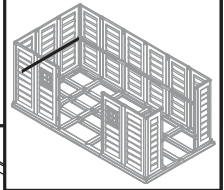

18

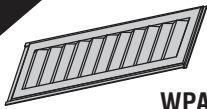

WPA1↑ (x1)

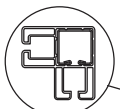

CLA2 (x1)



S1 (x2)

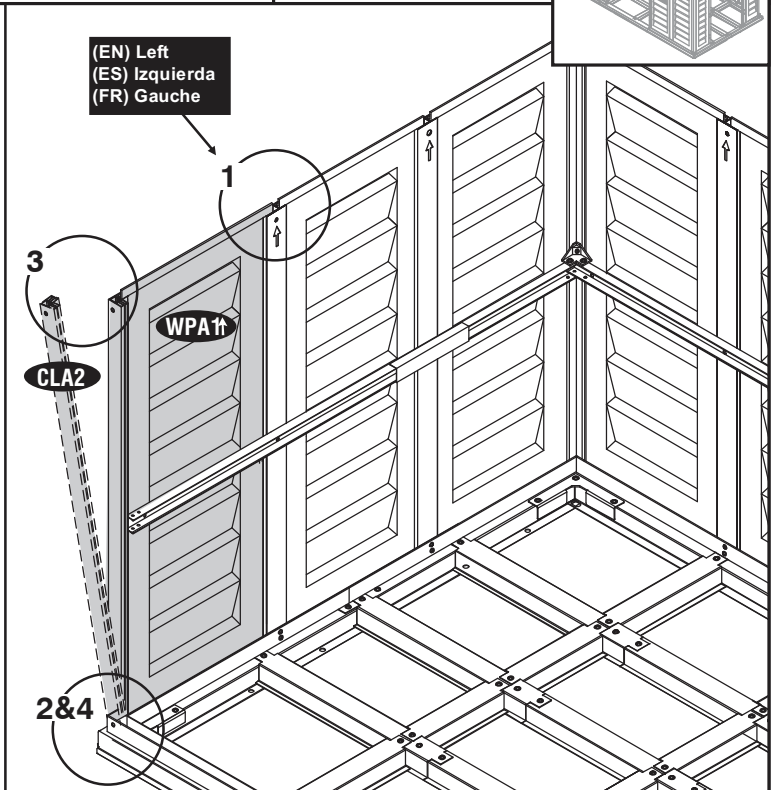
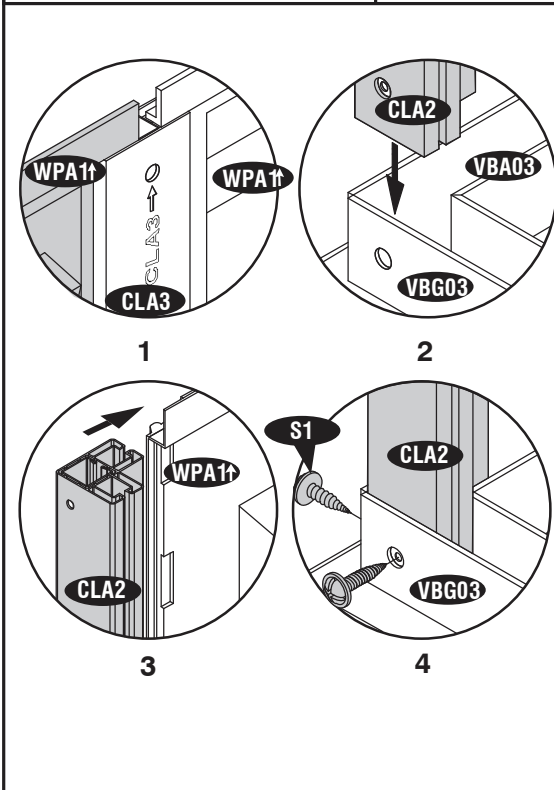
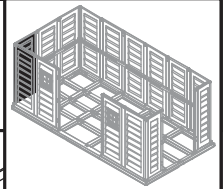

43

(EN) IMPORTANT: USE HAND GLOVES TO PREVENT INJURY.  
(FR) IMPORTANT: UTILISER LES GANTS POUR PREVENIR LES ACCIDENTS.

(ES) IMPORTANTE: GUANTES DE MANO DE USO PARA PREVENIR LA HERIDA.

19

FCB(x1)

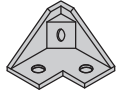

S2 (x1)



S1 (x1)

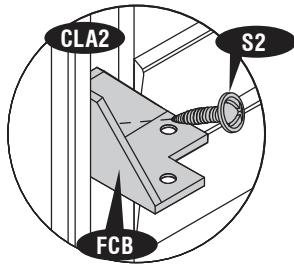
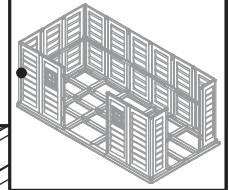

1

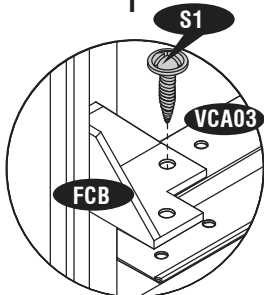

2

(EN) Left  
(ES) Izquierda  
(FR) Gauche



(EN) Do not tighten the (S2) screw. Leave it loose.  
(ES) No apriete el (S2) tornillo. Déjalo suelto.  
(FR) Ne pas serrer la (S2) vis. Laissez le lâche.

20

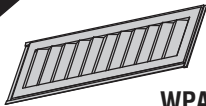

WPA1+ (x1)

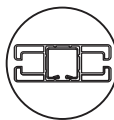

CLA3 (x1)



S1 (x2)

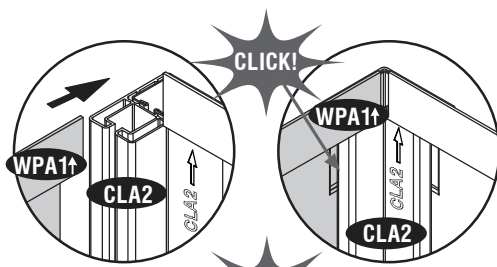
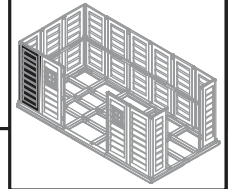

1

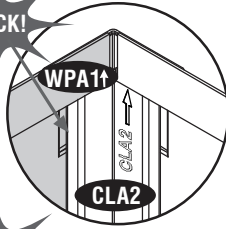

2

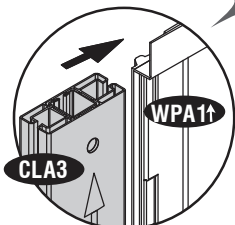

3

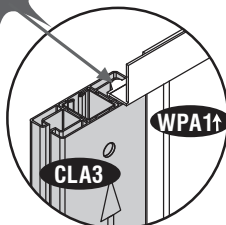

4

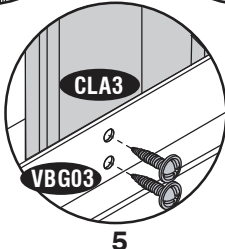

5

(EN) Front  
(ES) Frente  
(FR) Avant

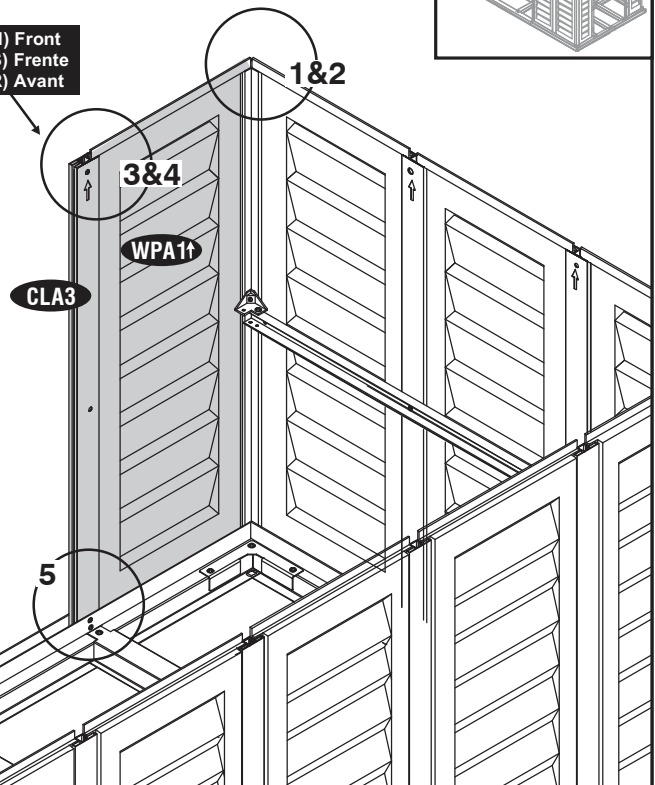

44

(EN) IMPORTANT: USE HAND GLOVES TO PREVENT INJURY.  
(FR) IMPORTANT: UTILISER LES GANTS POUR PREVENIR LES ACCIDENTS.

(ES) IMPORTANTE: GUANTES DE MANO DE USO PARA PREVENIR LA HERIDA.

21

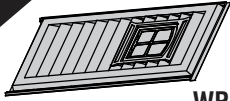

WPA2t (x1)

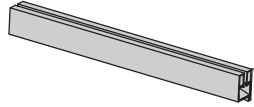

CLG2 (x1)



S1 (x2)

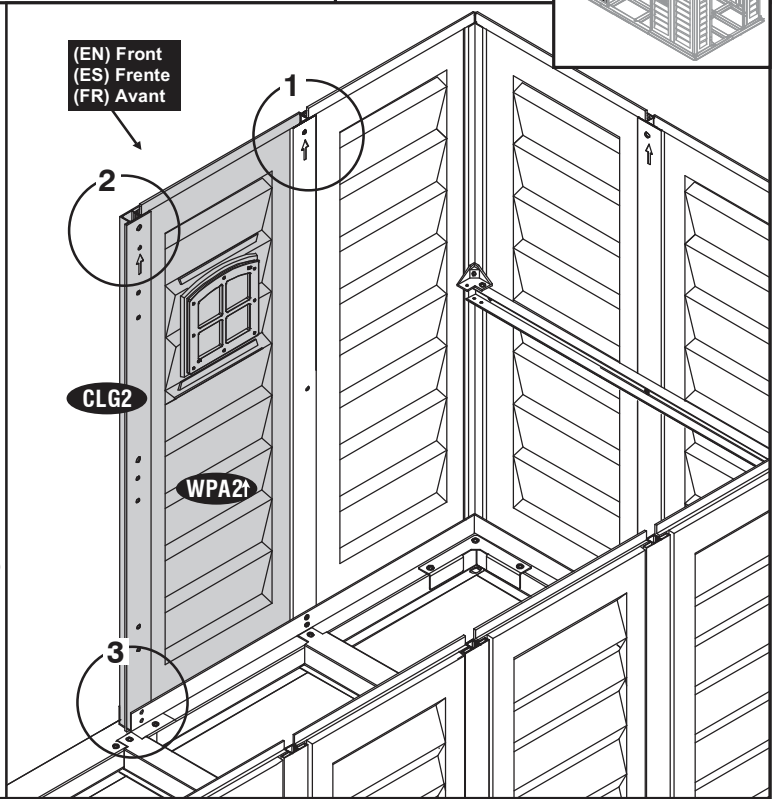
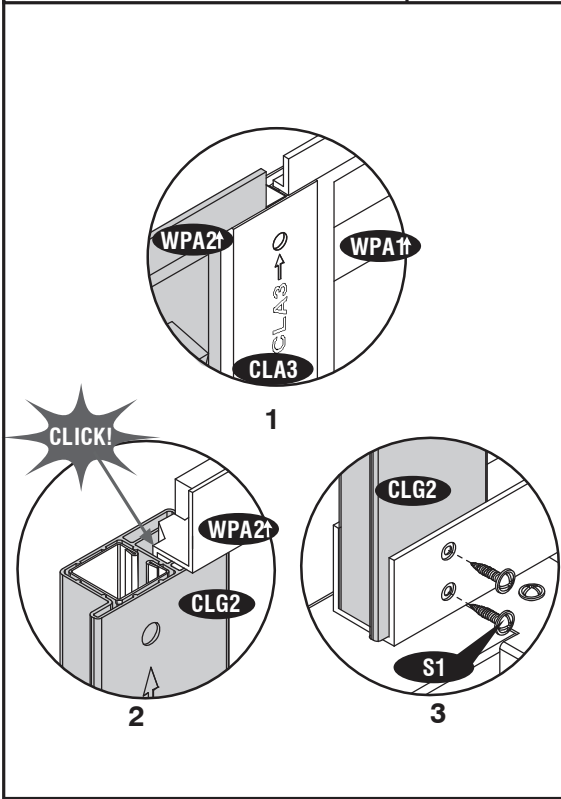
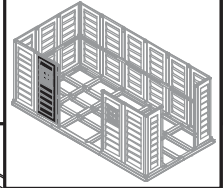

22

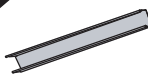

VCG03 (x1)



EPS (x1)



S1 (x4)

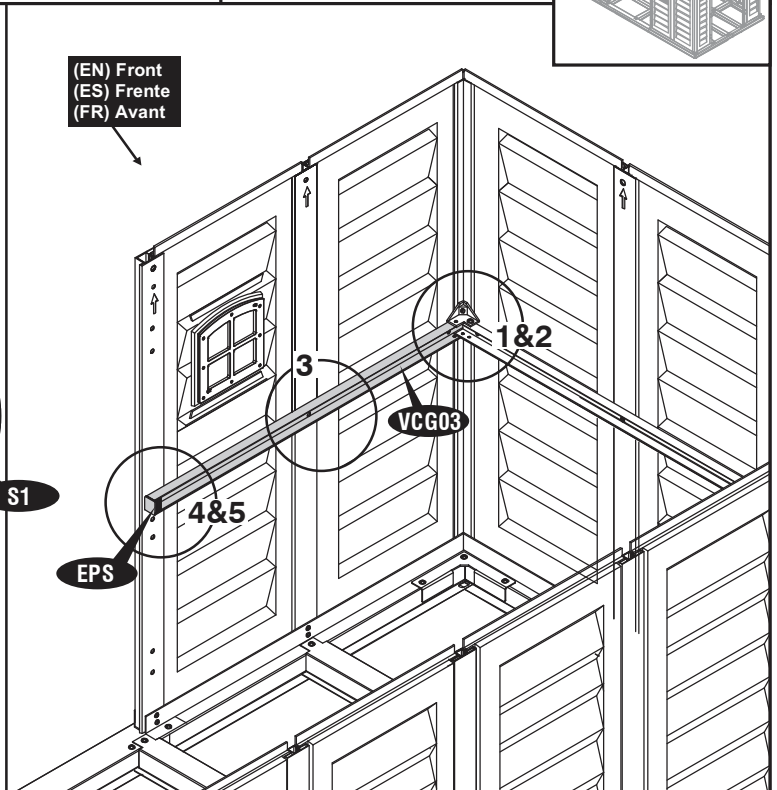
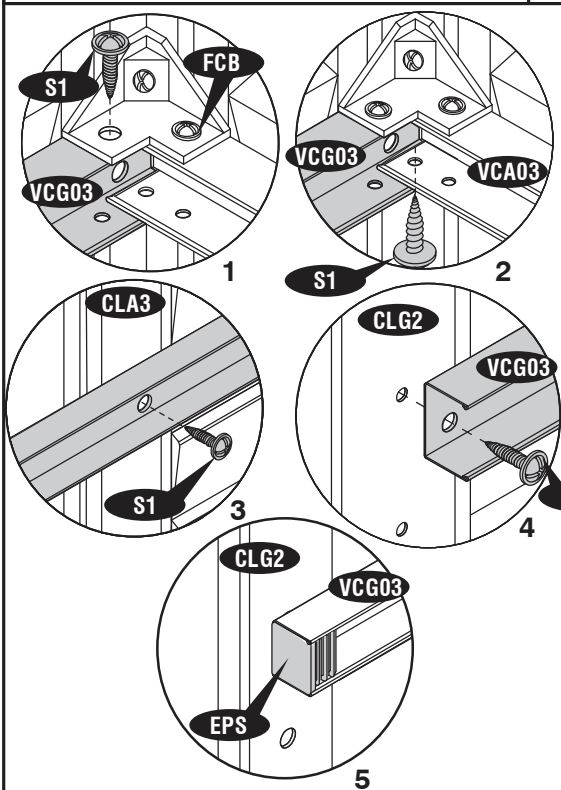
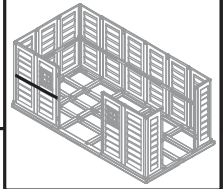

45

(EN) IMPORTANT: USE HAND GLOVES TO PREVENT INJURY.  
(FR) IMPORTANT: UTILISER LES GANTS POUR PREVENIR LES ACCIDENTS.

(ES) IMPORTANTE: GUANTES DE MANO DE USO PARA PREVENIR LA HERIDA.

23

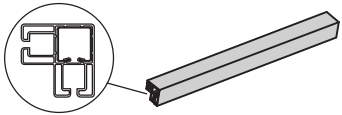

CLA2 (x1)



S1 (x2)

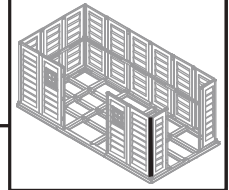

(EN) Make sure that, the arrow mark points up.  
 (ES) Asegúrese de, marca de la flecha apunte hacia arriba.  
 (FR) Assurez-vous que la flèche pointe vers le haut.

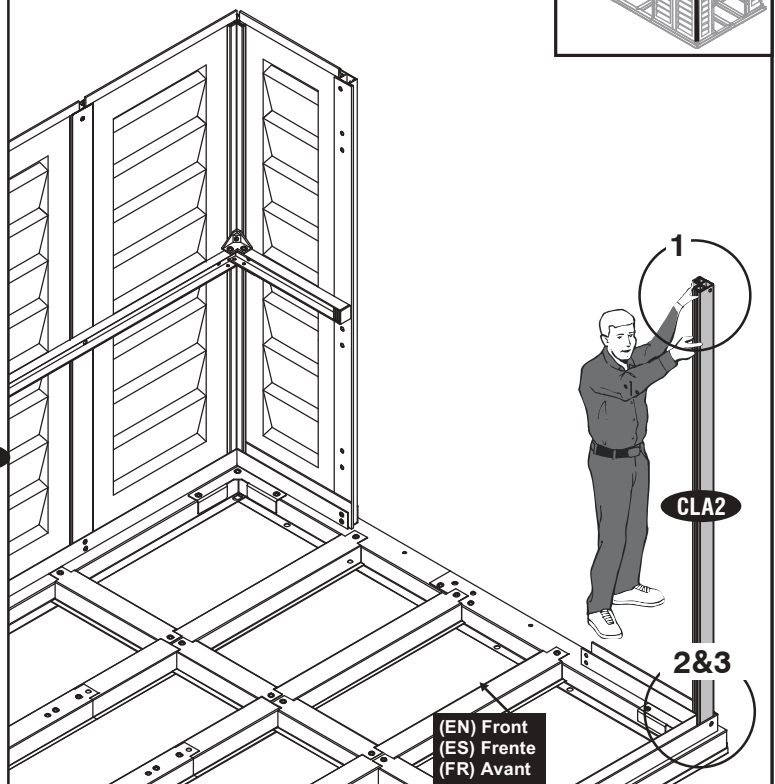
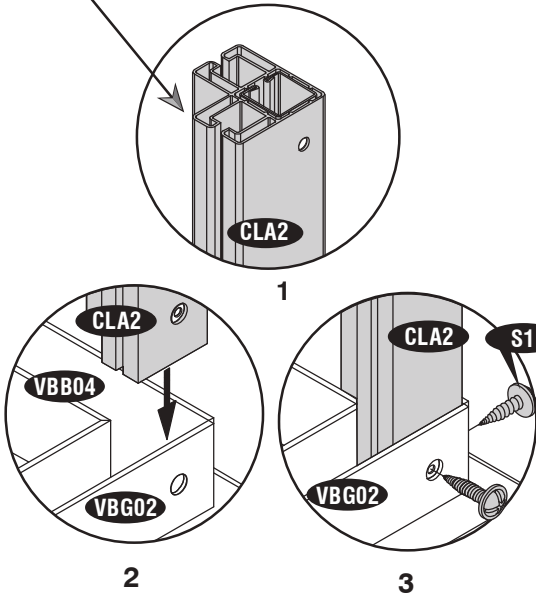

24

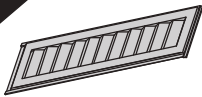

WPB1t (x1)

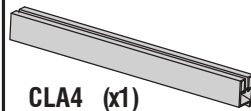

CLA4 (x1)



S1 (x2)

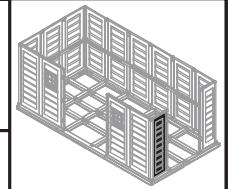

(EN) Needed to hold the panel at this step.  
 (ES) Necesario para sostener el panel en este paso.  
 (FR) Nécessaire pour maintenir le panneau à cette étape.

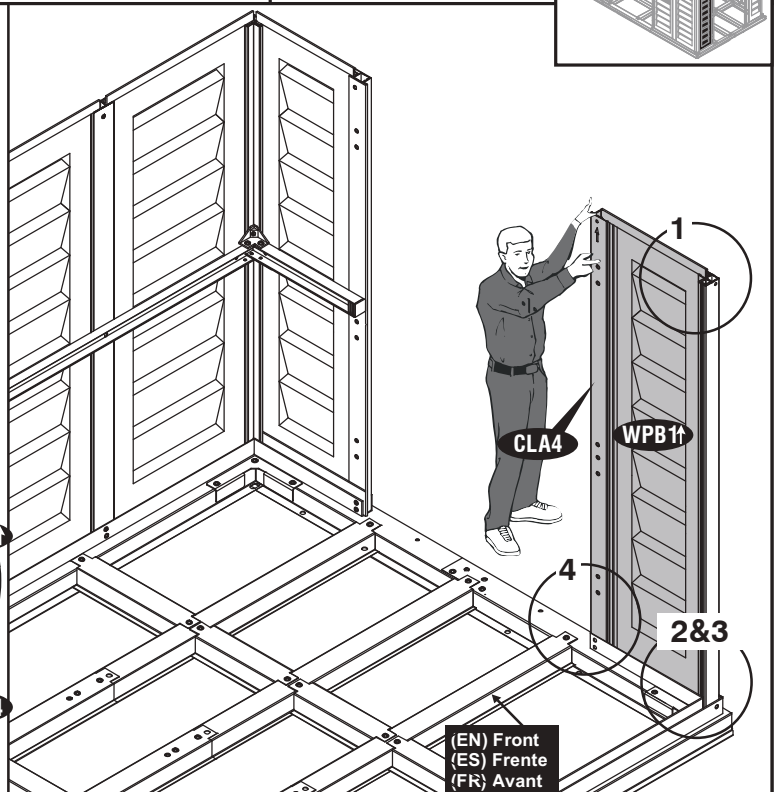
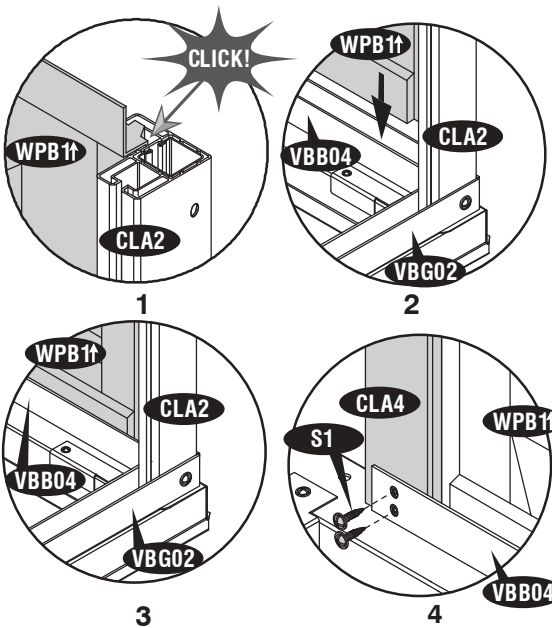

46

(EN) IMPORTANT: USE HAND GLOVES TO PREVENT INJURY.  
 (FR) IMPORTANT: UTILISER LES GANTS POUR PREVENIR LES ACCIDENTS.

(ES) IMPORTANTE: GUANTES DE MANO DE USO PARA PREVENIR LA HERIDA.



25

FCB(x1)

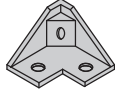

S2 (x1)

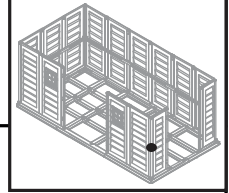

(EN) Needed to hold the panel at this step.  
 (ES) Necesario para sostener el panel en este paso.  
 (FR) Nécessaire pour maintenir le panneau à cette étape.

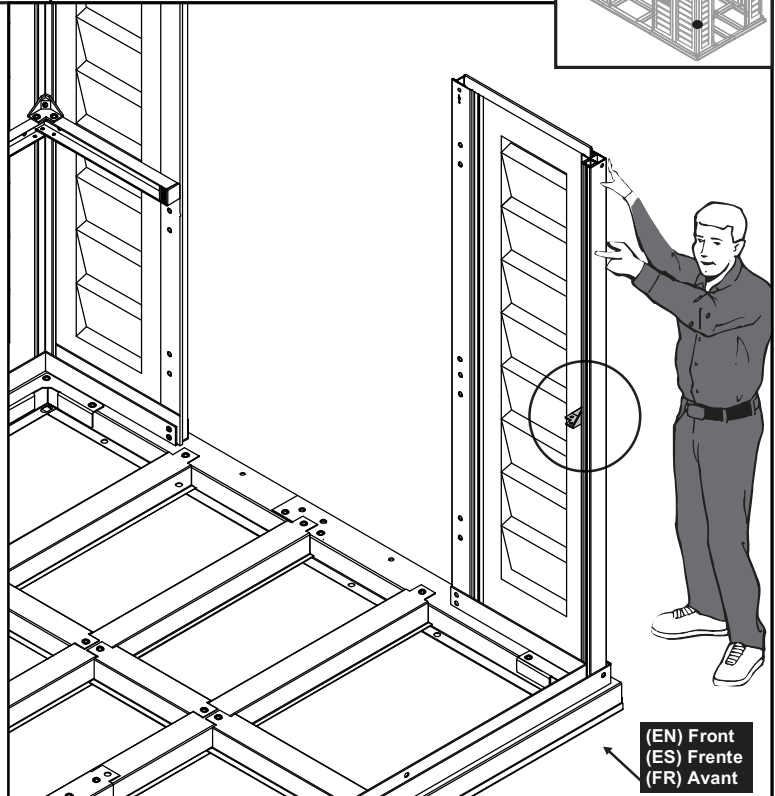
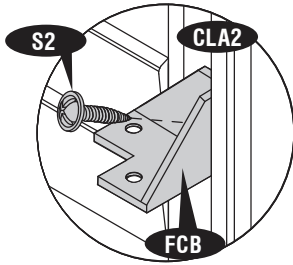

(EN) Front  
 (ES) Frente  
 (FR) Avant

26

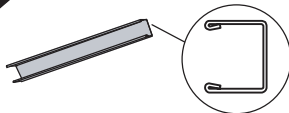

VCG01 (x1)



S1 (x2)

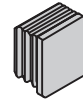

EPS (x1)

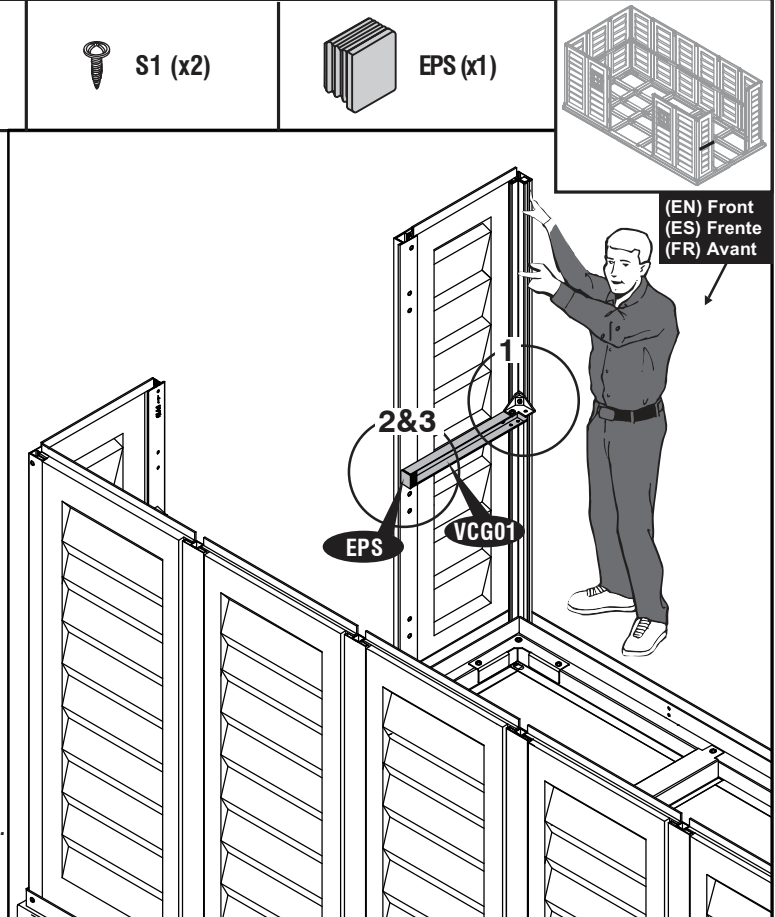
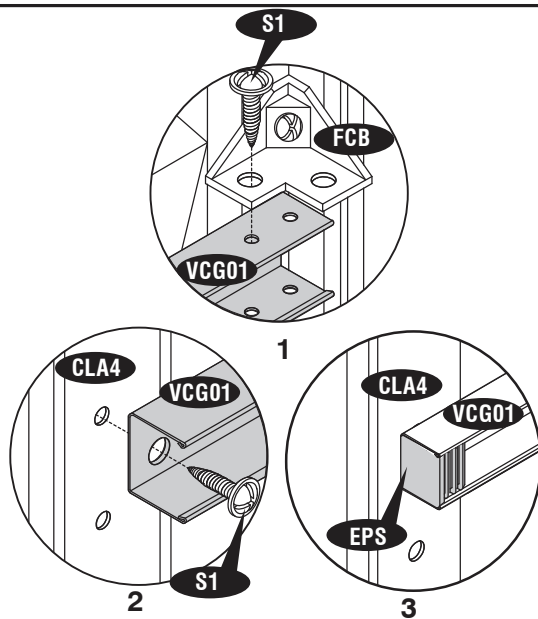
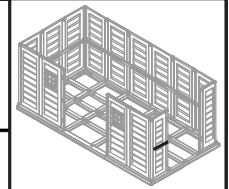

(EN) Front  
 (ES) Frente  
 (FR) Avant



(EN) Do not tighten the (S2) screw. Leave it loose.  
 (ES) No apriete el (S2) tornillo. Déjalo suelto.  
 (FR) Ne pas serrer la (S2) vis. Laissez le lâche.

47

(EN) IMPORTANT: USE HAND GLOVES TO PREVENT INJURY.  
 (FR) IMPORTANT: UTILISER LES GANTS POUR PREVENIR LES ACCIDENTS.

(ES) IMPORTANTE: GUANTES DE MANO DE USO PARA PREVENIR LA HERIDA.

27



WPA1↑ (x1)



CLA3 (x1)



S1 (x2)

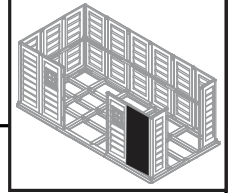

(EN) Needed to hold the panel at this step.  
 (ES) Necesario para sostener el panel en este paso.  
 (FR) Nécessaire pour maintenir le panneau à cette étape.

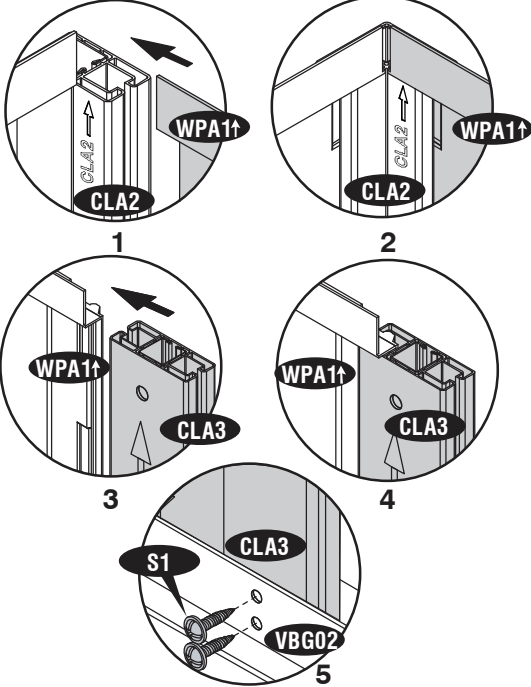

(EN) Right  
 (FR) Partie droite  
 (ES) Correcta

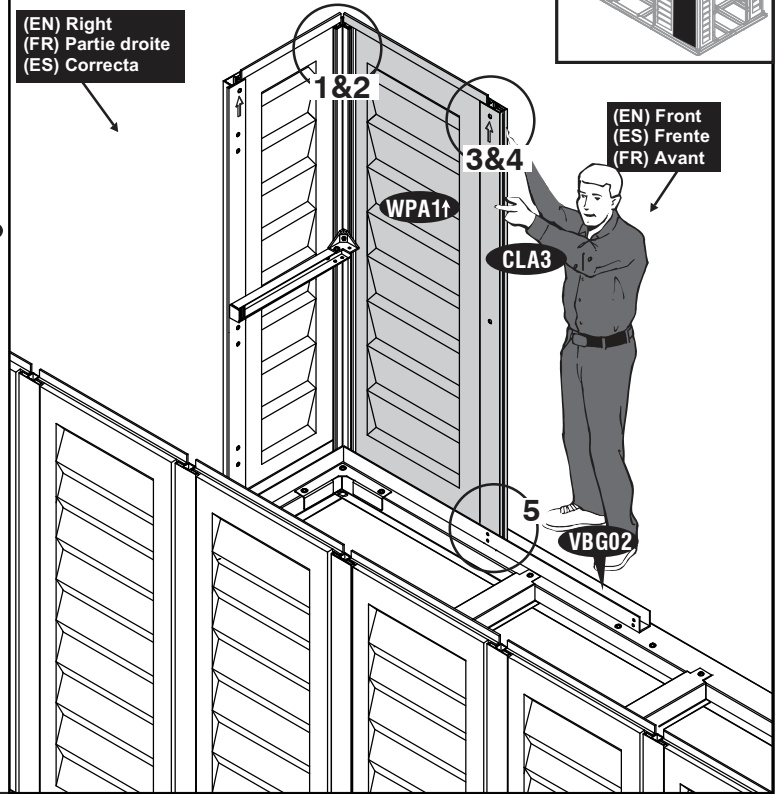

28

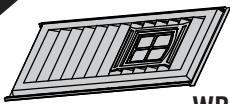

WPA2↑ (x1)



CLG1 (x1)



S1 (x2)

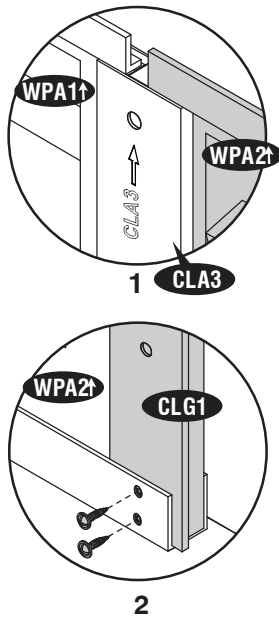
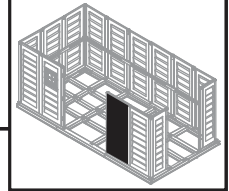

(EN) Front  
 (ES) Frente  
 (FR) Avant

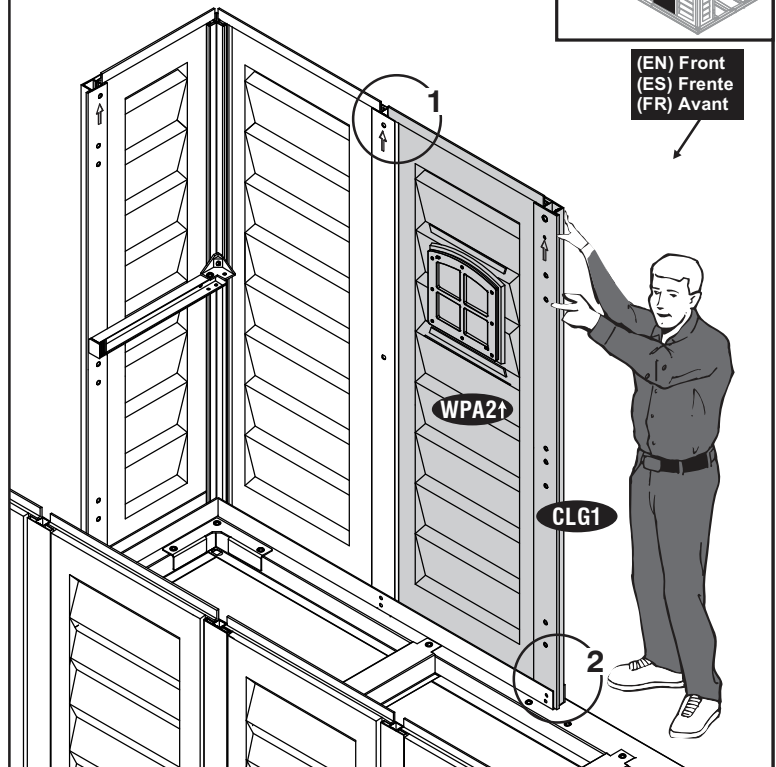

48

(EN) IMPORTANT: USE HAND GLOVES TO PREVENT INJURY.  
 (FR) IMPORTANT: UTILISER LES GANTS POUR PREVENIR LES ACCIDENTS.

(ES) IMPORTANTE: GUANTES DE MANO DE USO PARA PREVENIR LA HERIDA.

29

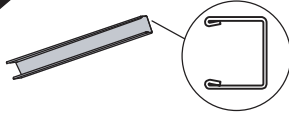

VCG03 (x1)

S1 (x4)

EPS (x1)

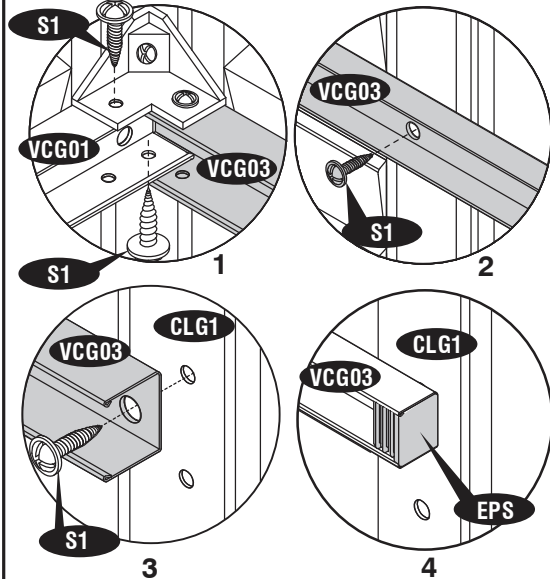
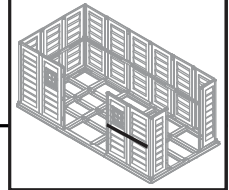

**3** (EN) After completing the center band assembly, fully tighten the four center band fittings (FCB) to the corner column (CLA2).  
 (ES) Después de completar el montaje de la banda central, apretar la instalación de tres bandas del centro (FCB) a las columnas de esquina (CLA2).  
 (FR) Après avoir complété l'assemblage de la bande centre, resserrer complètement les quatre bandes centre ajustables (FCB) à la colonne d'angle (CLA2).

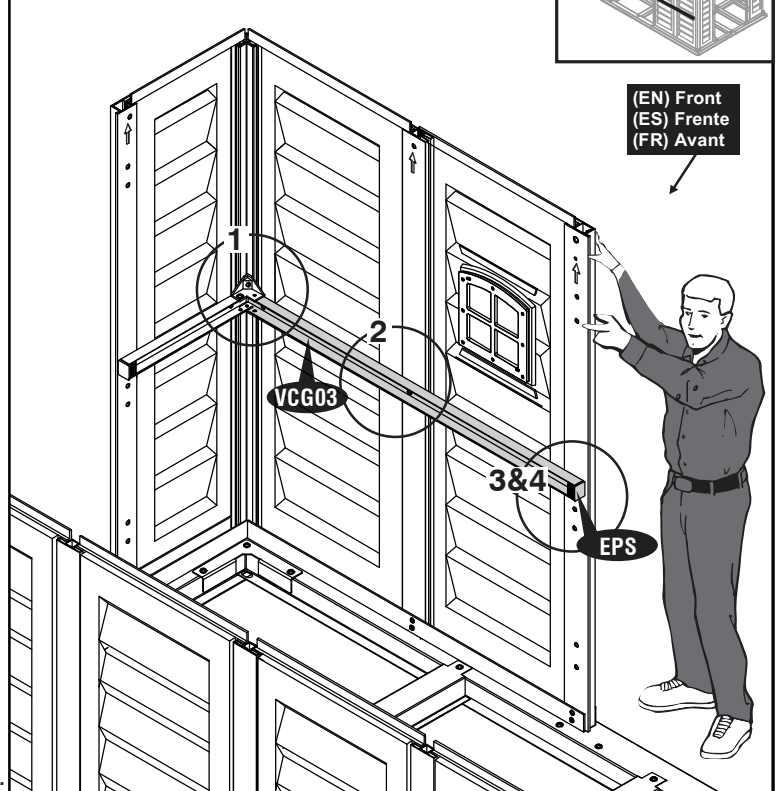

(EN) Front  
 (ES) Frente  
 (FR) Avant

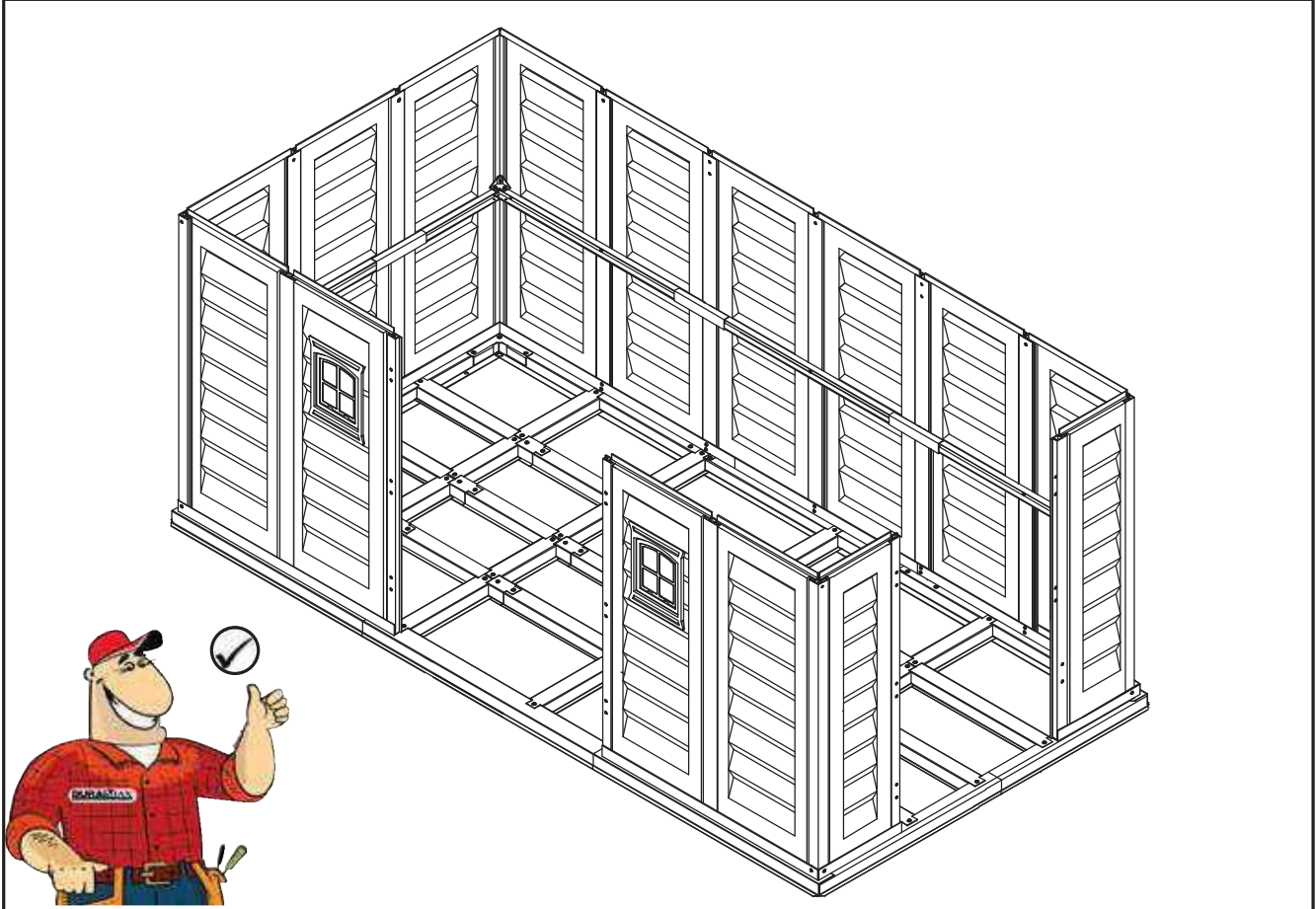

49

(EN) IMPORTANT: USE HAND GLOVES TO PREVENT INJURY.  
 (FR) IMPORTANT: UTILISER LES GANTS POUR PREVENIR LES ACCIDENTS.  
 (ES) IMPORTANTE: GUANTES DE MANO DE USO PARA PREVENIR LA HERIDA.



5

(EN) Roof Structures  
(ES) Estructuras de techo  
(FR) Charpente



(EN) Parts needed  
(ES) Las partes necesitaron  
(FR) Pièces nécessaires

(EN)CODE (ES)CODE (FR)CODE	(EN)QTY (ES)QTY (FR)QTÉ	(EN)CODE (ES)CODE (FR)CODE	(EN)QTY (ES)QTY (FR)QTÉ	(EN)CODE (ES)CODE (FR)CODE	(EN)QTY (ES)QTY (FR)QTÉ
D	1	VRG17	1	S1	109
E	1	VRG18	1	S2	4
F	1	VRG19	1	S7	118
G	1	VRG20	5	SG1	4
H	1	VRG21	2		
I	1	VRG22	2		
J	1	VRG23	10		
K	1	VRG24	2		
L	1	FPG1	1		
M	2	FDCL	2		
VRB11	2	FDCR	2		
VRB12	2	FCC	4		
VRG14	1	FMC	9		
VRG16	1	FP	4		

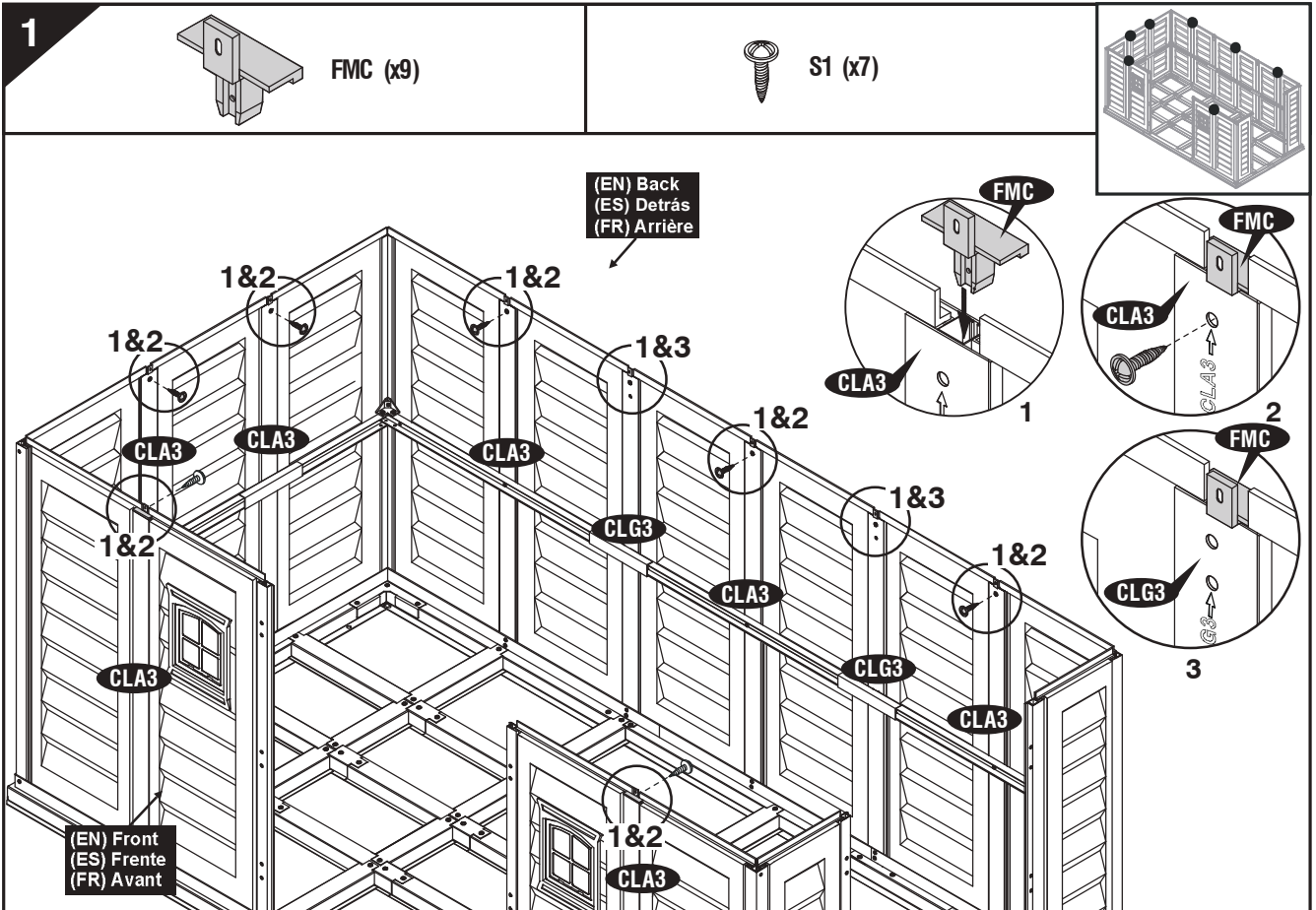

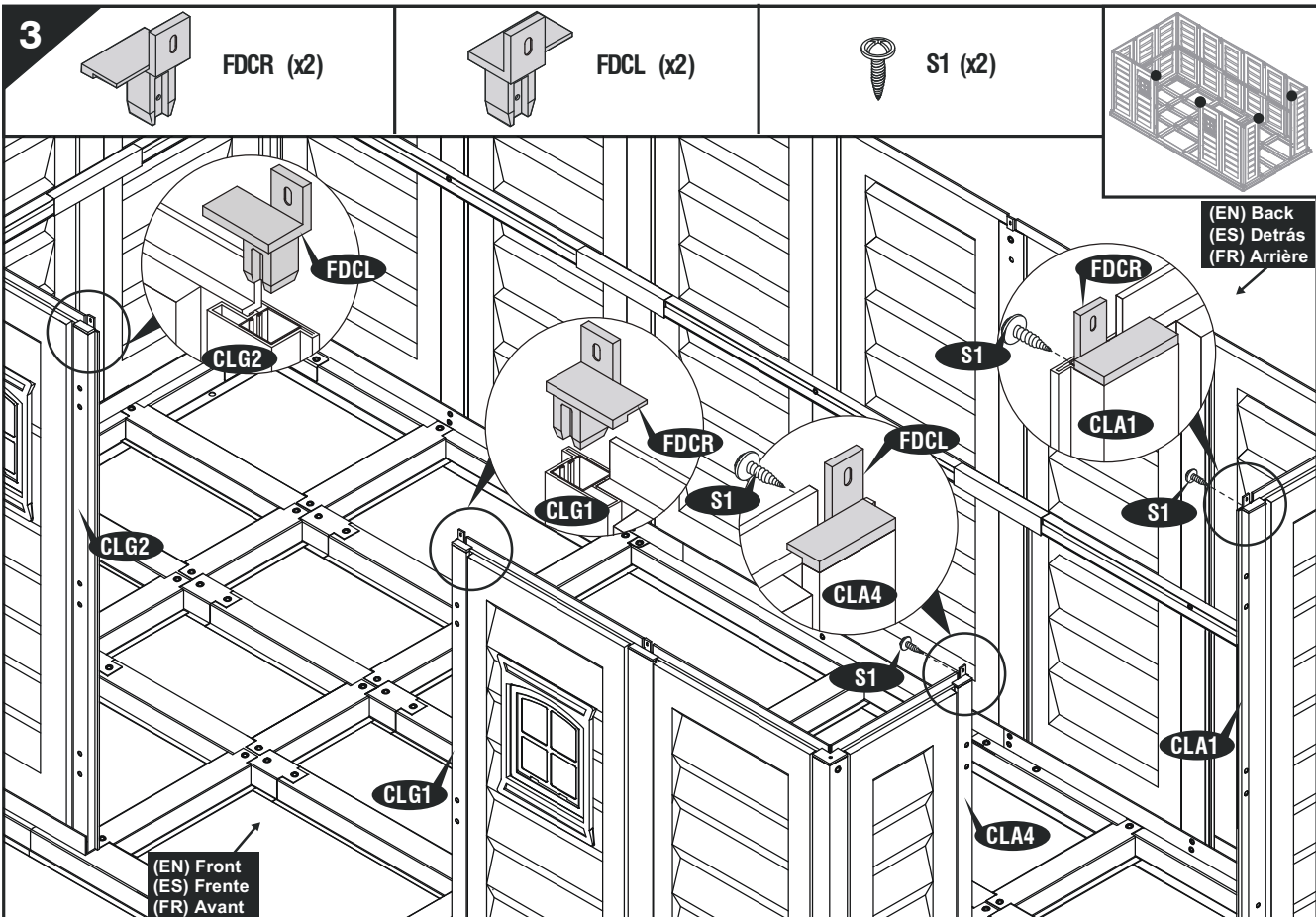
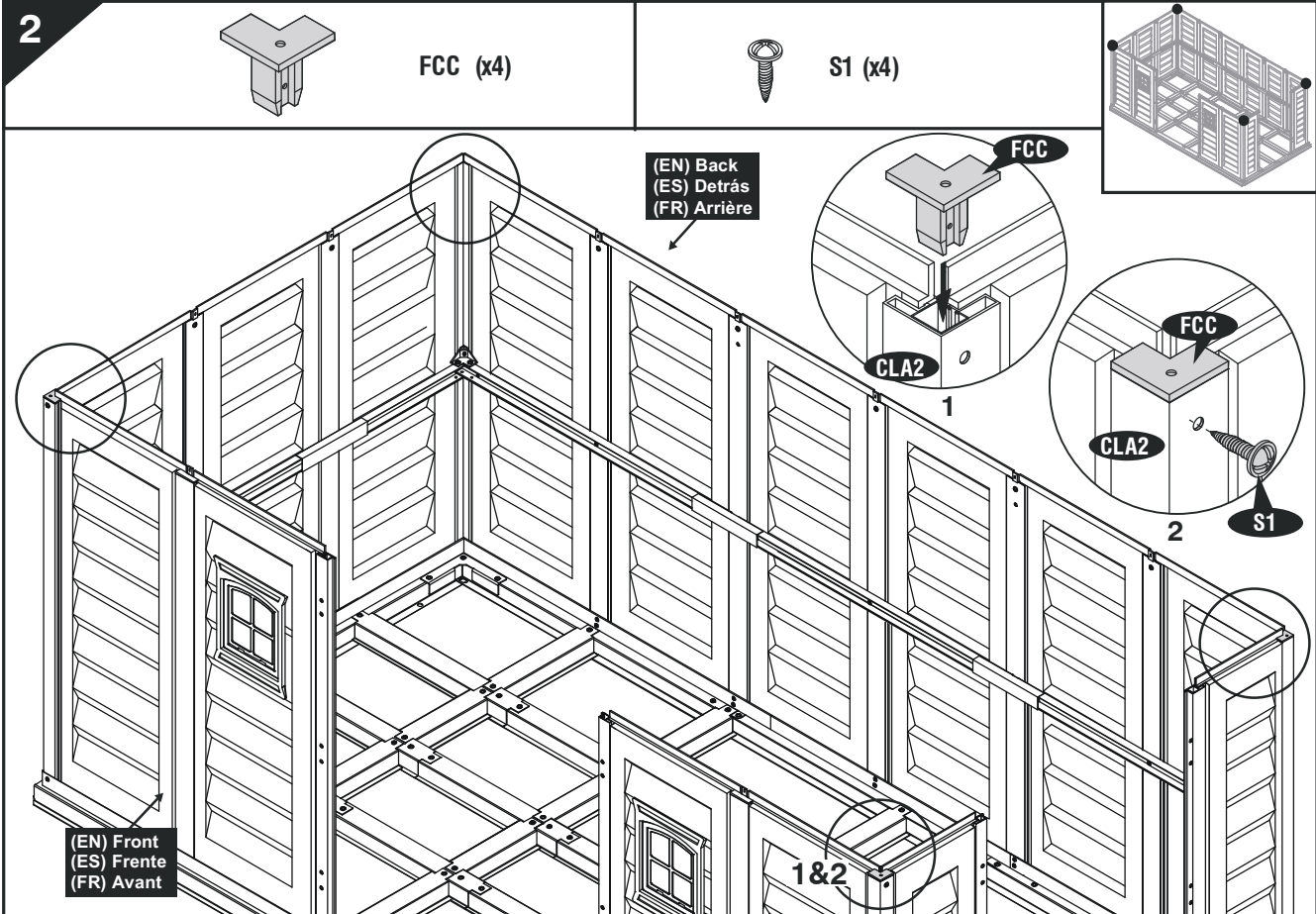

**4**

**D**

S1 (x2)

S2 (x2)

1

2

3

4

FMC

RJ

S1

S2

S2

S1

1,2&4

(EN) Front  
(ES) Frente  
(FR) Avant

**5**

**E**

S1 (x2)

S2 (x2)

1

2

3

4

FDCR

CLA1

S1

S2

S2

S1

1&4

CLA1

CLA4

2,3

(EN) Back  
(ES) Detrás  
(FR) Arrière

6

F

S1 (x2)

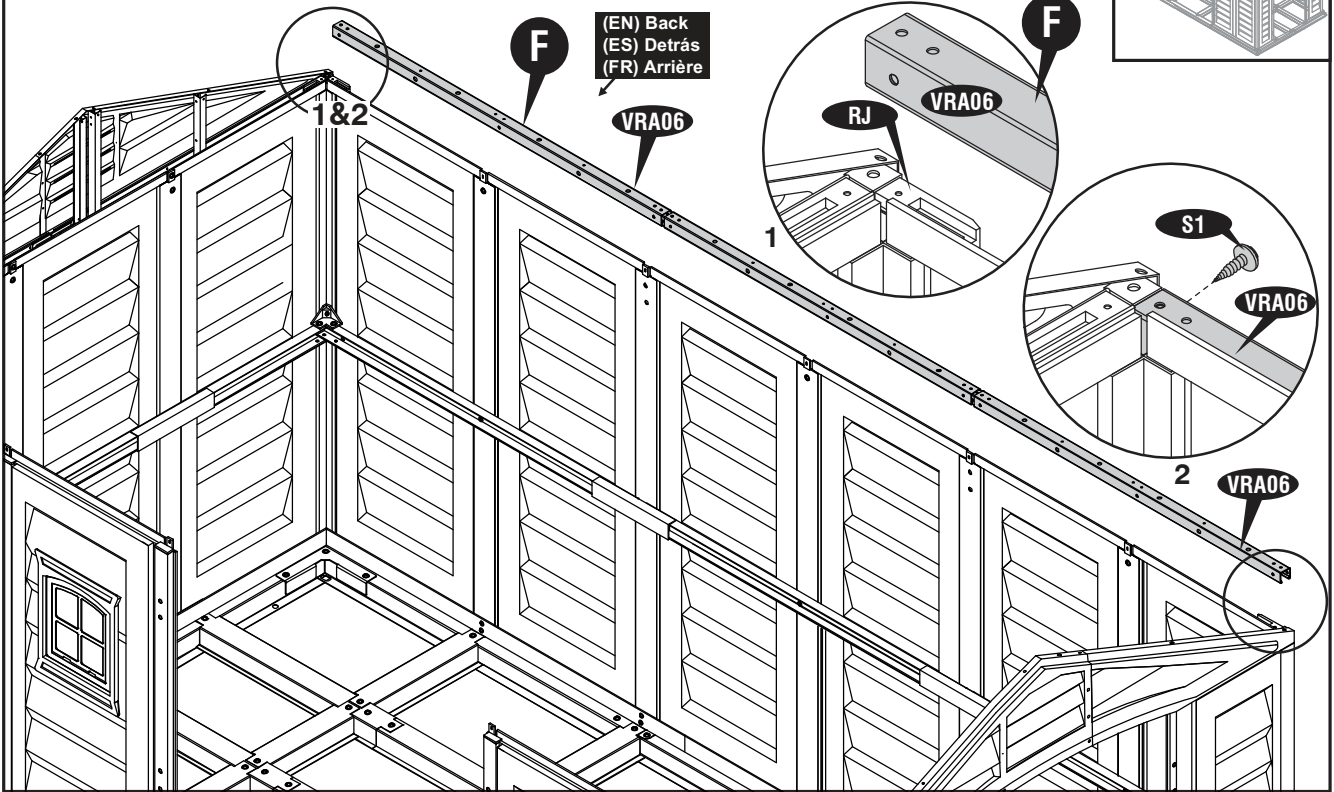
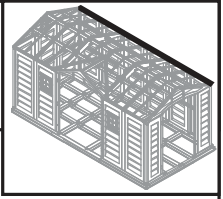

7

S1 (3)

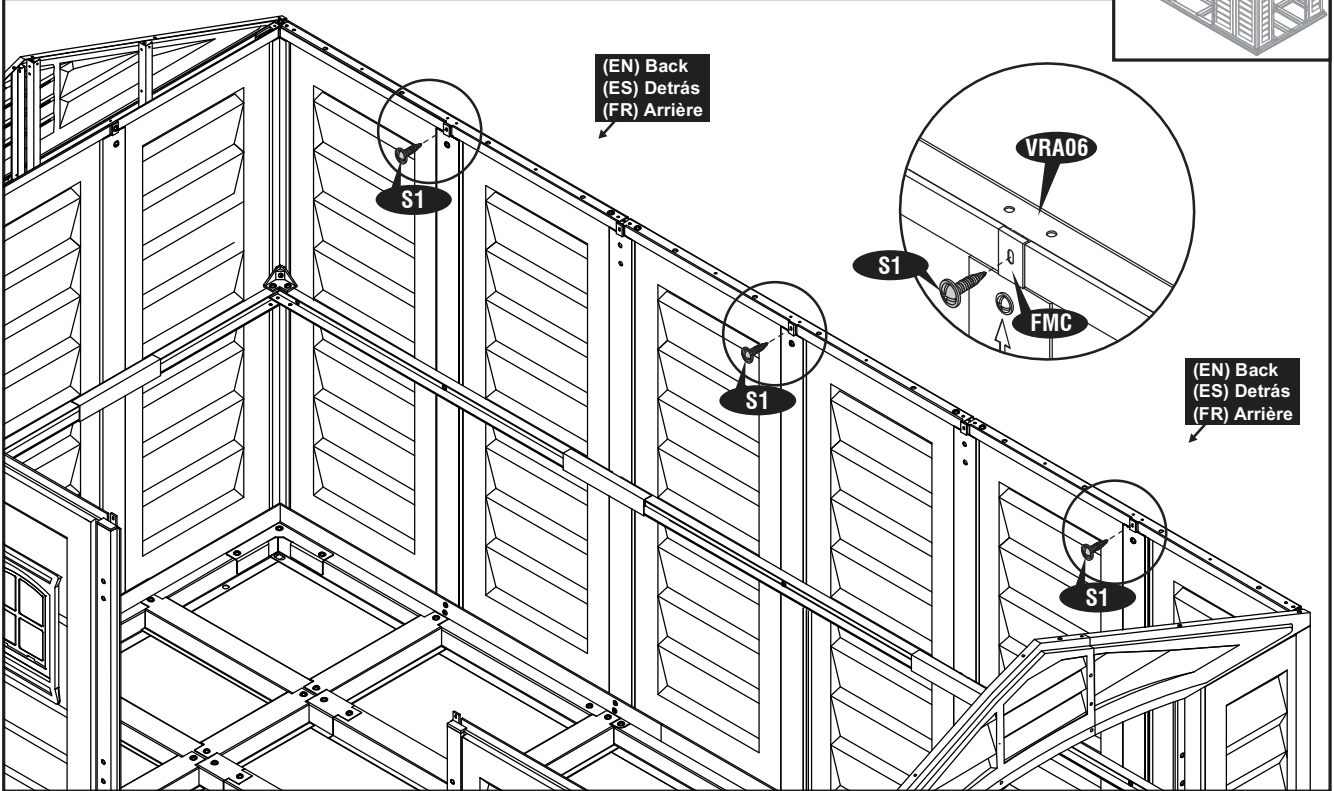
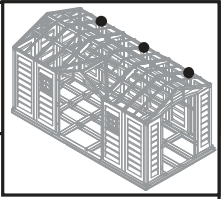

53

8

G

S1 (x2)

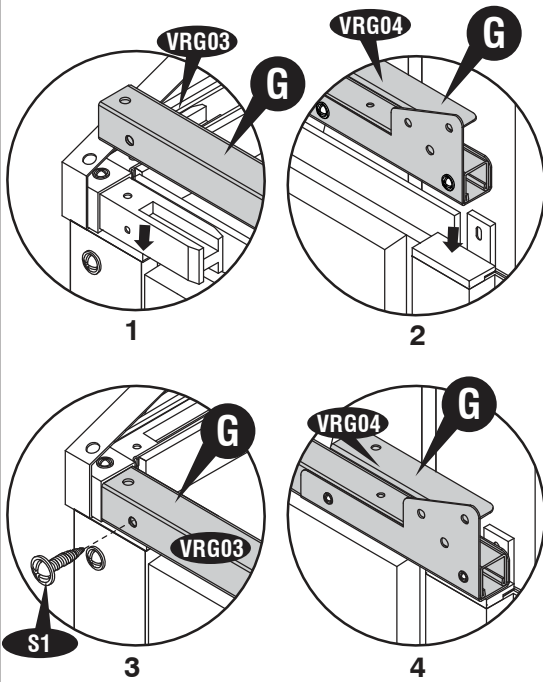
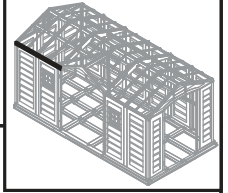

(EN) Left  
(ES) Izquierda  
(FR) Gauche

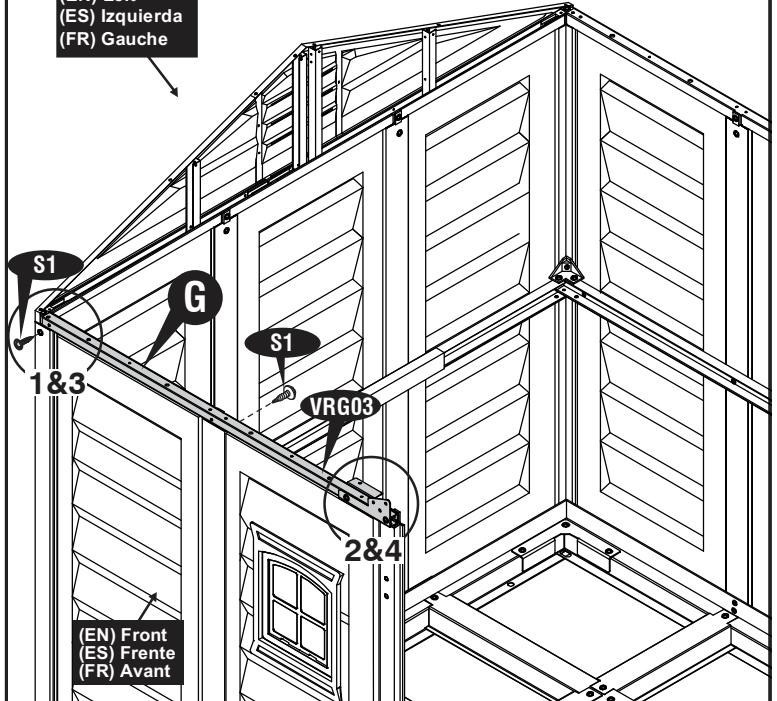

(EN) Front  
(ES) Frente  
(FR) Avant

9

H

S1 (x2)

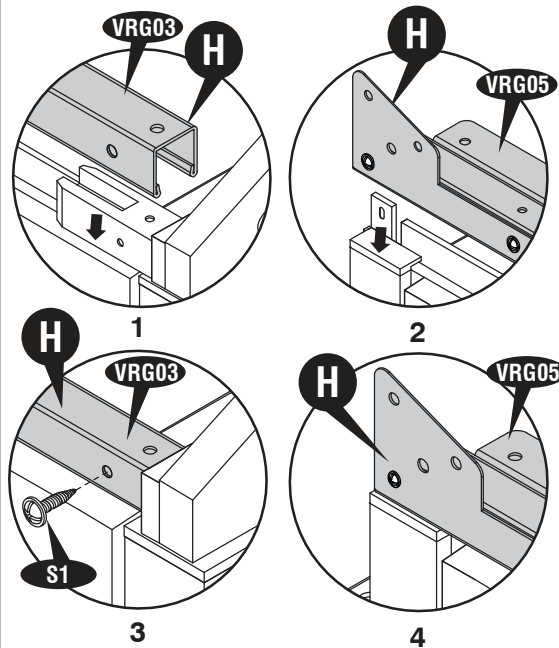
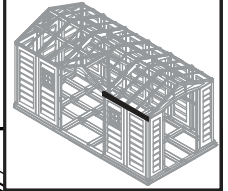

2&4

H

S1

VRG03

S1

1&3

(EN) Front  
(ES) Frente  
(FR) Avant

(EN) Right  
(FR) Partie droite  
(ES) Correcta



10



S1 (x8)

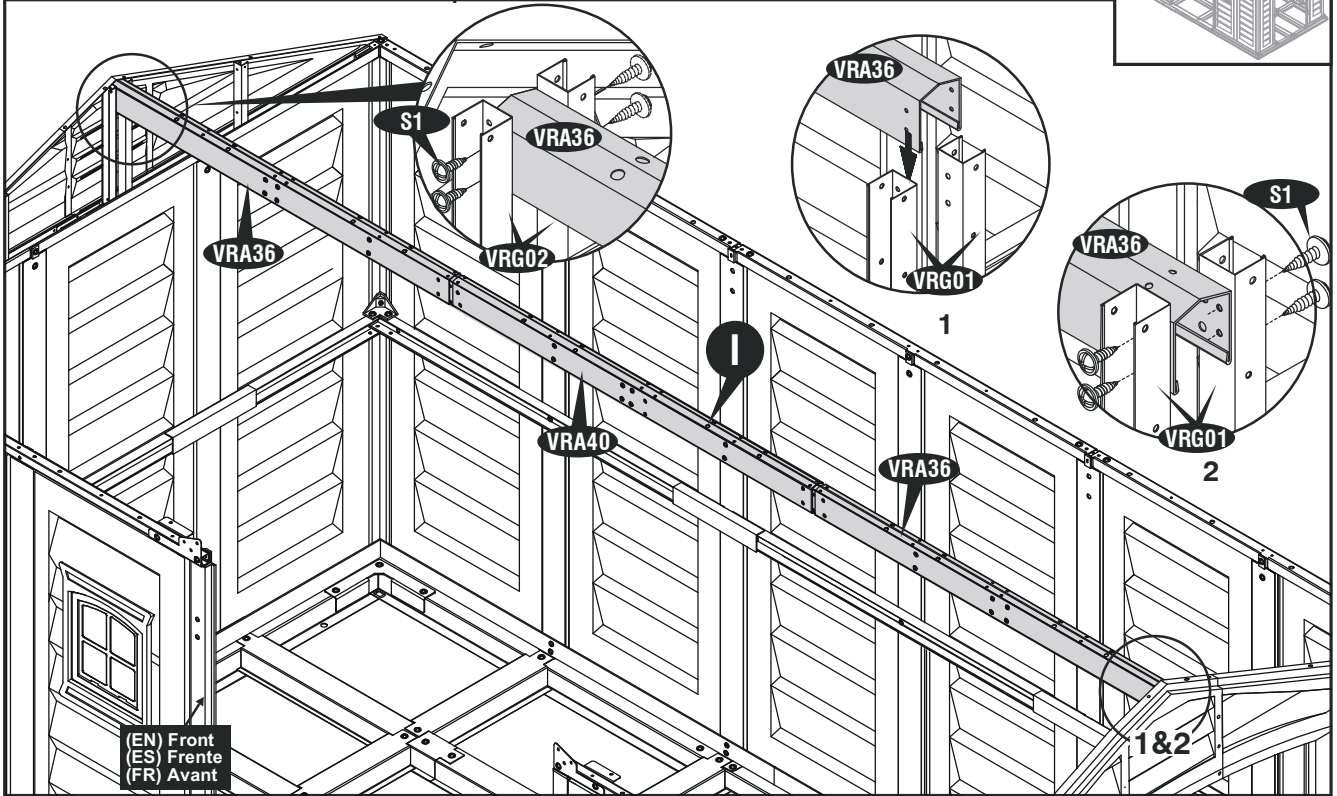
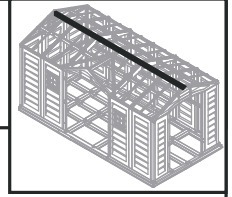

11

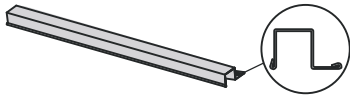

VRB11 (x1)  
VRB12 (x1)

S1 (x12)

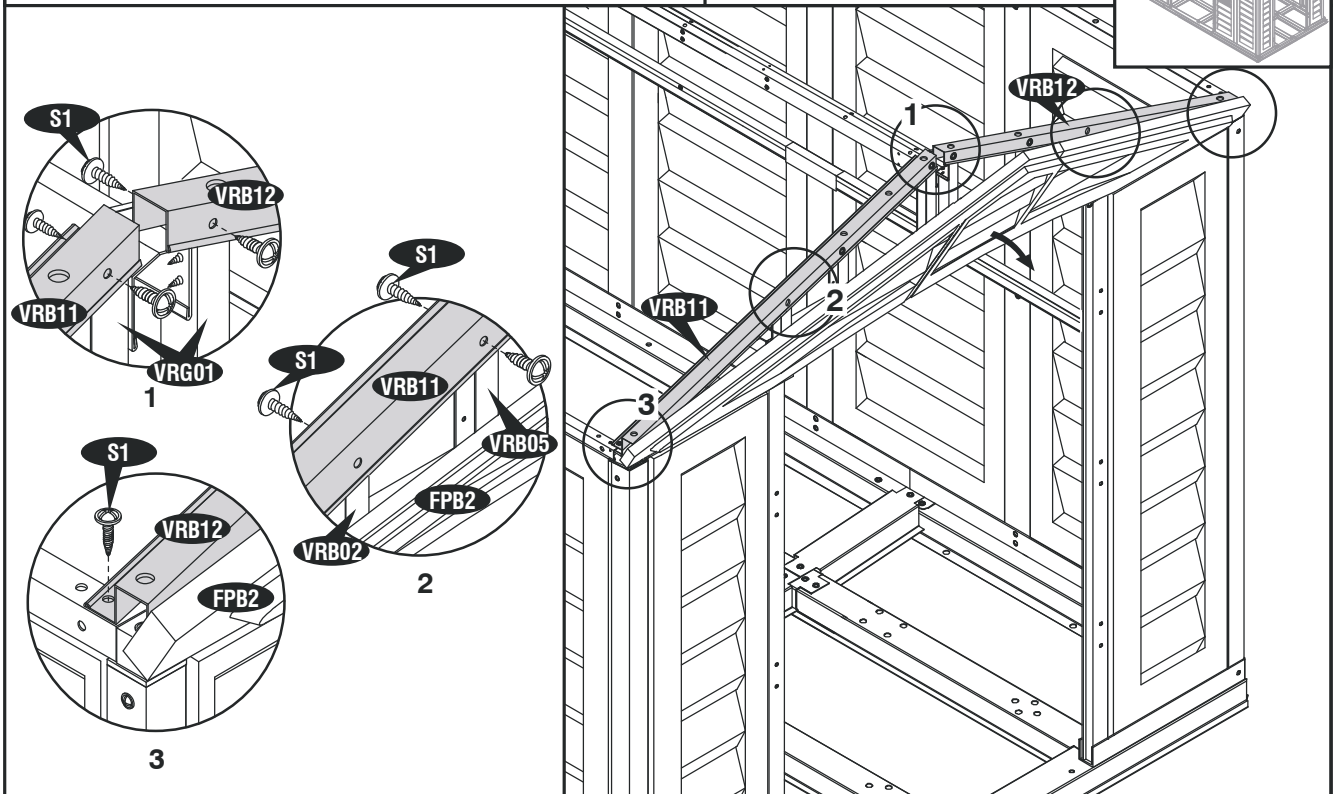
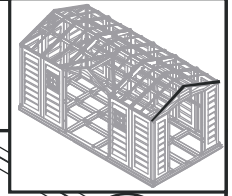

55

(EN) IMPORTANT: USE HAND GLOVES TO PREVENT INJURY.  
(FR) IMPORTANT: UTILISER LES GANTS POUR PREVENIR LES ACCIDENTS.

(ES) IMPORTANTE: GUANTES DE MANO DE USO PARA PREVENIR LA HERIDA.

12

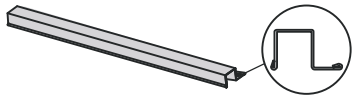

VRB11 (x1)  
VRB12 (x1)

S1 (x10)

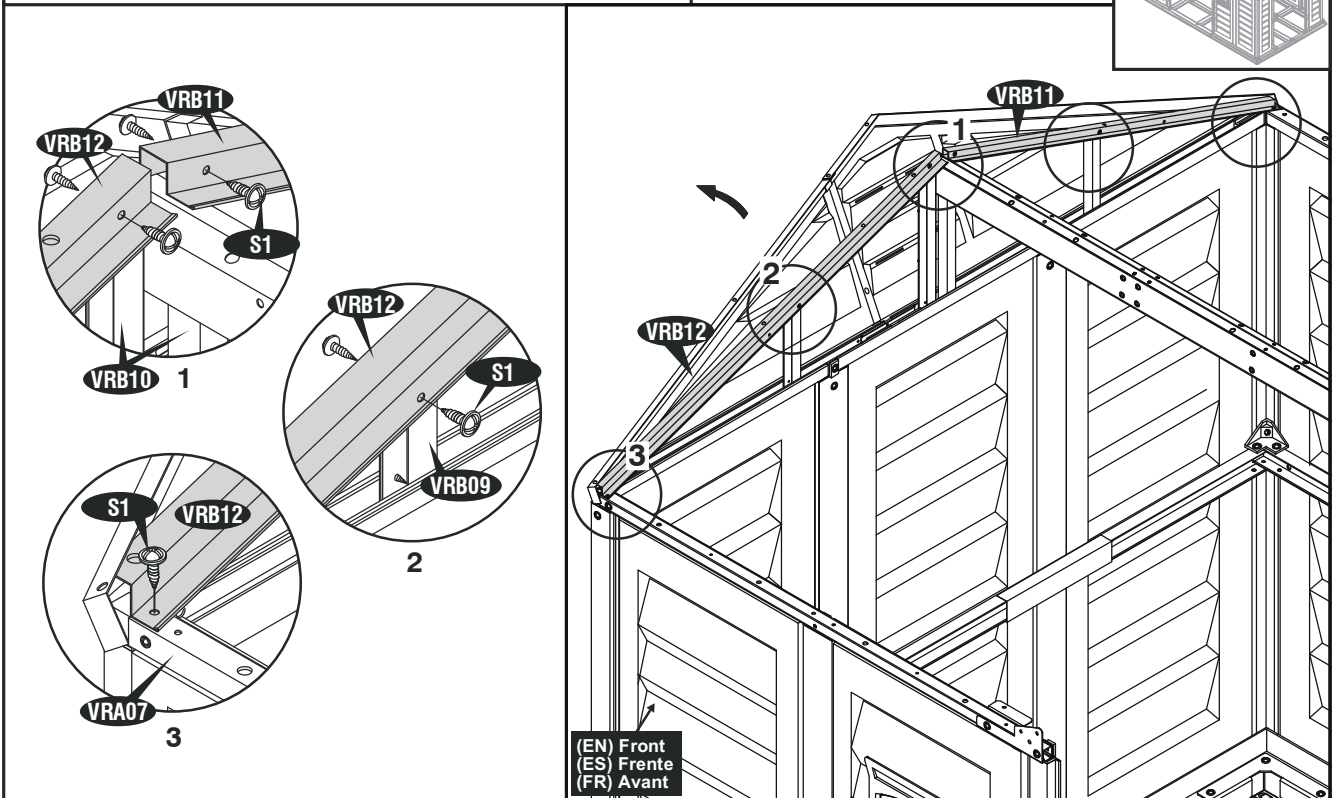
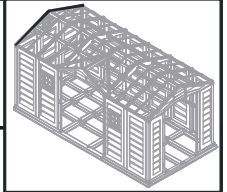

(EN) Front  
(ES) Frente  
(FR) Avant

13

J

K

S1 (x8)

S7 (x2)

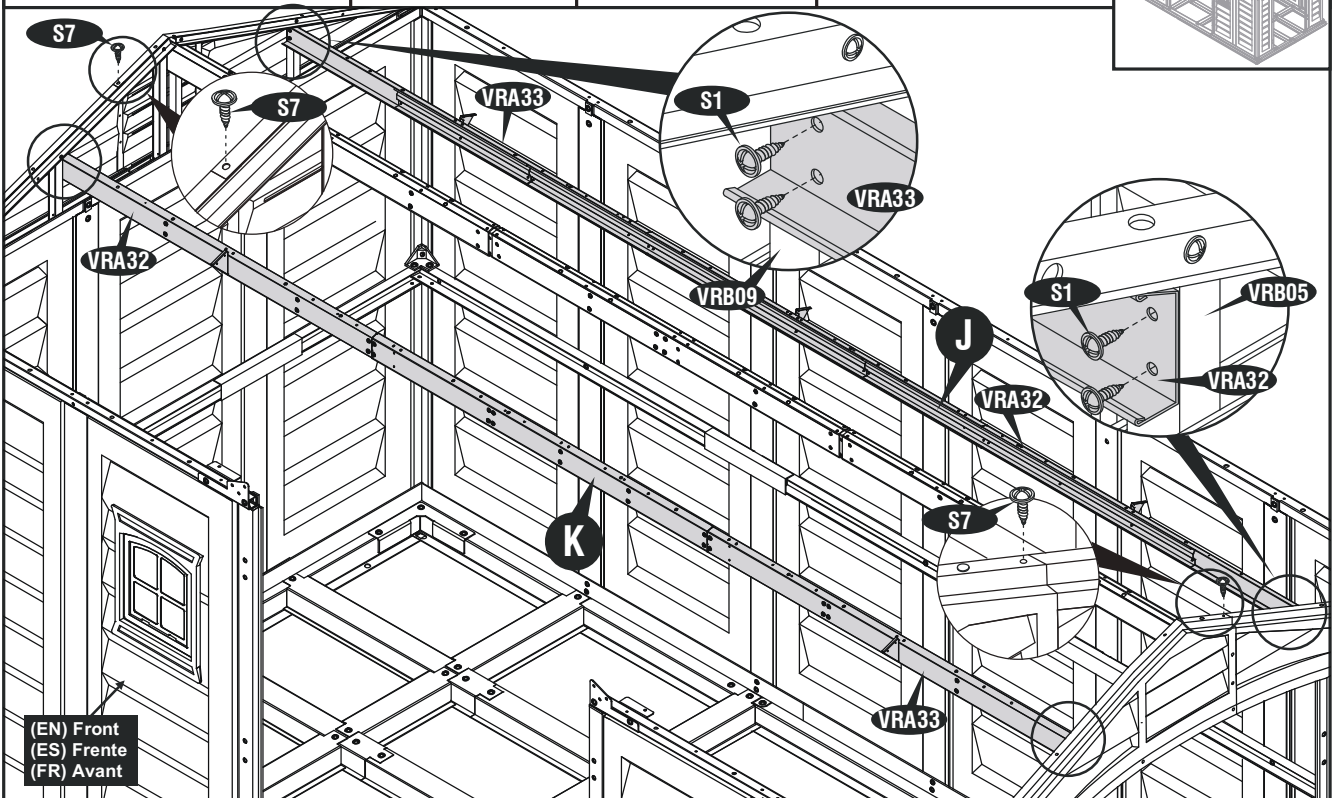
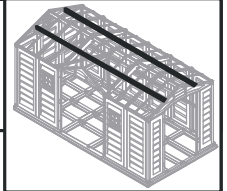

(EN) Front  
(ES) Frente  
(FR) Avant

56

(EN) IMPORTANT: USE HAND GLOVES TO PREVENT INJURY.  
(FR) IMPORTANT: UTILISER LES GANTS POUR PREVENIR LES ACCIDENTS.

(ES) IMPORTANTE: GUANTES DE MANO DE USO PARA PREVENIR LA HERIDA.

14

VRG14 (1)

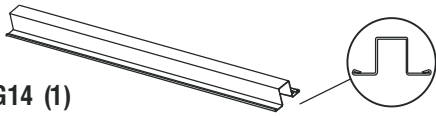

S7 (x4)

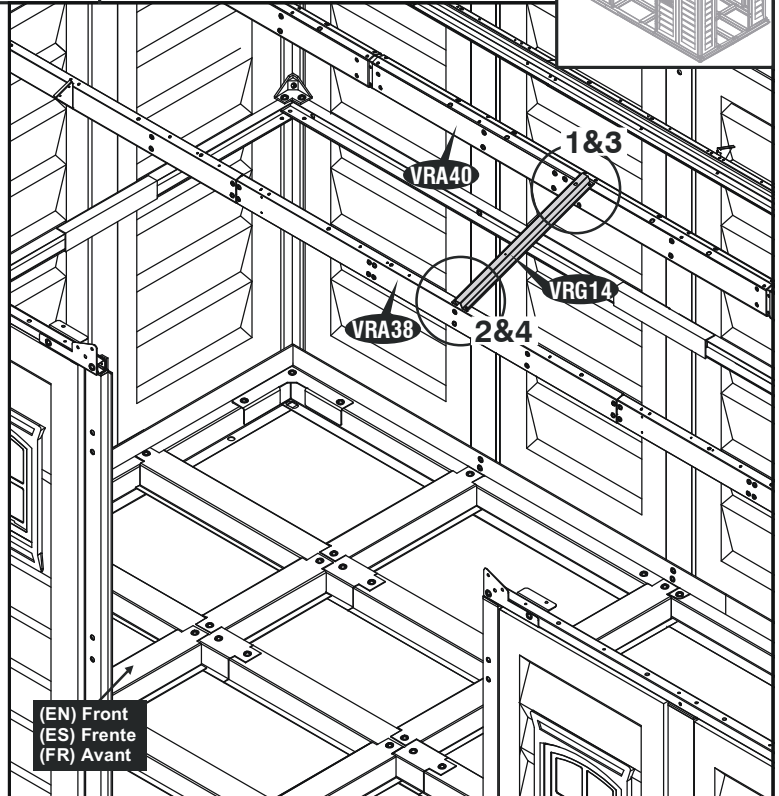
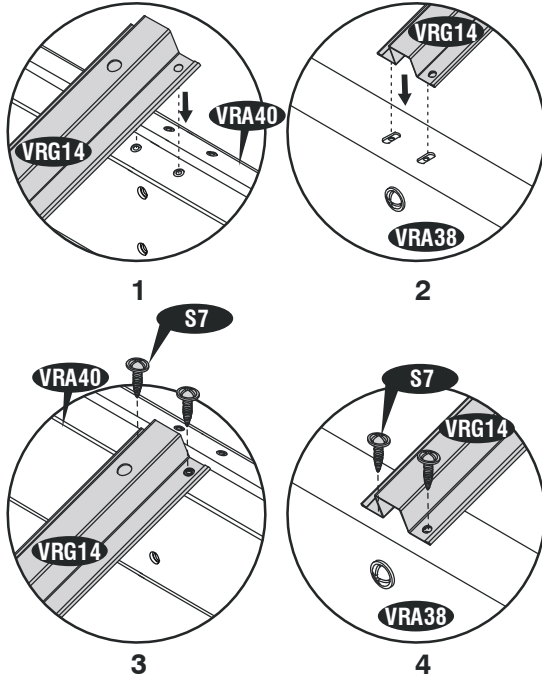
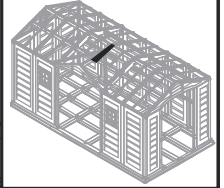

15

L

S1 (x5)

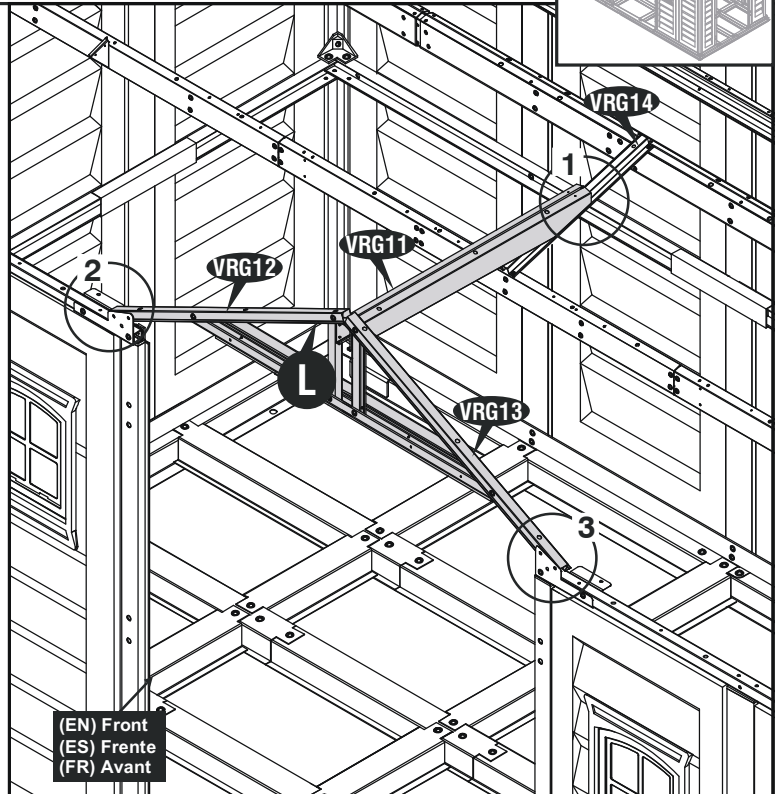
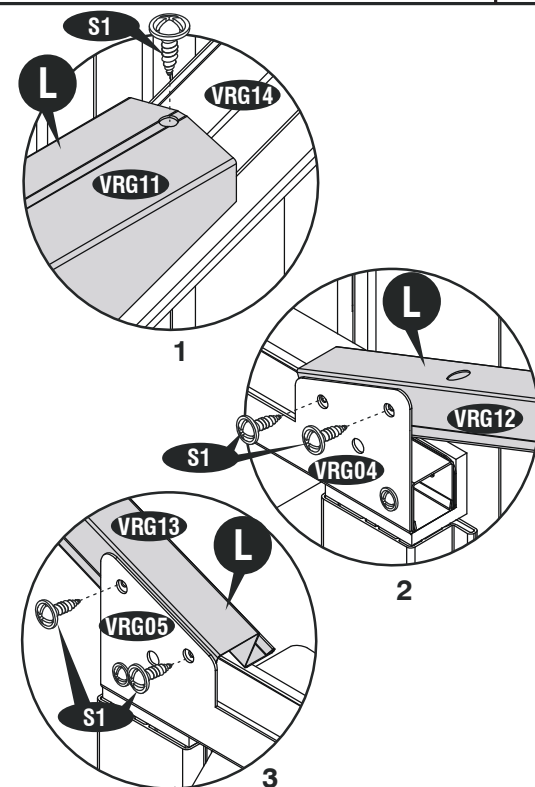
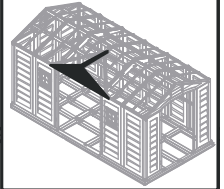

57

(EN) IMPORTANT: USE HAND GLOVES TO PREVENT INJURY.  
(FR) IMPORTANT: UTILISER LES GANTS POUR PREVENIR LES ACCIDENTS.

(ES) IMPORTANTE: GUANTES DE MANO DE USO PARA PREVENIR LA HERIDA.

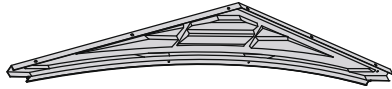

FPG1 (x1)



FP (x4)

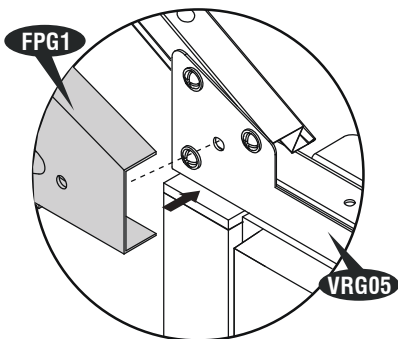
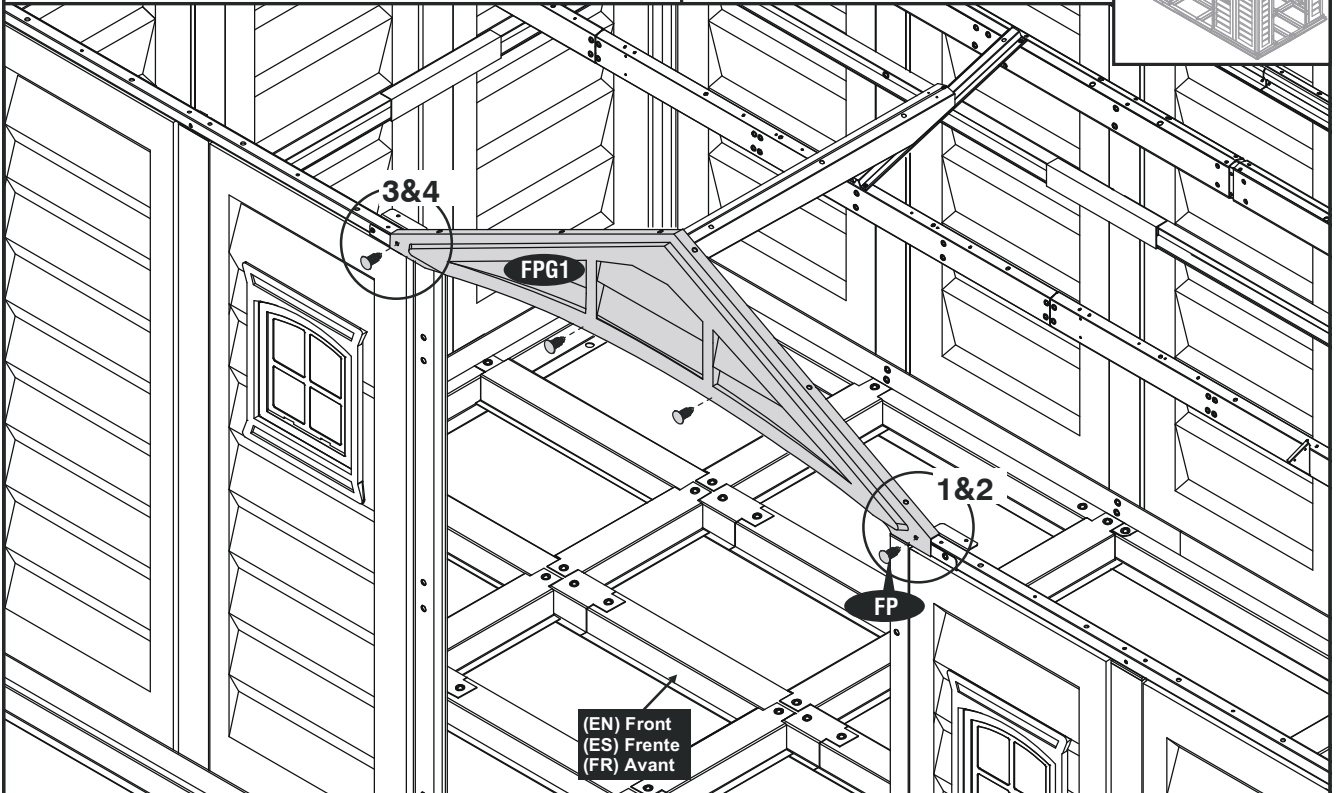
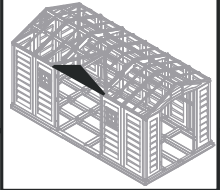

1

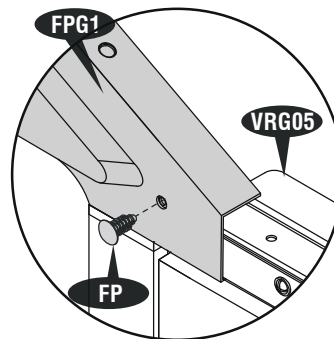

2

(EN) View from inside  
(ES) Vista desde el interior  
(FR) Vue de l'intérieur

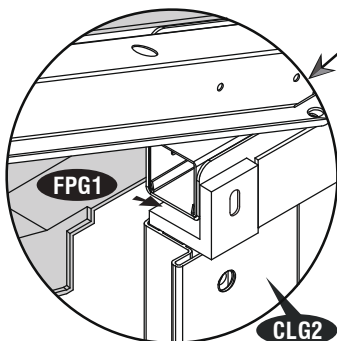

3

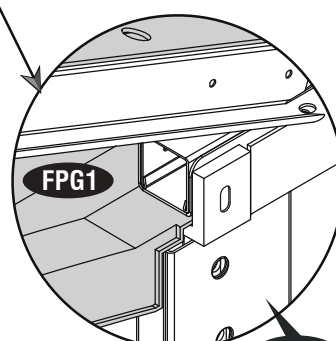

4

M

S1 (x12)

S7 (x4)

SG1 (x2)

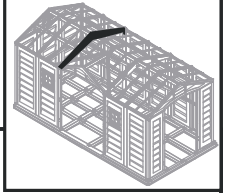

(EN) Front  
(ES) Frente  
(FR) Avant

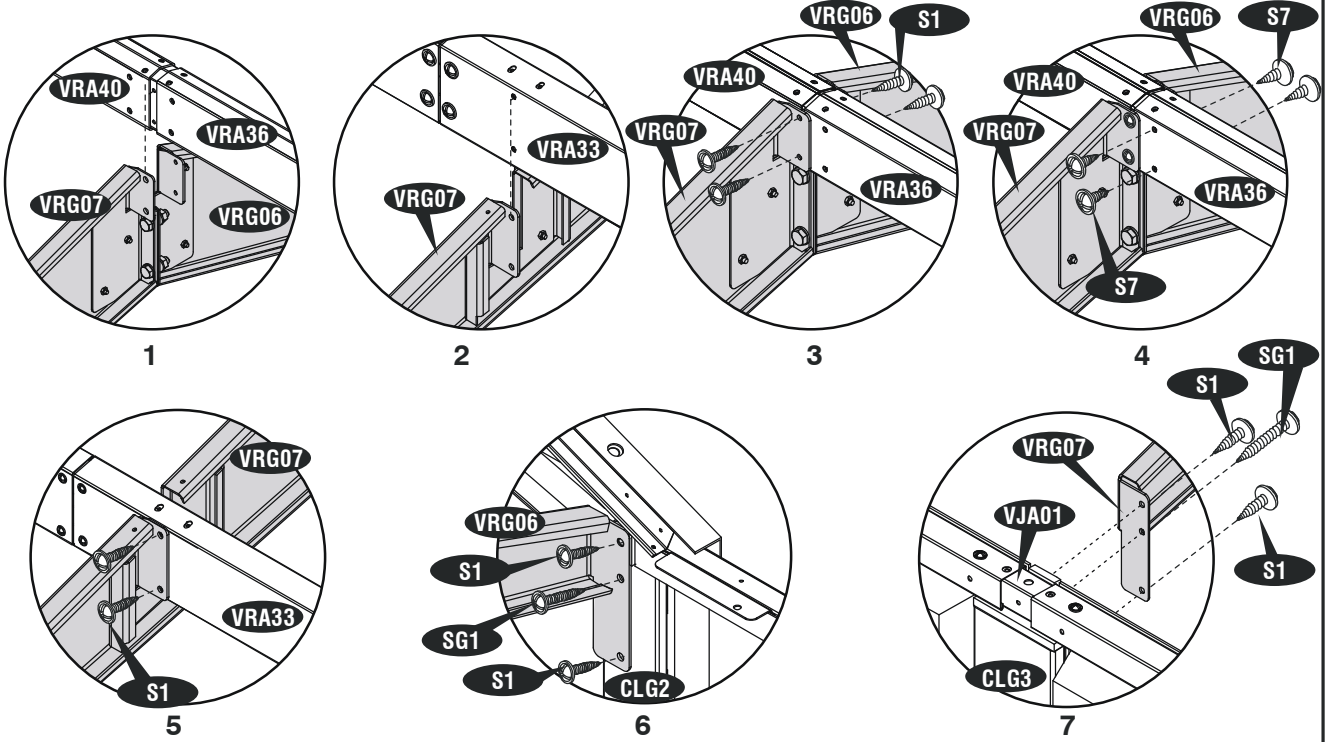
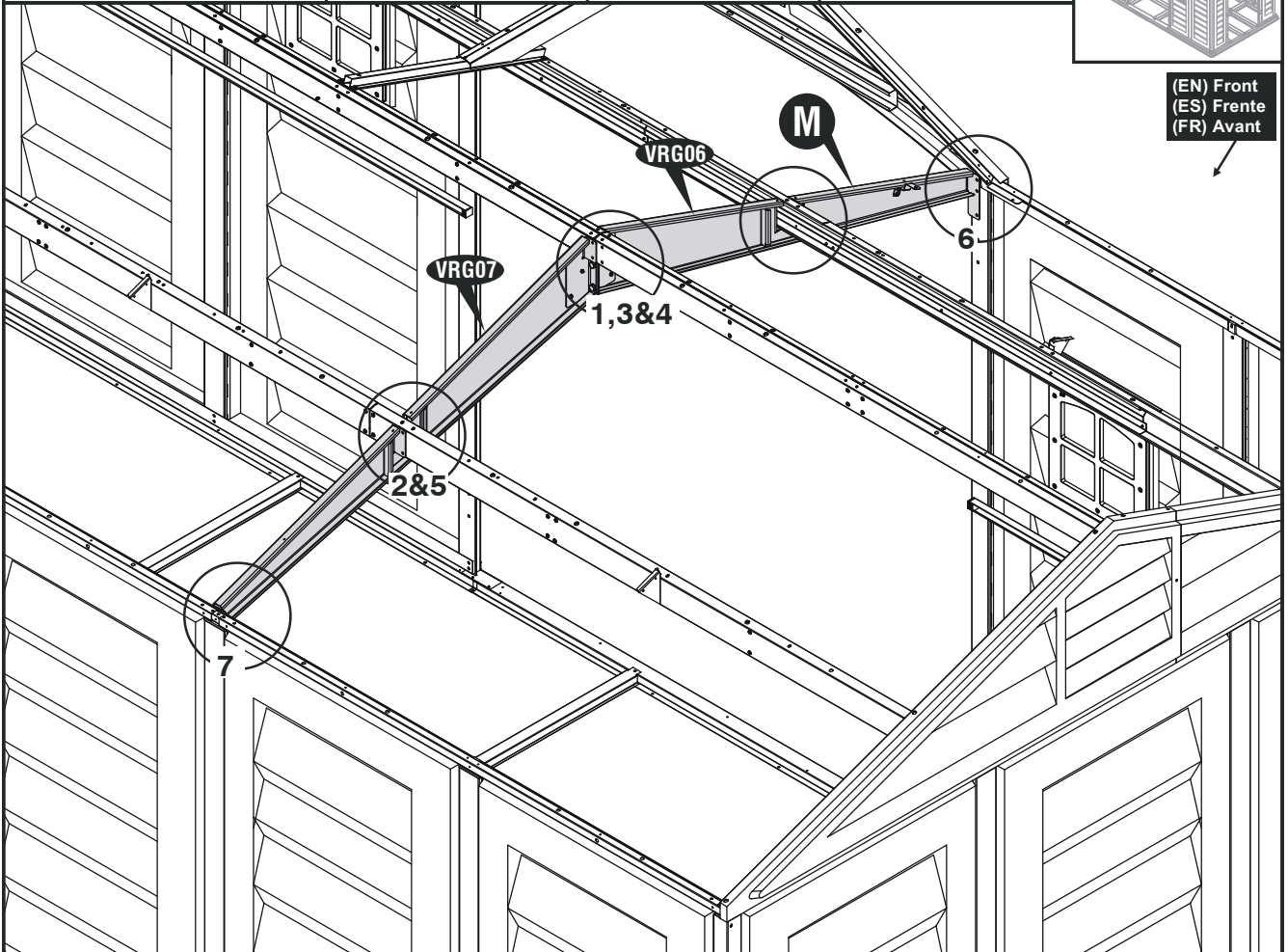

M

S1 (x12)

S7 (x4)

SG1 (x2)

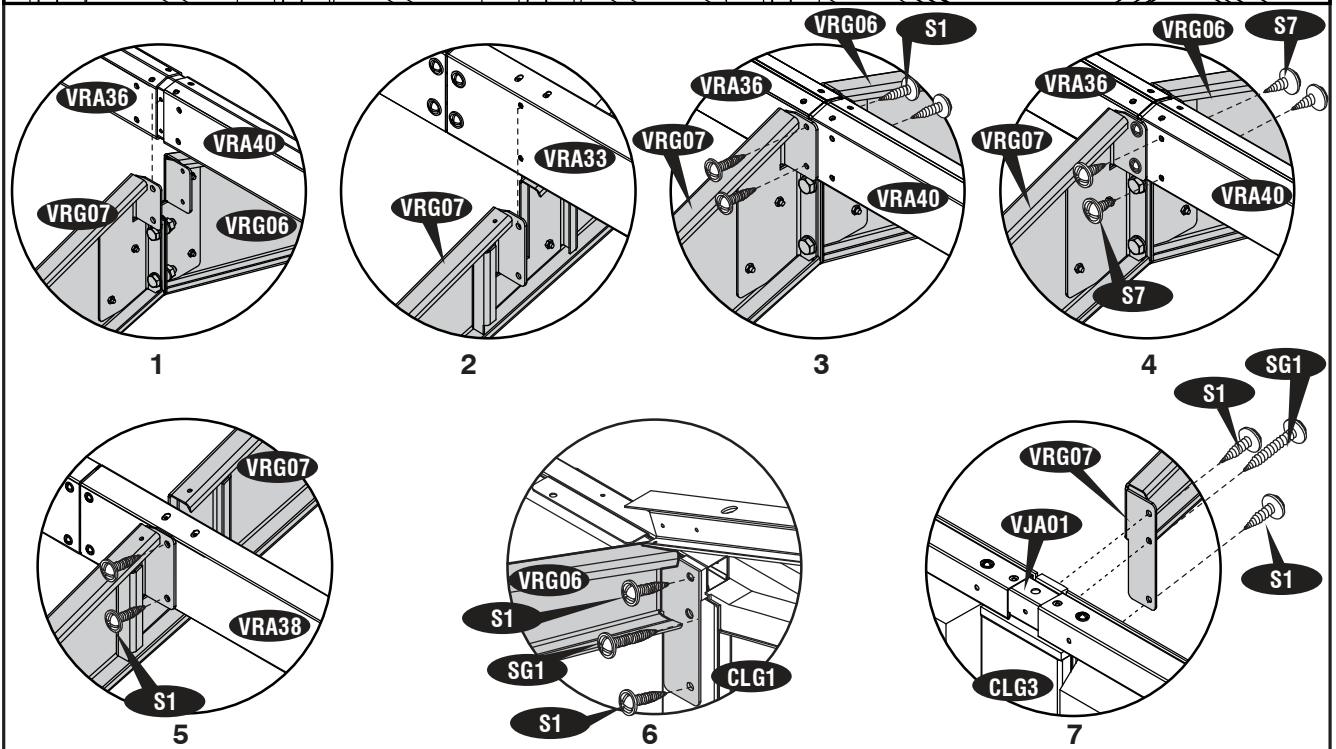
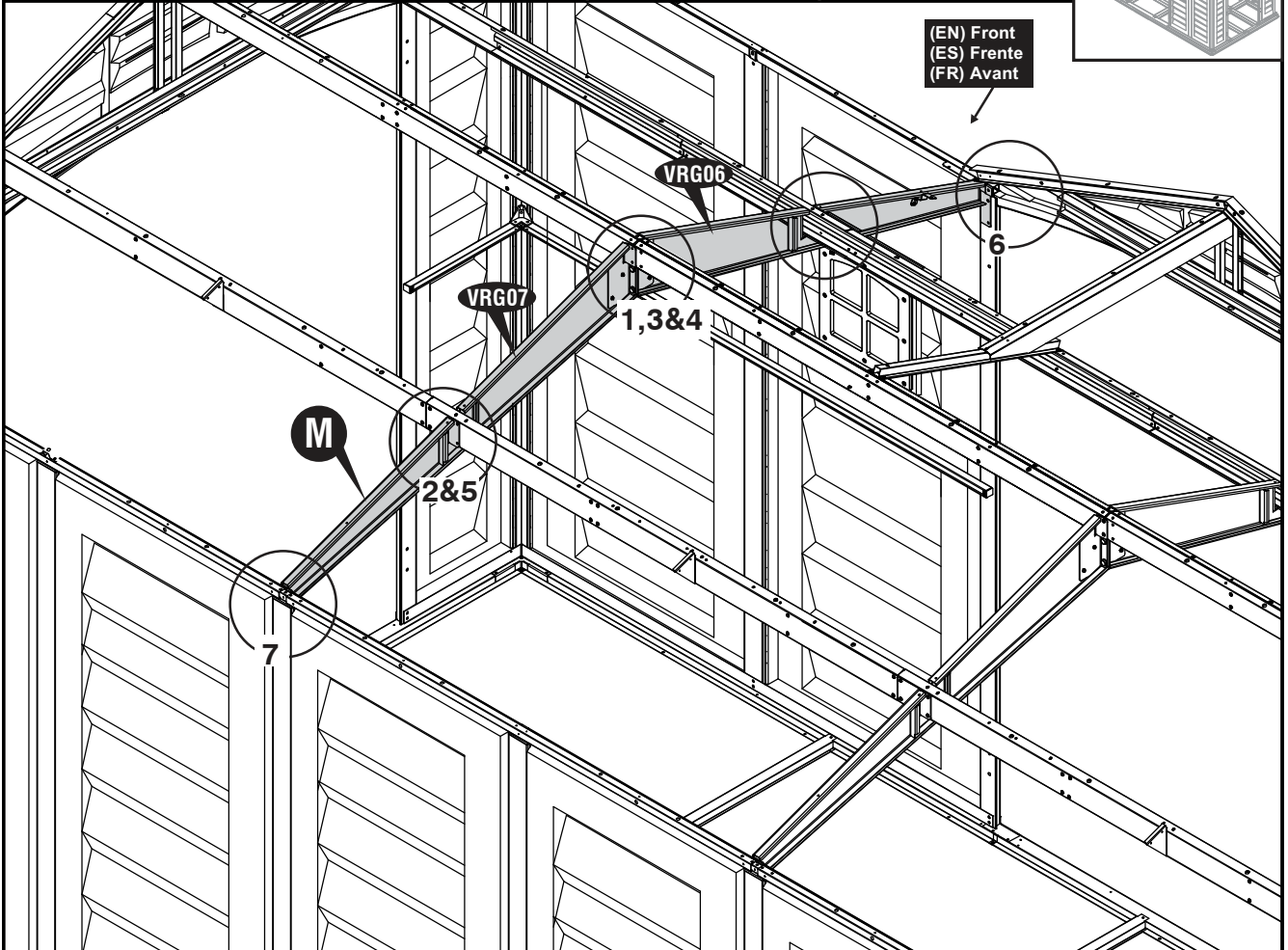
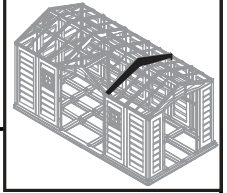

19

VRG20 (5)

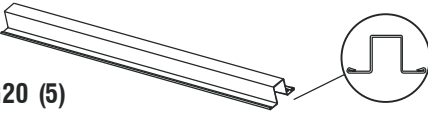

S1 (x10)

S7 (x30)

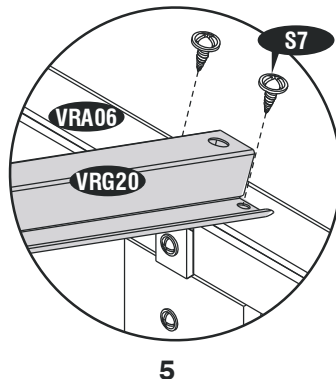
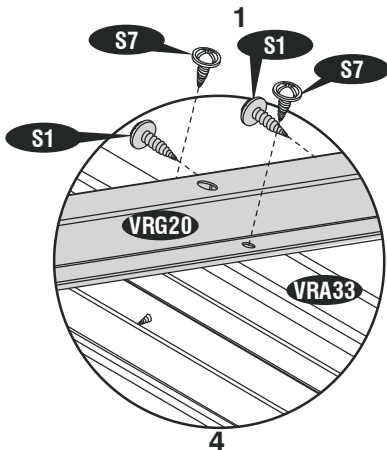
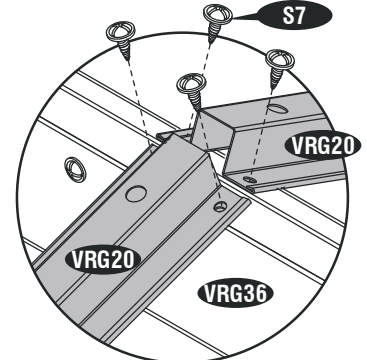
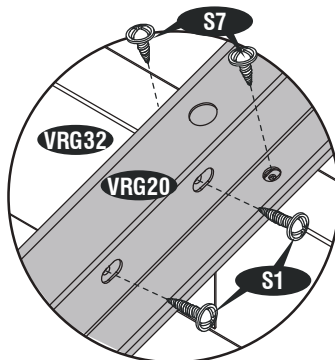
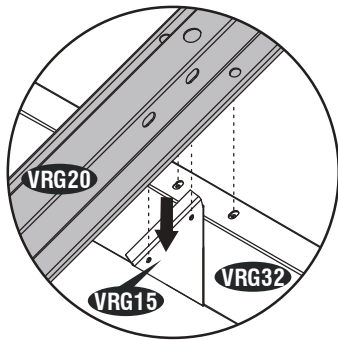
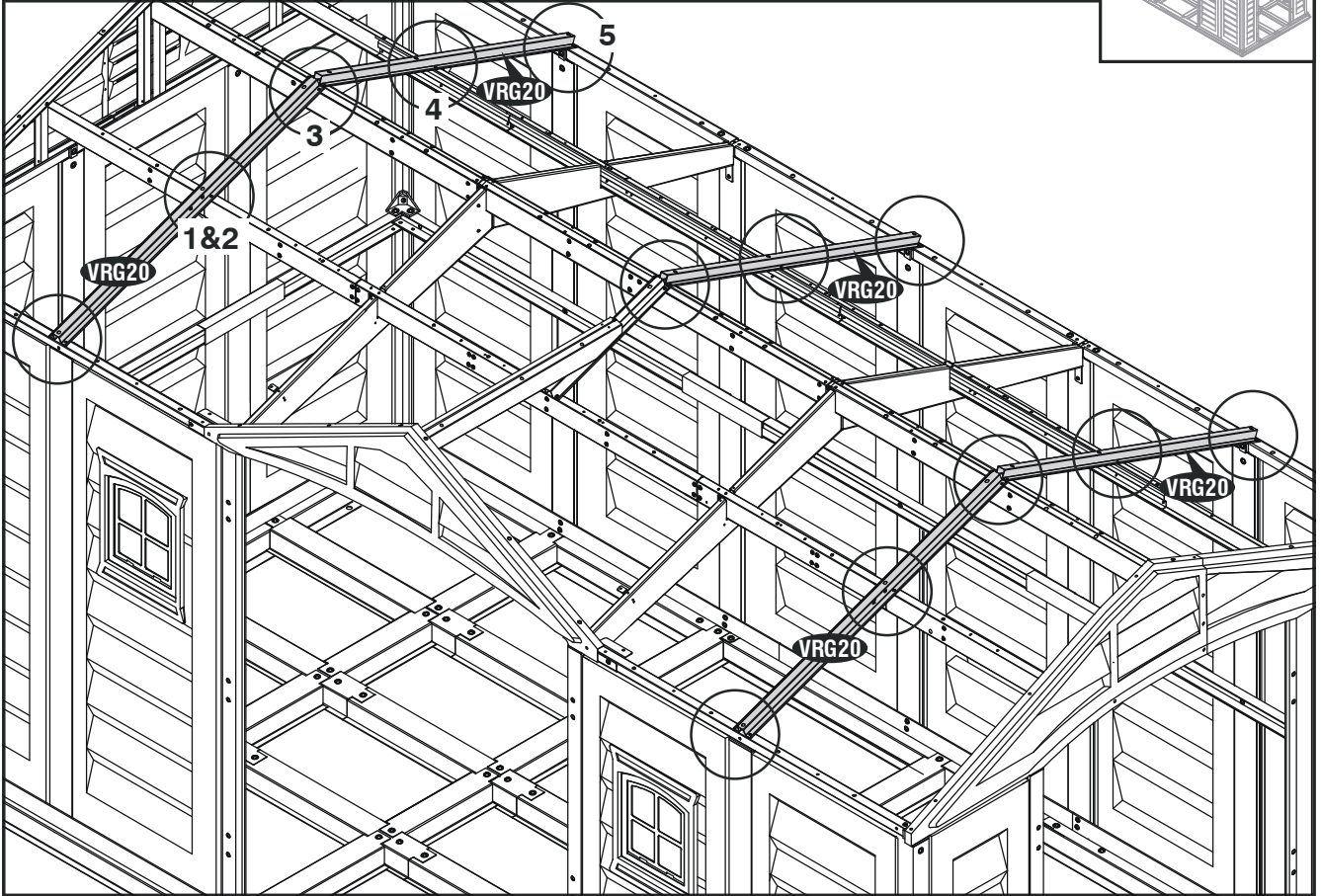
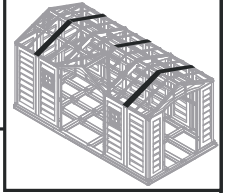

61

(EN) IMPORTANT: USE HAND GLOVES TO PREVENT INJURY.  
(FR) IMPORTANT: UTILISER LES GANTS POUR PREVENIR LES ACCIDENTS.

(ES) IMPORTANTE: GUANTES DE MANO DE USO PARA PREVENIR LA HERIDA.

20

VRG21 (2)

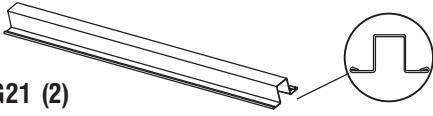

S7 (x16)

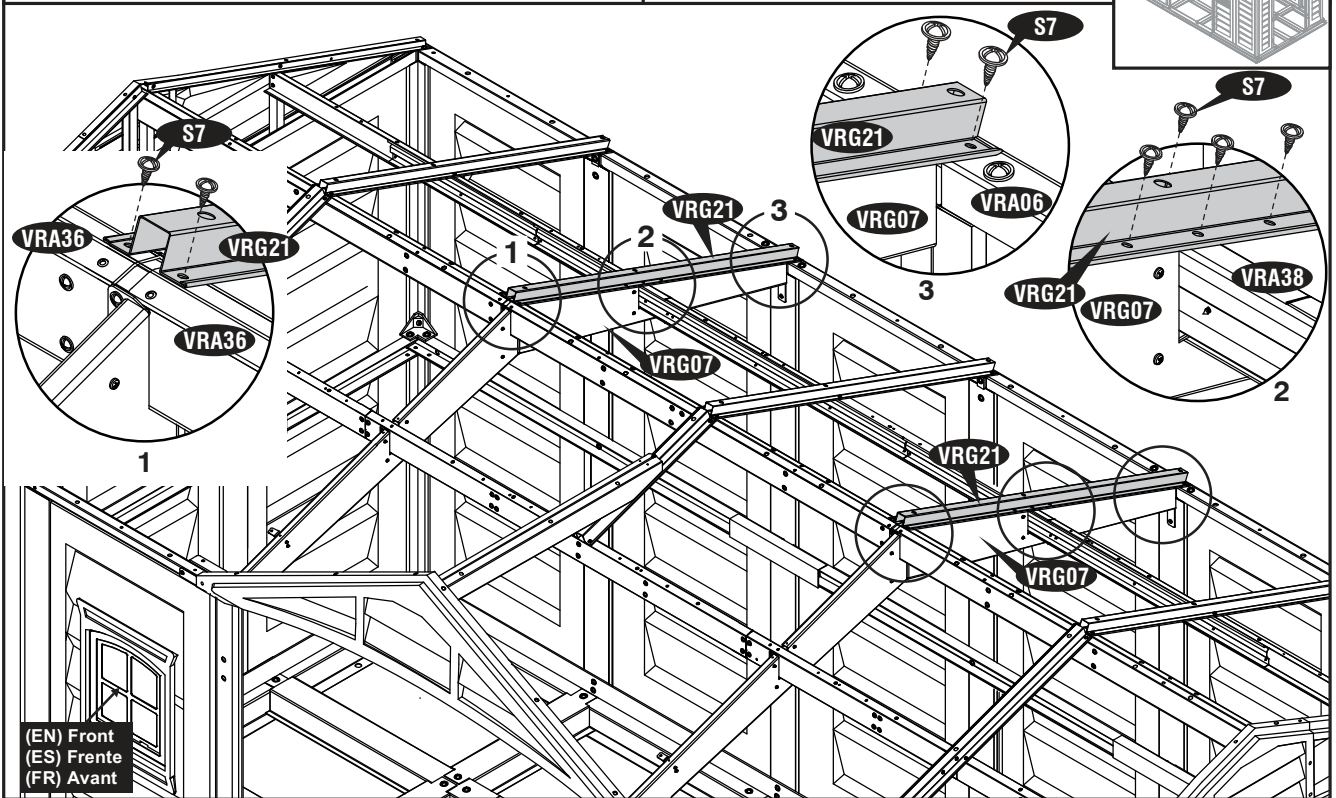
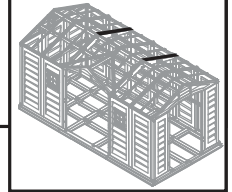

(EN) Front  
(ES) Frente  
(FR) Avant

21

VRG22 (2)

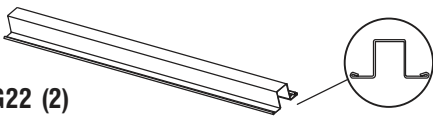

S7 (x16)

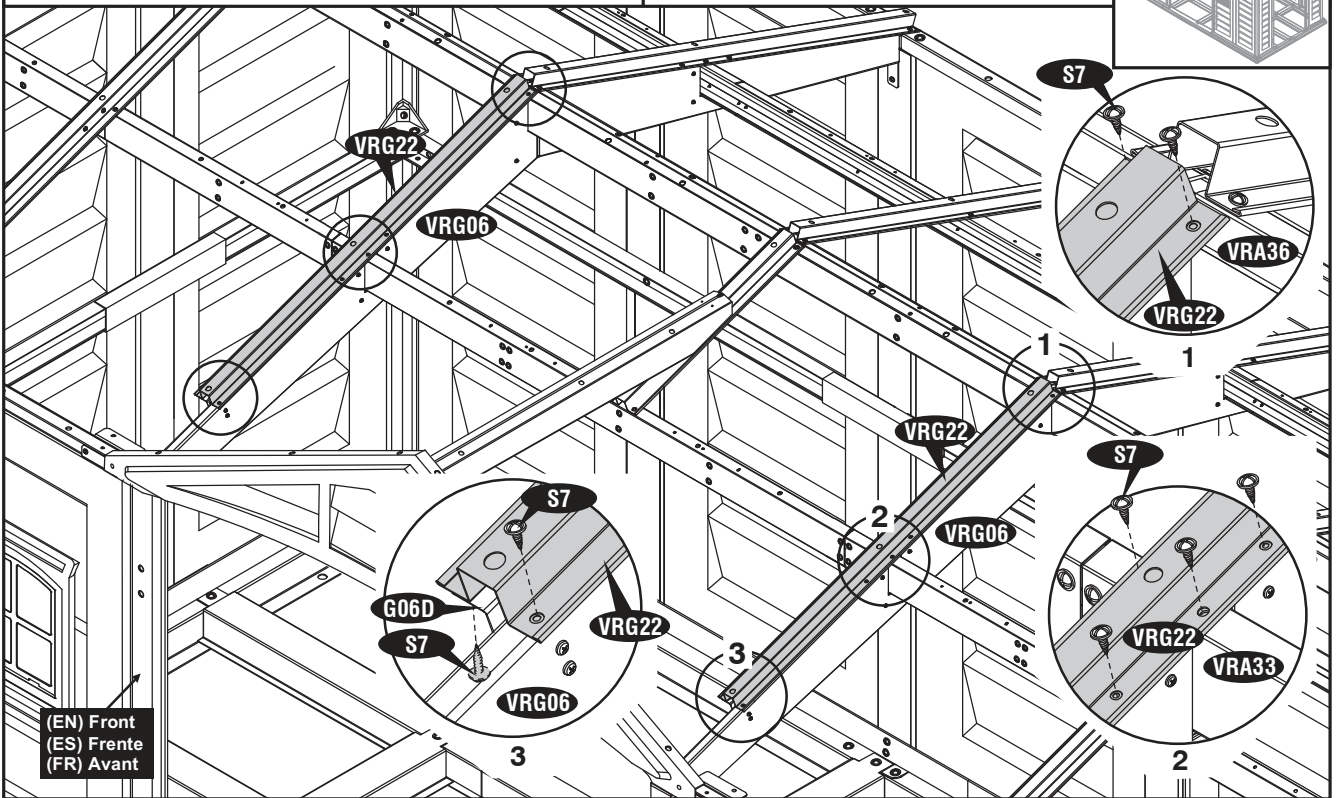
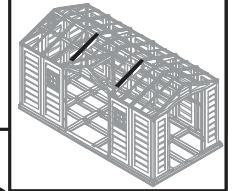

(EN) Front  
(ES) Frente  
(FR) Avant

62

(EN) IMPORTANT: USE HAND GLOVES TO PREVENT INJURY.  
(FR) IMPORTANT: UTILISER LES GANTS POUR PREVENIR LES ACCIDENTS.

(ES) IMPORTANTE: GUANTES DE MANO DE USO PARA PREVENIR LA HERIDA.



22

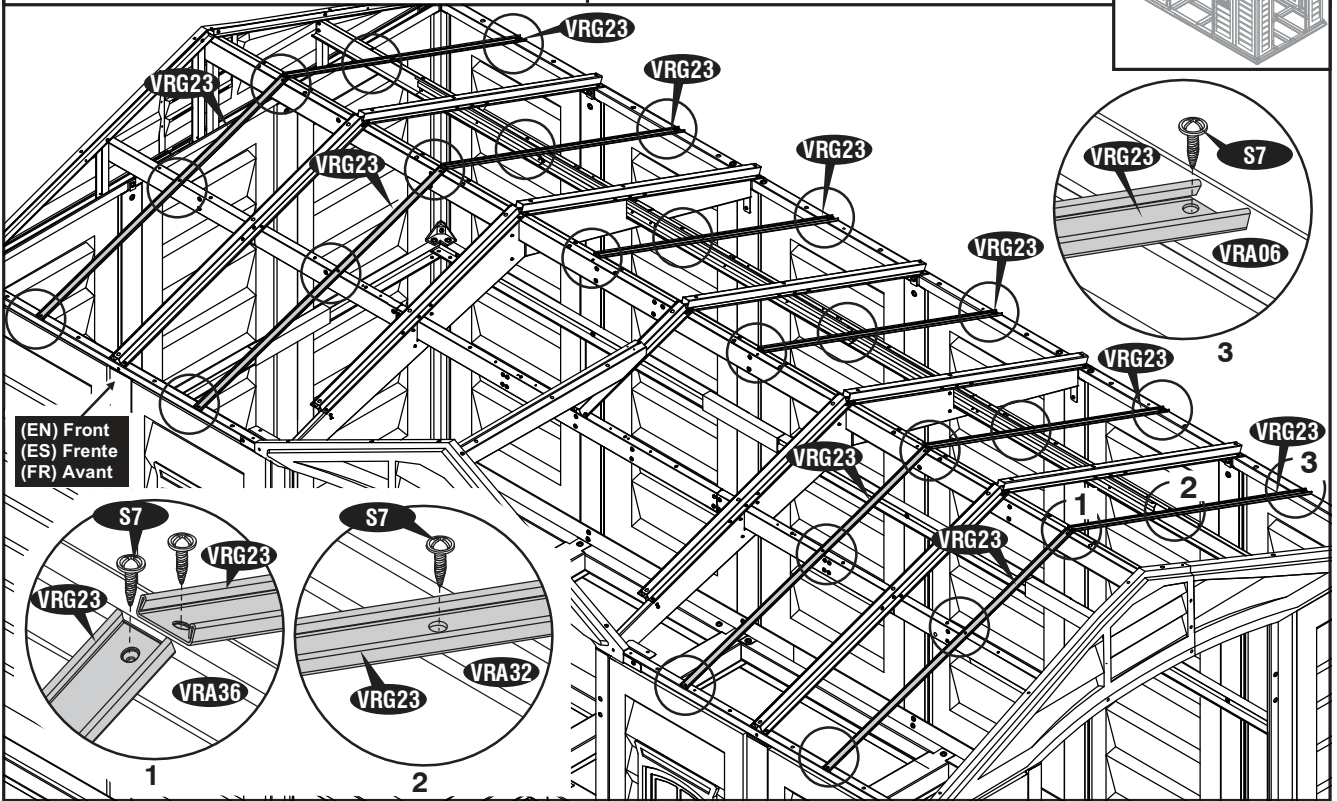
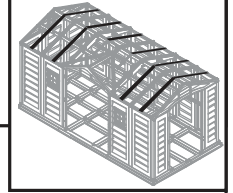

23

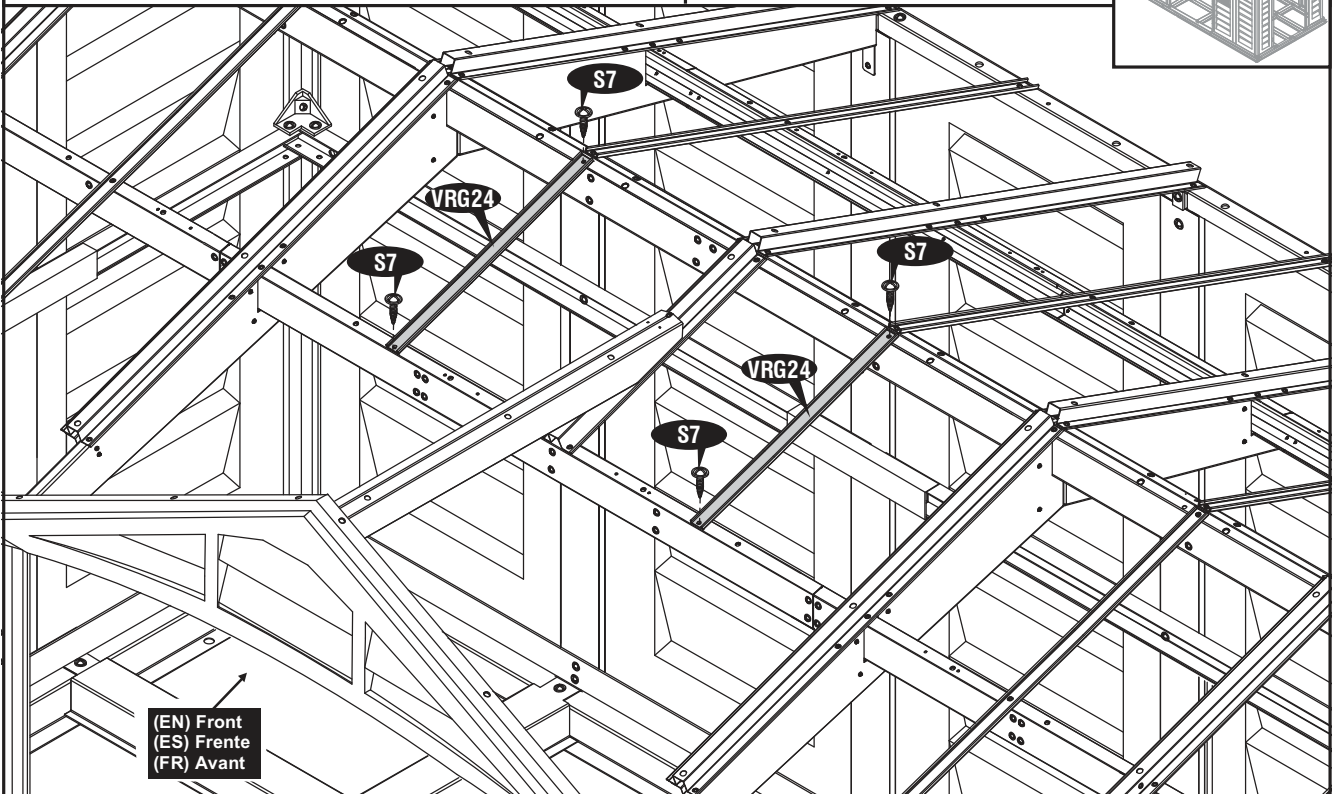
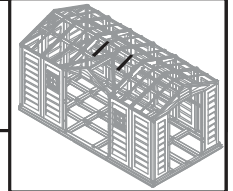
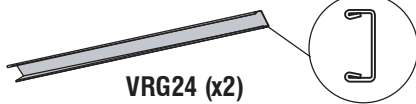

63

(EN) IMPORTANT: USE HAND GLOVES TO PREVENT INJURY.  
(FR) IMPORTANT: UTILISER LES GANTS POUR PREVENIR LES ACCIDENTS.

(ES) IMPORTANTE: GUANTES DE MANO DE USO PARA PREVENIR LA HERIDA.

24

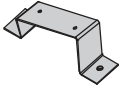

VRG16 (x1)

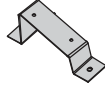

VRG17 (x1)



S1 (x4)

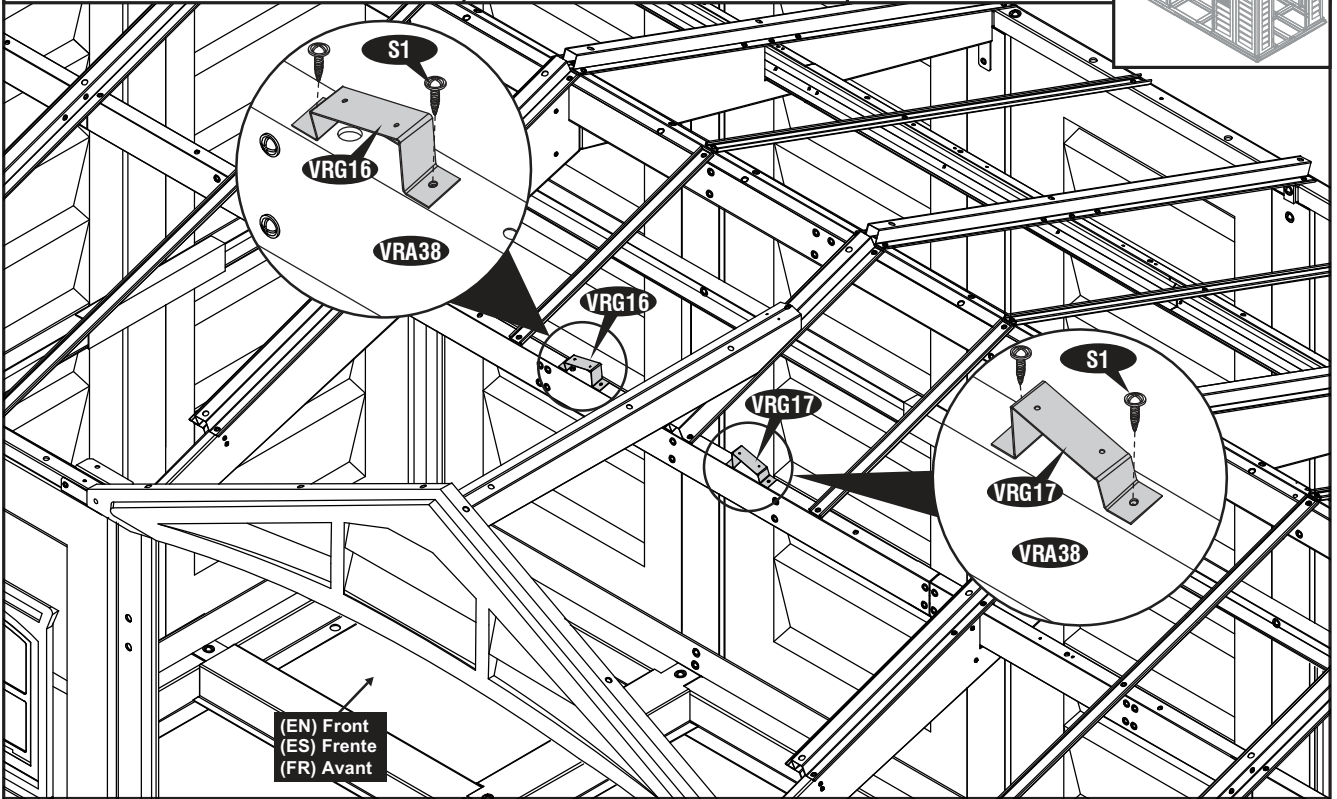
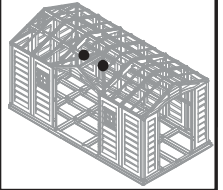

(EN) Front  
(ES) Frente  
(FR) Avant

25

VRG18 (x1)  
VRG19 (x1)

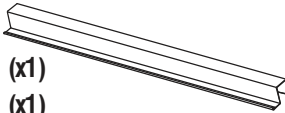

S7 (x8)



S1 (x2)

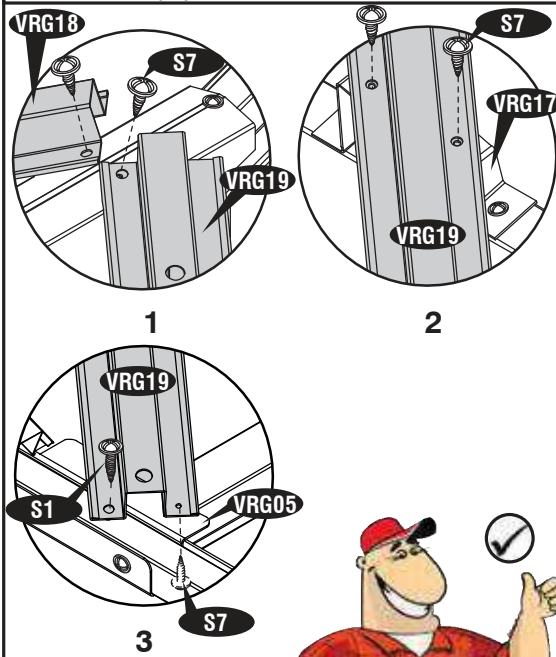
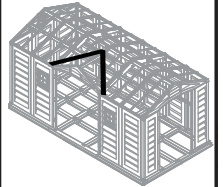

1

2

3

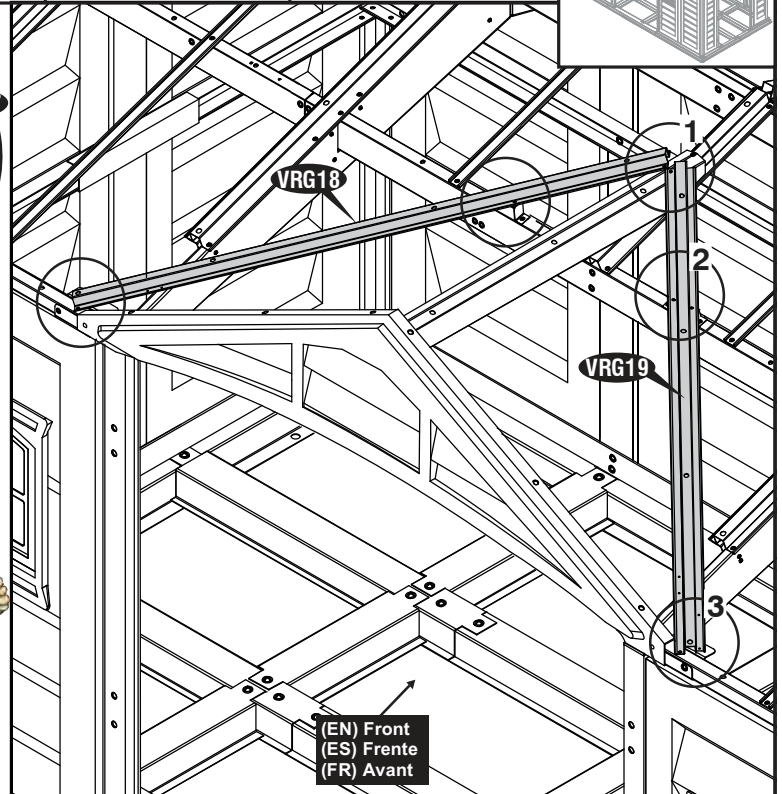

(EN) Front  
(ES) Frente  
(FR) Avant

64

(EN) IMPORTANT: USE HAND GLOVES TO PREVENT INJURY.  
(FR) IMPORTANT: UTILISER LES GANTS POUR PREVENIR LES ACCIDENTS.

(ES) IMPORTANTE: GUANTES DE MANO DE USO PARA PREVENIR LA HERIDA.



**6** (EN) Roof Panels  
(ES) Paneles de techo  
(FR) Panneaux de toiture



(EN) Parts needed  
(ES) Las partes necesitaron  
(FR) Pièces nécessaires

(EN)CODE (ES)CODE (FR)CODE	(EN)QTY (ES)QTY (FR)QTÉ
RPD1	1
RPD3	1
RPD4	1
RPD5	4
RPD6	1
RPG1	1
RPG2	1
RPG3	1
RPG4	1
RPG5	1
RPG6	1
SLG1	2
EC2	3
PPG	118
PIN	118
PPGL	5
PINL	5
FP	6



(EN) Apply silicone into the holes before inserting the pins (Silicone not included).  
(ES) Aplicar silicona en los agujeros antes de insertar los pasadores (Silicona no incluido).  
(FR) Appliquez du silicone dans les trous avant d'insérer les chevilles plastiques (silicone non inclus).

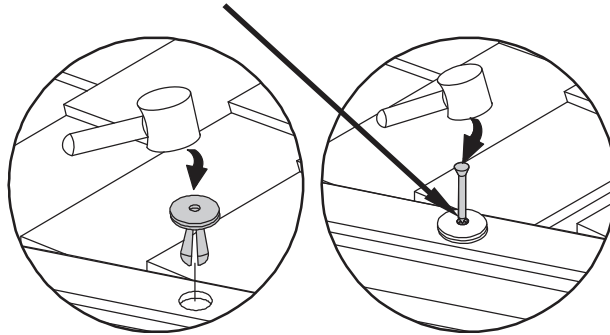

**1**

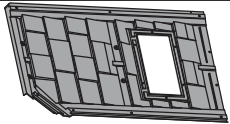

RPG4 (x1)

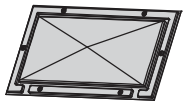

SLG1 (x1)

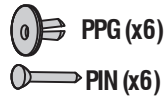

PPG (x6)  
PIN (x6)

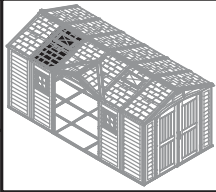

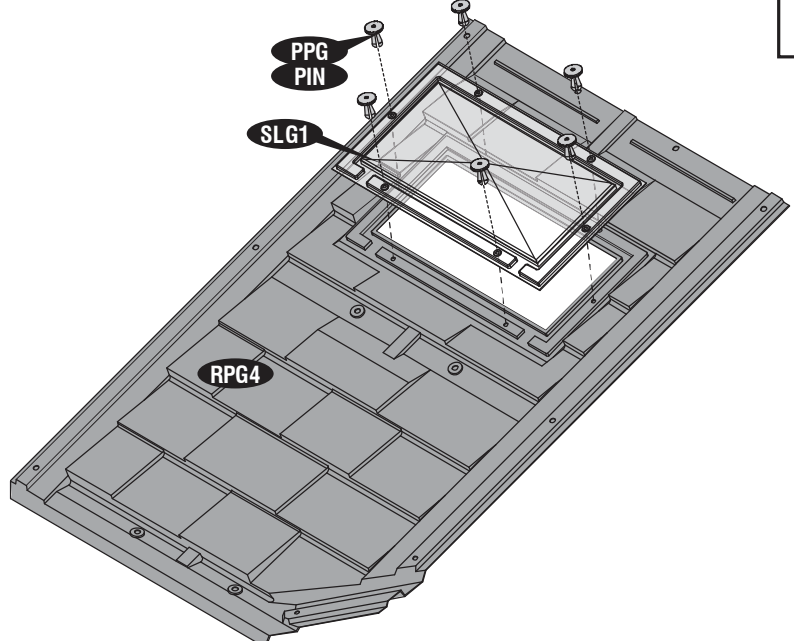

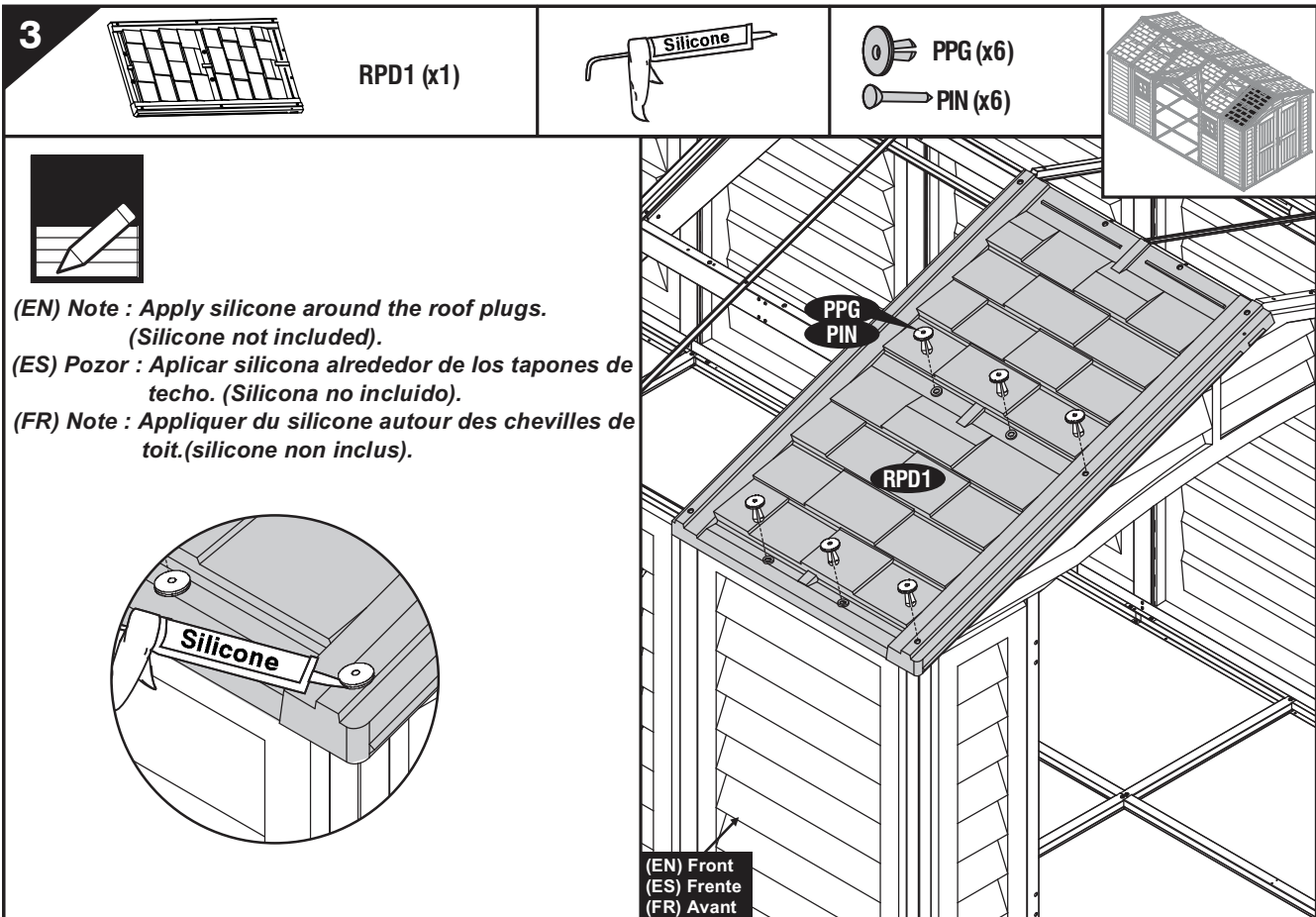
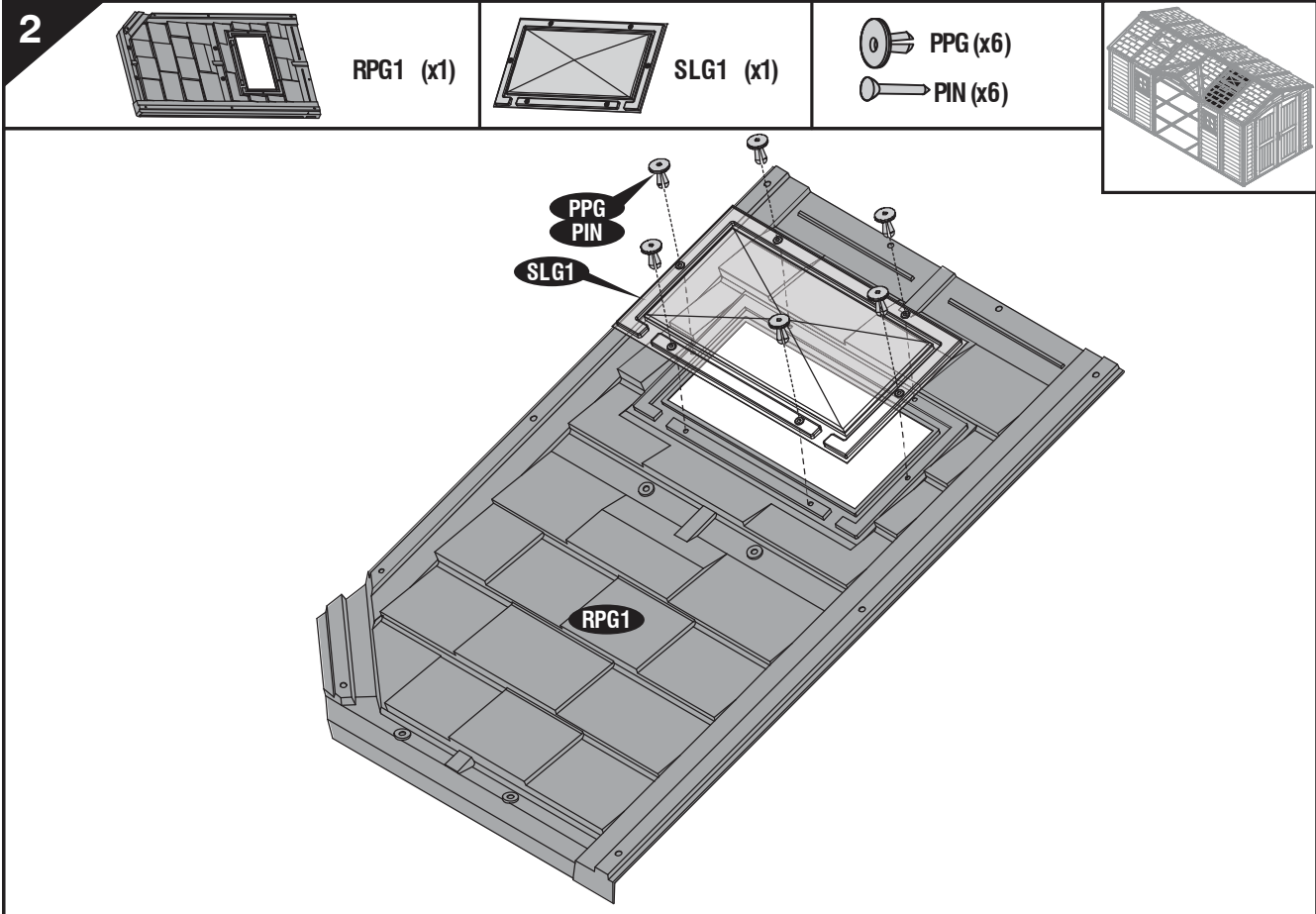

4

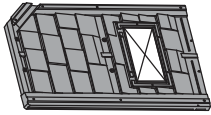

RPG1 (x1)

PPG (x6)  
PIN (x6)

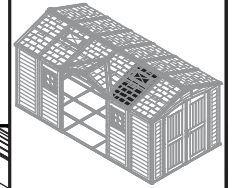

(EN) Note : Roof panels are installed by using a ladder inside of the shed at missing panels.  
 (ES) Pozor : Los paneles de techo se instalan mediante una escalera interior del cobertizo en los paneles que faltan.  
 (FR) Note : Installez les panneaux de toiture à l'aide d'une échelle en passant par l'intérieur de l'abri.

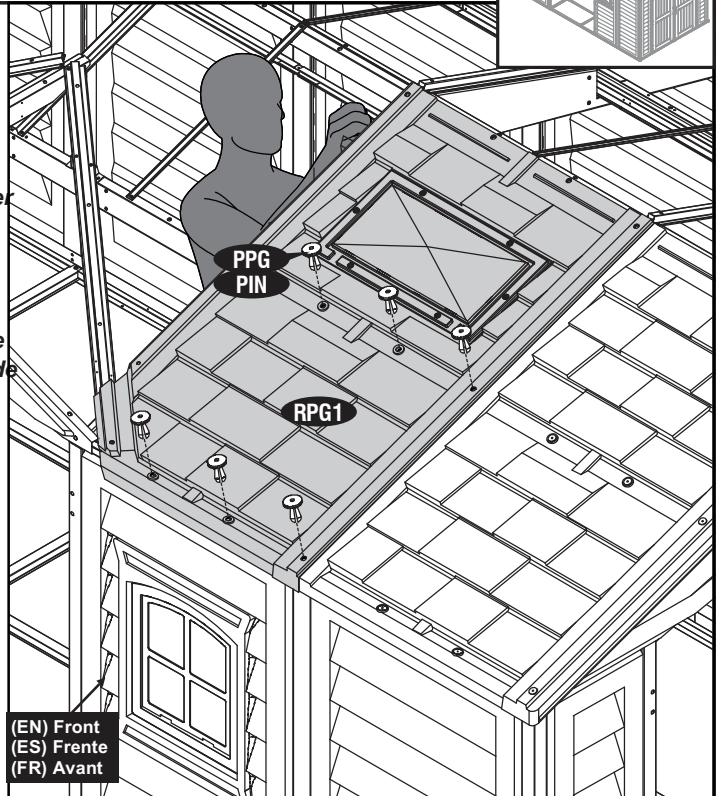

(EN) Front  
(ES) Frente  
(FR) Avant

5

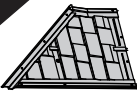

RPG2 (x1)

PPG (x3)  
PIN (x3)

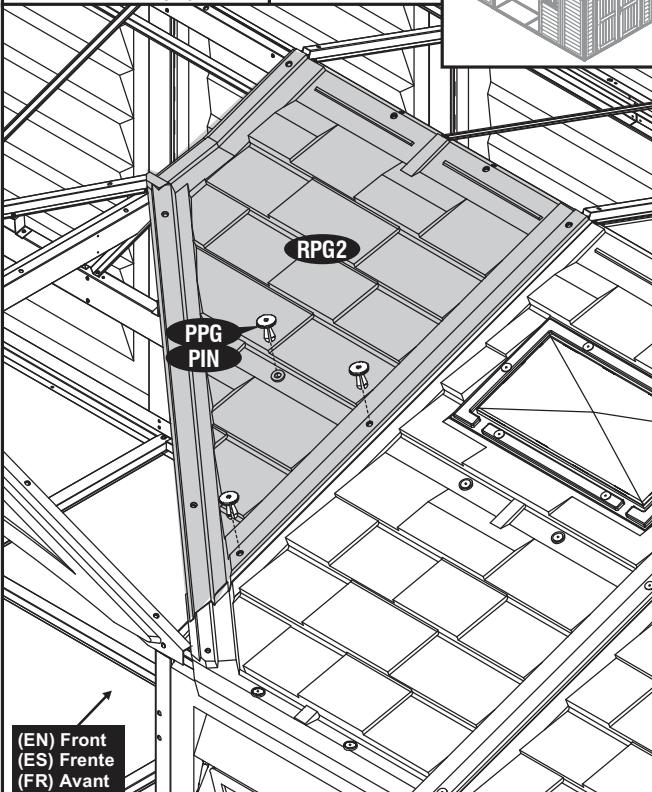
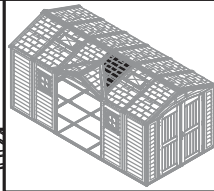

(EN) Front  
(ES) Frente  
(FR) Avant

6



RPG3 (x1)

PPG (x6)  
PIN (x6)

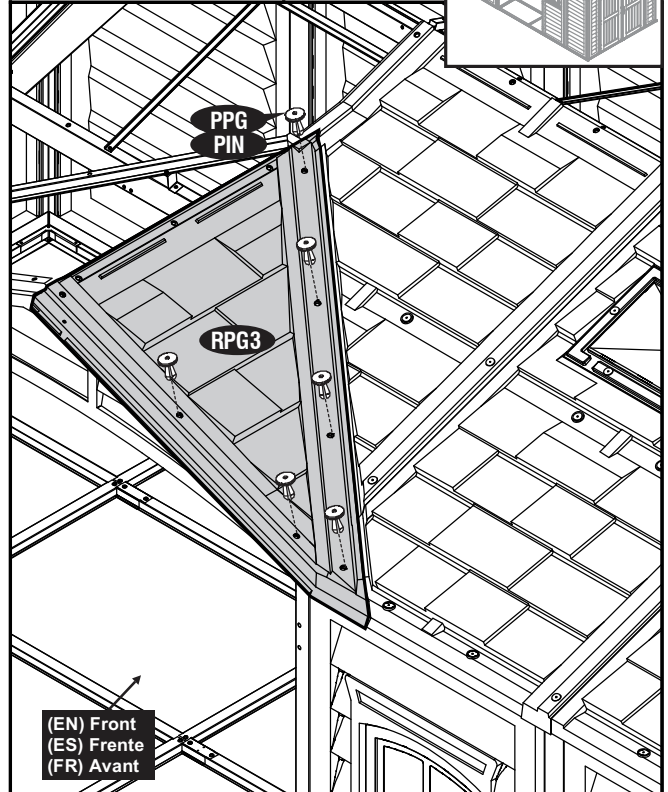
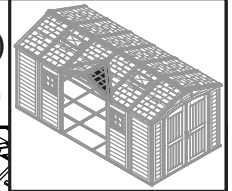

(EN) Front  
(ES) Frente  
(FR) Avant

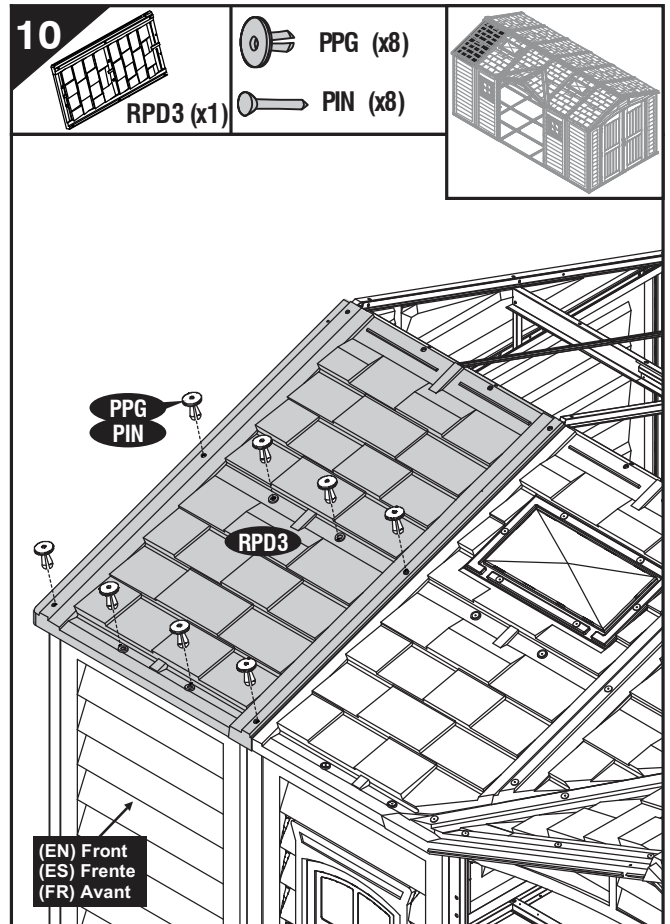
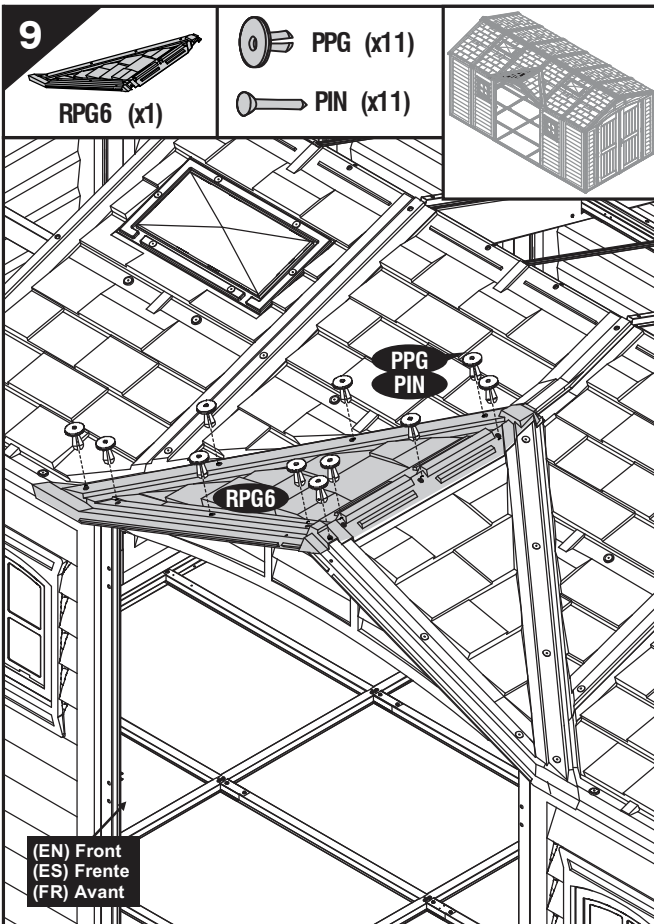
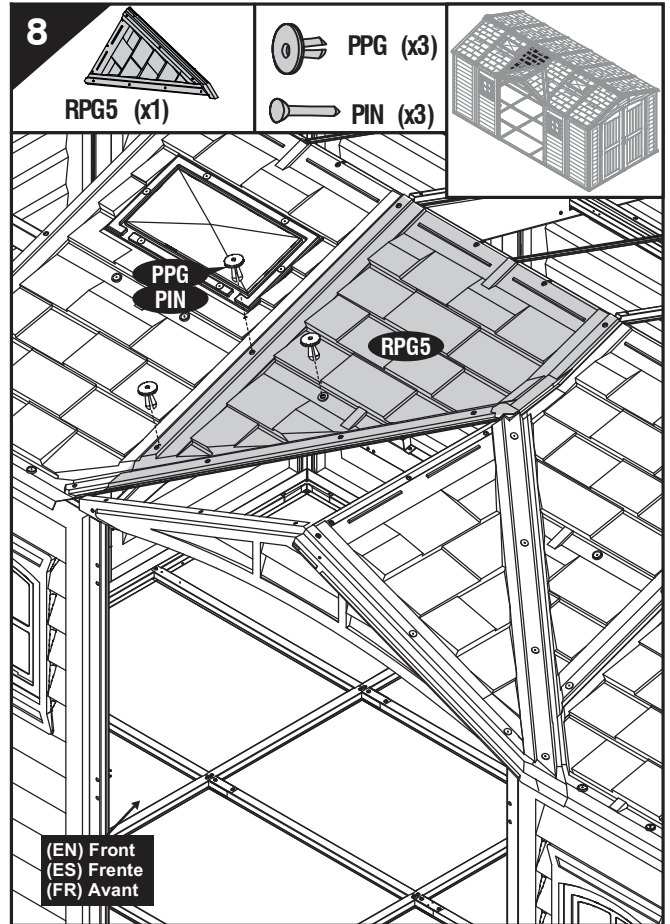
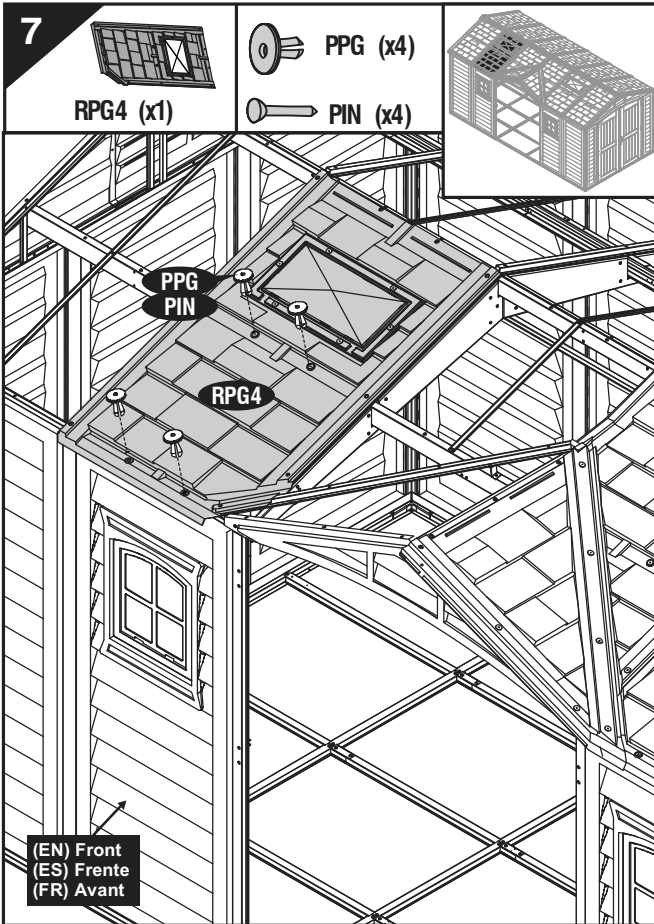

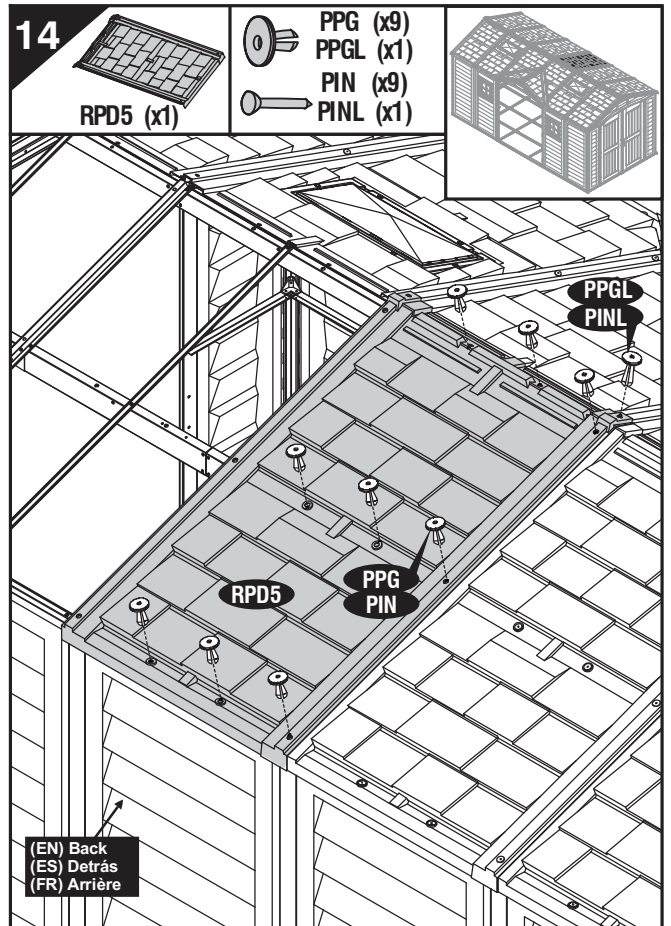
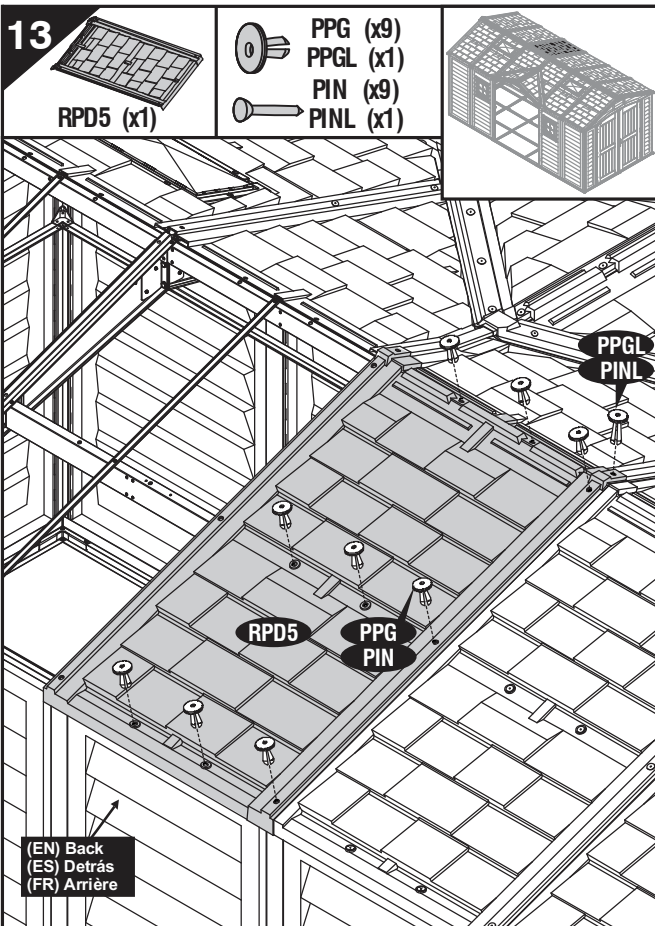
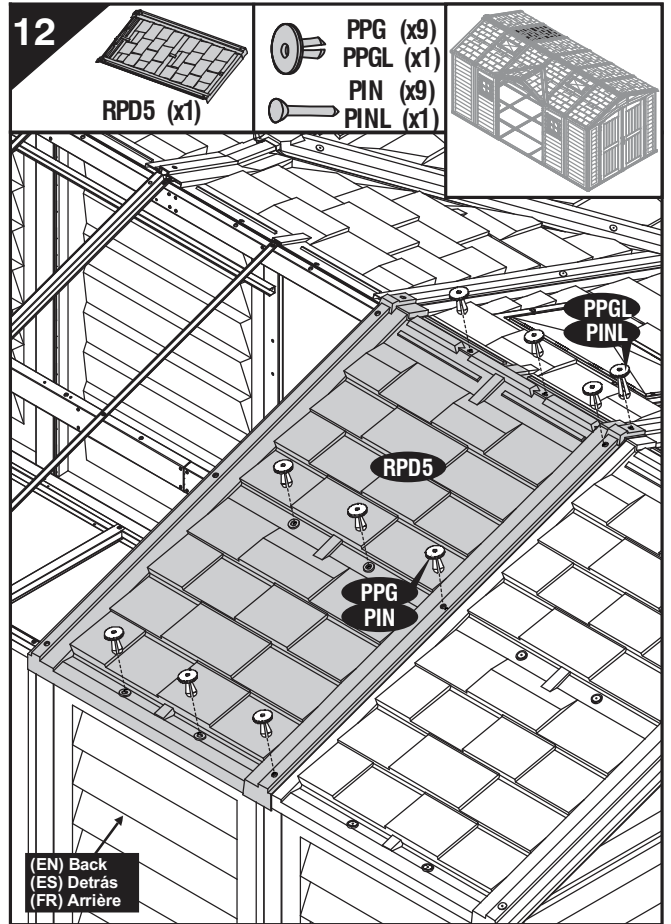
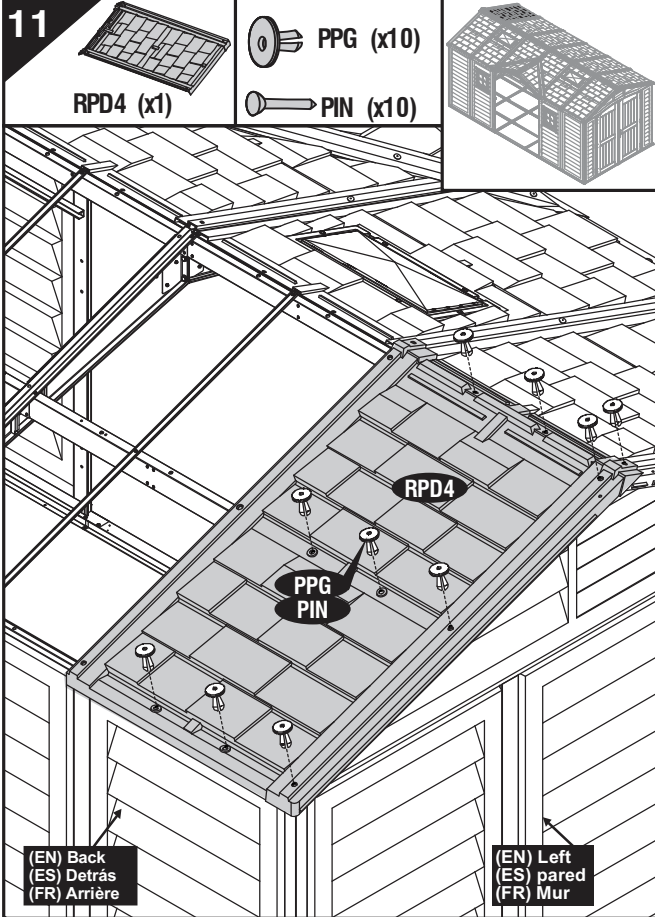

15



RPD5 (x1)



PPG (x9)

PPGL (x1)

PIN (x9)

PINL (x1)

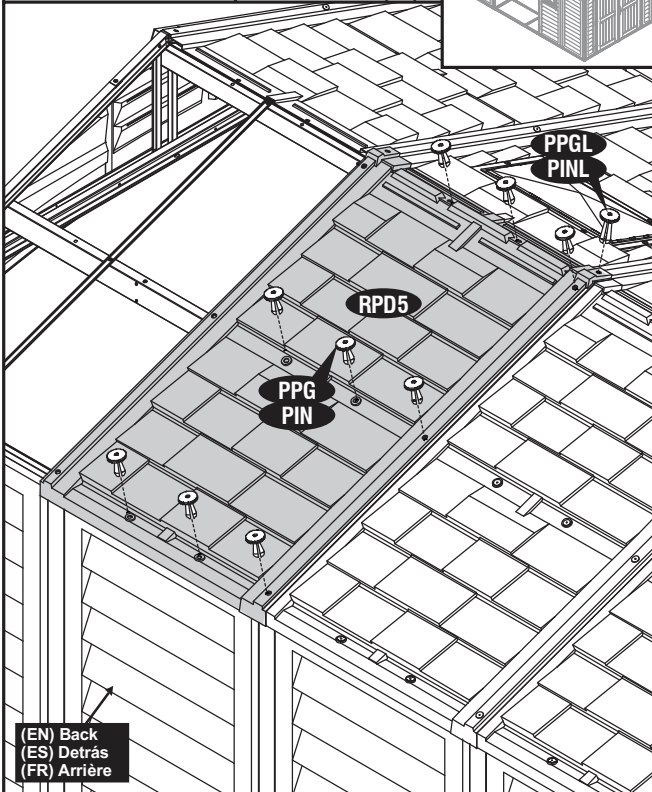
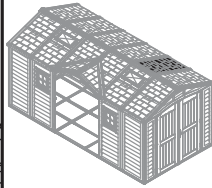

(EN) Back  
(ES) Detrás  
(FR) Arrière

16



RPD6 (x1)



PPG (x13)

PPGL (x1)

PIN (x13)

PINL (x1)

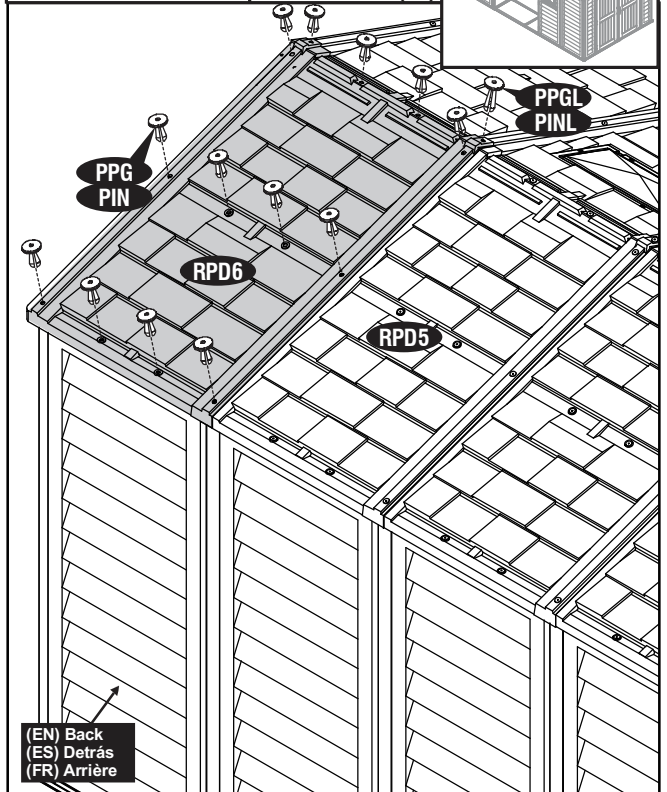
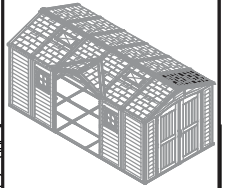

(EN) Back  
(ES) Detrás  
(FR) Arrière

17

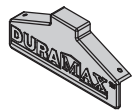

EC2 (x3)



FP (x6)

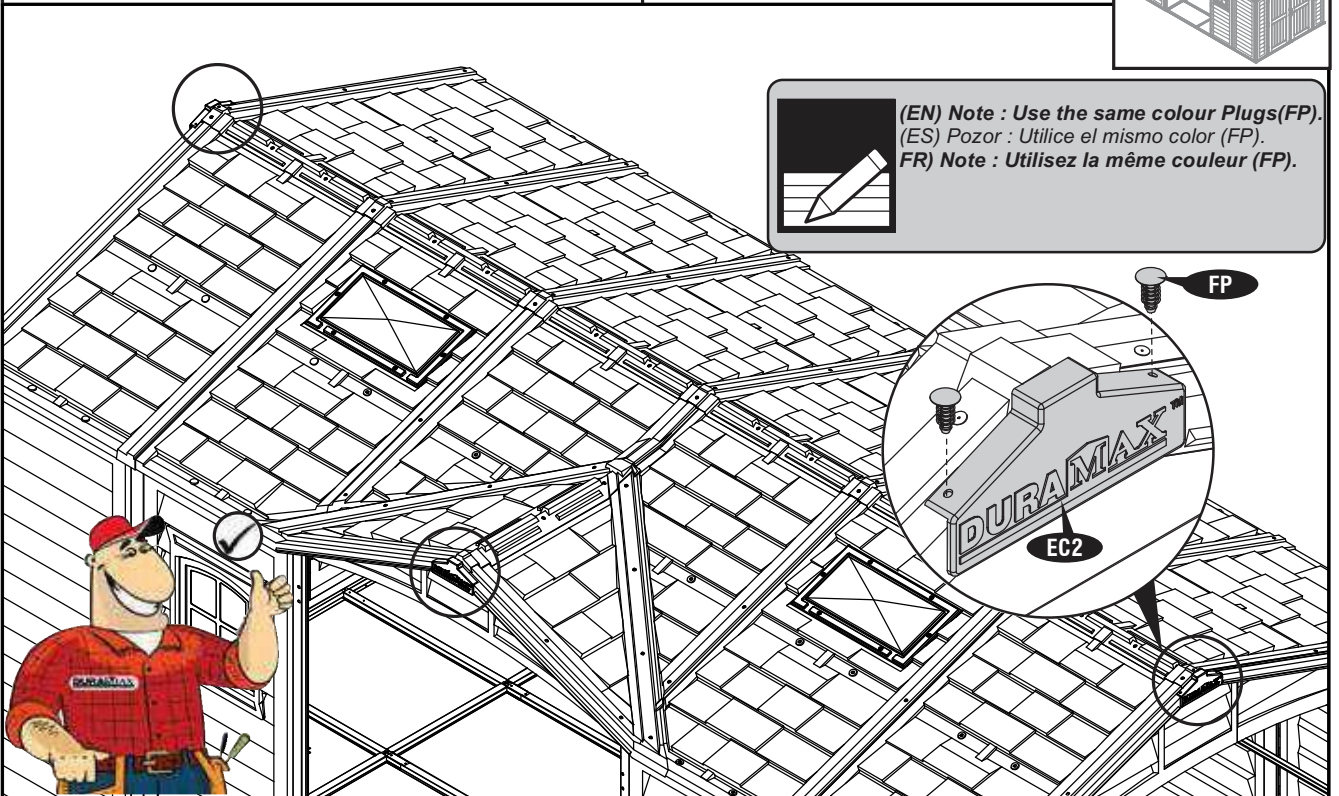
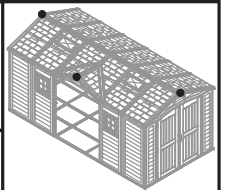

(EN) Note : Use the same colour Plugs(FP).  
(ES) Pozor : Utilice el mismo color (FP).  
(FR) Note : Utilisez la même couleur (FP).

70

(EN) IMPORTANT: USE HAND GLOVES TO PREVENT INJURY.  
(FR) IMPORTANT: UTILISER LES GANTS POUR PREVENIR LES ACCIDENTS.

(ES) IMPORTANTE: GUANTES DE MANO DE USO PARA PREVENIR LA HERIDA.





**7** (EN) Door  
(ES) La puerta  
(FR) Porte

(EN) Parts needed  
(ES) Las partes necesitaron  
(FR) Pièces nécessaires

(EN)CODE (ES)CODE (FR)CODE	(EN)QTY (ES)QTY (FR)QTÉ	(EN)CODE (ES)CODE (FR)CODE	(EN)QTY (ES)QTY (FR)QTÉ
DLG	2	L	2
DRG	2	R	2
LH†	6	SGC1	56
RH†	6	PW	56

**1**

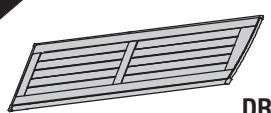

DRG (x2)

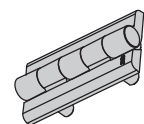

RH† (x4)



SGC1 (x8)



PW (x8)

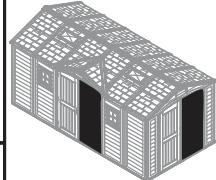

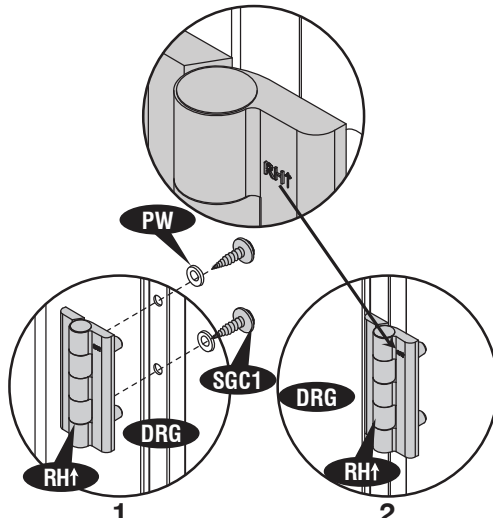

1                      2

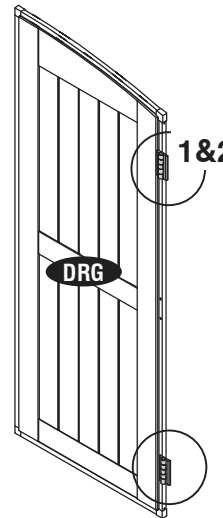

(EN) Right Door  
(ES) La Puerta correcta  
(FR) Porte Droite

x2

**2**

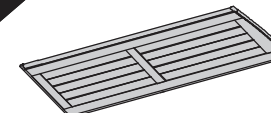

DLG (x2)

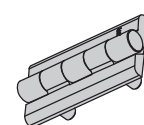

LH† (x4)



SGC1 (x8)



PW (x8)

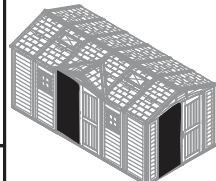

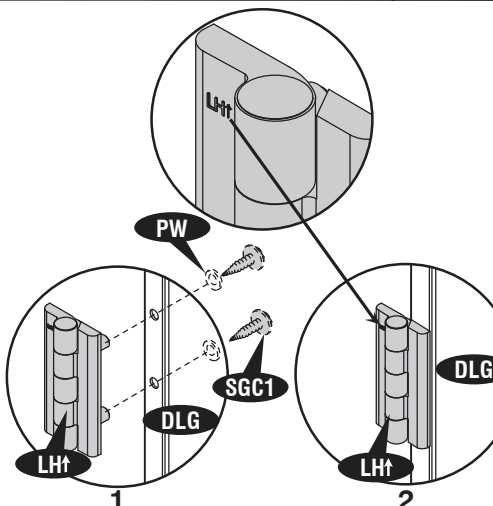

1                      2

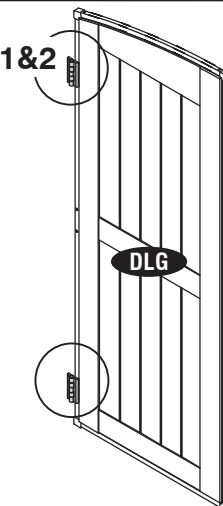

(EN) Left Door  
(ES) La Puerta izquierda  
(FR) Po rte Gauche

x2

**3**

DLG (x1)      DRG (x1)

SGC1 (x8)  
PW (x8)

DRG      RH↑      CLA1      SGC1      PW

1

DRG      RH↑      CLA1

2

CLA4      DLG      DRG      CLA1      1&2

(EN) Right  
(ES) Correcta  
(FR) Partie droite

**4**

LH↑ (x1)      RH↑ (x1)

SGC1 (x8)  
PW (x8)

DRG      RH↑      CLA1      SGC1      PW

1

DRG      RH↑      CLA1

2

CLA4      DLG      DRG      CLA1      1&2

(EN) Right  
(ES) Correcta  
(FR) Partie droite

**5**

L (x1)      R (x1)      SGC1 (x4)      PW (x4)

1      2

L      R

(EN) Right  
(ES) Correcta  
(FR) Partie droite

**6**

DLG (x1)      DRG (x1)      SGC1 (x8)      PW (x8)

DLG      DRG

1      2

DRG      RH↑      SGC1      CLG1      PW

DRG      RH↑      CLG1

CLG2      DLG      DRG      CLG1

1&2

(EN) Front  
(ES) Frente  
(FR) Avant

**7**

LH† (x1)      RH† (x1)      SGC1 (x8)      PW (x8)

DRG      CLG1      SGC1      PW

RH†      1

DRG      CLG1      RH†

2

DLG      DRG      1&2

(EN) Front  
(ES) Frente  
(FR) Avant

**8**

L (x1)      R (x1)      SGC1 (x4)      PW (x4)

SGC1      SGC1      R

PW      PW

1      2

L      R

DRG      DRG

1      2

(EN) Front  
(ES) Frente  
(FR) Avant



**(EN) Shed Assembly on Concrete Foundation**  
**(ES) Montaje de galpón en concreto de la Fundación**  
**(FR) Assemblée de hangar sur une fondation en béton**

**(EN) Parts needed**  
**(ES) Las partes necesarias**  
**(FR) Pièces nécessaires**

(EN)CODE	(EN)QTY
(ES)CODE	(ES)QTY
(FR)CODE	(FR)QTÉ
S2	28
F1	28

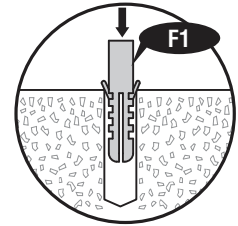
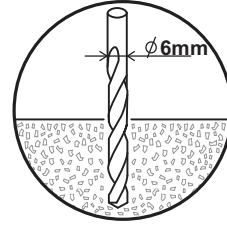

**1**

(EN) Outside  
 (ES) Exterior  
 (FR) Extérieur

**2**

(EN) Base 'U' channel  
 (ES) Base canal 'U'  
 (FR) Profilé en U

(EN) Foundation Frame  
 (ES) Marco de fundación  
 (FR) Cadre de la fondation

**3**

**1**

**1,2&3**

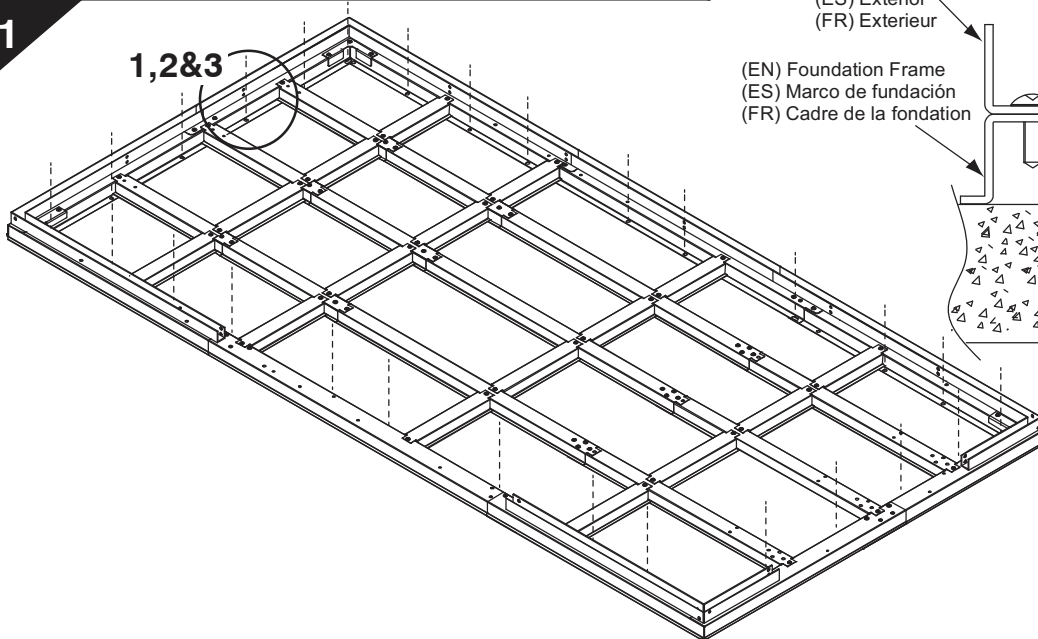

**(EN) Note:** To ensure that your shed will withstand high winds, you need to anchor on the concrete foundation. A concrete pad or large size concrete patio stone squares is recommended for suitable floor base. Make sure it is firm and level and will allow drainage away from the site. Make a level concrete foundation, that has an outside dimension of 98 1/4" x 191 5/8" (2497mm x 4867mm). For a concrete pad base, prepare a level bed for a firm footing layer of crushed stone. The concrete pad should then be poured to a thickness of 4 inches (100mm) to 5 inches (125mm). Allow to dry thoroughly for at least 48 hours.

**Manufacturer is not responsible for the choice and construction of the foundation.**

**Align the shed, mark the concrete at the holes in the Foundation Profiles and drill concrete with suitable concrete bit to accept Dia 6mm wall plug.**

**(ES) Nota:** Para asegurar que su vertiente soportará vientos, usted necesitó anclar en la Fundación concreta. Una plataforma de concreto o un plazas piedra de hormigón patio de gran tamaño se recomienda para base de piso adecuado. Asegúrese de que esté firme y nivelado y permitirá el drenaje lejos del sitio. Hacer la base de una nivel base de hormigón, que tiene una dimensión exterior de 98 1/4" x 191 5/8" (2497mm x 4867mm). Para una plataforma de concreto, preparar una cama de nivel para una capa de apoyo firme de piedra machacada. La plataforma de concreto debe ser vertida luego en un espesor de 4 pulgadas (100mm) a 5 pulgadas (125mm). Deje para secar durante al menos 48 horas. Fabricante no es responsable de la elección y la construcción de la Fundación.

**Alinee el cobertizo, Marcar el concreto en los agujeros en la base y perforar concreto con poco cemento adecuado para aceptar enchufe de pared de 6 mm de diámetro.**

**(FR) Note:** Pour vous assurer que votre abri résistera à des vents violents, vous aviez besoin d'ancrer sur les fondations en béton.

**Une dalle de béton ou une pierre carrés de taille grand patio en béton est recommandée pour la base convenable étage. Assurez-vous qu'il est ferme et de niveau et permettra de drainage en dehors du site. Faire une fondation en béton niveau, qui a une dimension extérieure de 98 1/4" x 191 5/8" (2497mm x 4867mm).**

**Pour une dalle de béton de base, préparez un lit de niveau pour une couche de base solide de pierres concassées. On verse ensuite la dalle en béton d'une épaisseur de 4 pouces (100mm) à 5 pouces (125mm). Laisser pour sécher complètement pendant au moins 48 heures. Référence du fabricant n'est pas responsable du choix et la construction de la Fondation.**

**Aligner le hangar, Marquer le béton dans les trous de la base et percer le béton avec foret à béton adapté à accepter Dia prise murale 6mm.**

**(EN) Floor Options**  
**(ES) Opción de piso**  
**(FR) Option plancher**

**1**

**(EN) Plywood (Not included)**  
**(ES) Contrachapado (No incluido)**  
**(FR) Contreplaqué (Non fournies avec l'abri)**

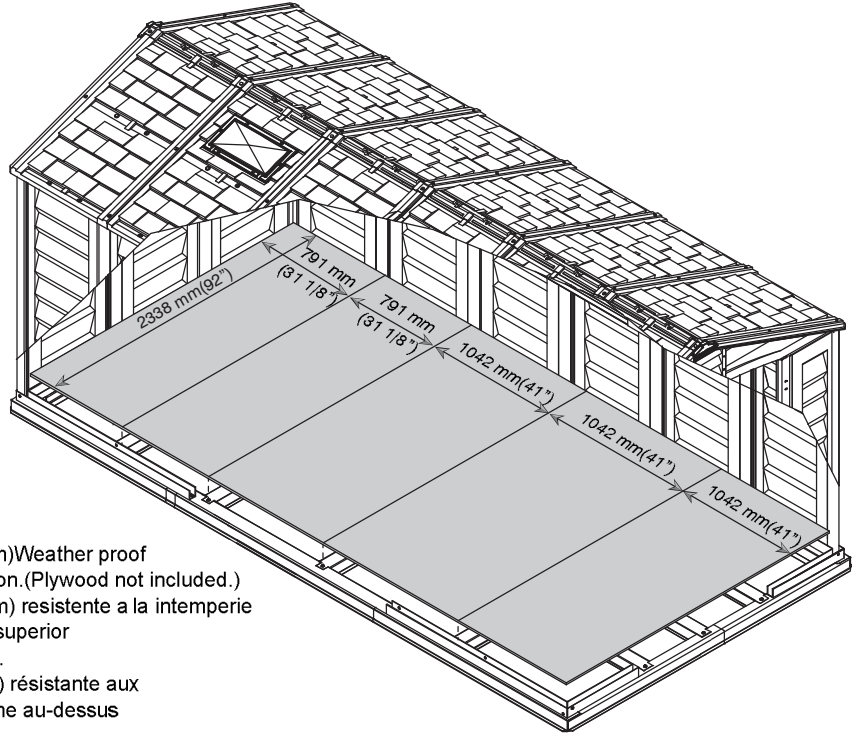

**(EN)** Place the Exterior Grade (CDX) - 3/4" (19mm) Weather proof Marine grade plywood on top of the foundation. (Plywood not included.)  
**(ES)** coloque el grado exterior (CDX) -3/4 "(19 mm) resistente a la intemperie contrachapado marino de grado en la parte superior de la fundación (contrachapado no incluido).  
**(FR)** placer le grade extérieur (CDX) -3/4 "(19mm) résistante aux intempéries de contreplaqué de qualité marine au-dessus de la fondation. (contreplaqué non inclus)

**2**

**(EN) Concrete Floor (Not Included)**  
**(ES) Piso de concreto (no incluido)**  
**(FR) Plancher de béton (non inclus)**

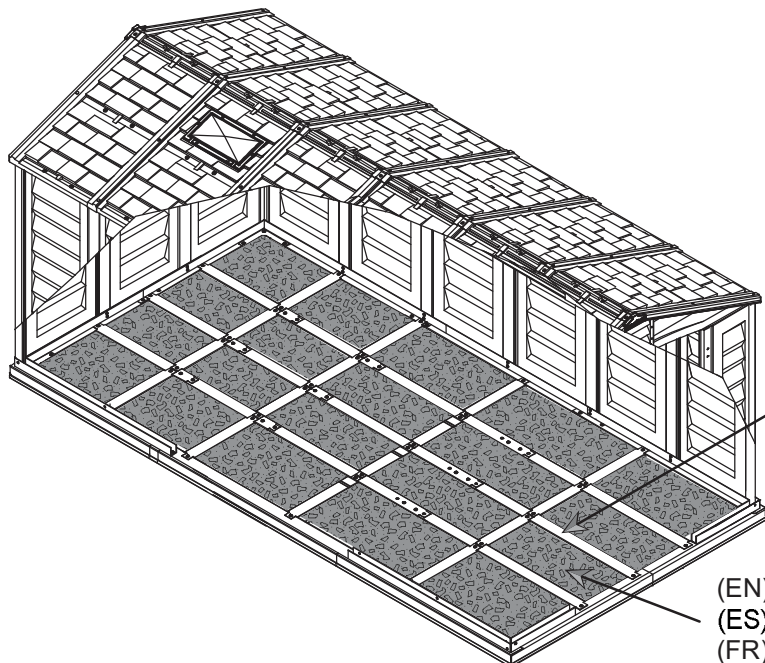

**(EN)** Concrete to be filled up to this level  
**(ES)** Hormigón para ser lled hasta este nivel  
**(FR)** Béton pour être lled jusqu'à ce niveau

**(EN)** Concrete  
**(ES)** Hormigón  
**(FR)** Béton





(EN) Apply silicone around the perimeter of the base 'U' channel. Seal the corners, joints and base of door column. This is optional and should be done for heavy rain areas if needed.

(ES) Pozor : Aplicar silicona alrededor del perímetro del canal "U" de la base. Selle las esquinas, juntas y la base de la columna de la puerta.

Esto es opcional y se debe hacer para zonas de fuertes lluvias, si es necesario.

(FR) Appliquez de la silicone sur le pourtour du canal de 'U' de la base. Scellez les coins, les joints et la base de la colonne de la porte. Ce n'est pas obligatoire et cette opération doit être réalisée si besoin dans des zones de fortes pluies.

(EN) Base 'U' channel  
(ES) Base canal 'U'  
(FR) Profilé en 'U'

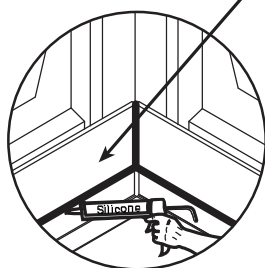

1

(EN) Column  
(ES) Columna  
(FR) Cornière

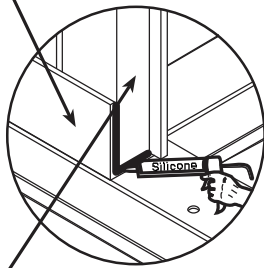

2

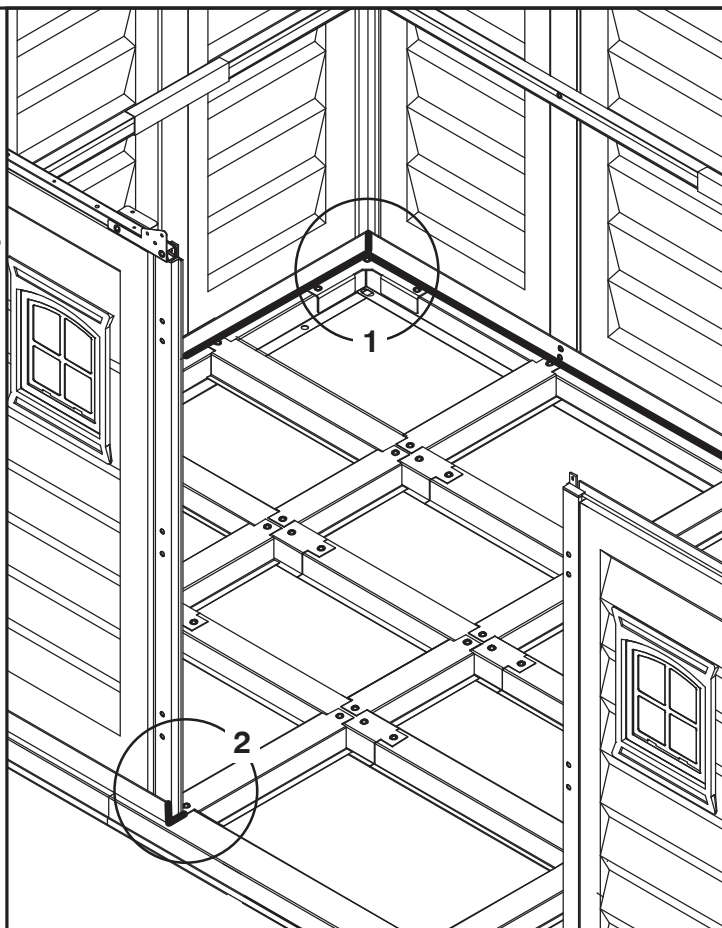

(EN) For heavy rain areas, you can fix a weather strip at the bottom of the door. This is optional and the part is not included.

(ES) Pozor : Aplicar silicona alrededor del perímetro del canal "U" de la base. Selle las esquinas, juntas y la base de la columna de la puerta.

Esto es opcional y se debe hacer para zonas de fuertes lluvias, si es necesario.

(FR) Pour les zones de fortes pluies, vous pouvez fixer un coupe-froid au bas de la porte. Cette étape est facultative et la partie n'est pas incluse.

(EN) Door Assembly  
(ES) Montaje de la puerta  
(FR) Assemblage de la porte

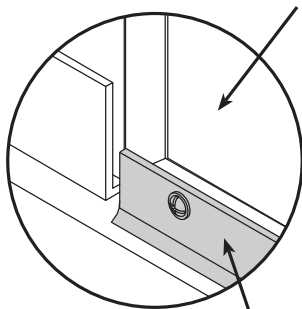

(EN) Weather Strip Seal  
(ES) Franja de Sello contra el clima  
(FR) Joint coupe-froid

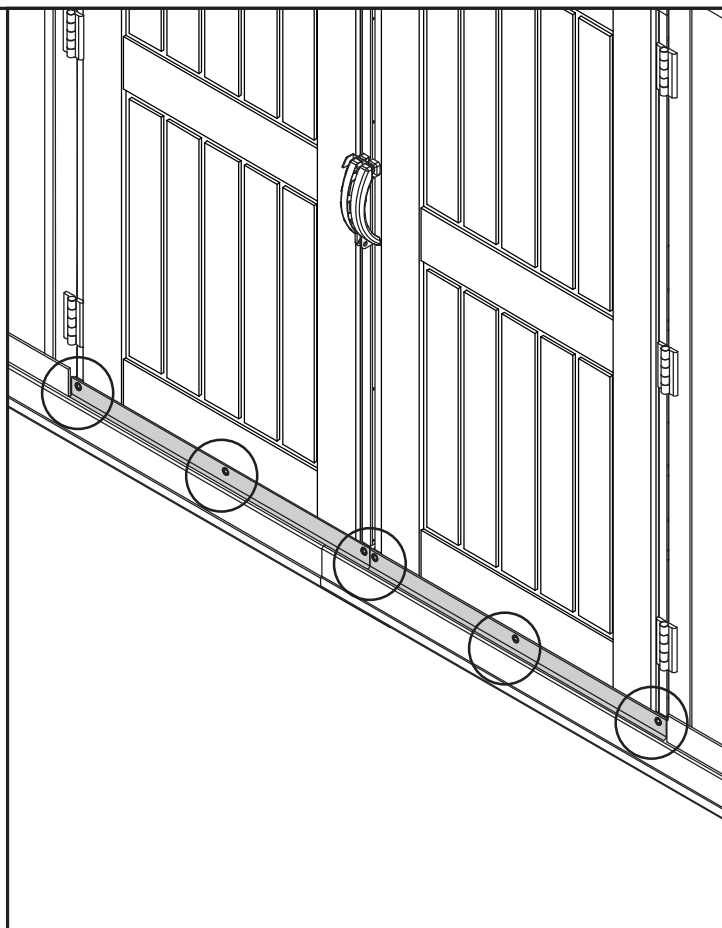



**(EN) High wind area installation instructions**  
**(ES) Instrucciones de instalación de la zona con fuertes vientos**  
**(FR) Instructions pour une installation dans des zones de vent violent**

**(EN) To ensure that your shed withstands high winds, you will need the following reinforcement.**  
**(ES) Para asegurarse de que su cubierta resiste a vientos fuertes, se necesita el siguiente refuerzo**  
**(FR) Pour être sûr que votre abri supportera des vents violents, vous devrez vous équiper des renforts suivants**

<b>(EN) Parts needed (not included) :</b>			<b>(ES) Piezas necesarias (no incluidos):</b>			<b>(FR) Pièces nécessaires (non fournies avec l'abri):</b>		
CODE	DESCRIPTION	QTY	CODE	DESCRIPCIÓN	QTY	CODE	DESCRIPTION	QTE
S4	Dia. 4.2 x 16mm. (5/32" x 5/8") Sheet Metal Screw	60	S4	Dia. 4.2 x 16mm. (5/32" x 5/8") Hoja de tornillo de metal	60	S4	DIA. 4,2 x 16 mm. (5/32" x 5/8") VIS A TOILE	60

**1**

**(EN)** To ensure that your shed will withstand high winds, you need to anchor on the concrete foundation. Align the shed, mark the concrete at the holes in the Foundation Profiles and drill concrete with suitable concrete bit to accept Dia 6mm wall plug. (Follow the assembly step in page 75).

**(ES)** Para asegurarse de que su nave puede soportar fuertes vientos, lo necesario para anclar en el concreto foundation. Align el cobertizo, marcar el hormigón en los agujeros de los perfiles de cimentación y perforación de hormigón con hormigón poco adecuada para aceptar el enchufe de pared de diámetro 6 mm. (Sigue la etapa de montaje en la página 75).

**(FR)** Pour vous assurer que votre hangar va résister aux vents violents, il fallait ancrer sur le foundation. Align béton du hangar, marquer le béton au niveau des trous dans les profils de fondation et forage de béton avec foret à béton adapté à accepter diamètre prise murale de 6 mm. (Suivez l'étape d'assemblage en pages 75).

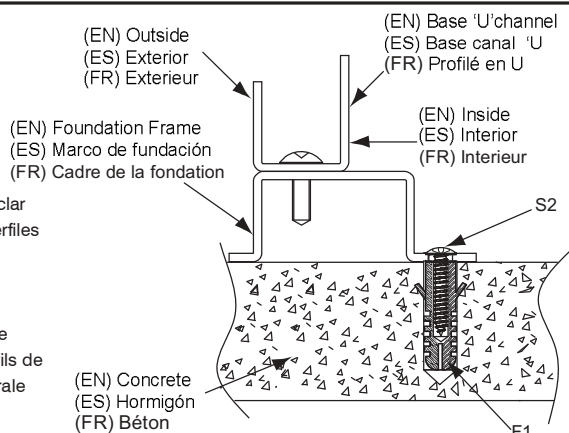

**2**

**(EN)** Attach each side panel (WPA1↑, WPA2↑, WPB1↑) on the bottom to the Base U-channel. Using a dia. 3mm (1/8") drill with a power drill, make two equal distance holes on the Base U-channel through the Side Panel. Drive a self tapping screw (S4) through the Base U-channel to the Side Panel. Repeat this for every Side Panel. See blowup.

**(ES)** Fije cada panel lateral (WPA1↑, WPA2↑, WPB1↑) en la parte inferior a la base U-canal. Usando un día. 3 mm (1/8 ") perfore con un taladro eléctrico, hacer dos agujeros a la misma distancia de la Base del canal U- a través del panel lateral. Introduza un tornillo auto-roscante (S4) a través de la Base de canal U- del panel lateral. Repita esto para cada panel lateral. Ver ampliación.

**(FR)** Attachez chaque panneau latéral (WPA1↑, WPA2↑, WPB1↑) sur le bas des profilés U. En utilisant un foret de 3mm de dia. avec une perceuse électrique, faites deux trous à à égale distance sur le profilé U, à travers le Panneau Latéral. Enfoncez une vis auto-fôrante (S4) à travers le profilé U au Panneau Latéral. Répétez ceci pour chaque panneau latéral. Voir schéma ci-dessous.

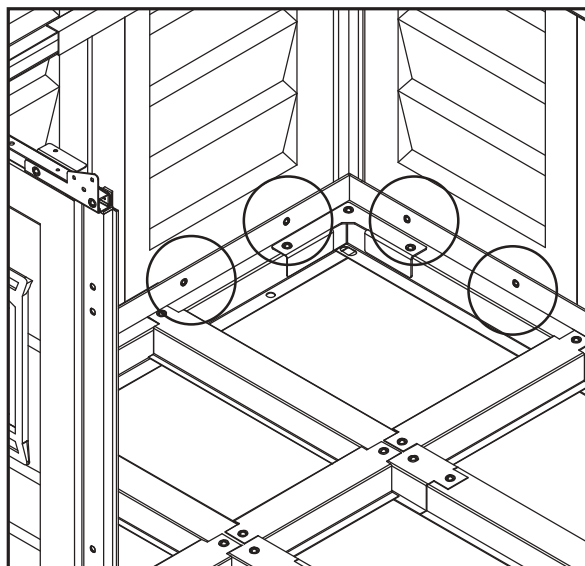
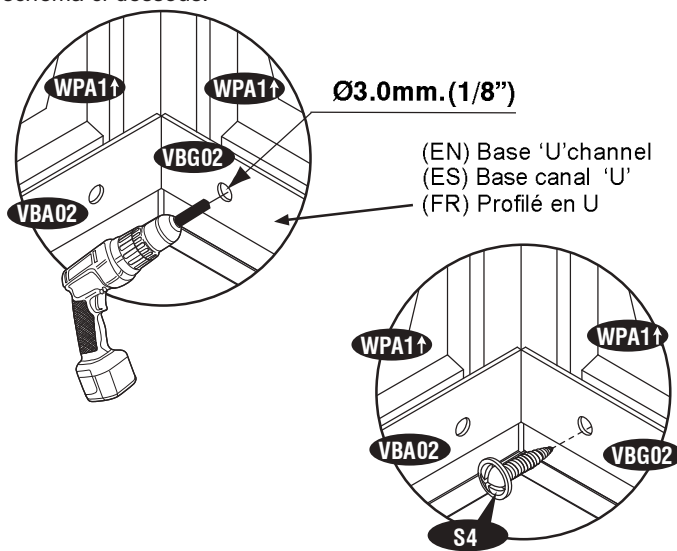



3

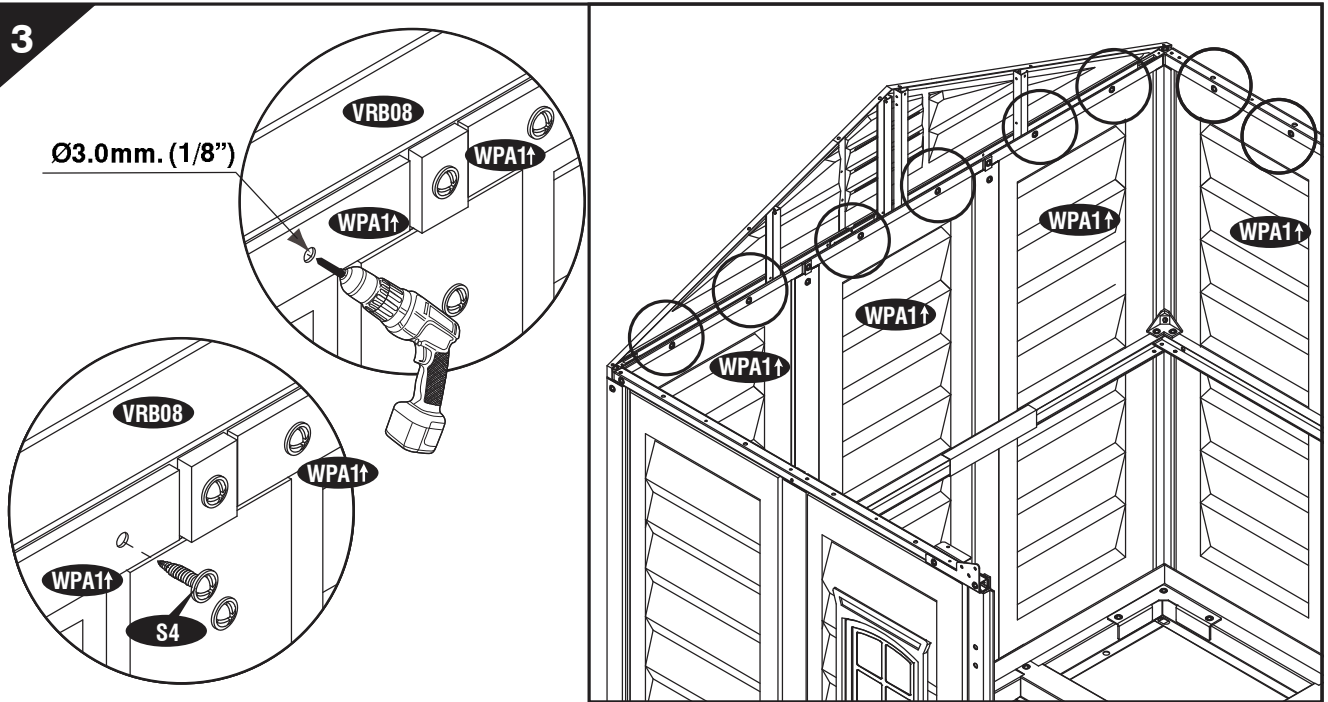

- (EN) Attach each Side Panel (**WPA1↑, WPA2↑ & WPB1↑**) on top to the Roof Structure (**VRB01, VRB07, VRB08, VRA06 & VRG03**). Using a dia. 3mm (1/8") drill with a power drill, make two equal distance holes on the Side Panel through the Roof Structure. Drive a self tapping screw (**S4**) through the Side Panel to the Roof Structure. Repeat this for every Side Panel. See blowup.
- (ES) Fije cada panel lateral (**WPA1↑, WPA2↑ & WPB1↑**) en la parte superior de la estructura del tejado (**VRB01, VRB07, VRB08, VRA06 & VRG03**). Usando un día. 3 mm (1/8 ") perfore con un taladro eléctrico, hacer dos agujeros a la misma distancia en el panel lateral a través de la estructura del techo. Introduzca un tornillo auto-roscante (**S4**) a través del panel lateral a la estructura del techo. Repita esto para cada panel lateral. Ver ampliación.
- (FR) Fixez chaque panneau latéral (**WPA1↑, WPA2↑ & WPB1↑**) au-dessus de la structure de toit (**VRB01, VRB07, VRB08, VRA06 & VRG03**). Avec un foret de 3 mm (1/8") et une perceuse électrique, percez deux trous à égale distance sur le panneau latéral dans la structure de toit. Insérez une vis auto-fôrante (**S4**) à travers le panneau latéral dans la structure de toit. Répétez cette opération avec chaque panneau latéral. Voir le zoom ci-contre.

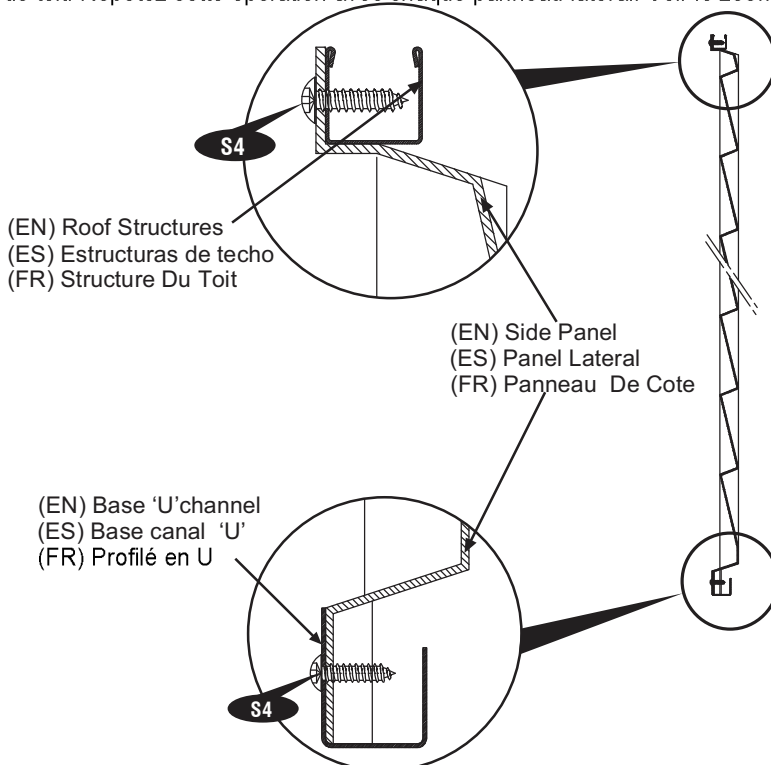

**(EN) Important Warranty Information**

**(ES) Información importante sobre la garantía**

**(FR) Informations Importantes Concernant La Garantie**

**(EN)** *The 'DURAMAX' shed has been tested and passed high wind loads in a controlled laboratory environment when installed with the high wind installation guidelines. Natural high wind areas create wind at unpredictable speeds that are very difficult to capture accurately by location. As such we cannot guarantee the performance of the shed in these extreme situations*

**(ES)** *El cobertizo ' DURAMAX ' ha sido probado y aprobado cargas de viento en un entorno controlado de laboratorio cuando se instala con las pautas de instalación de vientos fuertes . Espacios naturales de vientos crean viento a velocidades impredecibles que son muy difíciles de capturar con precisión la ubicación. Como tal , no podemos garantizar el funcionamiento de la nave en*

**(FR)** *Le hangar ' DURAMAX ' a été testé et passé des charges de vent élevées dans un environnement de laboratoire contrôlé lorsqu'il est installé avec les directives d'installation de haute vent . Naturelles, les zones de vents forts créent vent à des vitesses imprévisibles qui sont très difficiles à saisir avec précision par emplacement . En tant que tel , nous ne pouvons pas garantir la performance de la foule dans ces situations*

**(EN)** *“We recommend to clear snow from the Roof top after each Snowfall.”  
A snow depth of more than 10 cm can become hazardous!*

**(ES)** *“Se recomienda limpiar la nieve de la azotea después de ca da nevada.”  
Una profundidad de nieve de más de 10 cm puede llegar a ser peligrosa!*

**(FR)** *“Nous recommandons d'enlever la neige du Toit après chaque Enneigement.”  
Une neige de plus de 10 cm peut devenir dangereux! page77*

**(EN)** *“For dismantling the Shed, Customer has to follow instructions manual in reverse direction.”*

**(ES)** *“Para el desmantelamiento de la nave, cliente tiene que seguir instrucciones en sentido contrario”.*

**(FR)** *“Pour le démantèlement du hangar, client doit suivre le manuel d'instructions dans le sens inverse.”*

**(EN) ADDITIONAL ACCESSORIES AVAILABLE (Not included).**  
**(ES) ACCESORIOS ADICIONALES DISPONIBLES (No incluidos).**  
**(FR) ACCESSOIRES ADDITIONNELS DISPONIBLES (Non fournies avec l'abri).**

*(EN) These accessories are required in case of heavy snow or high wind areas.  
Please choose relevant accessories according to your needs.*  
*(ES) Estos accesorios son requeridas en caso de fuertes nevadas o zonas de alto viento.  
Por favor, elija los accesorios pertinentes de acuerdo a sus necesidades.*  
*(FR) Ces accessoires sont exigés en cas de zones neigeuse ou venteuse.  
Veuillez choisir les accessoires appropriés selon vos besoins.*

**(EN) ANCHOR KIT (Soil)**  
**(ES) KIT DE ANCLAJE (Suelo)**  
**(FR) KIT d'ancrage (au sol)**

(EN) Wire rope with twist augers for sheds installed with foundation (Wood / Metal) on soil.  
**For heavy wind area.**  
(ES) De cable metálico con barrenas helicoidales para cobertizos instalados con la fundación (Metal y madera) en el suelo.  
**Para el área del fuerte viento.**  
(FR) Sardine auto-forante pour abri installé avec fondation (en métal / en bois) directement sur le sol.  
**Pour les zones venteuses.**

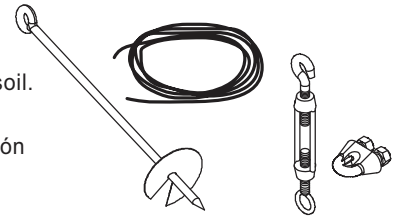

**(EN) ANCHOR KIT (Concrete)**  
**(ES) KIT DE ANCLAJE (Hormigón)**  
**(FR) KIT d'ancrage (Béton)**

(EN) Eye bolt with wire rope for sheds installed with foundation (Wood / Metal) on concrete.  
**For heavy wind area.**  
(ES) Perno de Ojo con el cable de alambre para las vertientes instalado con la fundación (Metal y madera) en el hormigón.  
**Para el área del fuerte viento.**  
(FR) Boulon à oiellet avec fil en fer pour abri installé avec fondation (en métal / en bois) sur le béton.  
**Pour les zones venteuses.**  
**Para el área del fuerte viento.**

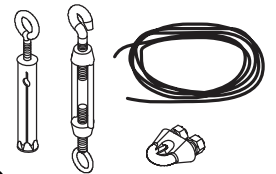

**(EN) SHELF KIT**  
**(ES) KIT ESTANTE**  
**(FR) KIT D'ÉTAGÈRE**

(EN) Easy mounting system on the middle column.  
6 inch wide reinforced PVC shelf with end caps.  
(ES) Fácilsistema de montaje en la columnacentral.  
Estante de PVC reforzado con tapas de 6 pulgadas de ancho.  
(FR) Système facile de montage d'un kit d'étagère sur les cornières du milieu.  
Etagère de 15 cm de large en PVC renforcé.

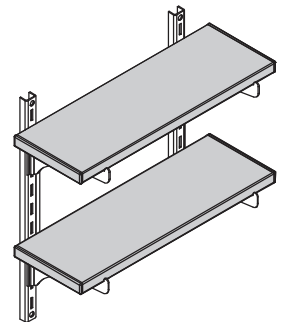



**(EN) Congratulations!**

**(EN) We hope you enjoy your DuraMax Storage Shed!**

**(ES) Felicidades!**

**(ES) Esperamos que disfrute su cobertizo de almacenaje para DuraMax!**

**(FR) Félicitations !**

**(FR) Nous espérons que vous apprécierez votre cabanon de DuraMax!**