

# 12' x 24' MERIDIAN WOOD GAZEBO

with ALUMINUM ROOF

## Installation and Operating Instructions – YM11937



IMPORTANT, RETAIN FOR FUTURE REFERENCE: READ CAREFULLY

Revised 09-23-2021

**YARDISTRY**<sup>®</sup>

Yardistry – North America  
Toll Free Customer Support:  
1.888.509.4382  
info@yardistrystructures.com  
www.yardistrystructures.com

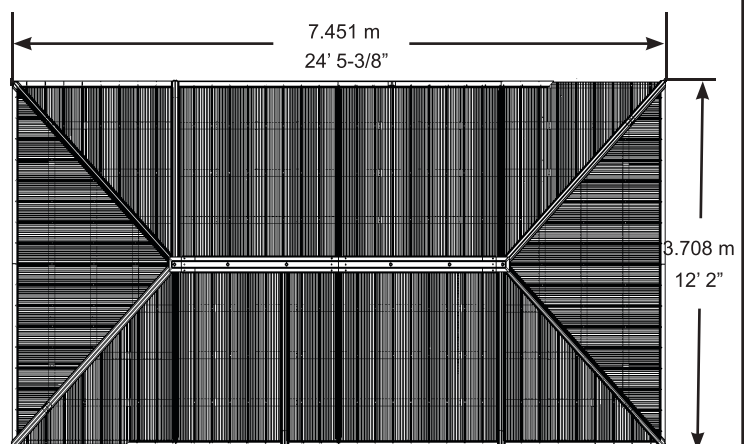

HEIGHT:  
3.099 m / 10'2"

## **Important Safety Notice!**

Yardistry components are intended for privacy, decorative and ornamental use only.

### **Product is NOT INTENDED for the following:**

- A safety barrier to prevent unsupervised access to pools, hot tubs, spas or ponds.
- As load bearing support for a building, structure, heavy objects or swings.
- Used in structures that trap wind, rain or snow that would create extra load on the product.

### **Accumulated snow must be removed from roof.**

**DO NOT** climb or walk on roof for any reason.

**Permanent structures may require a building permit.** As the purchaser and or installer of this product you are advised to consult local planning, zoning and building inspection departments for guidance on applicable building codes and/or zoning requirements.

**Wood is NOT flame retardant and will burn.** Grills, fire pits and chimineas are a fire hazard if placed too close to a Yardistry structure. Consult user's manual of the grill, fire pit or chimenea for safe distances from combustible materials.

**Wear gloves to avoid injury** from possible sharp edges of individual elements before assembly.

**During installation, follow all safety warnings provided with your tools and use OSHA approved safety glasses.** Some structures may require two or more people to install safely.

**Check for underground utilities before digging or driving stakes into the ground!**

**It is important during assembly to closely follow the instructions,** complete the assembly on a solid level surface and that you follow the instruction to square up, level and anchor the structure, this will reduce the gap at wood connections during assembly.

## **General Information**

**General Information:** Wood components are manufactured with Cedar (C. Lanceolata) which is protected with factory applied water-based stain. Knots, small checks (cracks) and weathering are naturally occurring and do not affect the strength of the product. Annual application of a water-based water repellent sealant or stain is important and will help reduce weathering and checks.

[www.yardistrystructures.com](http://www.yardistrystructures.com)

Questions?

Call toll free or write us at:

1 (888) 509-4382

[info@yardistrystructures.com](mailto:info@yardistrystructures.com)

Patents Pending

# Limited Warranty

Yardistry warrants that this product is free from defect in materials and workmanship for a period of one (1) year from the original date of purchase. In addition, for any product with lumber, all lumber is warranted for five (5) years against rot and decay. This warranty applies to the original owner and registrant and is non-transferable.

Regular maintenance is required to assure the integrity of your product and is a requirement of the warranty. This warranty does not cover any inspection costs.

## **This Limited Warranty does not cover:**

- Labour for replacement of any defective item(s);
- Incidental or consequential damages;
- Cosmetic defects which do not affect performance or integrity;
- Vandalism; improper use or installation; acts of nature, including but not limited to wind, storms, hail, floods, excessive water exposure;
- Minor twisting, warping, checking or any other natural occurring properties of wood that do not affect performance or integrity.

Yardistry products have been designed for safety and quality. Any modifications made to the original product could damage the structural integrity of the product leading to failure and possible injury. Yardistry cannot assume any responsibility for modified products. Furthermore, modification voids any and all warranties.

**This product is warranted for RESIDENTIAL USE ONLY. Yardistry disclaims all other representations and warranties of any kind, express or implied.**

*This Warranty gives you specific legal rights. You may have other rights as well which vary from state to state or province to province. This warranty excludes all consequential damages, however, some states/provinces do not allow the limitation or exclusion of consequential damages, and therefore this limitation may not apply to you.*

# Instructions for Proper Maintenance

Your Yardistry structure is designed and constructed of quality materials. As with all outdoor products it will weather and wear. To maximize the enjoyment, safety and life of your structure it is important that you, the owner, properly maintain it.

## HARDWARE:

- Check metal parts for rust. If found, sand and repaint using a non-lead paint complying with 16 CFR 1303.
- Inspect and tighten all hardware after completion of assembly; after first month of use; and then annually. Do not over-tighten as to cause crushing and splintering of wood.
- Check for sharp edges or protruding screw threads, add washers if required.

## WOOD PARTS:

- Applying a water repellent or stain (water-based) on a yearly basis is important maintenance to maintain maximum life and performance of the product.
- Check all wood members for deterioration, structural damage and splintering. Sand down splinters and replace deteriorated wood members. As with all wood, some checking and small cracks in grain is normal
- Some gapping may occur at some wood connections.

## Assembly Guides

### Tools Required:

- |                              |                      |                           |
|------------------------------|----------------------|---------------------------|
| • Tape Measure               | • 8' Step Ladder x 2 | • 6' Step Ladder x 2      |
| • Carpenters Level           | • Safety Glasses     | • Square                  |
| • Standard or Cordless Drill | • Adult Helper       | • Ratchet                 |
| • Claw Hammer                | • Safety Gloves      | • 7/16, 1/2 & 9/16 Socket |
| • 7/16" & 9/16" Wrench       | • Hard Hat           |                           |

### Symbols:

Throughout these instructions symbols are provided in the top, right-hand corner of the page.



- Use Help, where this is shown, 2, 3 or 4 people are required to safely complete this step. To avoid injury or damage to the assembly make sure to get some help.



- Use a measuring tape to assure proper location



- Pre-drill a pilot hole before fastening screw or lag to prevent splitting of wood.

**If you dispose of your Yardistry structure:** Please disassemble and dispose of your unit so that it does not create any unreasonable hazards at the time it is discarded. Be sure to follow your local waste ordinances.

## Assembly Tips

Following are some helpful tips to make the assembly process smooth and efficient.

### PRE-ASSEMBLIES:

(i.e. Post and Beam Assemblies, Roof Rafter Assembly, etc)

- Work on a raised, solid and flat surface such as, a table or saw horse.
- Keep all connections flush where shown in the instructions.
- When assembling the beams keep parts flat, straight and snug when connecting.

### METAL PARTS:

- Roofing material may have sharp edges, wear safety gloves.
- Remove all plastic covering, on both sides of the metal panels, directly before installing each piece.
- Place roofing material on a non-abrasive surface before and after assembly as it can bend, dent and scratch easily.
- The roofing screws can easily crush the roof panels and roof edges when using a power drill. We recommend hand tightening the roofing screws so they sit snug and tight to the roofing material.

# Permanent Installation Examples

**Note: It is critically important you start with square, solid and level footings, concrete pad or deck to attach your Pergola Room.**

We supply Post Mounts with this structure which gives you the flexibility to permanently install your structure to a pre-existing or new wood or concrete surface.

- The hardware to attach the Post Mount to the structure is included.
- The hardware to mount the structure permanently will need to be purchased separately at your local hardware store.

If you are mounting to concrete footers see below for the correct locations and placement. Please double check for possibility of any underground utilities such as gas, telephone, cable or sprinkler lines.

Following are some examples of how to mount the structure to wood or concrete surfaces.

Refer to your local building and city codes, ordinances, neighbourhood covenants, or height restrictions regarding this type of structure for guidance on acceptable installation requirements.

## Concrete Footer

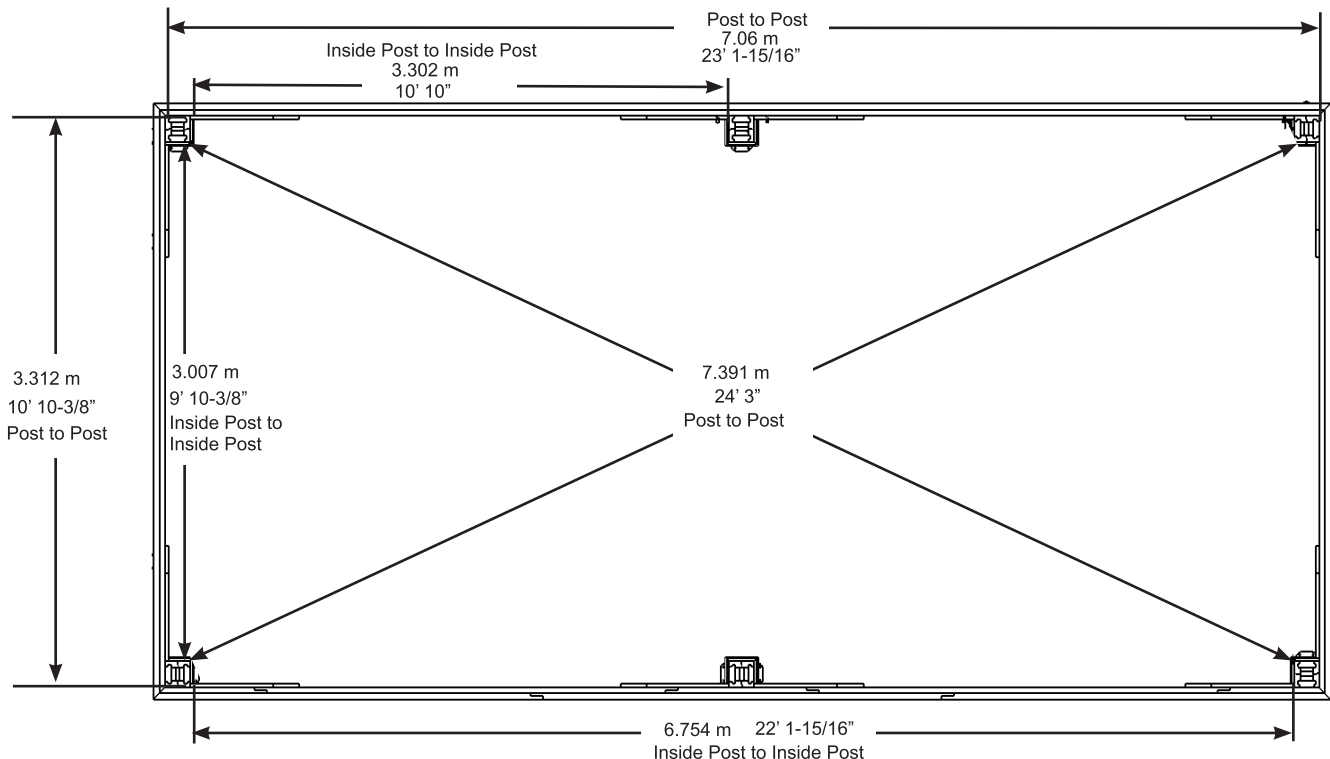
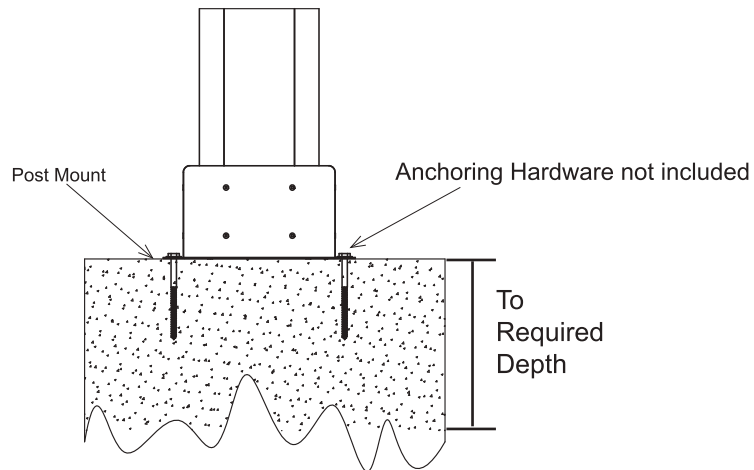

## Permanent Installation Examples cont.

**Concrete Patio [min. 3.616 m x 7.364 m (11' 10-3/8" x 24' 1-15/16")]  
with 15.24 cm (6") clearance on all sides**

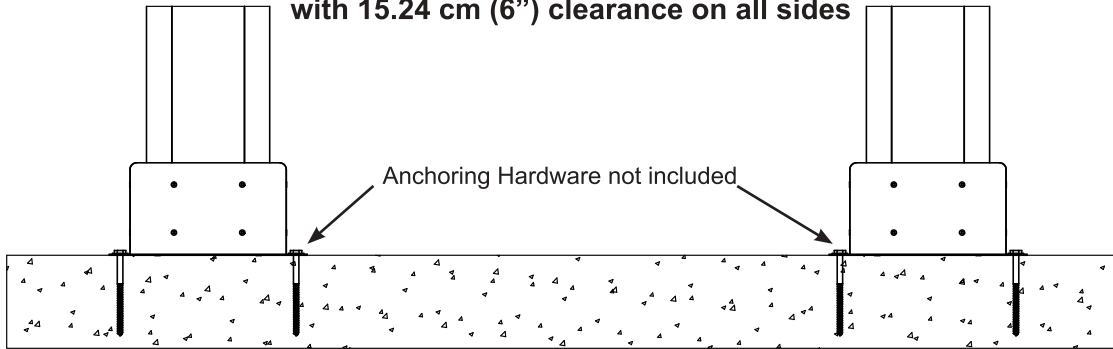

**Wood Deck [min. 3.616 m x 7.364 m (11' 10-3/8" x 24' 1-15/16")]  
with 15.24 cm (6") clearance on all sides**

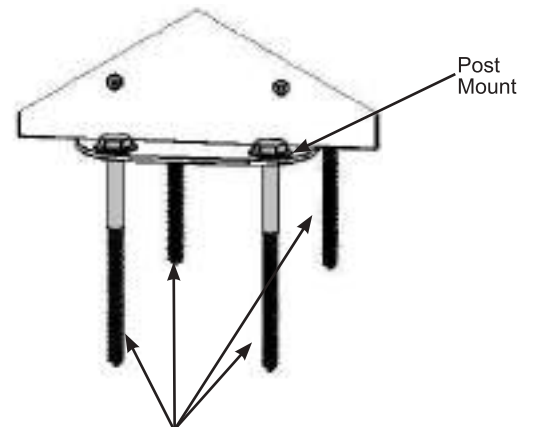
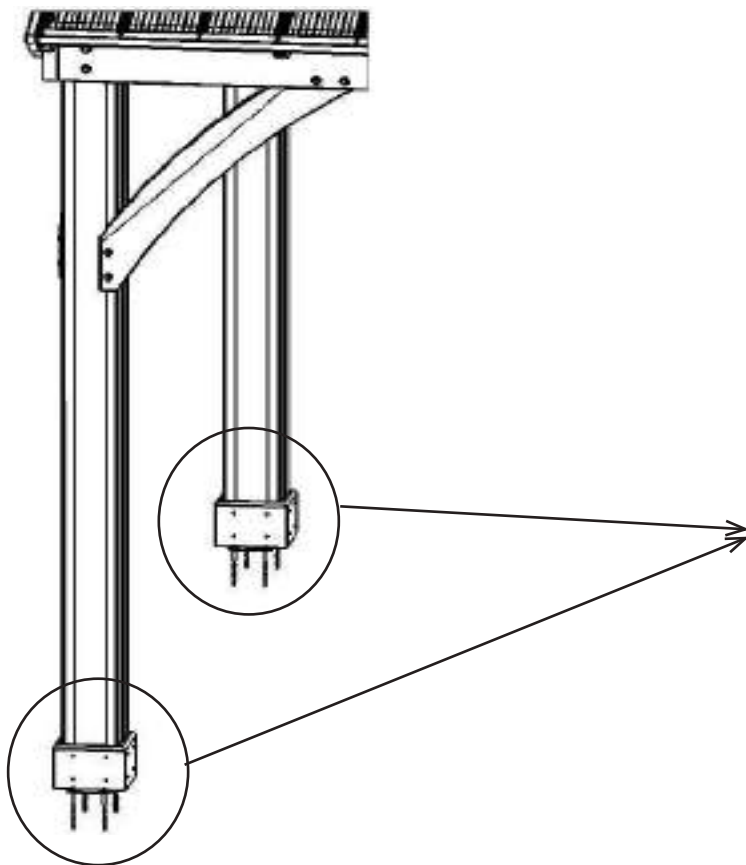
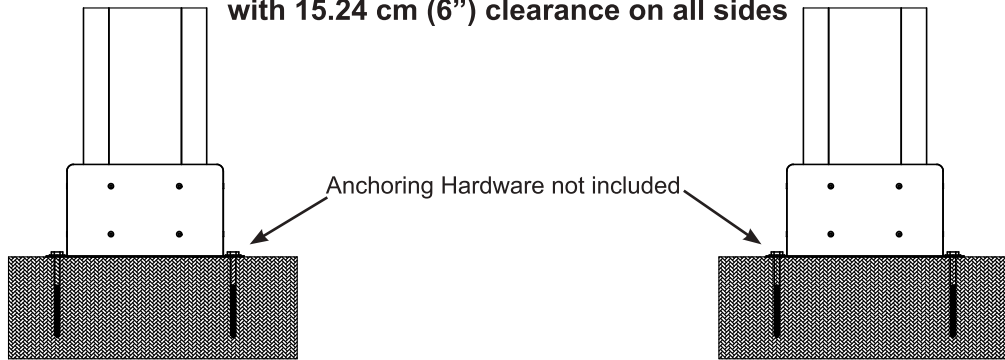

**Post Mounts have a 12.7 mm (1/2") diameter hole for anchoring hardware.**

# Part Identification ( Dimensions are approximate and are shown to assist in the identification of parts for assembly. Actual dimensions may be smaller or larger. )

24pc. (422) Plinth  
190.5mm (7-1/2")

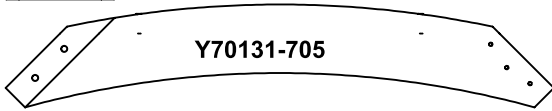
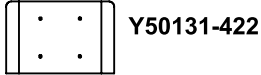

6pc. (705) Gusset RT 1015mm (39-15/16")

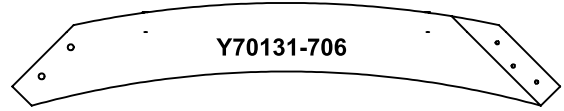

6pc. (706) Gusset LT 1015mm (39-15/16")

2pc. (1003) Beam Short Right 1763.3mm (69-7/16")

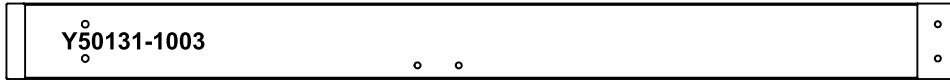

2pc. (1002) Beam Short Left 1763.3mm (69-7/16")

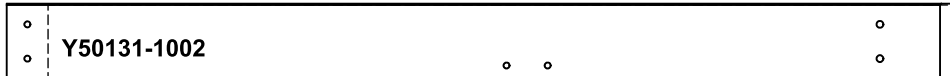

4pc. (1004) Beam Short End 555.4mm (21-7/8")

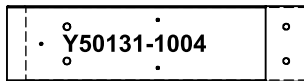

2pc. (1005) Beam Short Centre 2422.1mm (95-3/8")



4pc. (1201) Inside Middle Beam 2590.8mm (102")



2pc. (1196) Beam 2590.8mm (102")



4pc. (1197) Beam End 657.3mm (25-7/8")

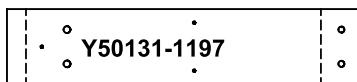

2pc. (1198) Inside Beam 938.1mm (36-15/16")

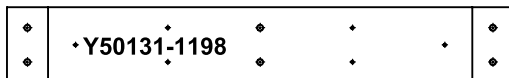

4pc. (1199) Outer Ends 2380.5mm (93-11/16")

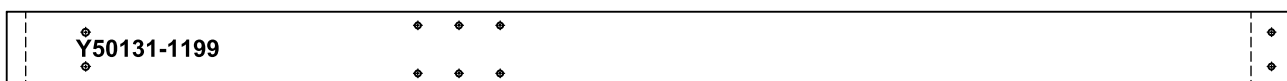

6pc. (696) 6 x 6 Post 2336.8mm (92")

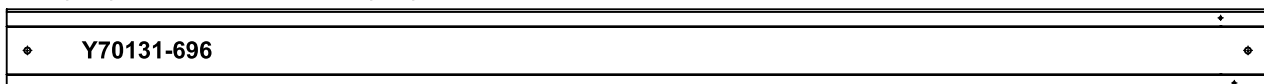



# Part Identification (Dimensions are approximate and are shown to assist in the identification of parts for assembly. Actual dimensions may be smaller or larger.)

4pc. (624) Rafter Corner Left 2597.8mm (102 1/4")

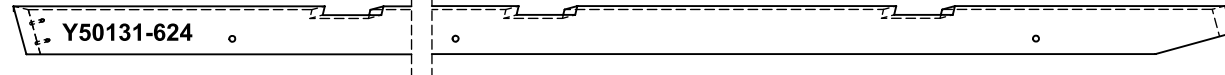

4pc. (623) Rafter Corner Right 2597.8mm (102 1/4")

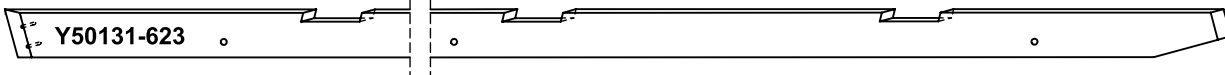

2pc. (627) Fascia Left Short 1855.5mm (73-1/16")

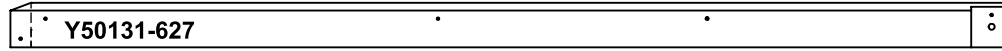

2pc. (628) Fascia Right Short 1855.5mm (73-1/16")

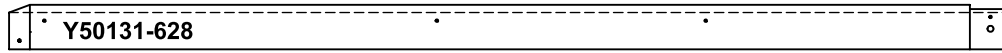

4pc. (629) Rafter Short RT 805.5mm (31-3/4")

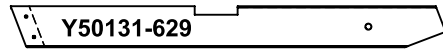

4pc. (630) Rafter Short LT 805.5mm (31-3/4")



4pc. (631) Rafter Centre LT 1338.9mm (52-3/4")

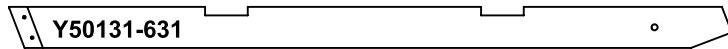

4pc. (632) Rafter Centre RT 1338.9mm (52-3/4")

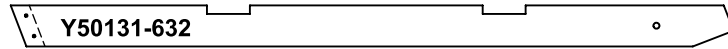

12pc. (633) Centre Rafter 1873.6mm (73-3/4")



2pc. (634) Rafter 1907mm (75-1/16")



2pc. (636) Top Strap 953.8mm (37-9/16")

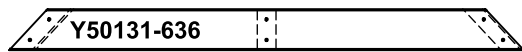

2pc. (637) Mid Strap 1908.3mm (75-1/8")

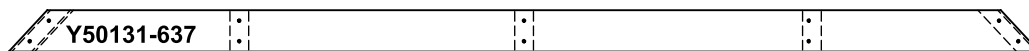

4pc. (645) Spacer 578.2mm (22-3/4")

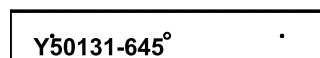

2pc. (1200) Spacer Long 637.4mm (25-1/16")

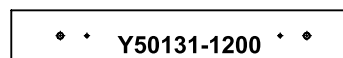

8pc. (646) Tie 2590.8mm (102")

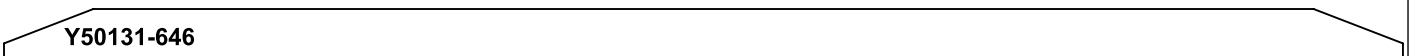

4pc. (648) Soffit 1774.5mm (69-7/8")

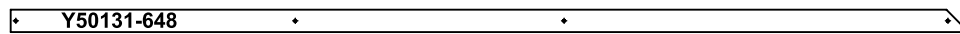

12 pc. (675) Middle Rafter 1907mm (75-1/16")

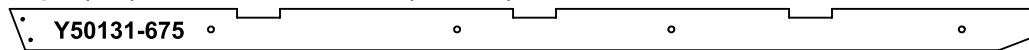

2pc. (676) Left End Fascia 1833.3mm (72-3/16")

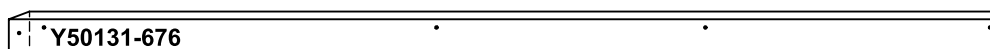

2pc. (677) Right End Fascia 1833.3mm (72-3/16")

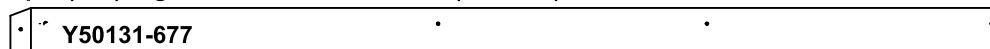

# Part Identification (Dimensions are approximate and are shown to assist in the identification of parts for assembly. Actual dimensions may be smaller or larger.)

2pc. (681) Left Top Strap 495.1mm (19-1/2")

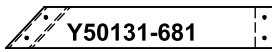

2pc. (682) Right Top Strap 495.1mm (19-1/2")

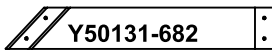

2pc. (683) Left Mid Strap 972.3mm (38-1/4")

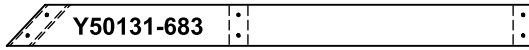

2pc. (684) Right Mid Strap 972.3mm (38-1/4")

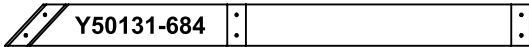

2pc. (685) Left Bot Strap 1448.1mm (57")

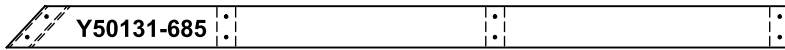

2pc. (686) Right Bot Strap 1448.1mm (57")

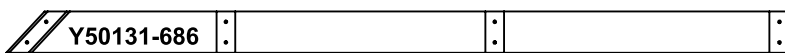

2pc. (687) Bottom Strap LT 2457mm (96-3/4")

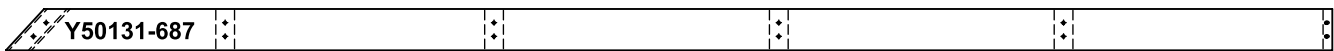

2pc. (688) Bottom Strap RT 406.3mm (16")

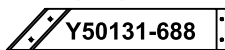

4pc. (690) Soffit End 1792mm (70-9/16")

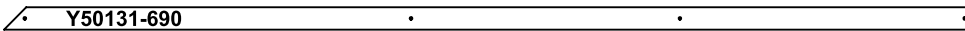

4pc. (1192) Mid Fascia 1857.4mm (73-1/8")

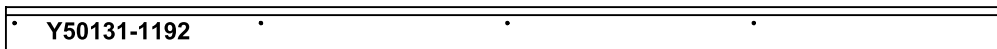

12pc. (1193) Centre Strap 1857.5mm (73-1/8")

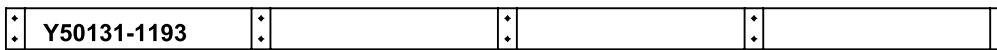

4pc. (1194) Rafter Top 1793.9mm (70-5/8")

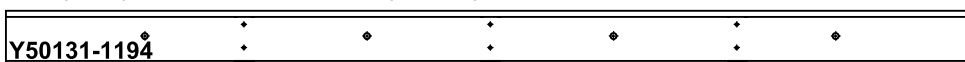

4pc. (1195) Soffit 1857.6mm (73-1/8")

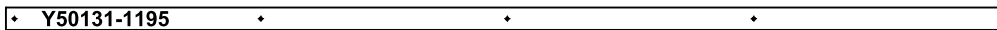

2pc. (1202) Centre Beam Long 2590.8mm (102")

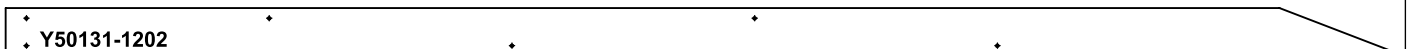

2pc. (1203) Centre Beam Short 309mm (12-3/16")

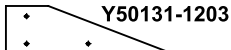

2pc. (1204) Centre Beam Bottom 1500mm (59")

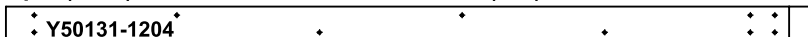

1pc. (1205) Centre Upright 444mm (17-1/2")

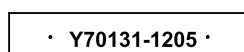

2pc. (1206) Centre Gusset 660.4mm (26")

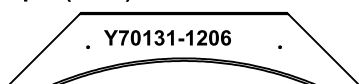

# Hardware Identification ( Dimensions are approximate and are shown to assist in the identification of parts for assembly. Actual dimensions may be smaller or larger. )

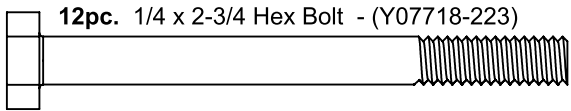

**12pc.** 1/4 x 2-3/4 Hex Bolt - (Y07718-223)

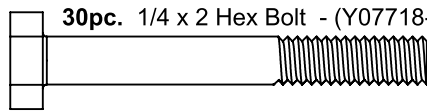

**30pc.** 1/4 x 2 Hex Bolt - (Y07718-220)

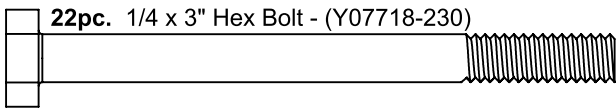

**22pc.** 1/4 x 3" Hex Bolt - (Y07718-230)

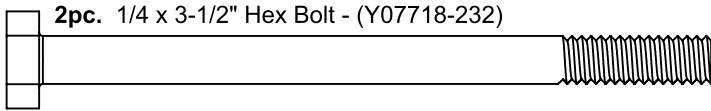

**2pc.** 1/4 x 3-1/2" Hex Bolt - (Y07718-232)

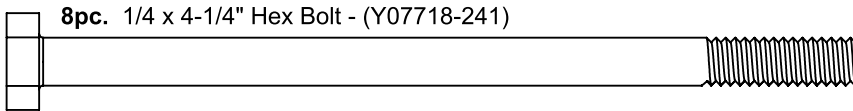

**8pc.** 1/4 x 4-1/4" Hex Bolt - (Y07718-241)

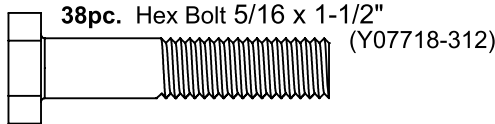

**38pc.** Hex Bolt 5/16 x 1-1/2" (Y07718-312)

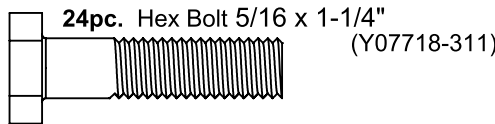

**24pc.** Hex Bolt 5/16 x 1-1/4" (Y07718-311)

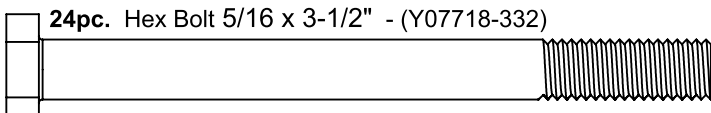

**24pc.** Hex Bolt 5/16 x 3-1/2" - (Y07718-332)

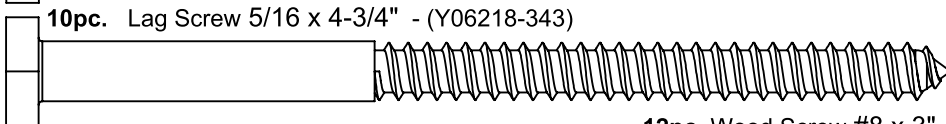

**10pc.** Lag Screw 5/16 x 4-3/4" - (Y06218-343)

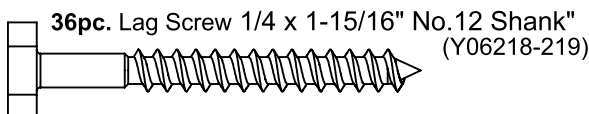

**36pc.** Lag Screw 1/4 x 1-15/16" No.12 Shank" (Y06218-219)

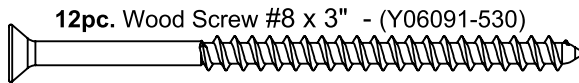

**12pc.** Wood Screw #8 x 3" - (Y06091-530)

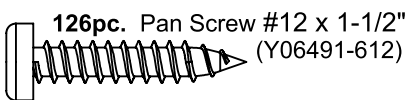

**126pc.** Pan Screw #12 x 1-1/2" (Y06491-612)

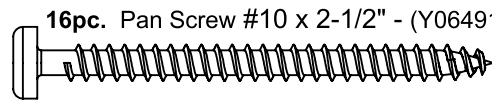

**16pc.** Pan Screw #10 x 2-1/2" - (Y06491-722)

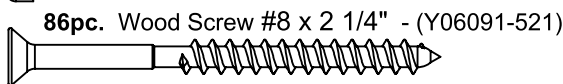

**86pc.** Wood Screw #8 x 2 1/4" - (Y06091-521)

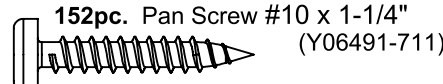

**152pc.** Pan Screw #10 x 1-1/4" (Y06491-711)

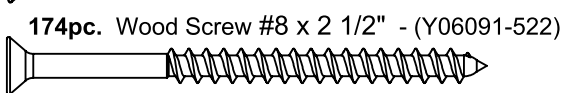

**174pc.** Wood Screw #8 x 2 1/2" - (Y06091-522)



**54pc.** Pan Screw #8 x 1" (Y06491-510)

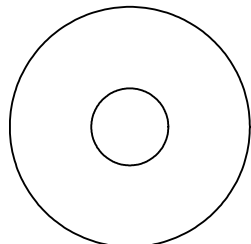

**20pc.** 3/8 x 1-1/4" Large Washer (Y05118-811)



**86pc.** - 1/4" Lock Nut (Y08318-203)

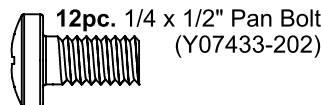

**12pc.** 1/4 x 1/2" Pan Bolt (Y07433-202)

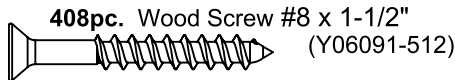

**408pc.** Wood Screw #8 x 1-1/2" (Y06091-512)

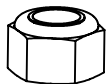

**10pc.** - 3/8" Lock Nut (Y08318-803)

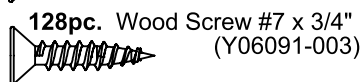

**128pc.** Wood Screw #7 x 3/4" (Y06091-003)

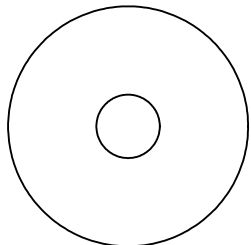

**268 pc.** 1/4-5/16 x 1-1/4" Large Washer (Y05118-311)

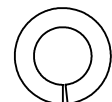

**86pc.** 5/16" Lock Washer (Y05318-300)

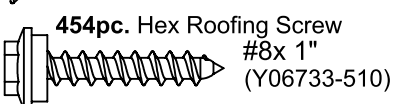

**454pc.** Hex Roofing Screw #8 x 1" (Y06733-510)

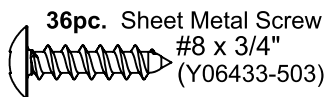

**36pc.** Sheet Metal Screw #8 x 3/4" (Y06433-503)

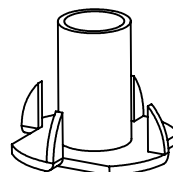

**86pc.** 5/16 - T-Nut (Y08518-300)

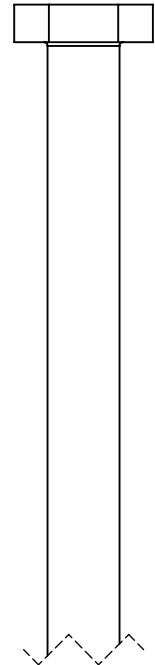

**10pc.** Hex Bolt 3/8 x 9-1/4" (Y07718-891)

# Hardware Identification

( Dimensions are approximate and are shown to assist in the identification of parts for assembly. Actual dimensions may be smaller or larger.)

4pc. - Short Panel Left (Y01033-200)

4pc. - Long Panel Left (Y01033-198)

12pc. - Middle Panel (Y01033-196)

1pc. - Roof Panel Set (Y70833-466)

4pc. - Long Panel Right (Y01033-197)

4pc. - Short Panel Right (Y01033-199)

4pc. Roof Edge Left 72.2 - (Y01033-134)

4pc. Roof Edge Right 72.2 - (Y01033-135)

8pc. Ridge Clip 102.5 - (Y01033-133)

12pc. Ridge Clip 73.5 - (Y01033-209)

4pc. Roof Edge Middle - (Y01033-467)

6pc. Ridge Cap Middle - (Y01033-207)

4pc. Short Beam Insert - (Y00429-473)

2pc. Centre Peak Cap - (Y01033-471)

1pc. Peak Cap Link (Y01033-472)

1pc. - Gazebo ID Plaque (Y70800-104)

2pc. - 50mm Hook (Y00418-050)

1pc. - Weather Seal Ridge Clip (8Pk) (Y70818-074)

1pc. - Weather Seal Ridge Clip 75-1/2 (12Pk) (Y70818-468)

2pc. Peak Cap Detail (Y01033-347)

4pc. Ridge Cap Short 25.2 (Y01033-132)

4pc. Ridge Cap Long 81.5 (Y01033-131)

# Hardware Identification ( Dimensions are approximate and are shown to assist in the identification of parts for assembly. Actual dimensions may be smaller or larger. )

**4pc. Roof Peak Bracket (Y00429-125)**

**1pc. - Roof Peak Set (12 x 24) (Y70829-465)**

**6pc. 1/4" Nut (Y08490-200)**

**6pc. Contour Washer (Y05918-211)**

**6pc. Carriage Bolt (Y07490-260)**

**6pc. Spring Clip (Y09490-001)**

**6pc. Peak Loop (Y20018-003)**

**6pc. Peak Post (Y01000-094)**

**4pc. Peak Bracket (Y00429-190)**

**1pc. - Large Centre Roof Bracket Set (2Pk) (Y70829-464)**

**1pc. - Large Corner Bracket Set (2Pk) (Y70829-469)**

**1pc. - Large Flat Bracket Set (6Pk) (Y70829-470)**

**3pc. - Roof To Beam Bracket Set (10Pk) (Y70819-218)**

**1pc. - 45° Twist Bracket LT (2 Pack) (Y70829-191)**

**1pc. - 45° Twist Bracket RT (2 Pack) (Y70829-192)**

**6pc. - Roof Edge Centre (Y01030-217)**

**1pc. - Post Mount Set (12Pk) (Y70819-219)**

**1pc. - Beam to Rafter Bracket (4Pk) (Y70829-212)**

**1pc. Double Tie Wrap Bracket RT(2Pk) (Y70829-213)**

**1pc. Double Tie Wrap Bracket LT(2Pk) (Y70829-214)**

**2pc. Tie Wrap Bracket (2Pk) (Y70829-163)**

**1pc. Tie Wrap Bracket (8Pk) (Y70819-106)**

**1pc. - 1/8" Drill Bit (Y00400-002)**

**1pc. Steel Cable with Bracket (Y70829-204)**

**1pc. - Corner Cap Set (4Pk) (Y70833-103)**

**1pc. #2 x 2" Robertson Driver (Y00400-005)**

**1pc. - Hex Driver (Y00400-004)**

# Step 1: Inventory Parts - Read This Before Starting Assembly

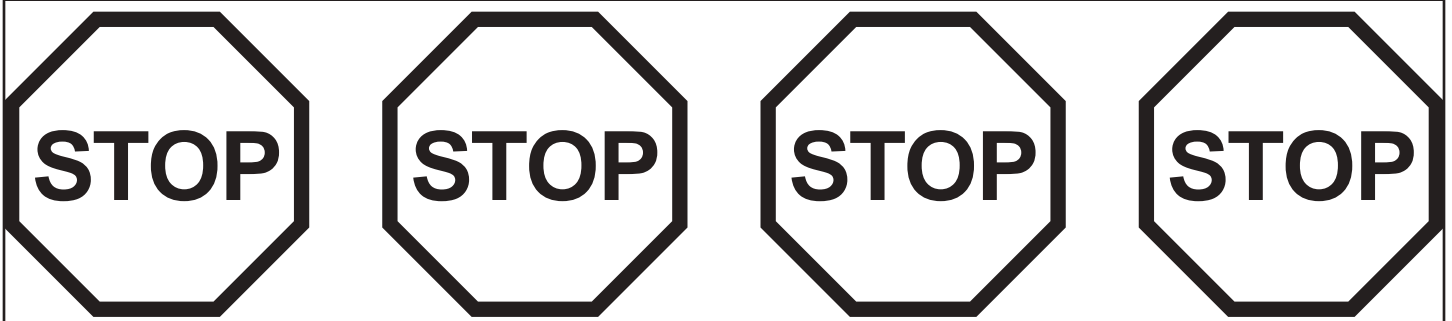

- A.** This is the time for you to inventory all your hardware, wood and accessories, referencing the parts identification sheets. This will assist you with your assembly.
- Each step indicates which bolts and/or screws you will need for assembly, as well as any flat washers, lock washers, t-nuts or lock nuts.
- B.** If there are any missing or damaged pieces or you need assistance with assembly please contact the consumer relations department directly. Call us before going back to the store.

**1-888-509-4382**  
**support@yardistrystructures.com**

- C.** Read the assembly manual completely, paying special attention to ANSI warnings; notes; and safety/maintenance information on pages 1 - 4.
- Follow the instructions in order.
  - This structure is designed to be assembled and installed ideally by four people, DO NOT attempt to install alone.
  - Consider the slope of elevation where you plan to install the structure. Also, check for gas, telephone, other utilities or sprinkler line locations prior to excavating any holes.
- D.** Before you discard your cartons fill out the form below.
- The carton I.D. stamp is located on the end of each carton.
  - Please retain this information for future reference. You will need this information if you contact the Consumer Relations Department.

**PRODUCT NUMBER: YM11937**

CARTON I.D. STAMP: __ _ _ _ _ (Box 1)
CARTON I.D. STAMP: __ _ _ _ _ (Box 2)
CARTON I.D. STAMP: __ _ _ _ _ (Box 3)
CARTON I.D. STAMP: __ _ _ _ _ (Box 4)
CARTON I.D. STAMP: __ _ _ _ _ (Box 5)

## Step 2: Post Assemblies

**A:** At the bottom of one (696) 6 x 6 Post insert one 5/16" T-Nut on the outside of two sides, as shown in F2.3.

**B:** At the bottom of the same (696) 6 x 6 Post place two Post Mounts tight to the bottom and inside faces on the sides as shown in F2.1 and F2.2. Loosely attach with one 5/16 x 1-1/4" Hex Bolt (with 5/16" lock washer and 1/4-5/16" large washer) per mount so they connect to the T-Nuts. From the bottom attach with two #8 x 1-1/2" Wood Screws and two #10 x 1-1/4" Pan Screws per mount. Tighten bolts.

**C:** Flush to the bottom of (696) 6 x 6 Post place one (422) Plinth on each side, attach with four #8 x 1-1/2" Wood Screws per plinth. Rounded edges on top. (F2.1, F2.2 and F2.3)

**D:** Repeat Steps A - C five more times to make six Post Assemblies.

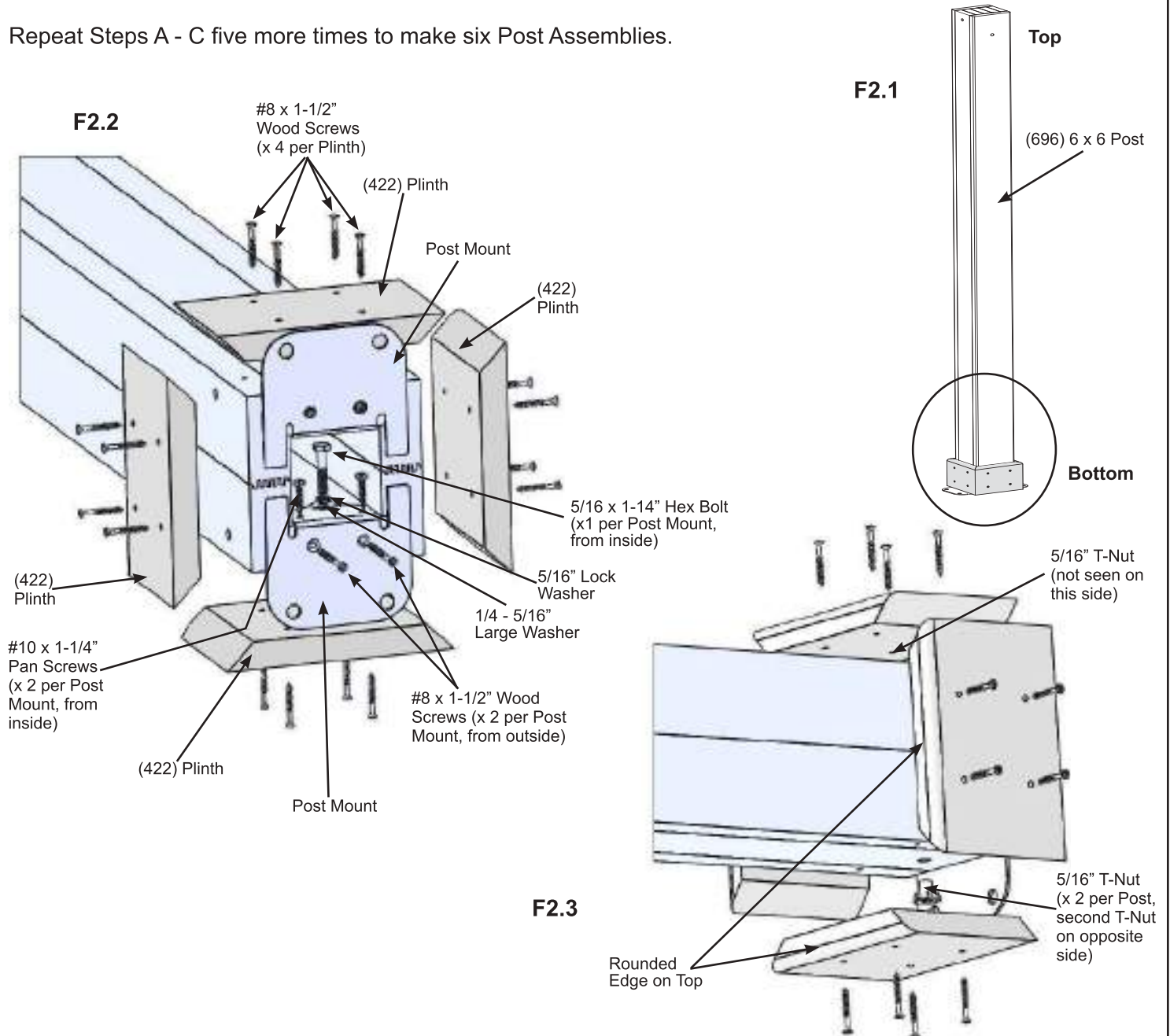

### Wood Parts

6 x (696) 6 x 6 Post  
24 x (422) Plinth

### Hardware

120 x #8 x 1-1/2" Wood Screw  
24 x #10 x 1-1/4" Pan Screw  
12 x Post Mount

12 x 5/16" T-Nut  
12 x 5/16 x 1-1/4" Hex Bolt  
(with 5/16" lock washer, 1/4 - 5/16" large washer)

# Step 3: Short Beam Assembly Part 1

**A:** Connect one (1002) Beam Short Left and one (1003) Beam Short Right using two 5/16 x 1-1/2" Hex Bolts (with 5/16" lock washer, 1/4-5/16" large washer and 5/16" t-nut) as shown in F3.1 and F3.2.

**B:** Connect one (1004) Beam Short End to each end of one (1005) Beam Short Centre using two 5/16 x 1-1/2" Hex Bolts (with 5/16" lock washer, 1/4-5/16" large washer and 5/16" t-nut) per end as shown in F3.1 and F3.2.

**C:** Repeat Steps A and B one more time to make two Short Beam L-R Assemblies and two Short Beam End Assemblies.

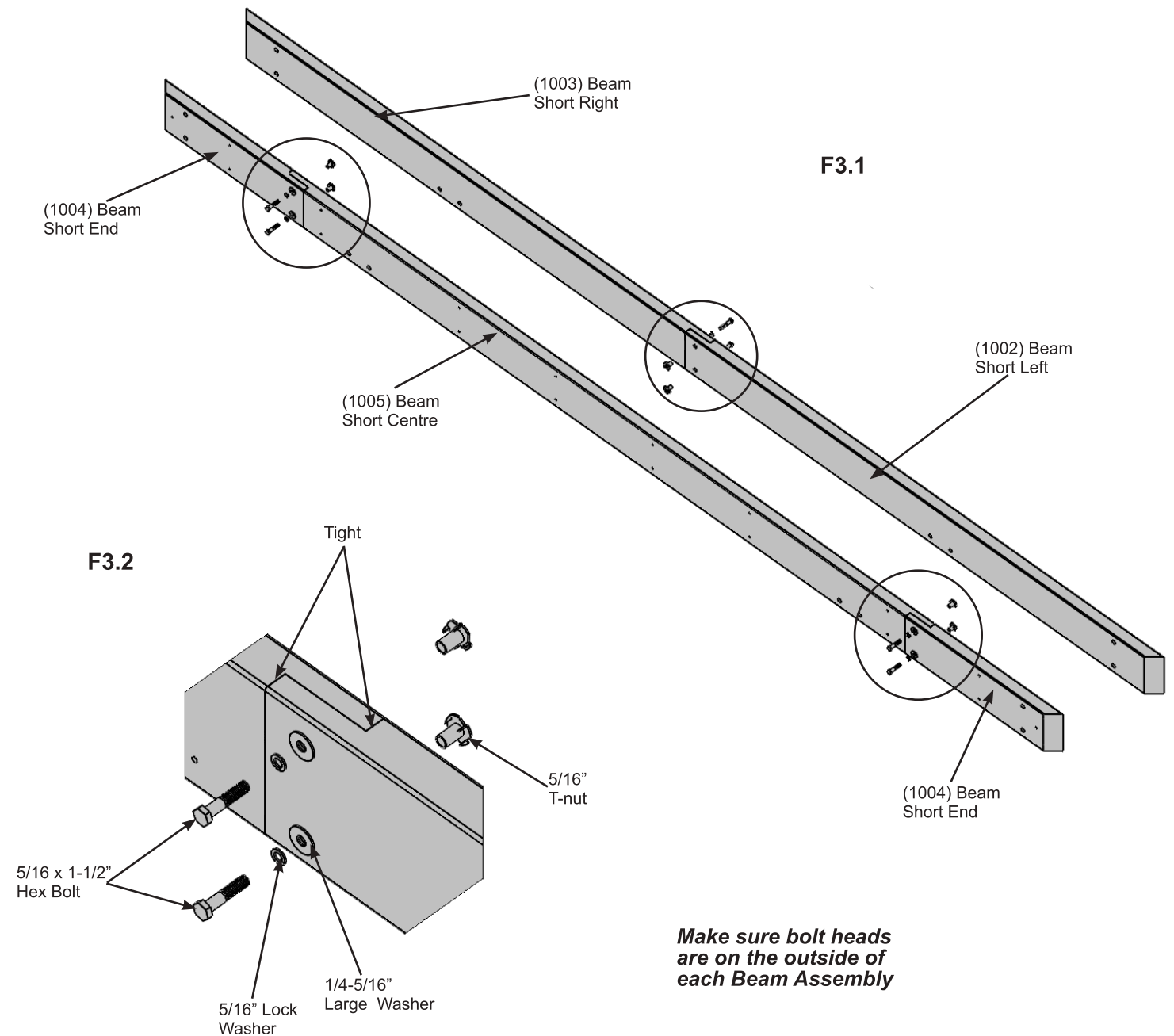

## Wood Parts

- 4 x (1004) Beam Short End
- 2 x (1005) Beam Short Centre
- 2 x (1002) Beam Short Left
- 2 x (1003) Beam Short Right

## Hardware

- 12 x 5/16 x 1-1/2" Hex Bolt  
(5/16" lock washer, 1/4-5/16" large washer, 5/16" t-nut)



## Step 3: Short Beam Assembly Part 2

**D:** Place one Short Beam L-R Assembly tight to one Short Beam End Assembly so the ends are flush. Match the bolt holes in each (1004) Beam Short End with the bolt holes in (1002) Beam Short Left and (1003) Beam Short Right. Attach with 18 #8 x 2-1/2" Wood Screws. (F3.3 and F3.4)

**E:** Repeat Step D one more time to make two Short Beam Assemblies.

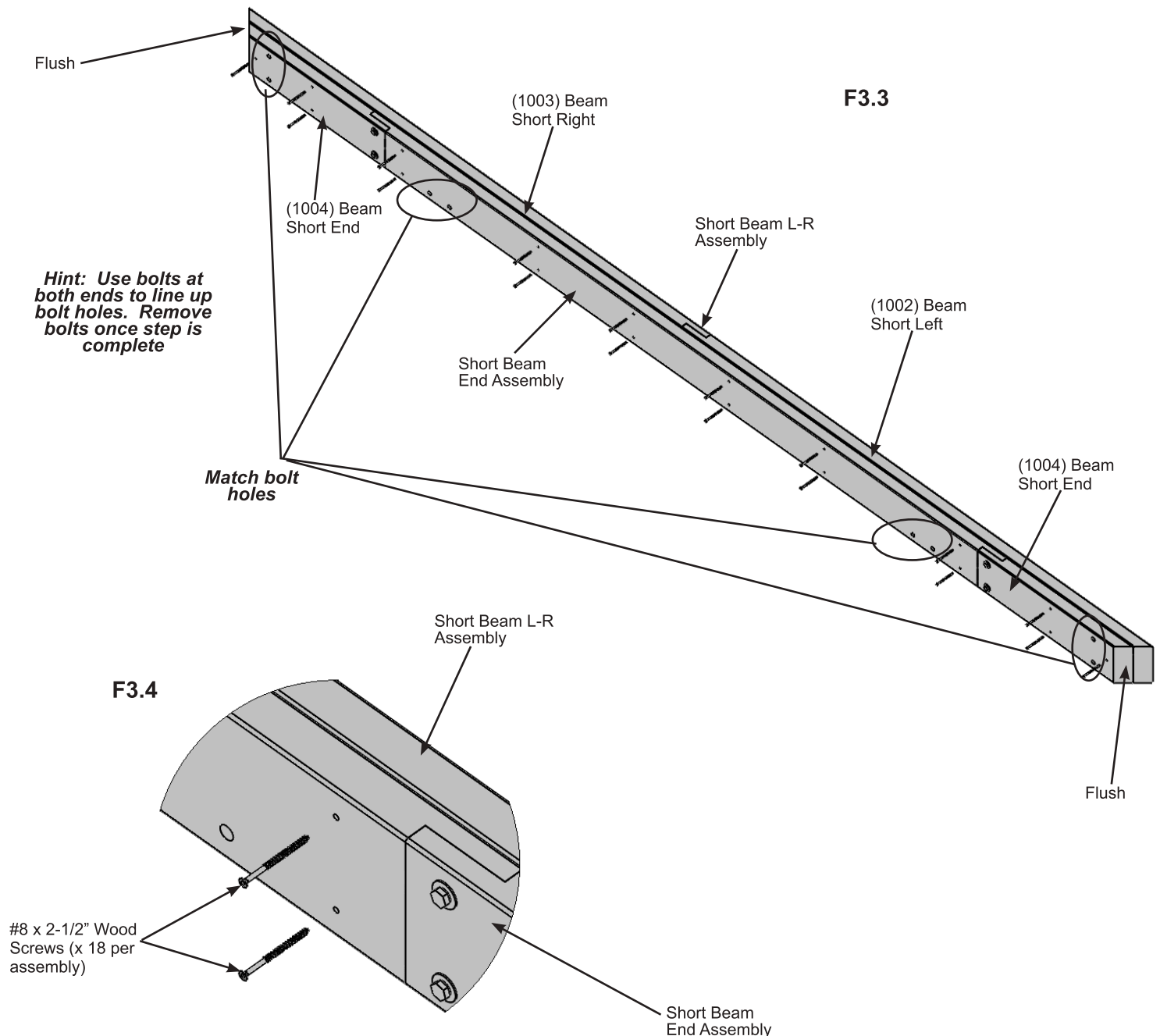

### Hardware

36 x #8 x 2-1/2" Wood Screw

# Step 4: Long Beam Assembly Part 1

**A:** Connect one (1199) Outer End to each end of one (1196) Beam using four 5/16 x 1-1/2" Hex Bolts (with 5/16" lock washer, 1/4-5/16" large washer and 5/16" t-nut) as shown in F4.1 and F4.2. Notice orientation of angled ends. This will create an Outer Beam Assembly.

**B:** On the short side of the Outer Beam Assembly place two Short Beam Inserts so they fit over the holes in (1196) Beam and (1199) Outer Ends. Attach Short Beam Inserts to Outer Beam Assembly with ten #7 x 3/4" Wood Screws per insert, as shown in F4.3 and F4.4.

**C:** Repeat Steps A and B to make two Outer Beam Assemblies.

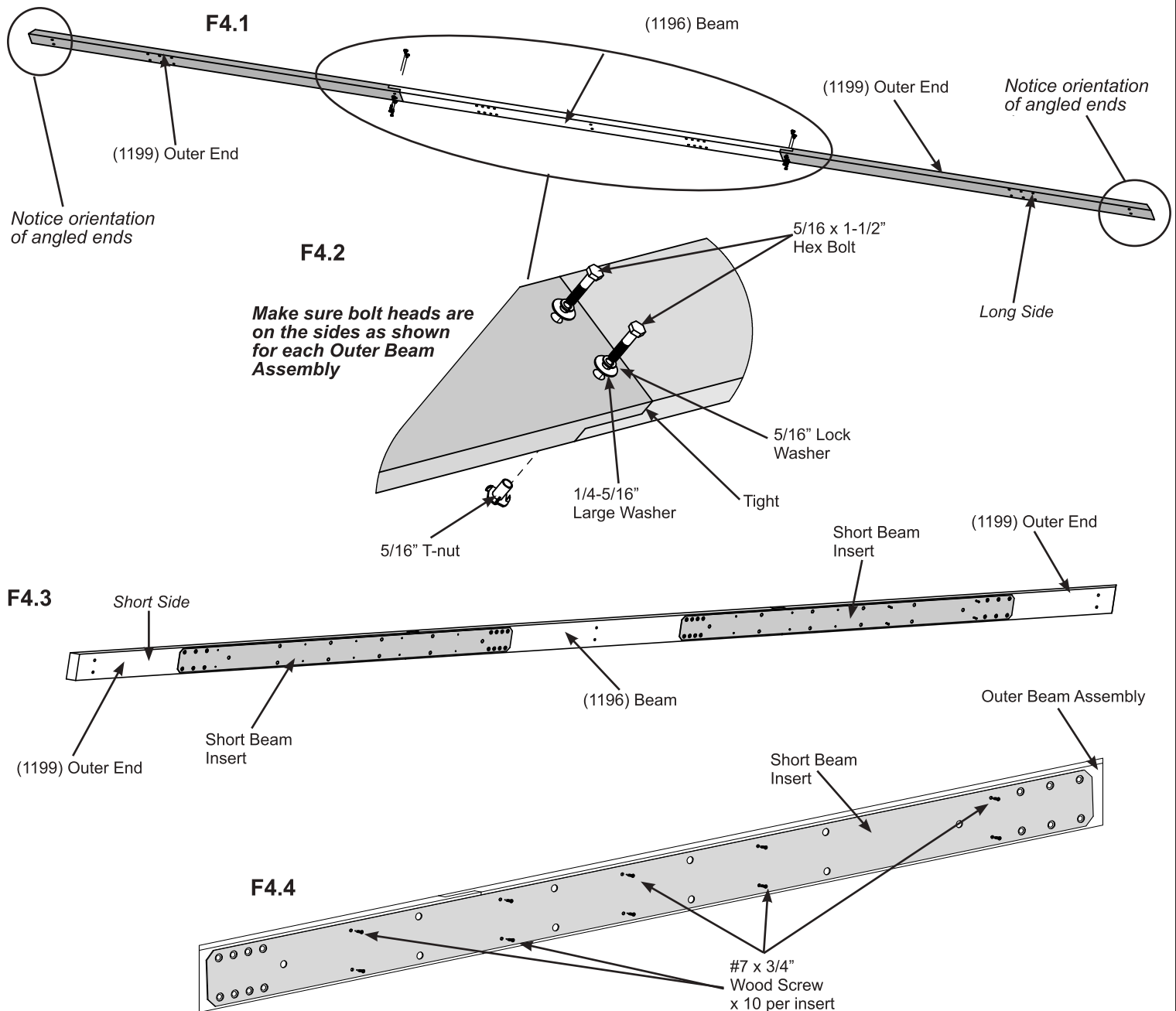

### Wood Parts

2 x (1196) Beam  
4 x (1199) Outer End

### Component

4 x Short Beam Insert

### Hardware

8 x 5/16 x 1-1/2" Hex Bolt  
(5/16" lock washer, 1/4-5/16" large washer, 5/16" t-nut)  
40 x #7 x 3/4" Wood Screw

# Step 4: Long Beam Assembly Part 2

**D:** Connect one (1201) Inside Middle Beam to each end of one (1198) Inside Beam using four 5/16 x 1-1/2" Hex Bolts (with 5/16" lock washer, 1/4-5/16" large washer and 5/16" t-nut). At the end of each (1201) Inside Middle Beam connect one (1197) Beam End with two 5/16 x 1-1/2" Hex Bolts (with 5/16" lock washer, 1/4-5/16" large washer and 5/16" t-nut) per end. Notice the orientation of angled ends. This is the Inside Beam Assembly. (F4.5 and F4.6)

**E:** Repeat Steps D to make two Inside Beam Assemblies.

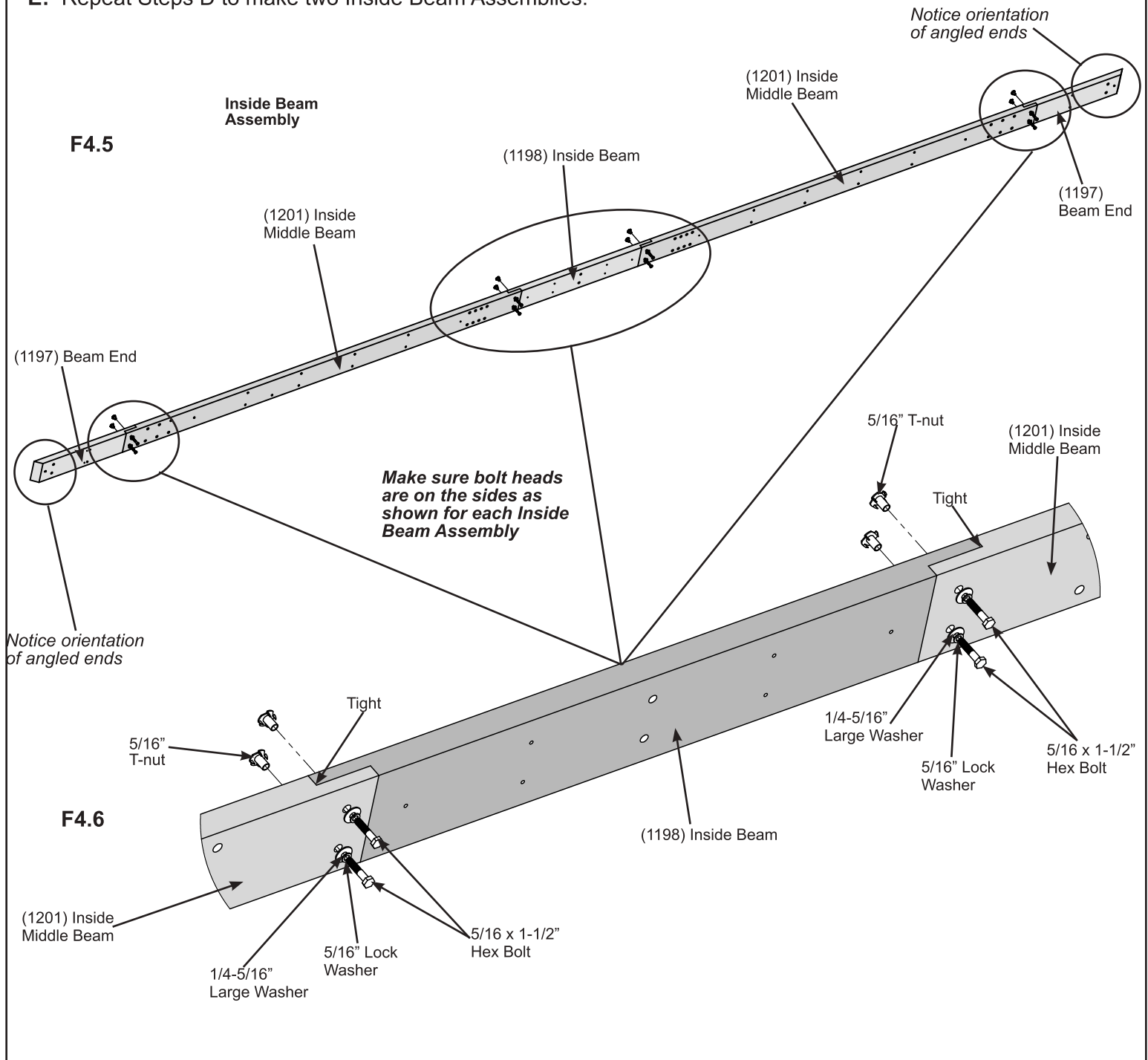

### Wood Parts

- 2 x (1198) Inside Beam
- 4 x (1201) Inside Middle Beam
- 4 x (1197) Beam End

### Hardware

- 16 x 5/16 x 1-1/2" Hex Bolt  
(5/16" lock washer, 1/4-5/16" large washer, 5/16" t-nut)

# Step 4: Long Beam Assembly Part 3

**F:** Place one Inside Beam Assembly tight to one Outer Beam Assembly so the ends are flush and the angled ends match. Bolt heads from the Outer Beam Assembly must be on the outside and Short Beam Inserts will be on the inside. Connect Inside Beam Assembly to Outer Beam Assembly with 32 #8 x 2-1/2" Wood Screws. (F4.7 and F4.8)

**G:** Repeat Step F with to make 2 Long Beam Assemblies.

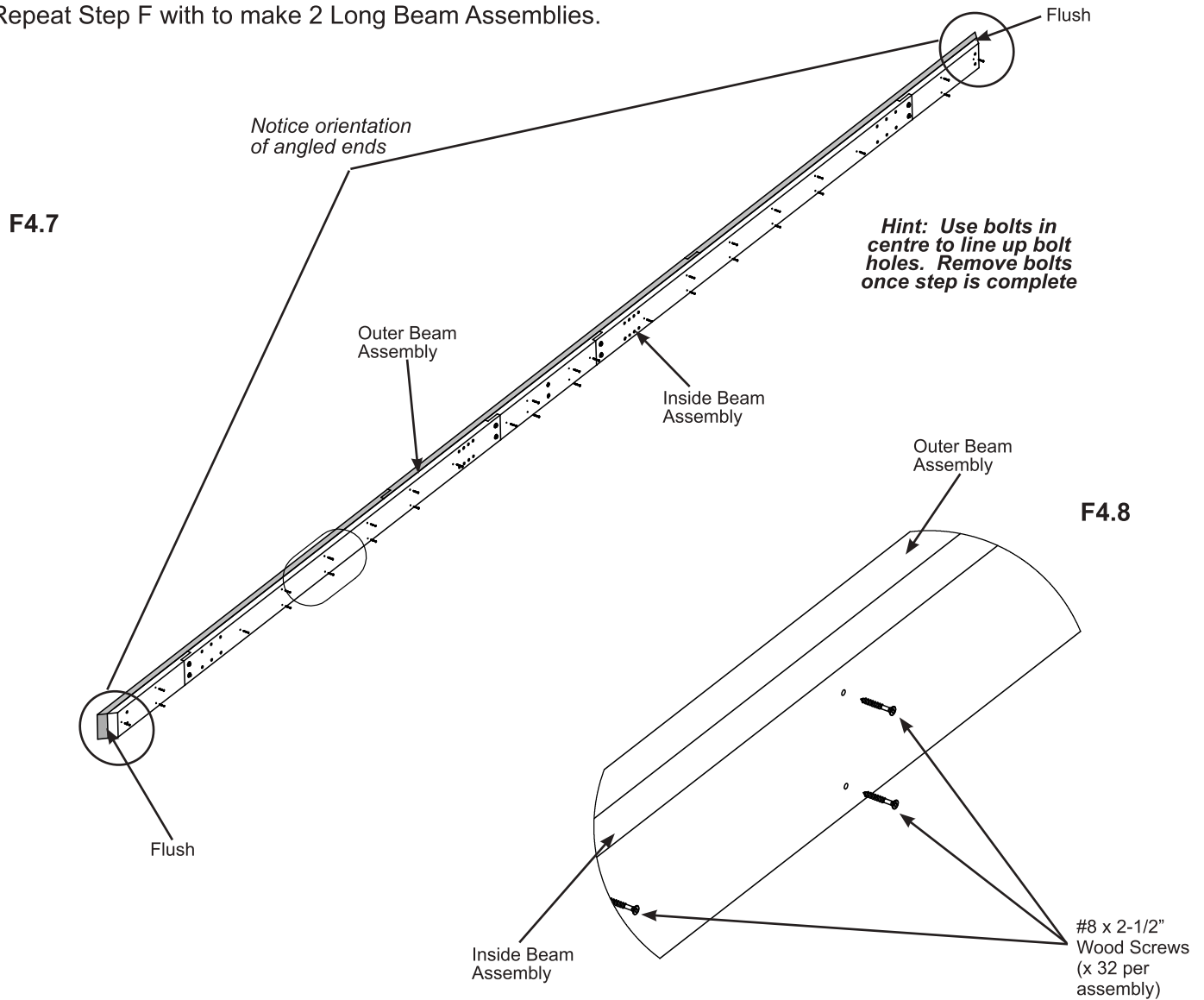

## Hardware

64 x #8 x 2-1/2" Wood Screw

# Step 5: Frame Assembly and Anchoring Part 1



**A:** On a hard, flat surface place one Short Beam Assembly against the outside of two Post Assemblies, flush to the tops and outside corners. Attach Beam to Post, through the bottom hole, with one 3/8 x 9-1/4" Hex Bolt (with two 3/8" large washers and one 3/8" lock nut) per Post Assembly. (F5.1 and F5.2)

*The distance from the outside of one Post Assembly to the outside of the second Post Assembly should be 10' 10-3/8" (3.312 m). See F5.3 for accurate positioning of Posts.*

**B:** Repeat for second Short Beam Assembly. These will now be referred to as Short Side Assemblies. (F5.1 and F5.2)

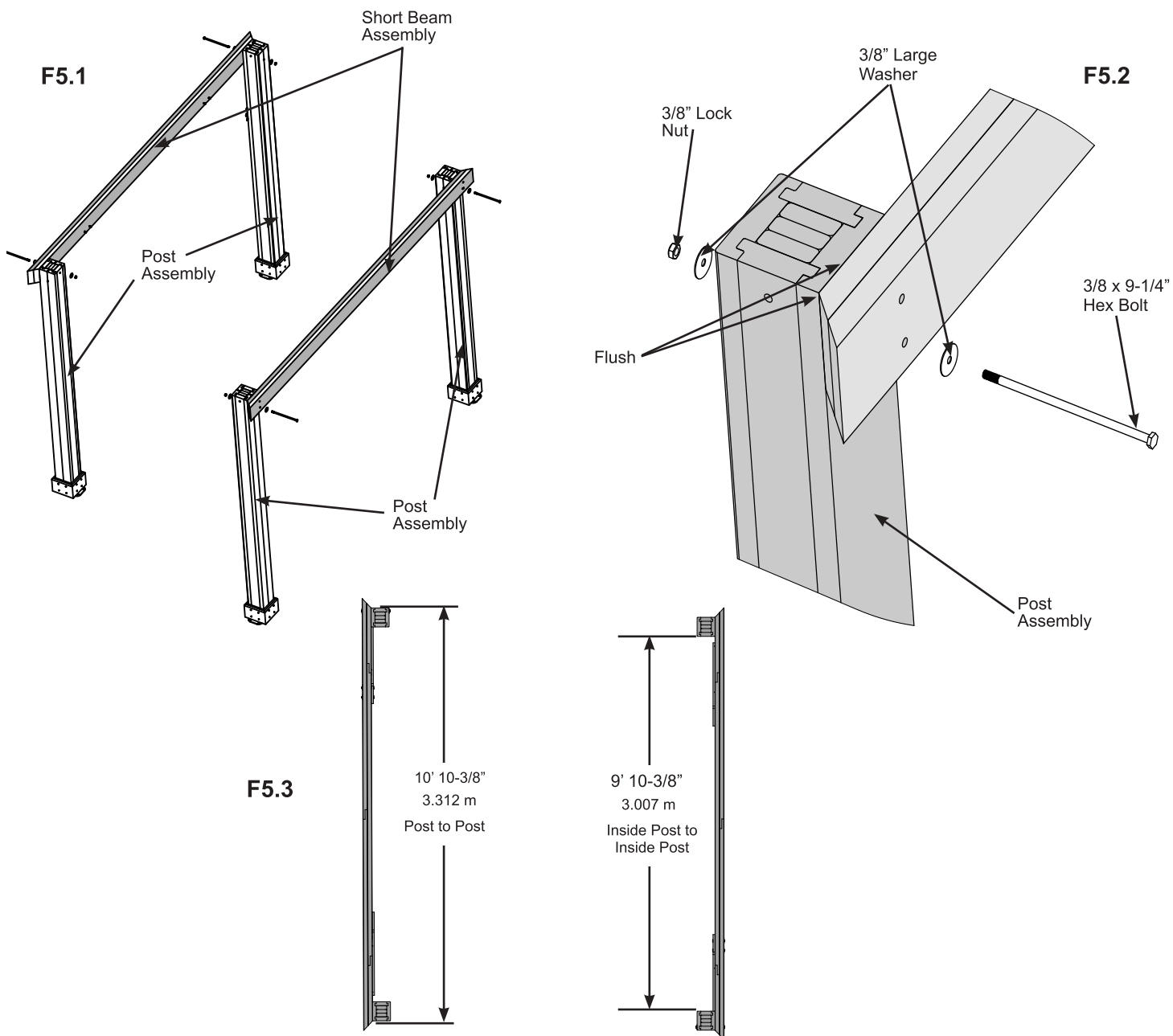

### Hardware

4 x 3/8 x 9-1/4" Hex Bolt (3/8" large washer x 2, 3/8" lock nut)

# Step 5: Frame Assembly and Anchoring Part 2



**Note:** The bevelled ends on each gusset should always face away from the wood it is attaching to.

**C:** Make sure each Short Side assembly is square with the Post Assembly then facing one Short Beam Assembly from the outside place one (705) Gusset RT on the right hand side so the top fits tight to the Beam Assembly and the bottom fits tight to the Post Assembly. Attach gusset to Beam Assembly with two 5/16 x 3-1/2" Hex Bolts (with 5/16" lock washer, 1/4-5/16" large washer and 5/16" t-nut). Pre-drill with a 1/8" drill bit then attach gusset to Post Assembly with three 1/4 x 1-15/16" Lag Screws (with 1/4-5/16" large washer). (F5.4 and F5.5)

**D:** Repeat Step C on the left hand side with one (706) Gusset LT. (F5.4 and F5.5)

**E:** Repeat Steps C and D for second Short Side Assembly. (F5.4 and F5.5)

**F5.4**

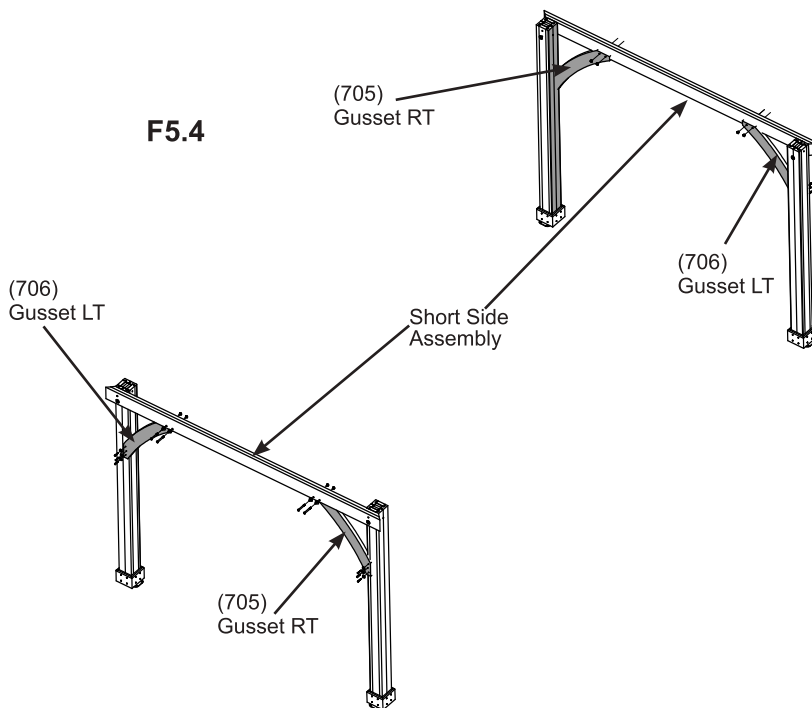

**F5.5**

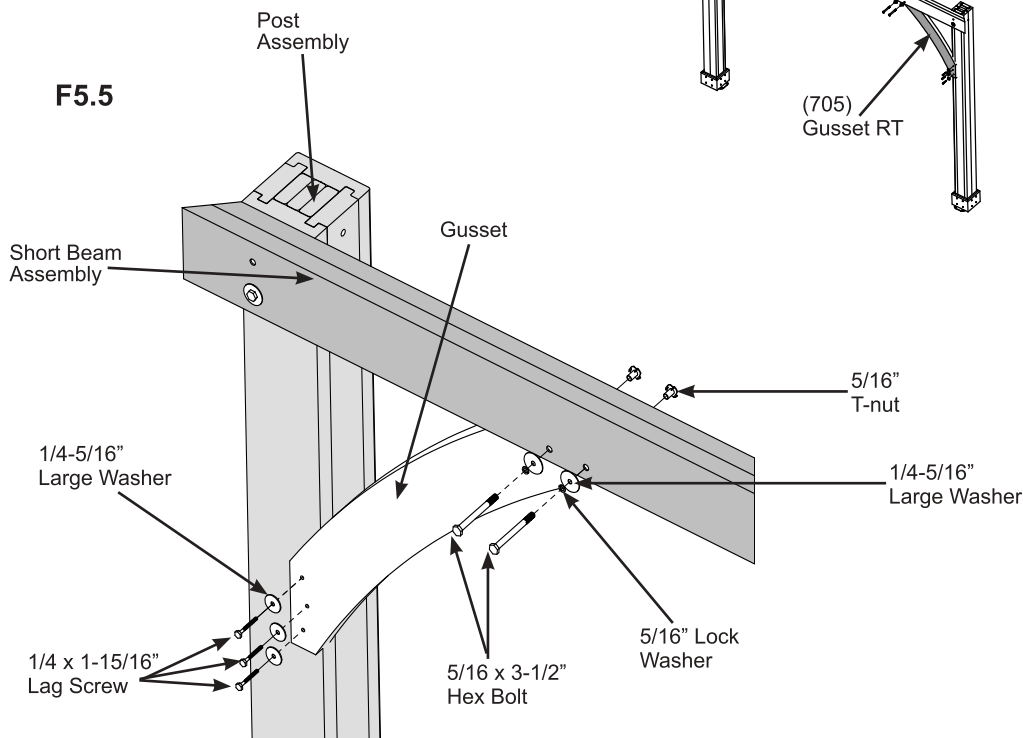

**Wood Parts**

- 2 x (705) Gusset RT
- 2 x (706) Gusset LT

**Hardware**

- 12 x 1/4 x 1-15/16" Lag Screw (1/4-5/16" large washer)
- 8 x 5/16 x 3-1/2" Hex Bolt (5/16" lock washer, 1/4-5/16" large washer, 5/16" t-nut)

# Step 5: Frame Assembly and Anchoring Part 3



**F:** Move your Post Assemblies to the final location. Make sure the ground is flat and level before continuing assembly.

**G:** With helpers stand up Short Side Assemblies then place one Long Beam Assembly against the outside of two Post Assemblies, flush to the tops and outside corners and tight to Short Beam Assembly. Attach Long Beam Assembly to Post Assemblies through the top hole with one 3/8 x 9-1/4" Hex Bolt (with two 3/8" large washers and one 3/8" lock nut) per Post. Repeat for the second Long Beam Assembly on the opposite side. (F5.6, F5.7 and F5.8)

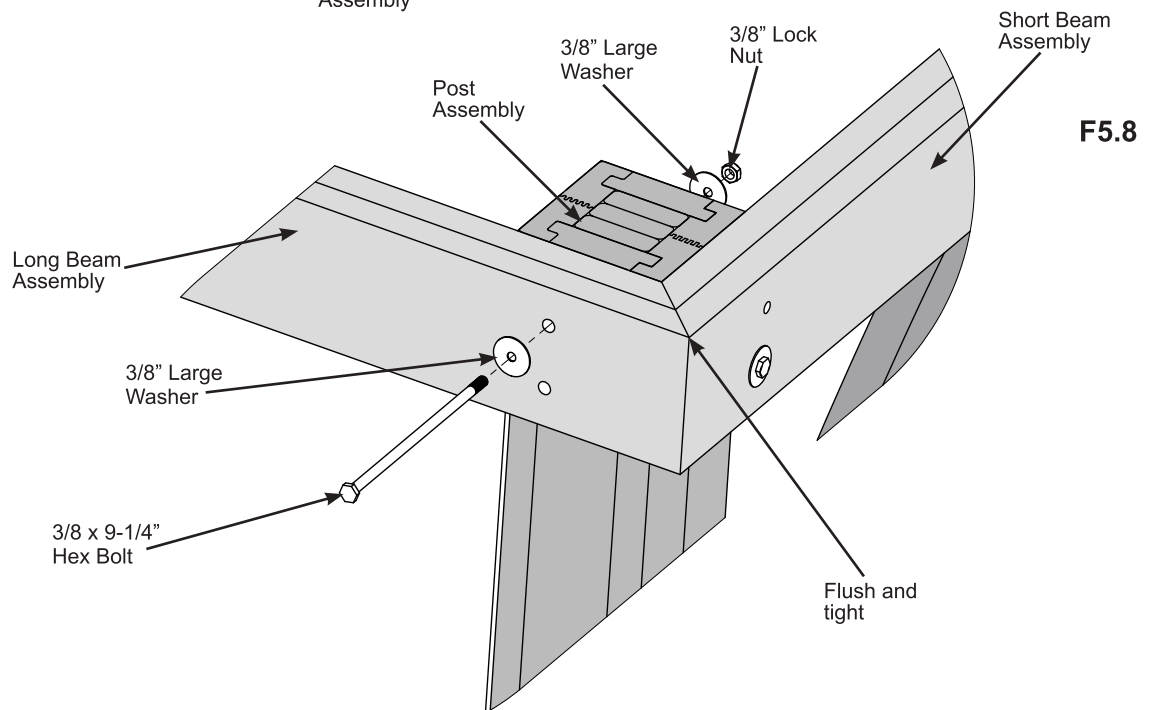
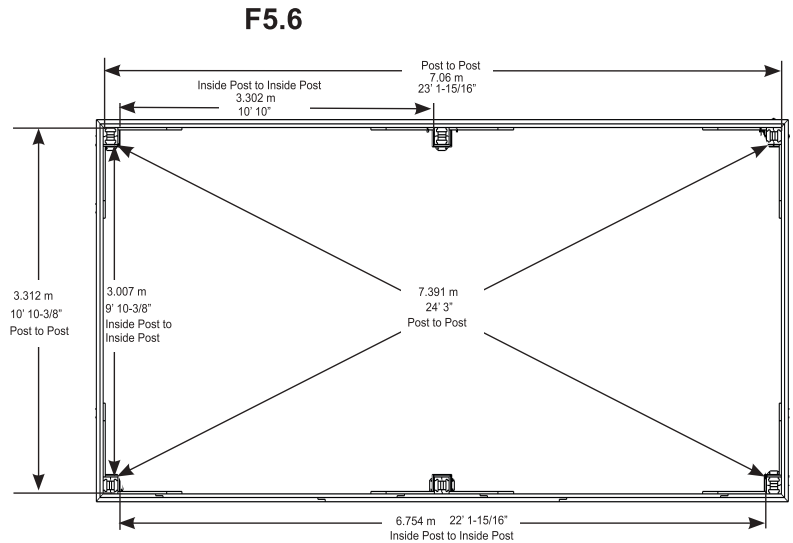
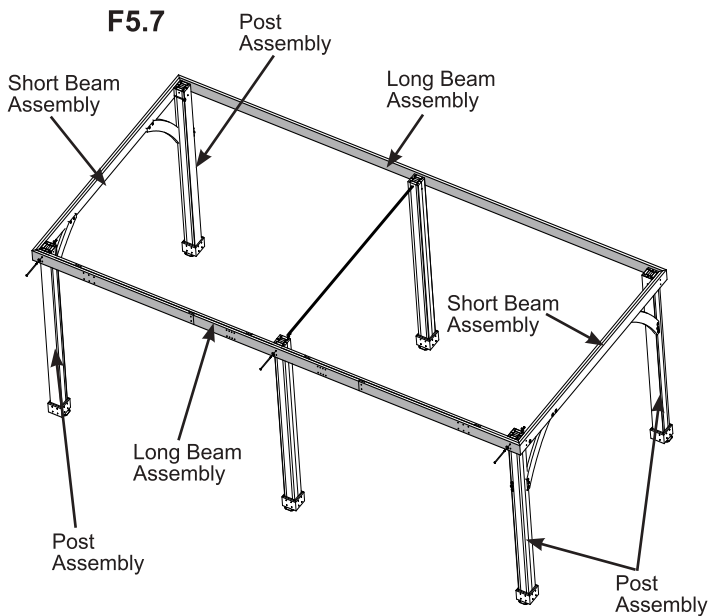

### Hardware

4 x 3/8 x 9-1/4" Hex Bolt (3/8" large washer x 2, 3/8" lock nut)

# Step 5: Frame Assembly and Anchoring Part 4



**H:** From inside the assembly, centre one Post Assembly over middle bolt holes in each Long Beam Assembly then place Steel Cable with Bracket against both Post Assemblies so the angle of the bracket faces up and is over the top bolt hole. Attach Long Beam Assembly to Post Assembly and Steel Cable with Bracket through the top hole with one 3/8 x 9-1/4" Hex Bolt (with two 3/8" large washers and one 3/8" lock nut). (F5.9 and F5.10)

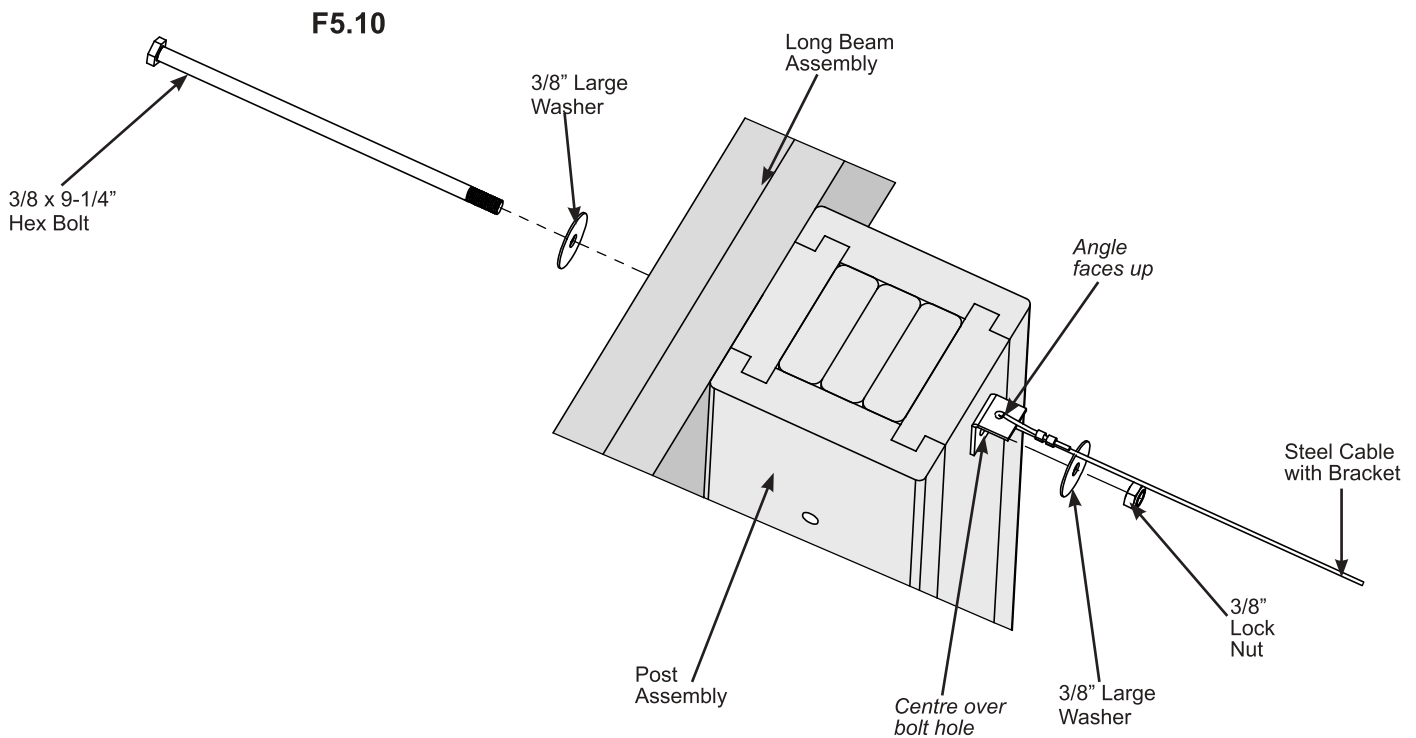
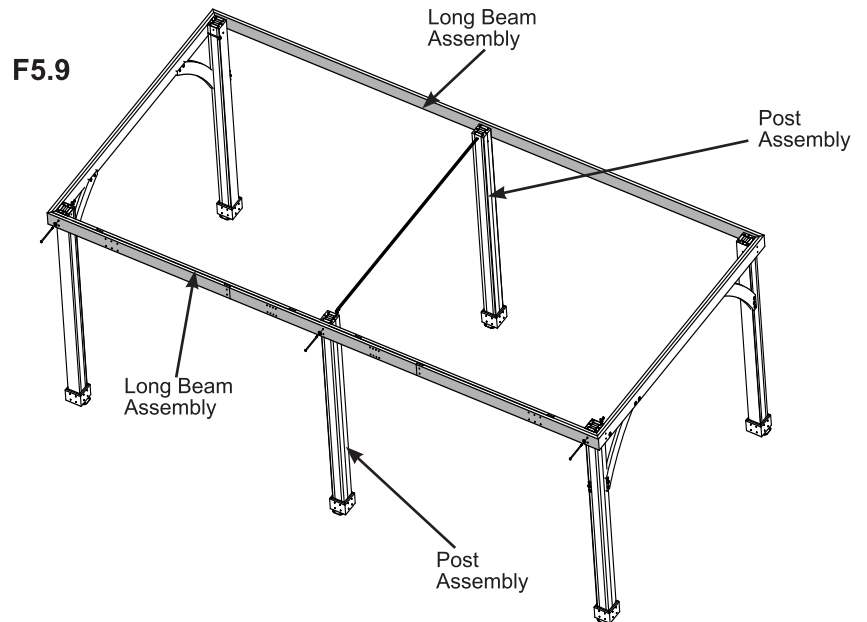

### Components

1 x Steel Cable with Bracket

### Hardware

2 x 3/8 x 9-1/4" Hex Bolt  
(3/8" large washer x 2, 3/8" lock nut)



# Step 5: Frame Assembly and Anchoring Part 5



**Note:** The bevelled ends on each gusset should always face away from the wood it is attaching to.

**I:** Make sure the Frame Assembly is square and level then facing one Long Beam Assembly from the outside place one (705) Gusset RT on the right hand side Post Assembly and one on the left side of the middle Post Assembly so the tops fit tight to the Beam Assembly and the bottom fits tight to the posts. Attach each gusset to Long Beam Assembly with two 5/16 x 3-1/2" Hex Bolts (with 5/16" lock washer, 1/4-5/16" large washer and 5/16" t-nut) per gusset. Pre-drill with a 1/8" drill bit then attach each gusset to each post with three 1/4 x 1-15/16" Lag Screws (with 1/4-5/16" large washer) per gusset. (F5.11 and F5.12)

**J:** Repeat Step I to install two (706) Gusset LT, one on the left hand side Post Assembly and the other on the right side of the middle Post Assembly. (F5.11 and F5.12)

**K:** Repeat Steps I and J for the second Long Side. (F5.11 and F5.12)

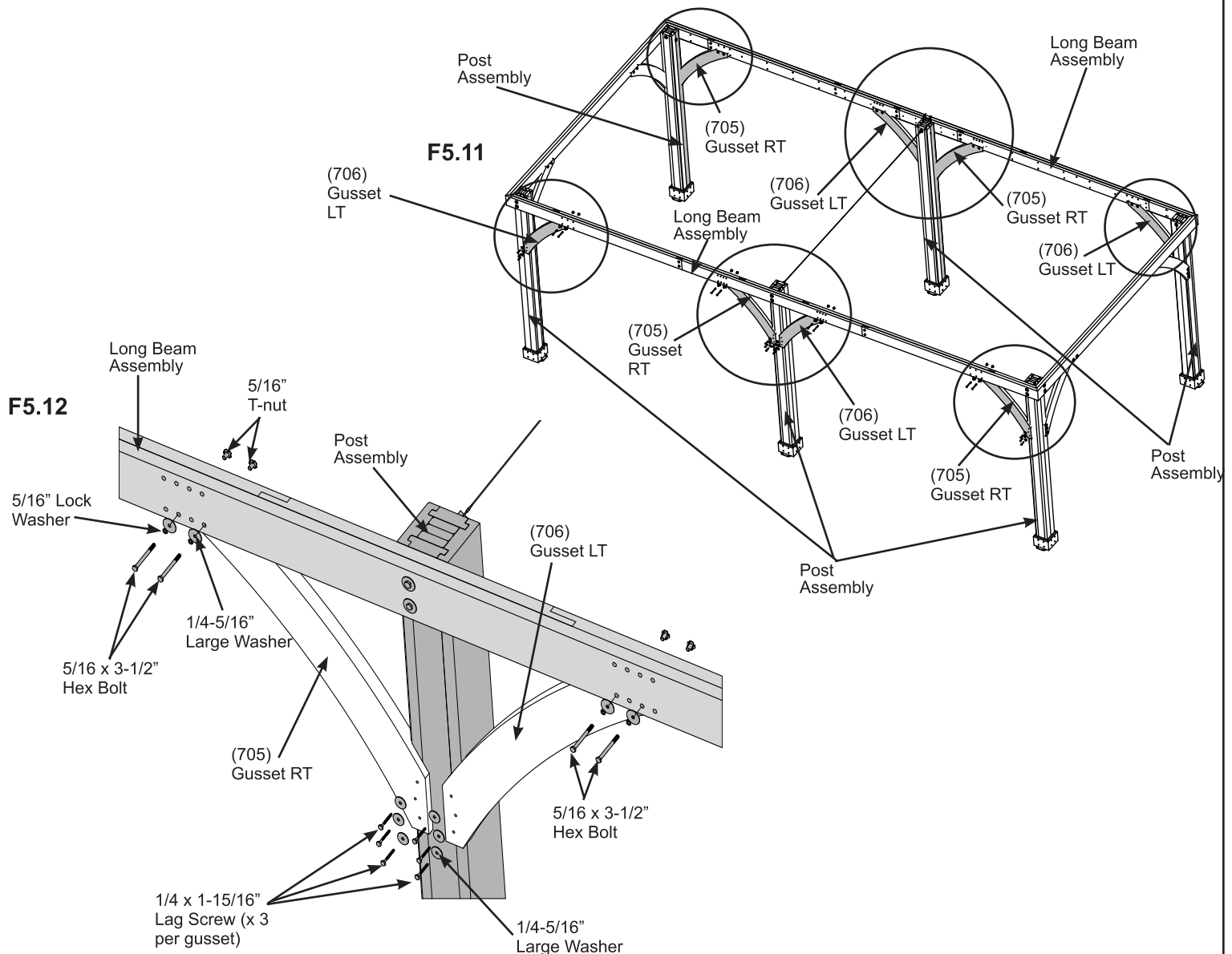

### Wood Parts

- 4 x (705) Gusset RT
- 4 x (706) Gusset LT

### Hardware

- 24 x 1/4 x 1-15/16" Lag Screw (1/4-5/16" large washer)
- 16 x 5/16 x 3-1/2" Hex Bolt (5/16" lock washer, 1/4-5/16" large washer, 5/16" t-nut)

# Step 5: Frame Assembly and Anchoring Part 6



**L:** Attach Long and Short Beam Assemblies to outside Post Assemblies with two 5/16 x 4-3/4" Lag Screws (with 1/4-5/16" large washer) per corner in the remaining holes. (F5.13)

**M:** Attach Long Beam Assembly to both middle Post Assemblies through the bottom holes with one 5/16 x 4-3/4" Lag Screw (with 1/4-5/16" large washer) per post. (F5.14)

**N:** Depending on what you are placing the Gazebo on will determine how you anchor it to that surface. Please refer to pages 6 and 7 for installation examples.

**Any hardware or extra materials for mounting will have to be purchased in advance.**

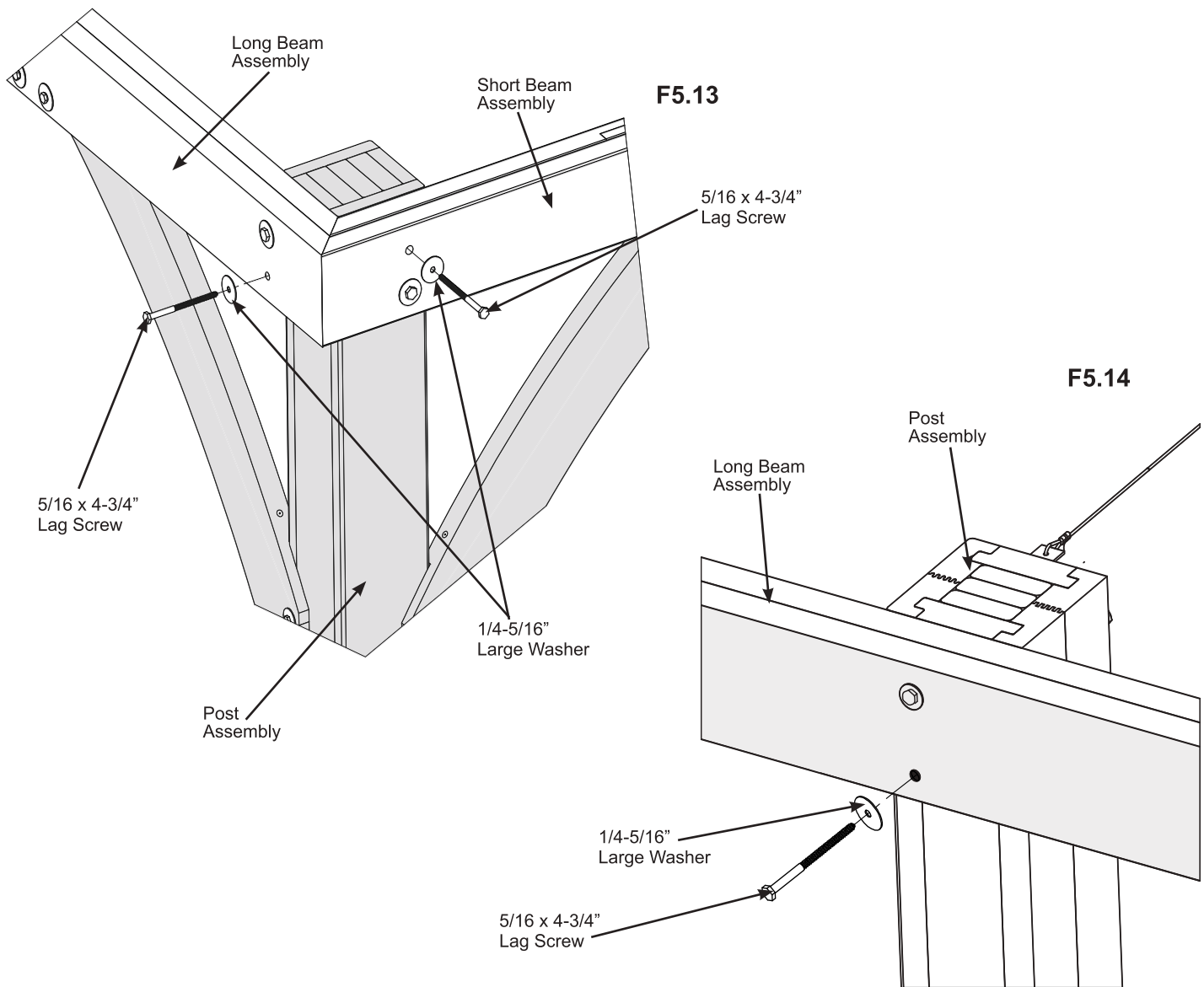

### Hardware

10 x 5/16 x 4-3/4" Lag Screw (1/4-5/16" large washer)

## Step 6: Attach Brackets



**A:** On each middle Post Assembly place one Large Centre Roof Bracket, centred to each Long Beam Assembly so they are flush and tight to the inside face of each beam then attach to Post Assembly with two #12 x 1-1/2" Pan Screws per bracket. (F6.1 and F6.2)

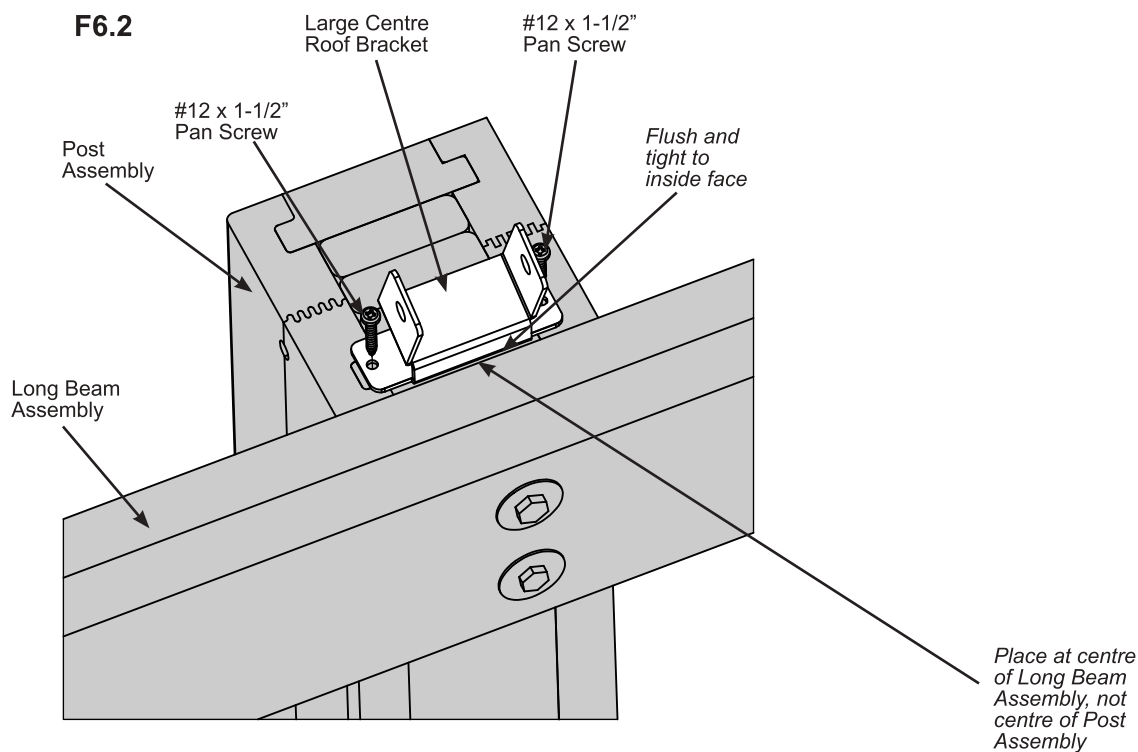
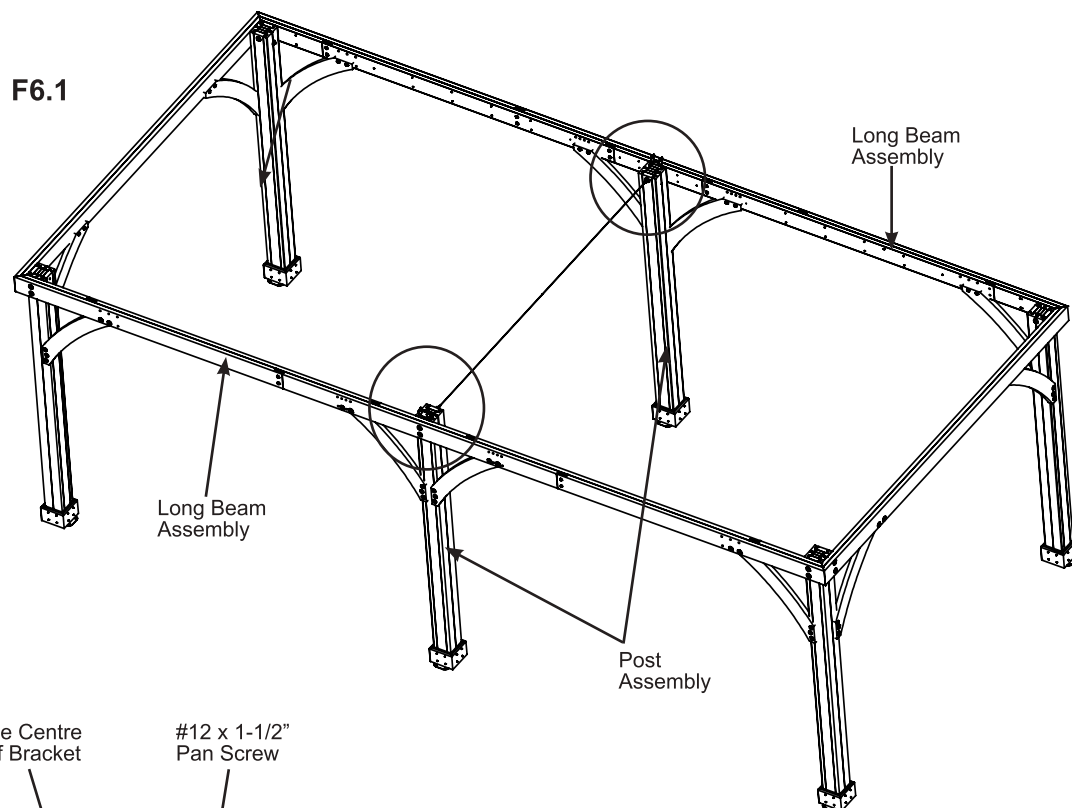

### Components

2 x Large Centre Roof Bracket

### Hardware

4 x #12 x 1-1/2" Pan Screw

## Step 7: Fascia Beam Assembly - Small Roof Rafter

**A:** Tightly connect one (627) Fascia Left Short and one (628) Fascia Right Short using one 5/16 x 1-1/2" Hex Bolt (with 5/16" lock washer, 1/4-5/16" large washer and 5/16" t-nut) as shown in F7.1 and F7.2. Repeat to make a second Fascia Beam Assembly.

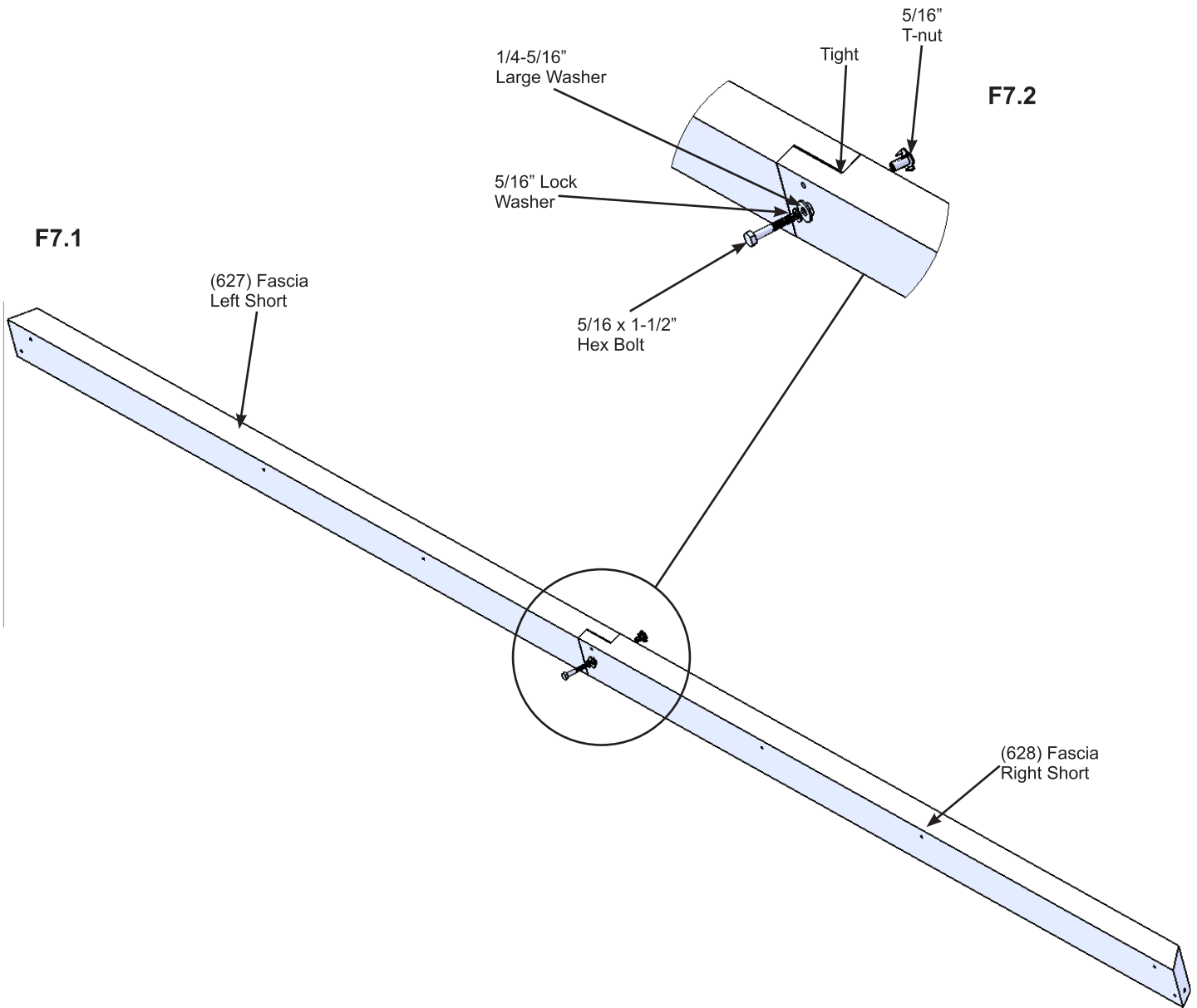

### Wood Parts

2 x (627) Fascia Left Short  
2 x (628) Fascia Right Short

### Hardware

2 x 5/16 x 1-1/2" Hex Bolt  
(5/16" lock washer, 1/4-5/16" large washer, 5/16" t-nut)

# Step 8: Small Roof Assembly Part 1

**A:** On each side of one (634) Rafter place one (624) Rafter Corner Left and one (623) Rafter Corner Right so the tops and edges are flush then attach with two #8 x 2-1/4" Wood Screws per side. (F8.1 and F8.2)

**B:** Place Fascia Beam Assembly from Step 7 on the bottom of (624) Rafter Corner Left, (623) Rafter Corner Right and (634) Rafter so the sides are flush then attach with one #8 x 2-1/2" Wood Screw at each end and one in the middle. (F8.1, F8.3, F8.4 and F8.5)

**C:** Repeat Steps A and B to make a second Small Roof Assembly.

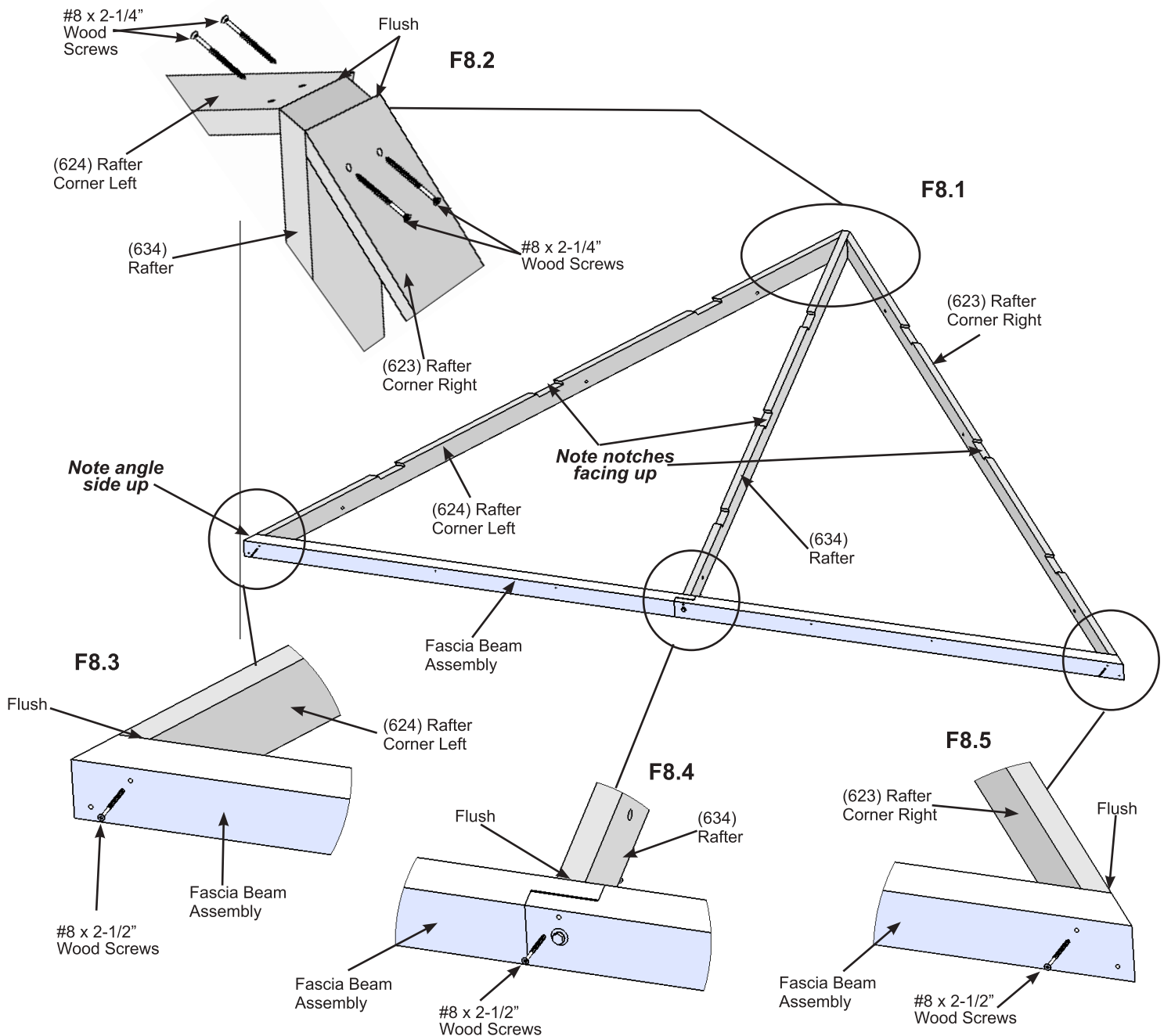

### Wood Parts

- 2 x (634) Rafter
- 2 x (623) Rafter Corner Right
- 2 x (624) Rafter Corner Left

### Hardware

- 8 x #8 x 2-1/4" Wood Screw
- 6 x #8 x 2-1/2" Wood Screw

# Step 8: Small Roof Assembly Part 2

**D:** Place one (629) Rafter Short RT, one (632) Rafter Centre RT, one (631) Rafter Centre LT and one (630) Rafter Short LT over the pilot holes in the Fascia Beam Assembly so they are flush to the top of the assembly and tight to both (623) Rafter Corner Right and (624) Rafter Corner Left, as shown in F8.6. Attach Fascia Beam Assembly to rafters with one #8 x 2-1/2" Wood Screw per rafter. Repeat for second Small Roof Assembly. (F8.6, F8.7 and F8.8)

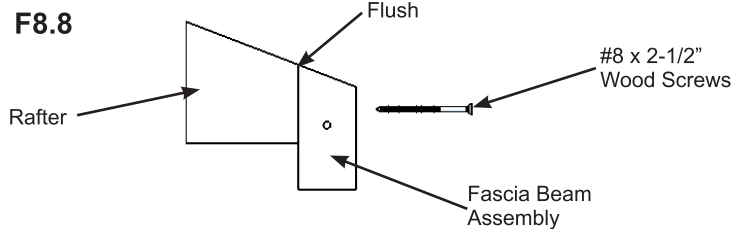
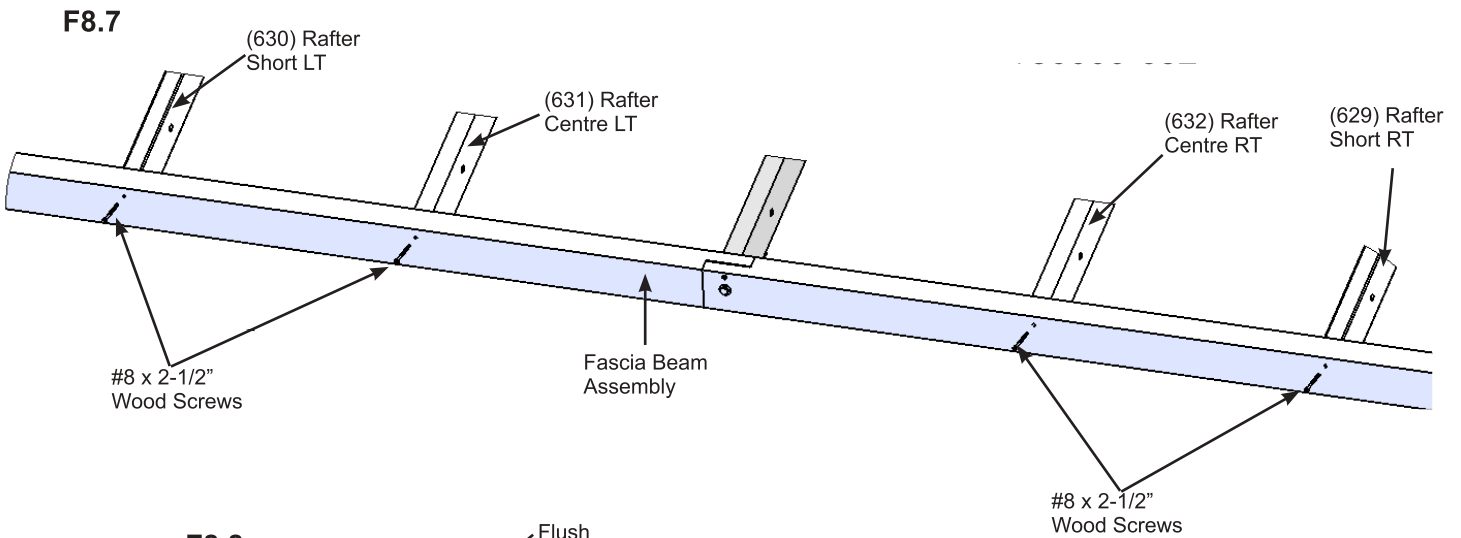
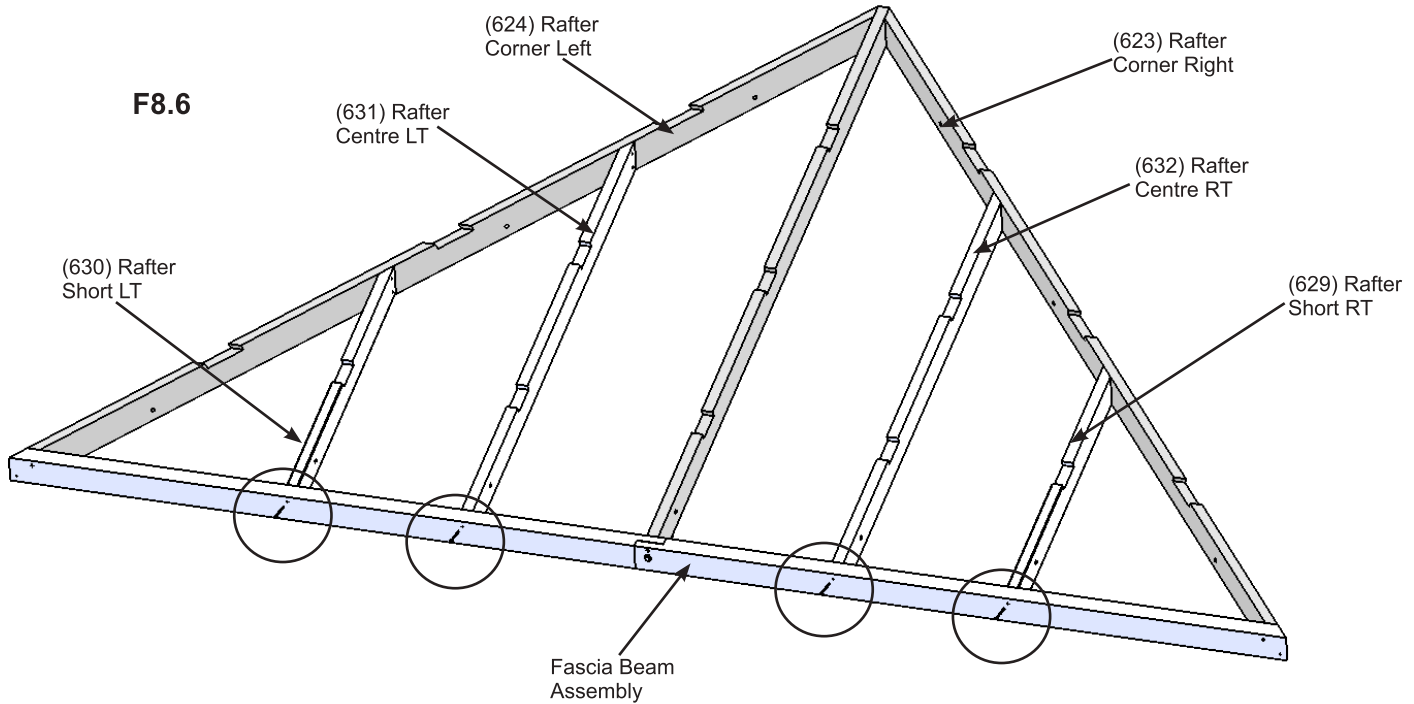

### Wood Parts

- 2 x (629) Rafter Short RT
- 2 x (630) Rafter Short LT
- 2 x (631) Rafter Centre LT
- 2 x (632) Rafter Centre RT

### Hardware

- 8 x #8 x 2-1/2" Wood Screw

# Step 8: Small Roof Assembly Part 3

**E:** Place one (636) Top Strap, one (637) Mid Strap, one (687) Bottom Strap LT and one (688) Bottom Strap RT in the notches of each rafter so the ends do not overhang the outside edges of the outside boards. (687) Bottom Strap LT and (688) Bottom Strap RT sit tight together. Attach with four #8 x 1-1/2" Wood Screws per strap. Complete for each Small Roof Assembly. (F8.9, F8.10 and F8.11)

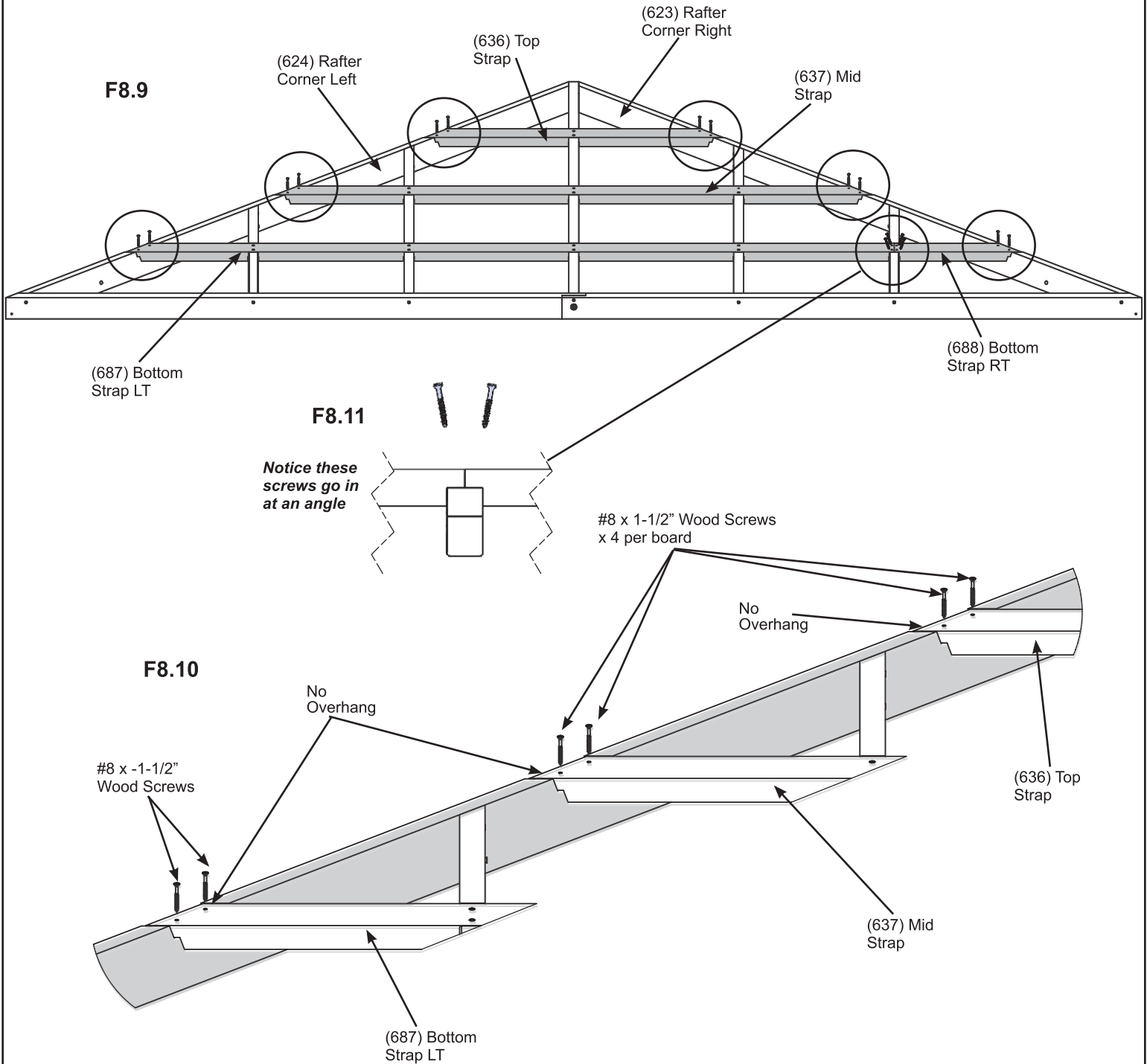

### Wood Parts

- 2 x (636) Top Strap
- 2 x (637) Mid Strap
- 2 x (687) Bottom Strap LT
- 2 x (688) Bottom Strap RT

### Hardware

- 32 x #8 x 1-1/2" Wood Screw

# Step 8: Small Roof Assembly

## Part 4

**F:** Attach (629) Rafter Short RT and (632) Rafter Centre RT to (623) Rafter Corner Right and (631) Rafter Centre LT and (630) Rafter Short LT to (624) Rafter Corner Left with two #8 x 1-1/2" Wood Screw per rafter. (F8.11 and F8.12)

**G:** Attach (636) Top Strap, (637) Mid Strap and (687) Bottom Strap LT to rafters with 16 #8 x 1-1/2" Wood Screws. (F8.13)

**H:** Complete Steps F and G for both Small Roof Assemblies.

**F8.11**

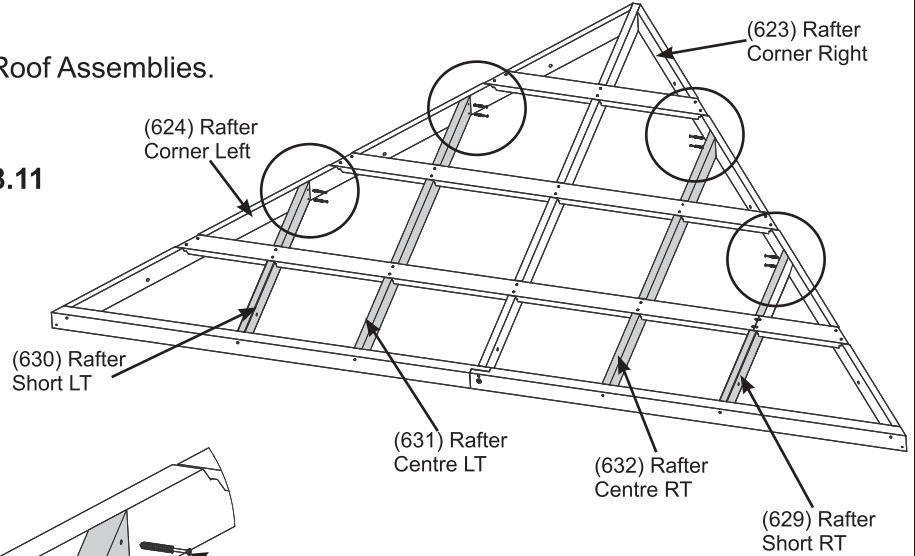

**F8.12**

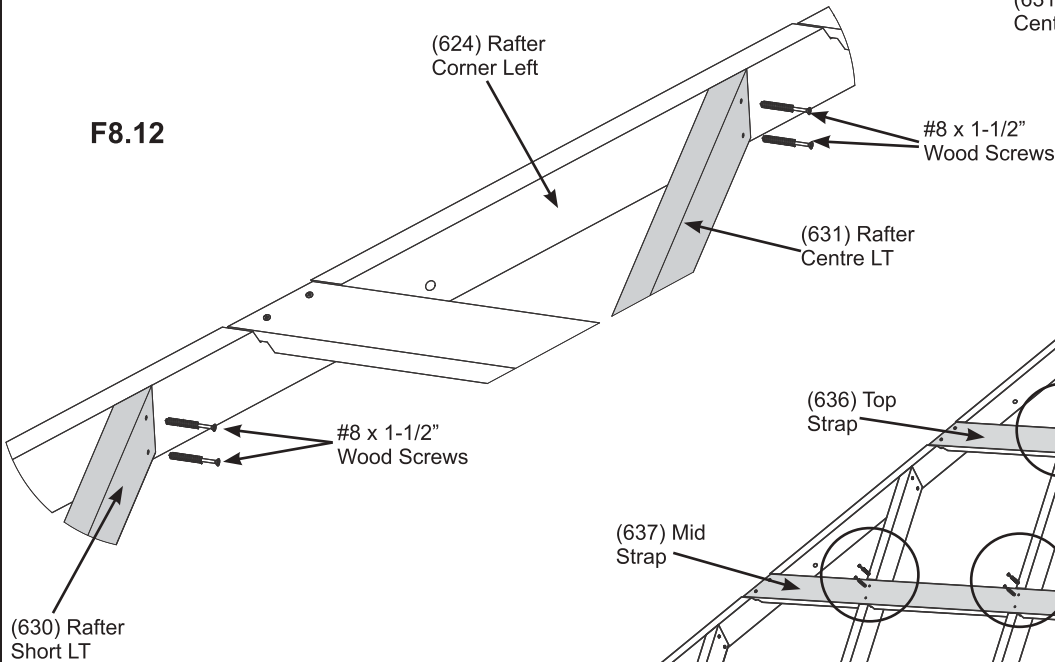

**F8.13**

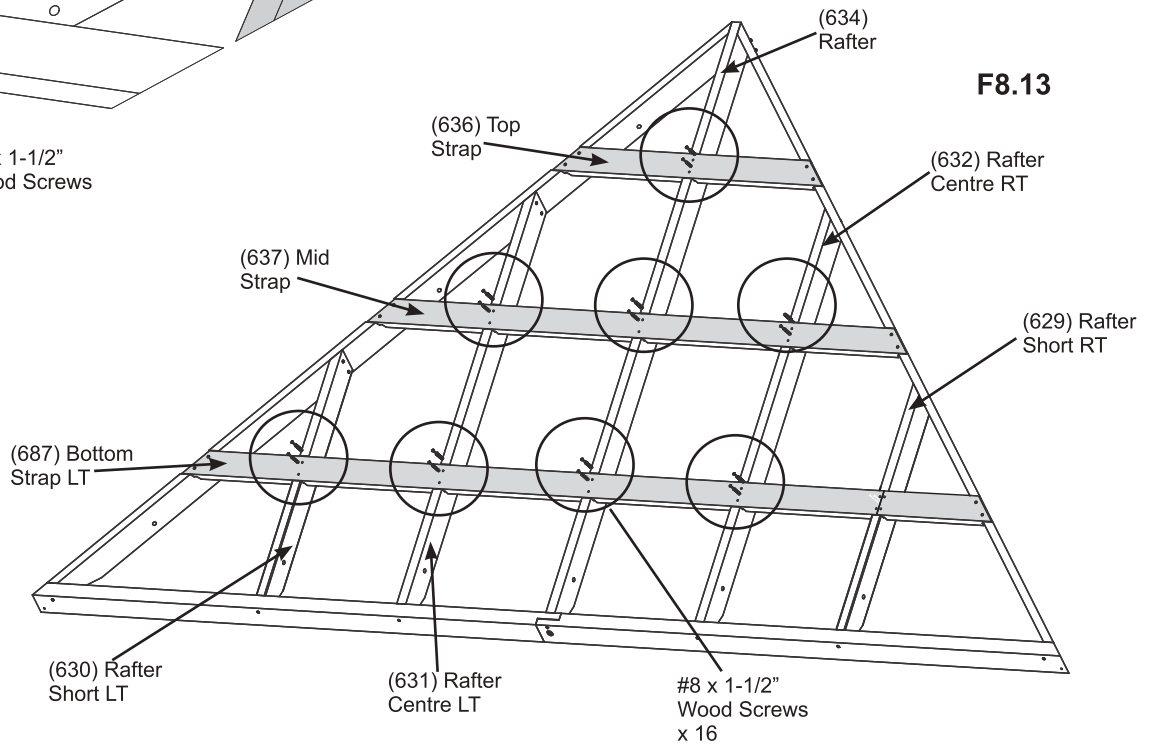

### Hardware

48 x #8 x 1-1/2" Wood Screw



# Step 9: Attach Soffits - Small Roof Assembly

**A:** Turn over each Small Roof Assembly then place two (648) Soffits tight together at centre of (634) Rafter and tight to the top of Fascia Beam Assembly. Attach (648) Soffits to (634) Rafter, (623) Rafter Corner Right, (624) Rafter Corner Left, (629) Rafter Short RT, (630) Rafter Short LT, (632) Rafter Centre RT and (631) Rafter Centre LT with four #8 x 1" Pan Screws per soffit. (F9.1 and F9.2)

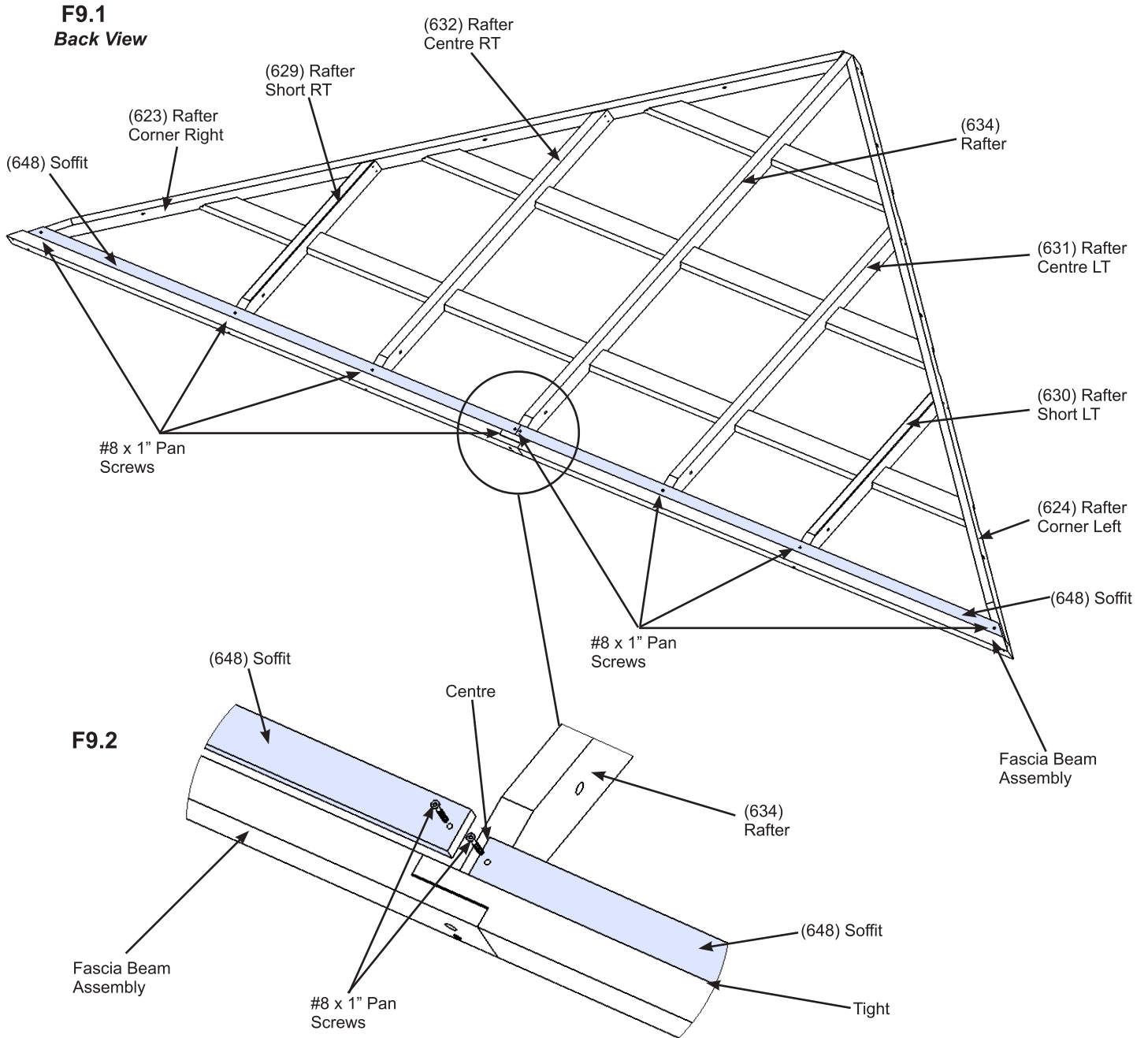

## Wood Parts

4 x (648) Soffit

## Hardware

16 x #8 x 1" Pan Screw

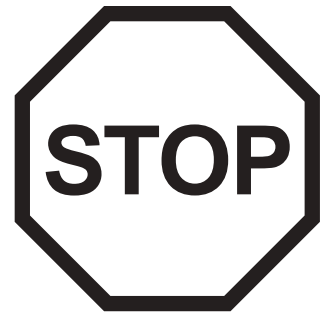
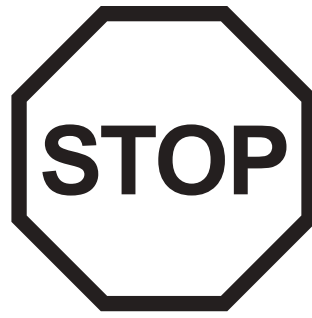

# INSTALLING ROOFING MATERIAL

---

## CAUTION!

Roofing material may have sharp edges! Wear gloves!

## HANDLE WITH CARE!

Place roofing material on a non-abrasive surface before assembly as it can bend, dent and scratch easily.

**WARNING – DO NOT OVER TIGHTEN ROOFING SCREWS!  
Over tightening screws will cause roofing material to crush.**

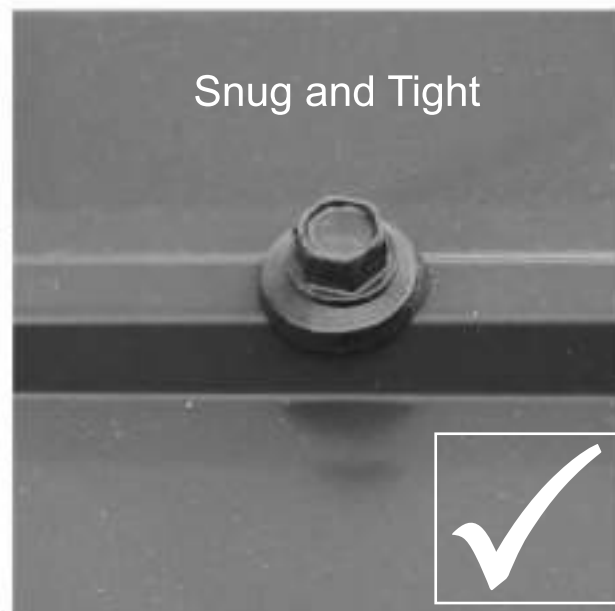
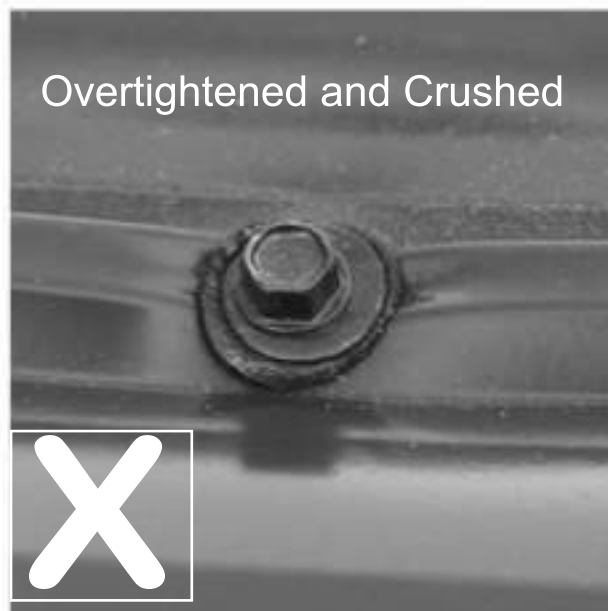

The roofing screws can easily crush the Roof Panels and Roof Edges when using a power drill. We recommend hand tightening the roofing screws so that they sit snug and tight to the roofing material.

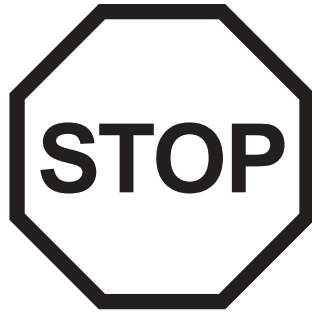
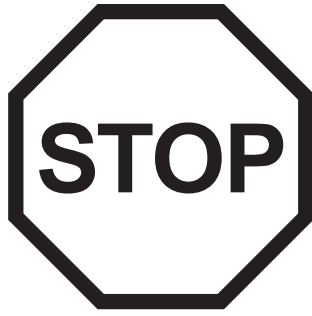
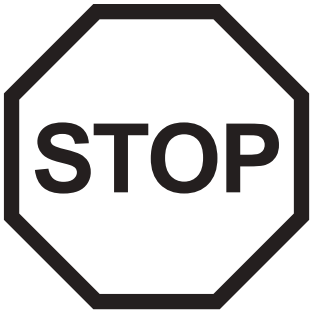

# INSTALLING ROOFING MATERIAL

---

## CAUTION!

Roofing material may have sharp edges! Wear gloves!

**BE SURE TO REMOVE ALL PLASTIC COVERING, ON BOTH SIDES OF THE ALUMINUM PANELS AND TRIM, DIRECTLY BEFORE INSTALLING EACH PIECE. *(One side is clear and the other is blue, both must be removed.)***

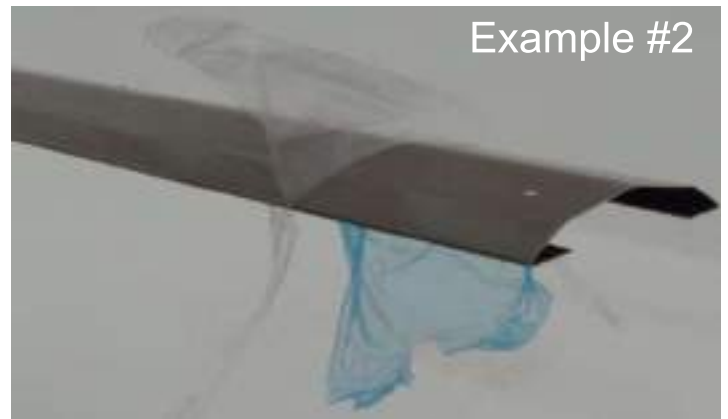
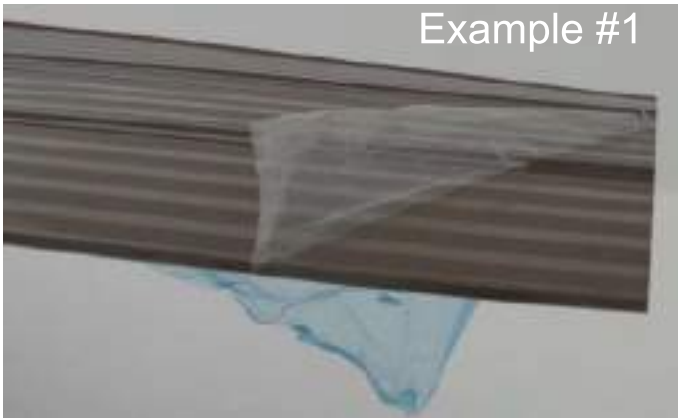

# Step 10: Attach Roof Panels - Small Roof Assembly Part 1

**A:** Place one Long Panel Left on the front of one Small Roof Assembly so it is flush to the side of (624) Rafter Corner Left and a slight overhang at the bottom of the Fascia Beam Assembly. Centre holes should line up with (634) Rafter. (F10.1 and F10.2)

**B:** Place one Long Panel Right on Small Roof Assembly so it overlaps the Long Panel Left and it is flush to the side of (623) Rafter Corner Right and a slight overhang at the bottom of the Fascia Beam Assembly. (F10.1, F10.2 and F10.3)

**C:** Attach both Left and Right Long Panels to Small Roof Assembly with four #8 x 1" Roofing Screws in locations shown in F10.1 and F10.2. Be sure not to overtighten screws.

**D:** Repeat Steps A - C for both Small Roof Assemblies.

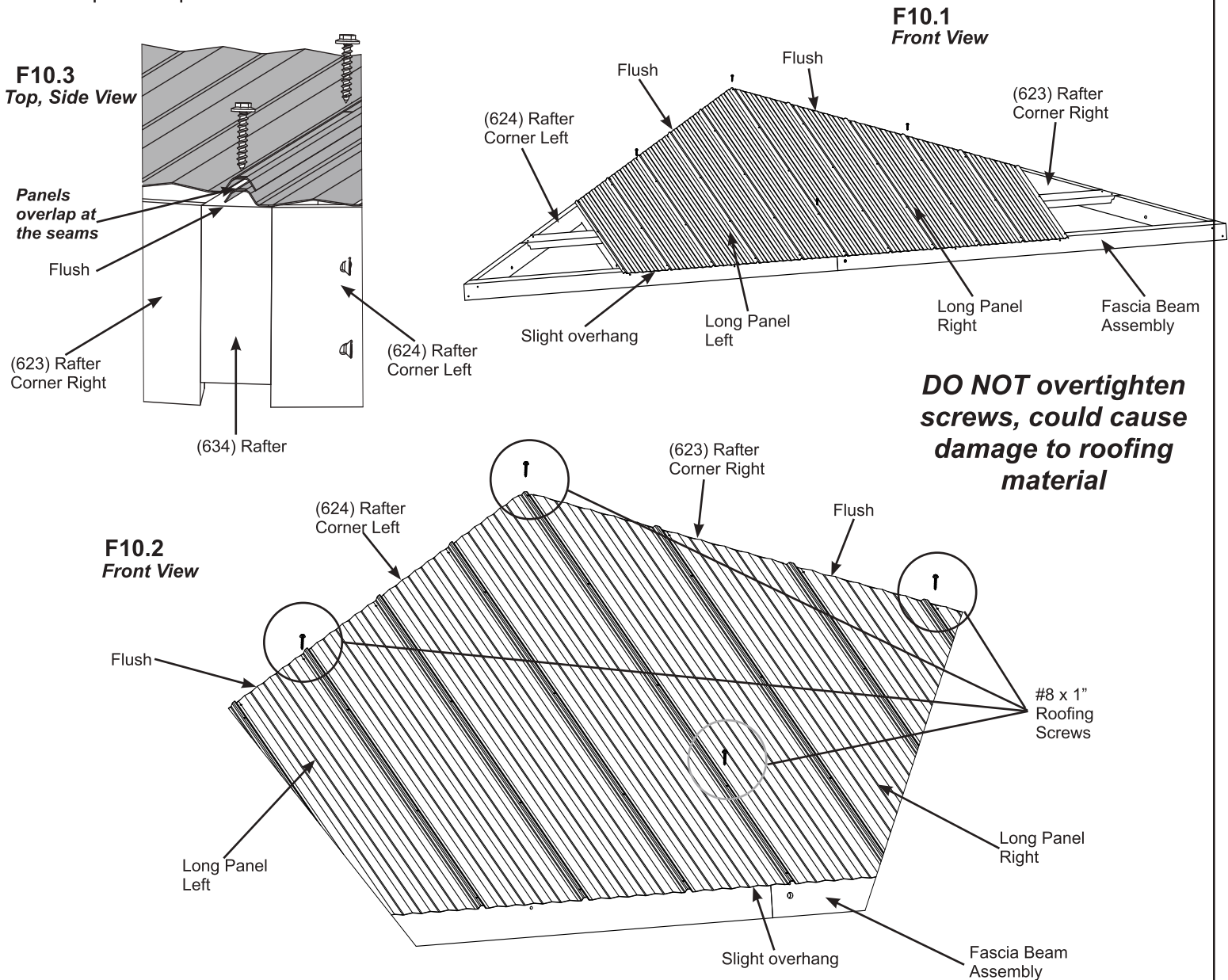

## Roof Parts

- 2 x Long Panel Left
- 2 x Long Panel Right

## Hardware

- 8 x #8 x 1" Roofing Screw

# Step 10: Attach Roof Panels - Small Roof Assembly Part 2

**E:** Place one Short Panel Left on Small Roof Assembly so it overlaps the Long Panel Left and it is flush to the sides of (624) Rafter Corner Left and a slight overhang at the bottom of the Fascia Beam Assembly. There should be no overhang at the corners. (F10.4 and F10.5)

**F:** Place one Short Panel Right on Small Roof Assembly so it overlaps the Long Panel Right and it is flush to the side of (623) Rafter Corner Right and a slight overhang at the bottom of the Fascia Beam Assembly. There should be no overhanging at the corners. (F10.4 and F10.5)

**G:** Attach all panels to Small Roof Assembly with 40 #8 x 1" Roofing Screws in locations shown in F10.4. Do not place any screws along the bottom row. Be sure not to overtighten screws.

**H:** Repeat Steps E - G for both Small Roof Assemblies.

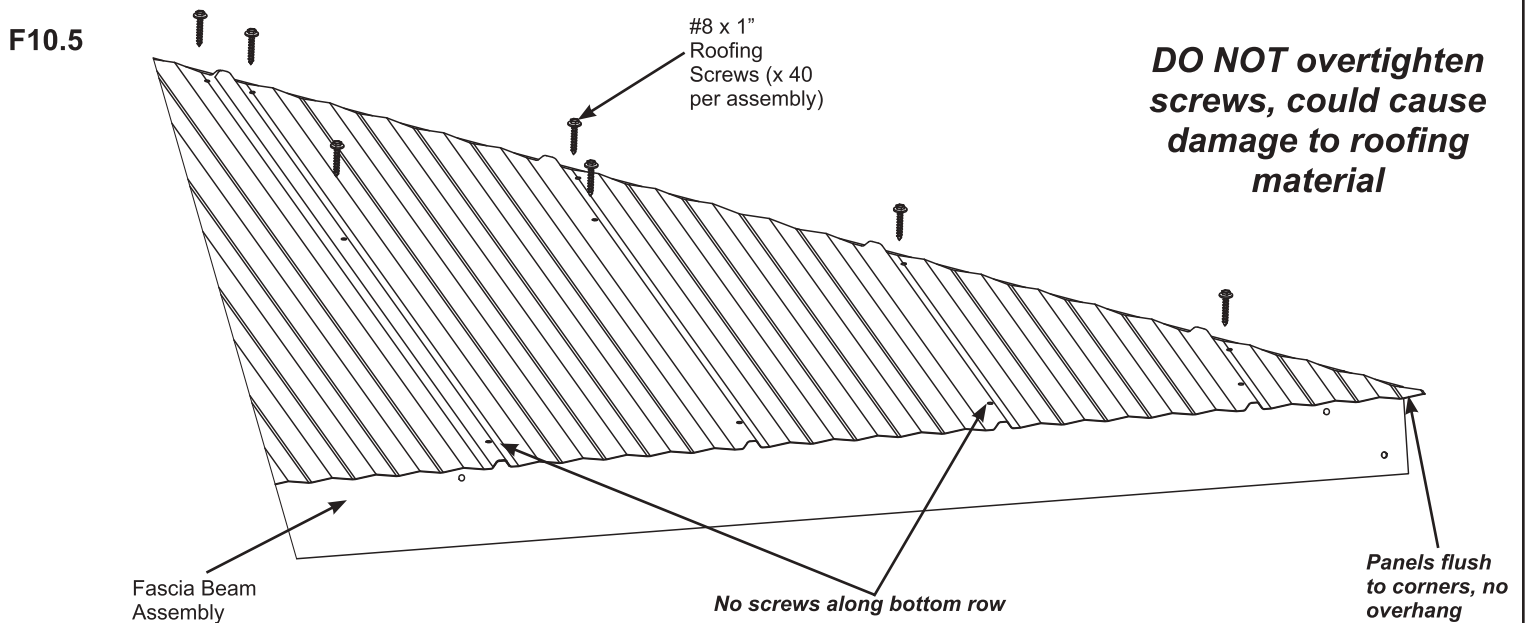
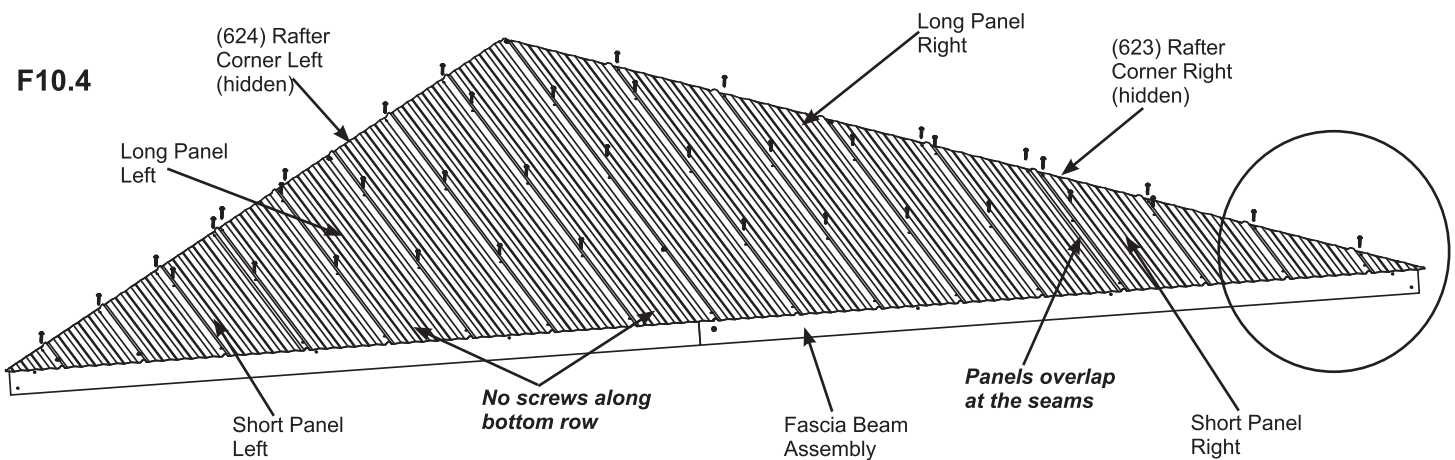

### Roof Parts

- 2 x Short Panel Left
- 2 x Short Panel Right

### Hardware

- 80 x #8 x 1" Roofing Screw

# Step 11: Attach Ridge Clips and Roof Edges - Small Roof



**A:** Place one Roof Edge Left 72.2 and one Roof Edge Right 72.2 on the bottom of each Small Roof Rafter Assembly so the ends are flush with the outside ends of the Fascia Beam Assembly and meet tight in the centre. Attach both Roof Edges with 17 #8 x 1" Roofing Screws per Small Roof Rafter assembly. (F11.1 and F11.2)

**B:** Place one Weather Seal on the inside of four Ridge Clip 102.5 then place one Ridge Clip 102.5 on each side of each Small Roof Rafter Assembly so they cover the panels and bottom edge is 2-3/4" (6.985 cm) up from the bottom of the Corner Rafters then attach with five #7 x 3/4" Wood Screws per Ridge Clip 102.5. (F11.1, F11.3 and F11.4)

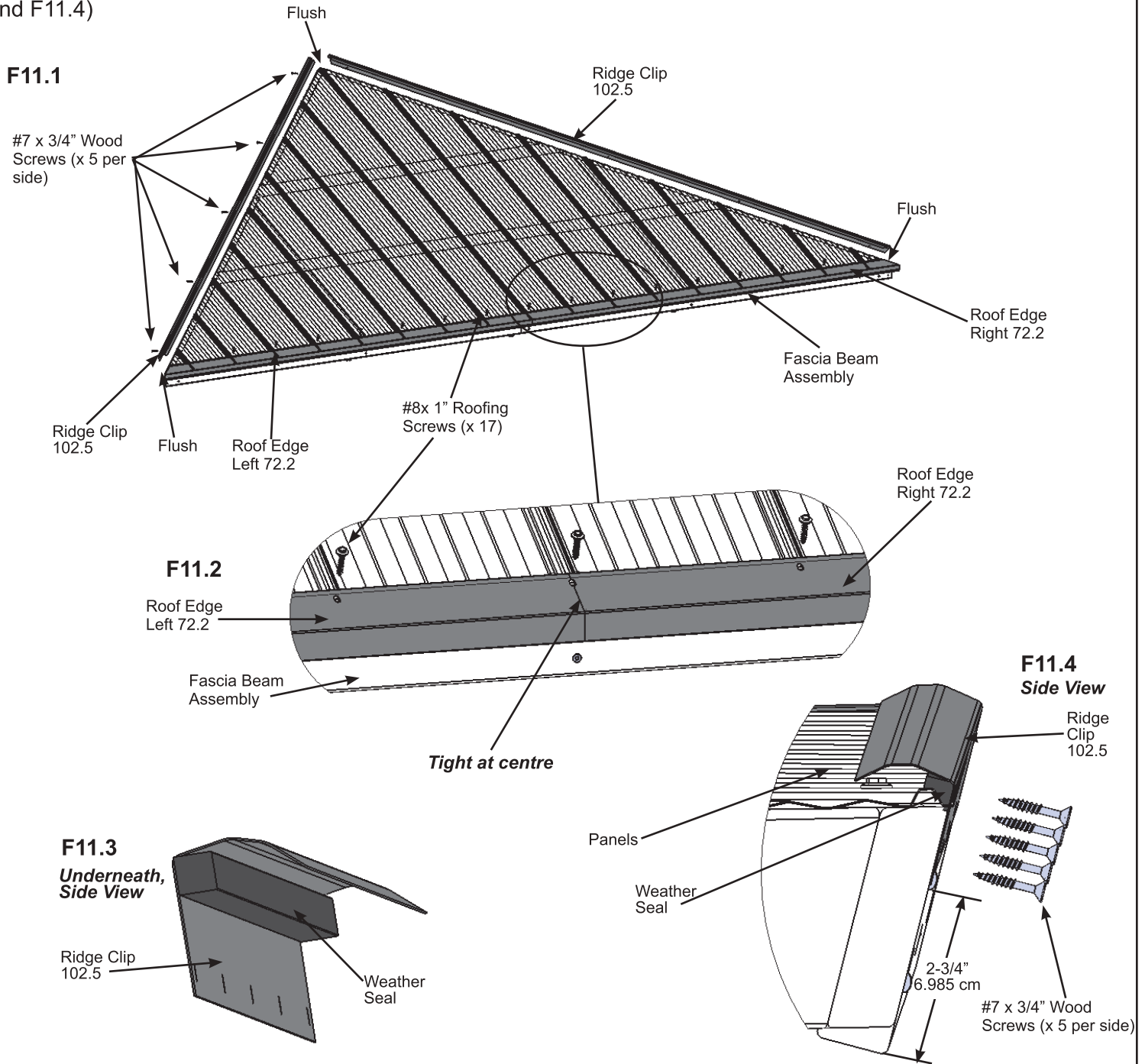

### Components

- 2 x Roof Edge Left 72.2
- 2 x Roof Edge Right 72.2
- 4 x Ridge Clip 102.5
- 4 x Weather Seal

### Hardware

- 34 x #8 x 1" Roofing Screw
- 20 x #7 x 3/4" Wood Screw

# Step 12: Corner Roof Assemblies

## Part 1

**A:** On the left side of one (675) Middle Rafter place one (624) Rafter Corner Left so the tops and edges are flush, notice on the (675) Middle Rafter the angled end at the bottom slopes down then attach with two #8 x 2-1/4" Wood Screws. Repeat this step by attaching one (623) Rafter Corner Right on the right side of one (675) Middle Rafter. (F12.1, F12.2 and F12.3)

**B:** Place one (676) Left End Fascia on the bottom of (624) Rafter Corner Left and (675) Middle Rafter so the tops and edges are flush then attach with two #8 x 2-1/2" Wood Screws. Repeat this step by attaching one (677) Right End Fascia to (623) Rafter Corner Right and (675) Middle Rafter. (F12.1, F12.2, F12.4 and F12.5)

**C:** Repeat Steps A and B to make a total of two Left Corner Roof Assemblies and two Right Corner Roof Assemblies.

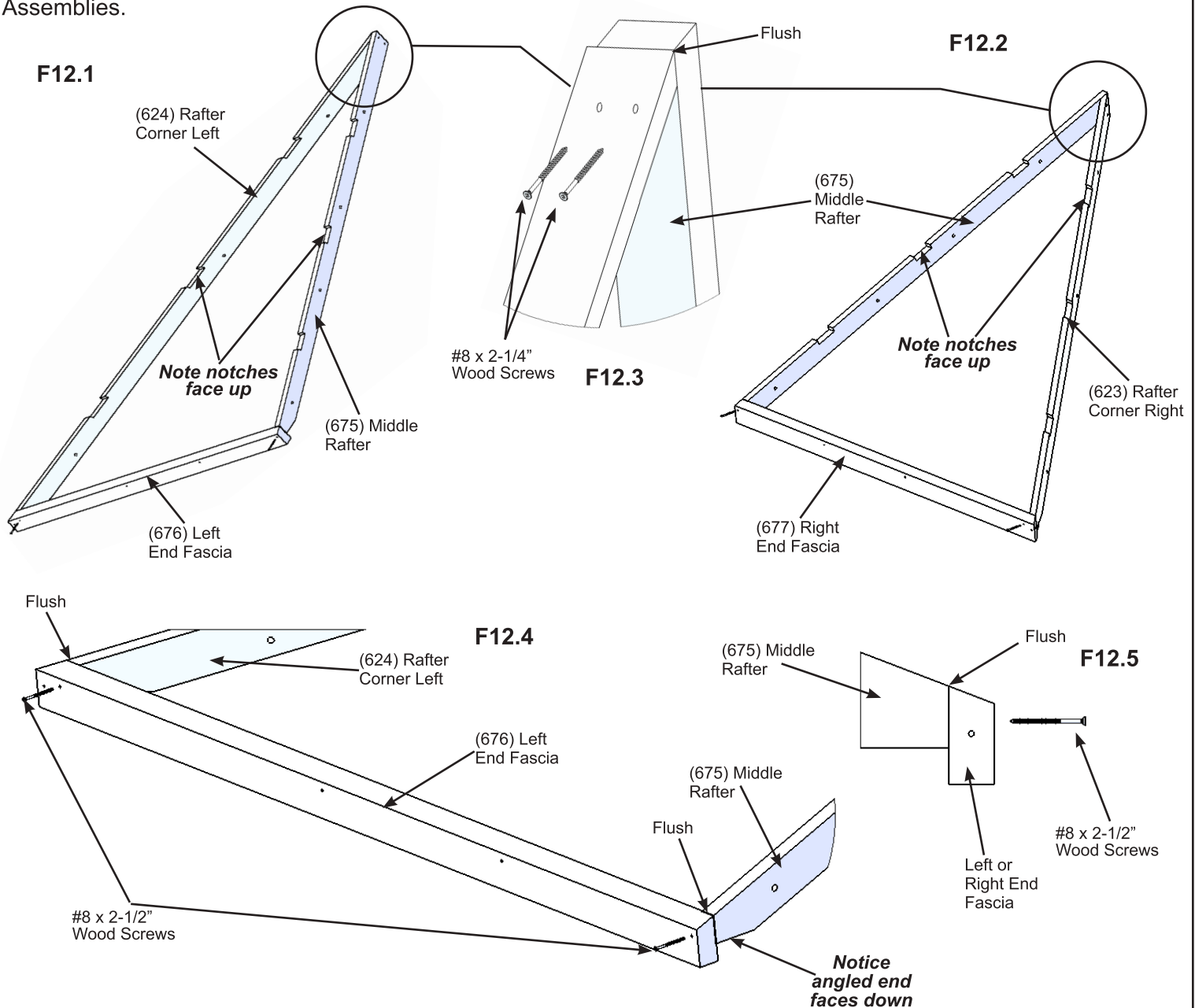

### Wood Parts

- 4 x (675) Middle Rafter
- 2 x (623) Rafter Corner Right
- 2 x (624) Rafter Corner Left
- 2 x (676) Left End Fascia
- 2 x (677) Right End Fascia

### Hardware

- 8 x #8 x 2-1/4" Wood Screw
- 8 x #8 x 2-1/2" Wood Screw

# Step 12: Corner Roof Assemblies

## Part 2

**D:** For each Right Corner Roof Assembly and each Left Corner Roof Assembly, place one (629) Rafter Short RT, one (632) Rafter Centre RT, one (631) Rafter Centre LT and one (630) Rafter Short LT over the pilot holes in the (677) Right End Fascia and (676) Left End Fascia so they are flush to the top of the assembly and tight to both (623) Rafter Corner Right and (624) Rafter Corner Left, as shown in F12.6 and F12.7. Attach each End Fascia to each rafter with one #8 x 2-1/2" Wood Screw per rafter. (F12.6, F12.7, F12.8 and F12.9)

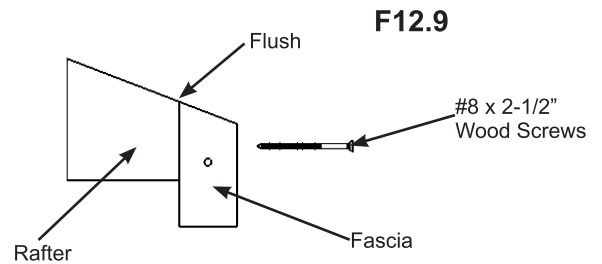
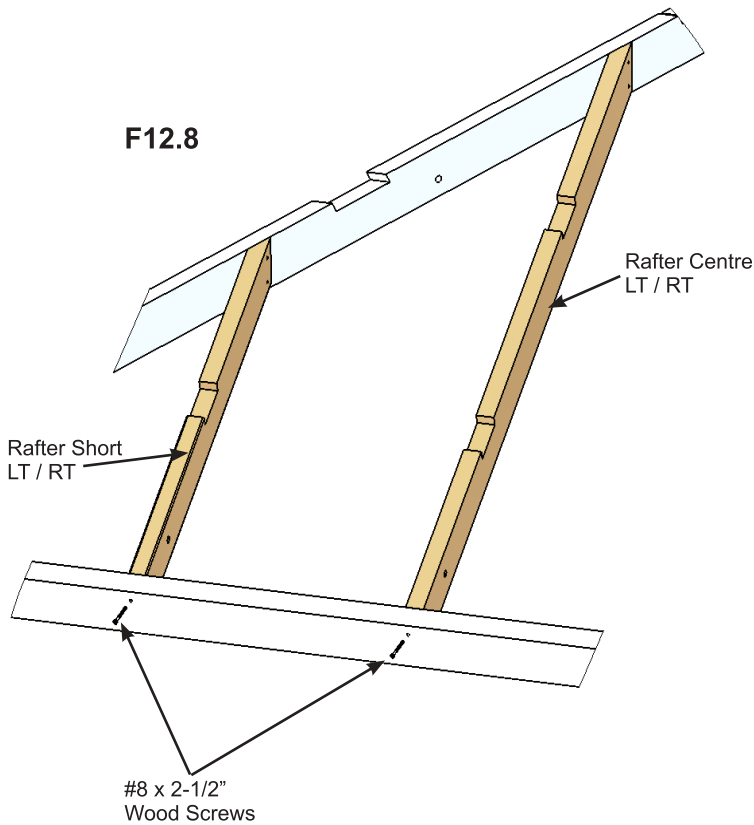
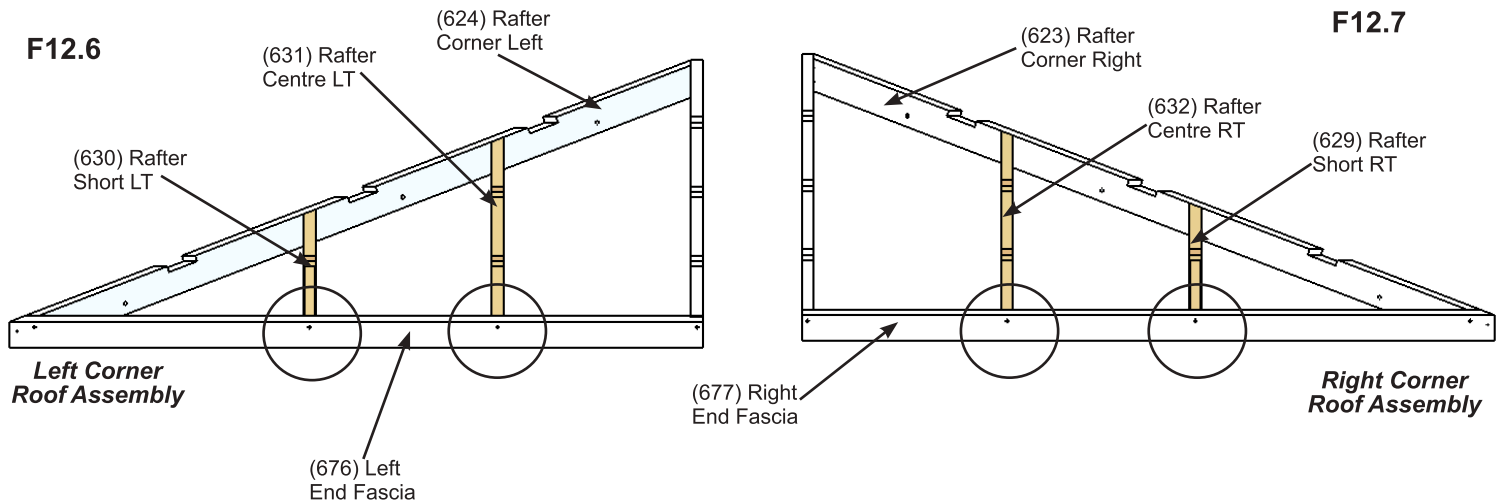

### Wood Parts

- 2 x (629) Rafter Short RT
- 2 x (630) Rafter Short LT
- 2 x (631) Rafter Centre LT
- 2 x (632) Rafter Centre RT

### Hardware

- 8 x #8 x 2-1/2" Wood Screw