

# Step 9: Long Beam/Post Assembly Part 3



**E:** At the end of the lap on (1358) Left Long Beam, measure 16-5/8" (42.25 cm) and mark the center of both Long Beam Assemblies. (F9.9)

**F:** With a helper lift the Center Beam Assembly onto the Mid Post Assemblies so the holes in the Mid Post Brackets line up with the holes in (1359) Long Beam Center and the (1367) Center Beam Middle lines up with the mark. (F9.7, F9.8 and F9.9)

**F9.7**

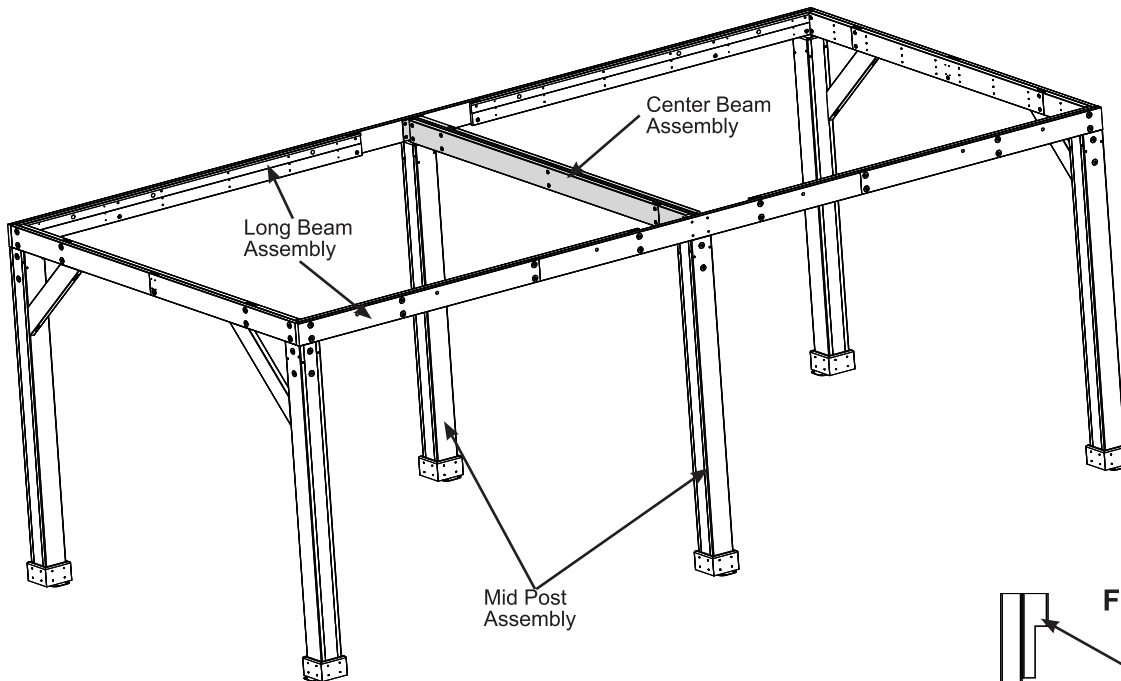

**F9.8  
Inside View**

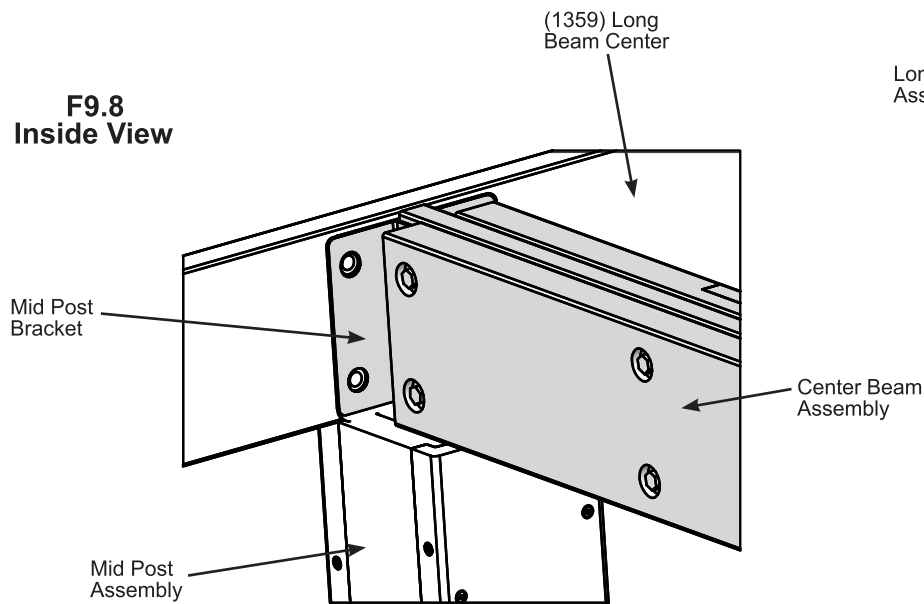

**F9.9**

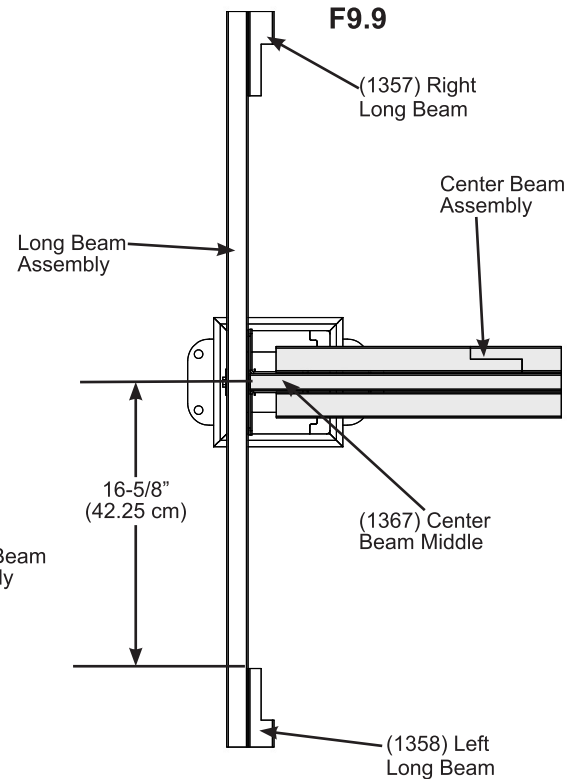

# Step 9: Long Beam/Post Assembly Part 4



**F:** On two (1360) Long Beam Center LT and two (1361) Long Beam Center RT tap two 5/16" T-nuts into each end. T-nuts should be installed on the same side as the groove. (F9.11 and F9.12)

**G:** Place (1360) Long Beam Center LT and (1361) Long Beam Center RT on each side of the Center Beam Assembly so the holes align and the laps are tight. Attach with two 5/16 x 2-3/4" Hex Bolts (with 5/16" lock washer and 1/4-5/16" large washer) in the bottom holes and two 5/16 x 2-1/2" Hex Bolts (with 5/16" lock washer and 1/4-5/16" large washer) in the top hole per board. The bolts will connect to the previously installed t-nuts. (F9.10 and F9.12)

**F9.10**

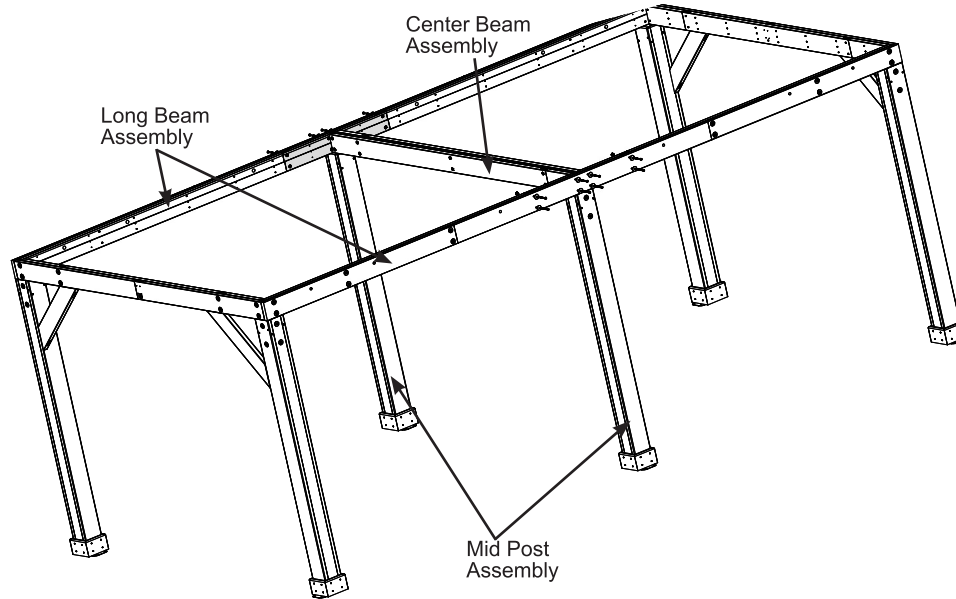

**F9.11**

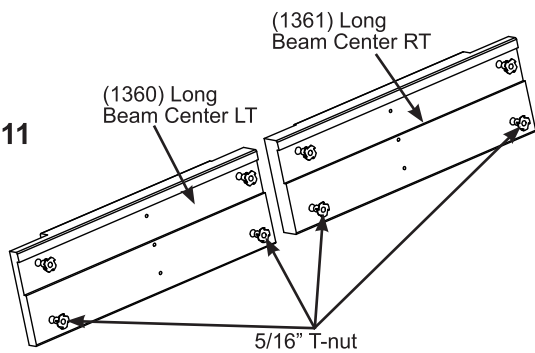

**F9.12  
Inside View**

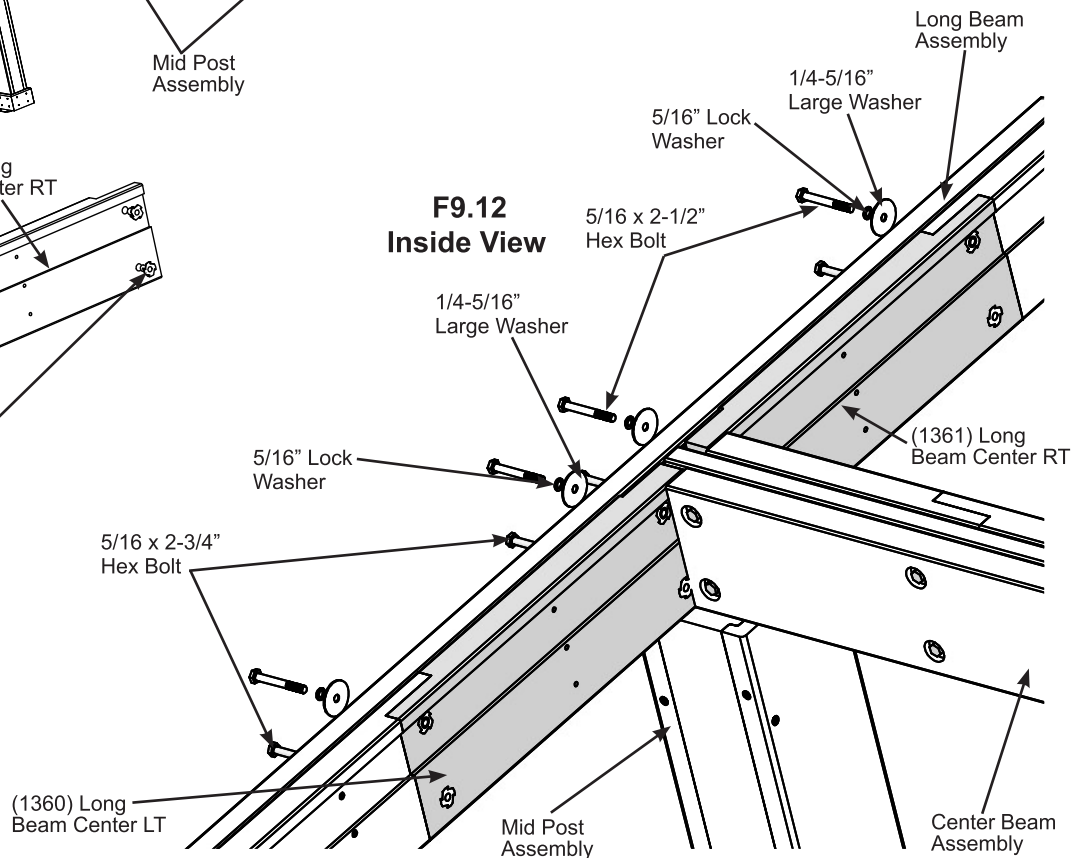

### Wood Parts

- 2 x (1360) Long Beam Center LT
- 2 x (1361) Long Beam Center RT

### Hardware

- 8 x 5/16 x 2-1/2" Hex Bolt  
(5/16" lock washer, 1/4-5/16" large washer, 5/16" t-nuts)
- 8 x 5/16 x 2-3/4" Hex Bolt  
(5/16" lock washer, 1/4-5/16" large washer, 5/16" t-nuts)

# Step 9: Long Beam/Post Assembly Part 5



**H:** From inside the assembly install three #8 x 2-1/4" Wood Screws to each (1360) Long Beam Center LT and (1361) Long Beam Center RT. (F9.13 and F9.14)

**I:** From inside the assembly install six #8 x 2-1/4" Wood Screws to the ends of each Long Beam Assembly and three #8 x 2-1/2" Wood Screws to the ends of each Short Beam Assembly. (F9.13 and F9.15)

**F9.13**

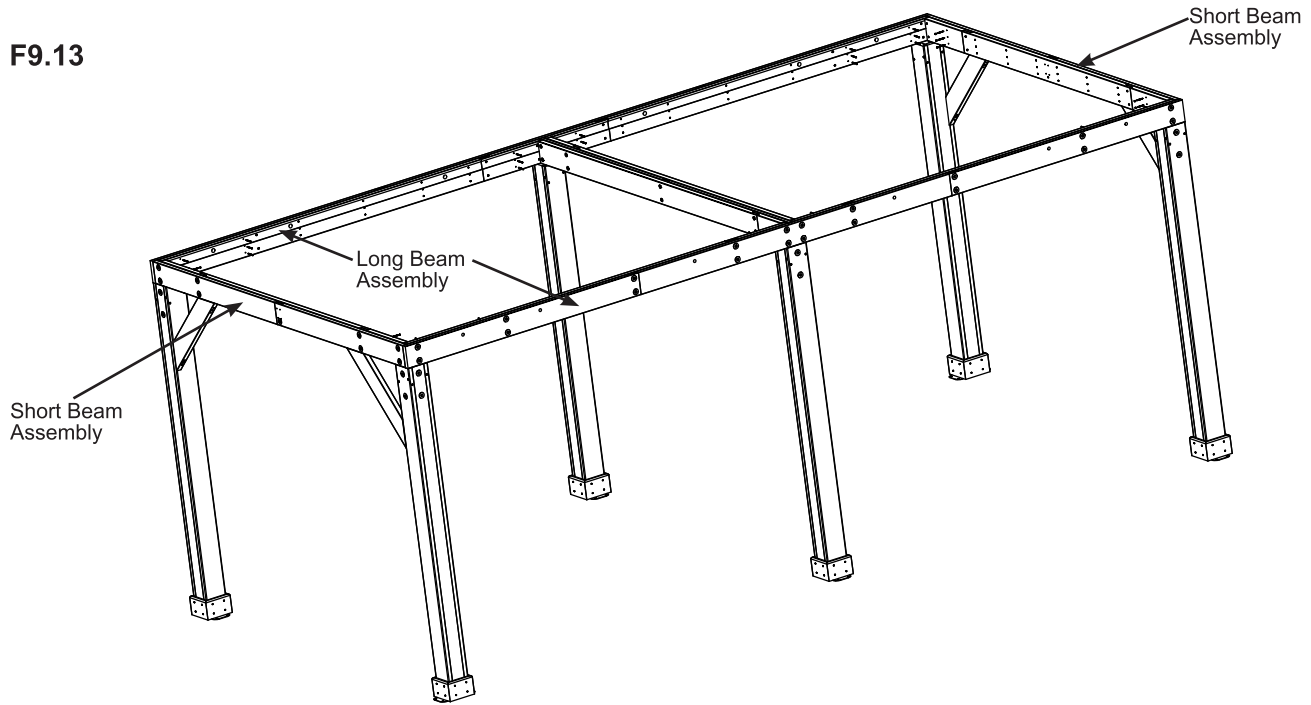

**F9.14**

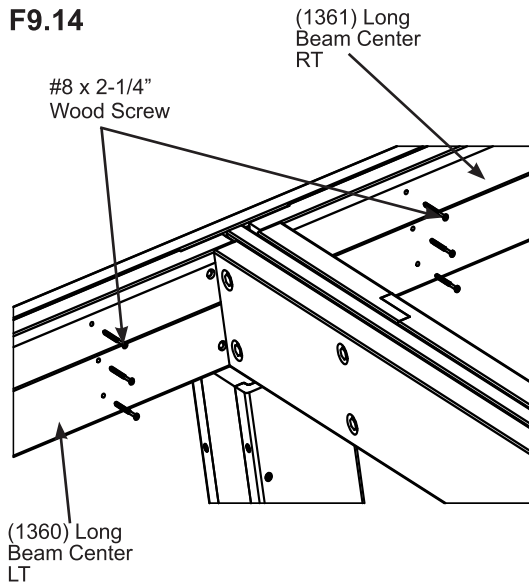

**F9.15**

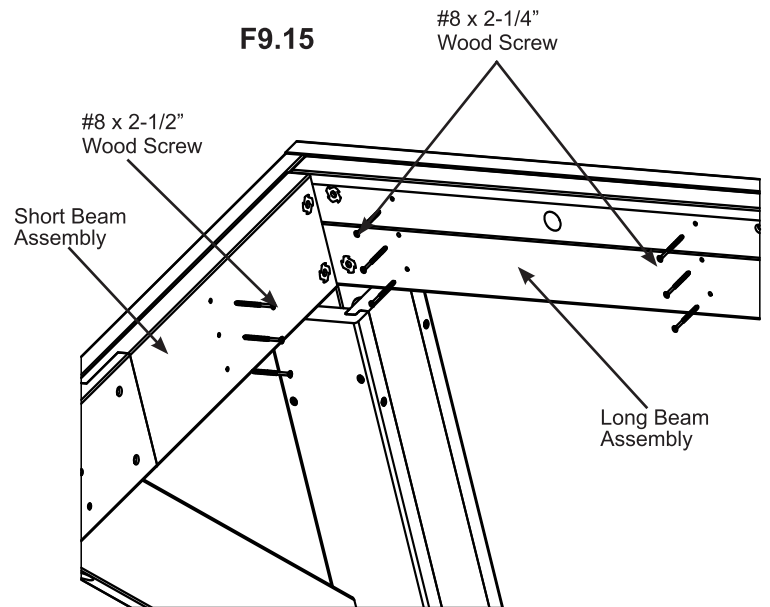

## Hardware

36 x #8 x 2-1/4" Wood Screw

12 x #8 x 2-1/2" Wood Screw

# Step 9: Long Beam/Post Assembly Part 6



**J:** Place one (1333) Gusset flush to front of Long Beam Assembly and flush to the front of the Post and Mid Post. Attach gusset to Long Beam Assembly, Post and Mid Post with two #8 x 3-1/2" Wood Screws. Pre-drill with a 1/8" drill bit then attach gusset with two 5/16 x 4-3/4" Lag Screws (with 5/16" flat washer). (F9.16, F9.17 and F9.18)

**F9.16**  
Front View

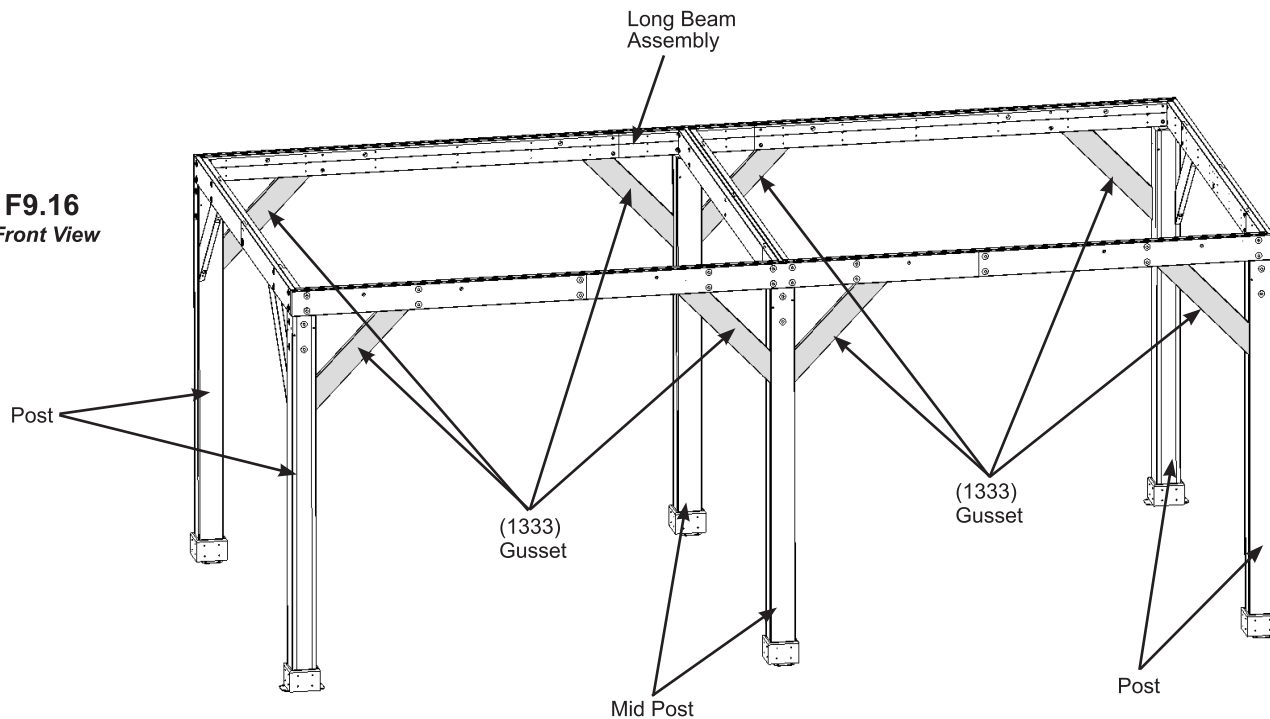

**F9.17**

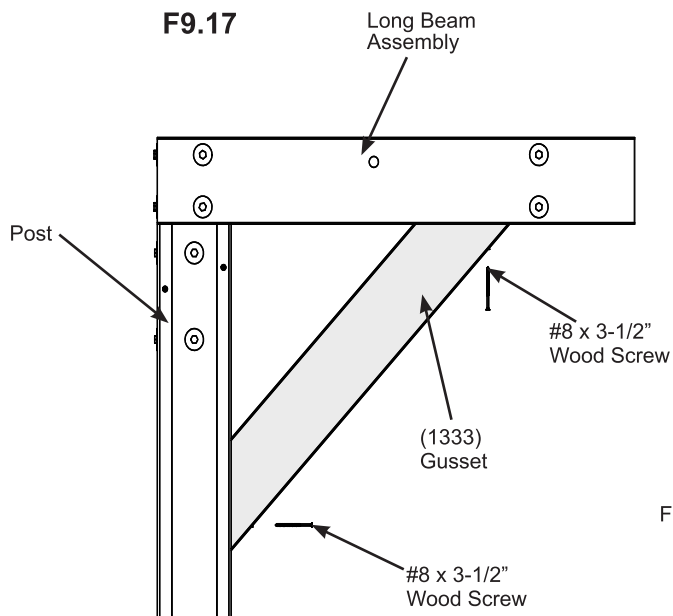

**F9.18**

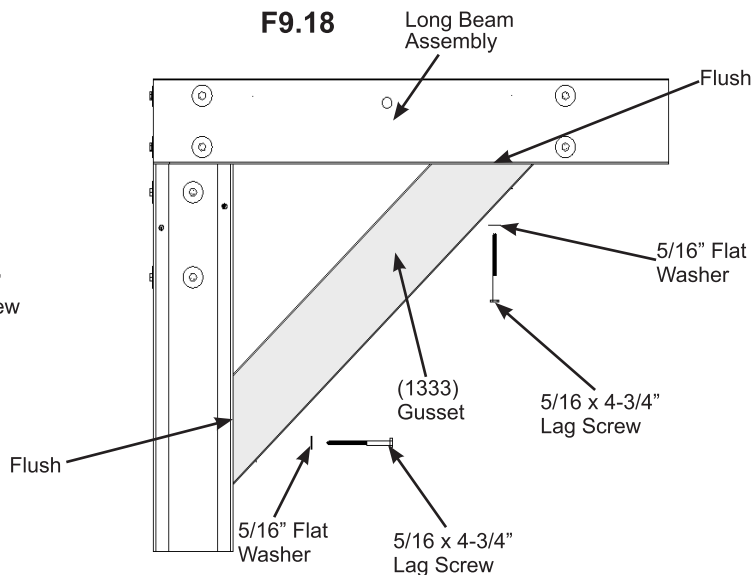

### Wood Parts

8 x (1333) Gusset

### Hardware

16 x #8 x 3-1/2" Wood Screw

16 x 5/16 x 4-3/4" Lag Screw (5/16" flat washer)

# Step 9: Long Beam/Post Assembly Part 7



**K:** Place one (1333) Gusset centered to the Mid Post and Center Beam Assembly. Attach gusset to Mid Post and Center Beam Assembly with two #8 x 3-1/2" Wood Screws. Pre-drill with a 1/8" drill bit then attach gusset with two 5/16 x 4-3/4" Lag Screws (with 5/16" flat washer). (F9.19, F9.20 and F9.21)

F9.19

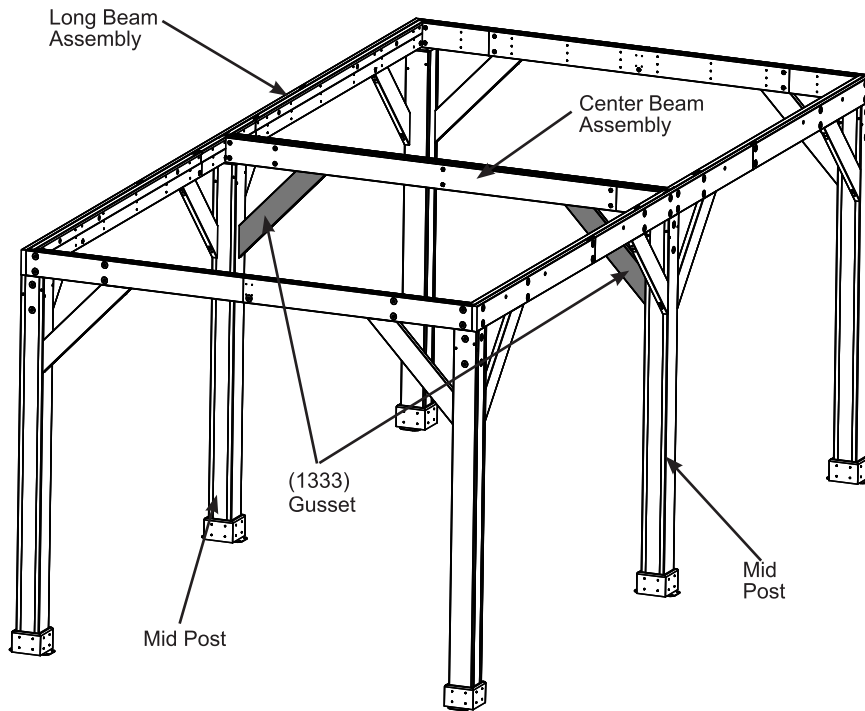

F9.20

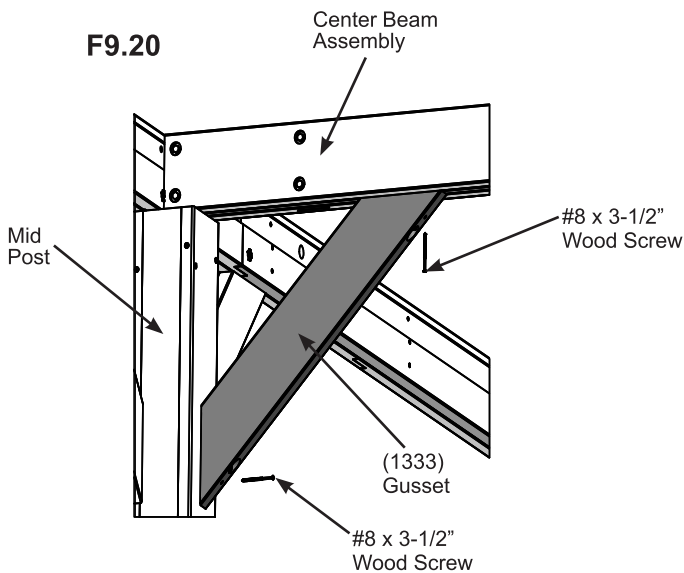

F9.21

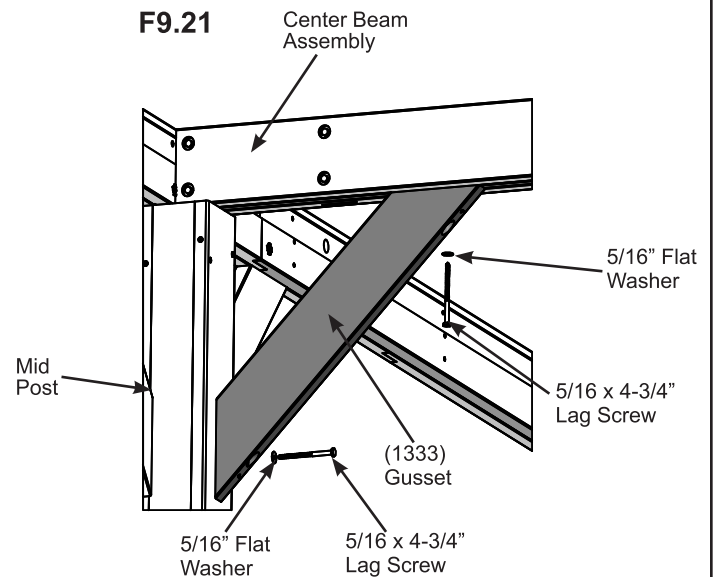

### Wood Parts

2 x (1333) Gusset

### Hardware

4 x #8 x 3-1/2" Wood Screw

4 x 5/16 x 4-3/4" Lag Screw (5/16" flat washer)

# Step 10: Check Frame Dimensions



**A:** The diagonal distance between the inside of two posts should be 20'-11 15/16" (6.399 m) (measuring from posts not from Post Mounts. (F10.1)

## F10.1

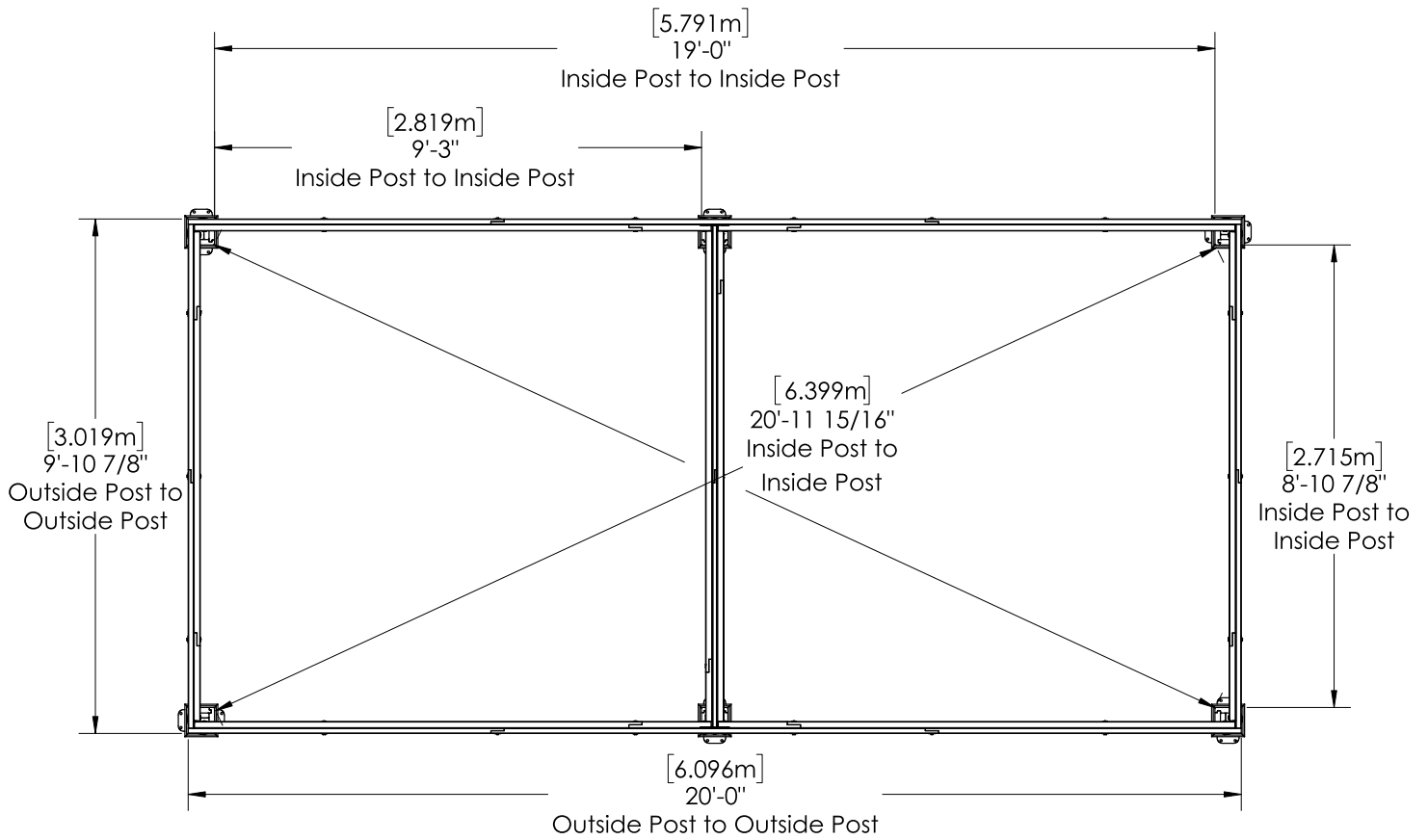

# Step 11: Attach Middle Beam Assembly Part 1



**A:** On each Short Beam Assembly, at the lap where two (1364) Short Side Beams meet, measure 1-1/2" (3.81 cm) and mark the spot. On Center Beam Middle, at the lap where two (1367) Center Beam Middles meet, measure 1-1/2" (3.81 cm) and mark the spot. (F11.1 and F11.2)

**B:** Place two Middle Beam Assemblies at the centre of Short Beam Assembly and Center Beam Assembly so the middle of Mid Beam Bracket lines up with the previously marked location on the Short Beam Assembly and Center Beam Assembly. Make sure Axle Through Pin Shorts are at the top of the beam. They will be aligned with the holes for the Crank. Attach Mid Beam Bracket to Short Beam Assemblies and Center Beam Assembly with six #8 x 1-1/2" Wood Screws per bracket. (F11.3, F11.4 and F11.5)

**F11.1**  
Top View

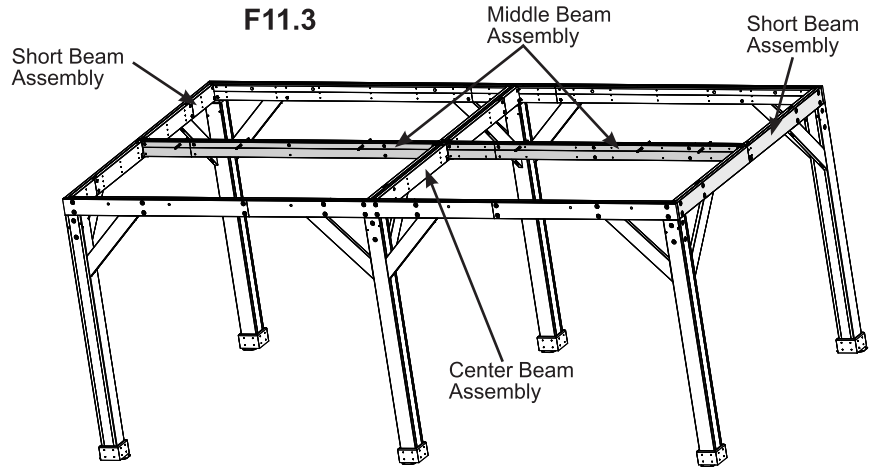
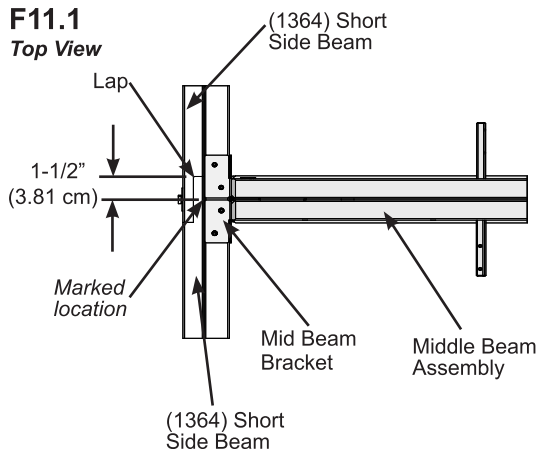

**F11.2**

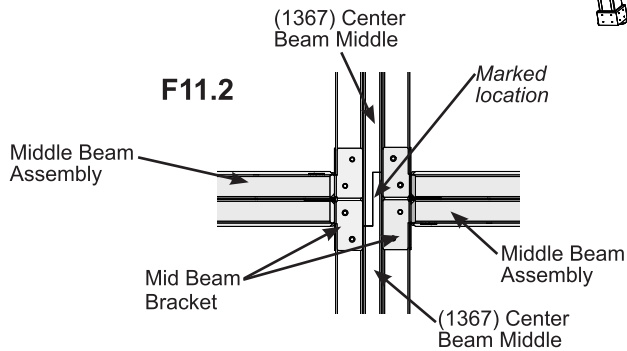

**F11.5**  
Inside View

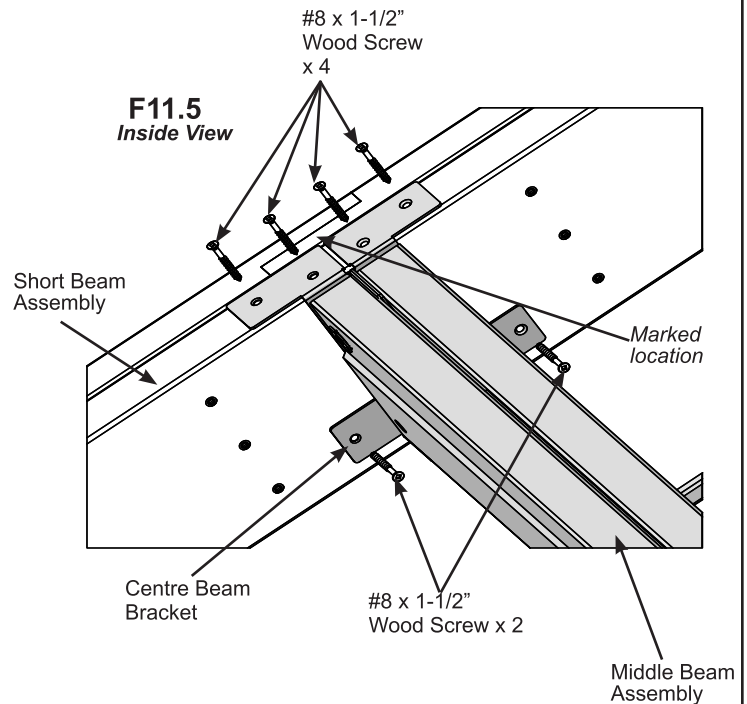

**F11.4**

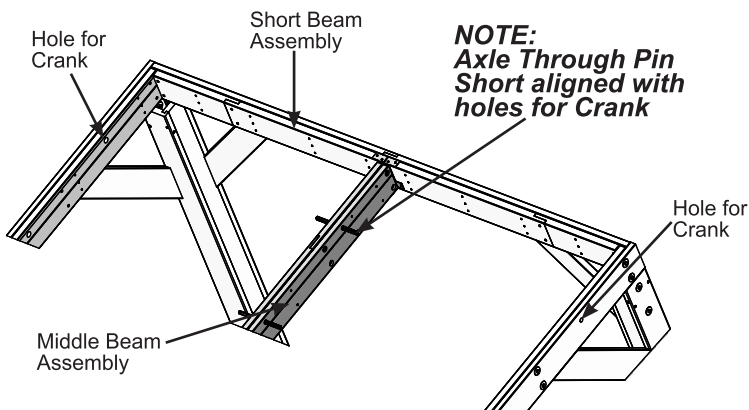

## Hardware

24 x #8 x 1-1/2" Wood Screw

# Step 11: Attach Middle Beam Assembly Part 2

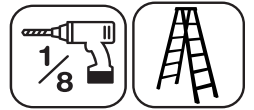

**C:** Predrill with a 1/8" drill bit then attach Short Beam Assemblies to Middle Beam Assemblies with four #10 x 4" Wood Screws per end. (F11.6)

**F11.6**  
*Outside View*

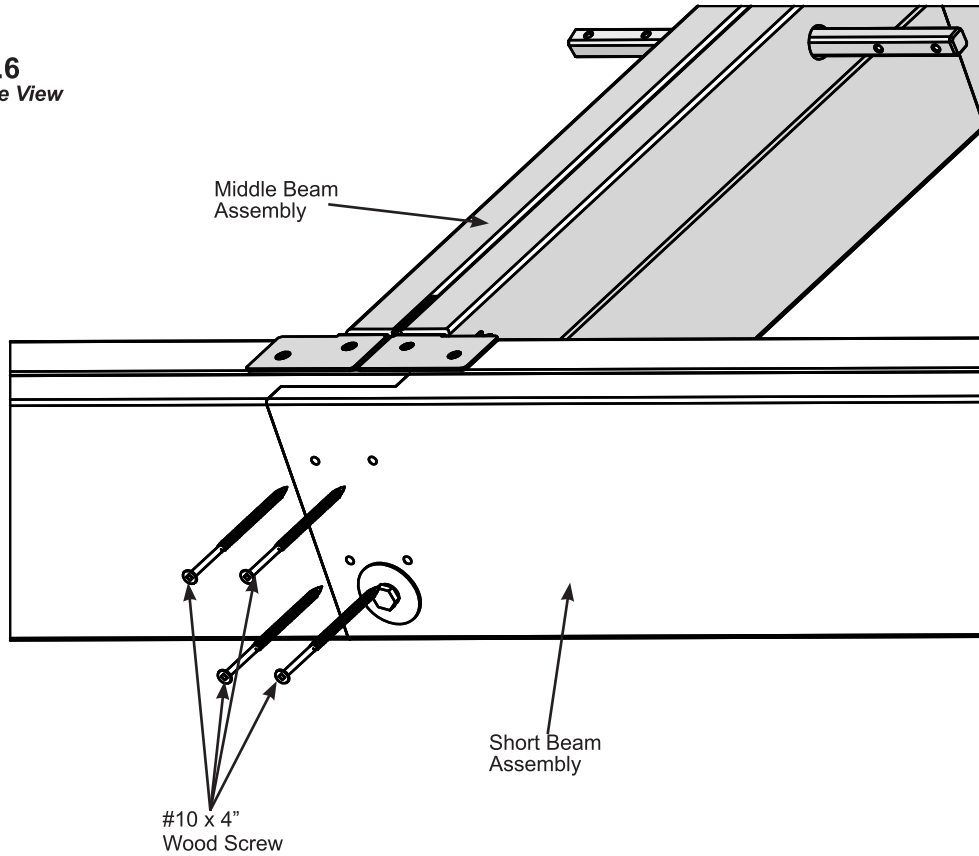

### Hardware

8 x #10 x 4" Wood Screw



# Step 12: Attach Post Blocks



**A:** At each Mid Post Assembly place two (1354) Post Blocks, one on each side of the Center Beam Assemblies tight to the Long Beam Assembly and Center Beam Assembly. Attach each (1354) Post Block to Mid Post with one #8 x 2-1/4" Wood Screw per block. (F12.1 and F12.2)

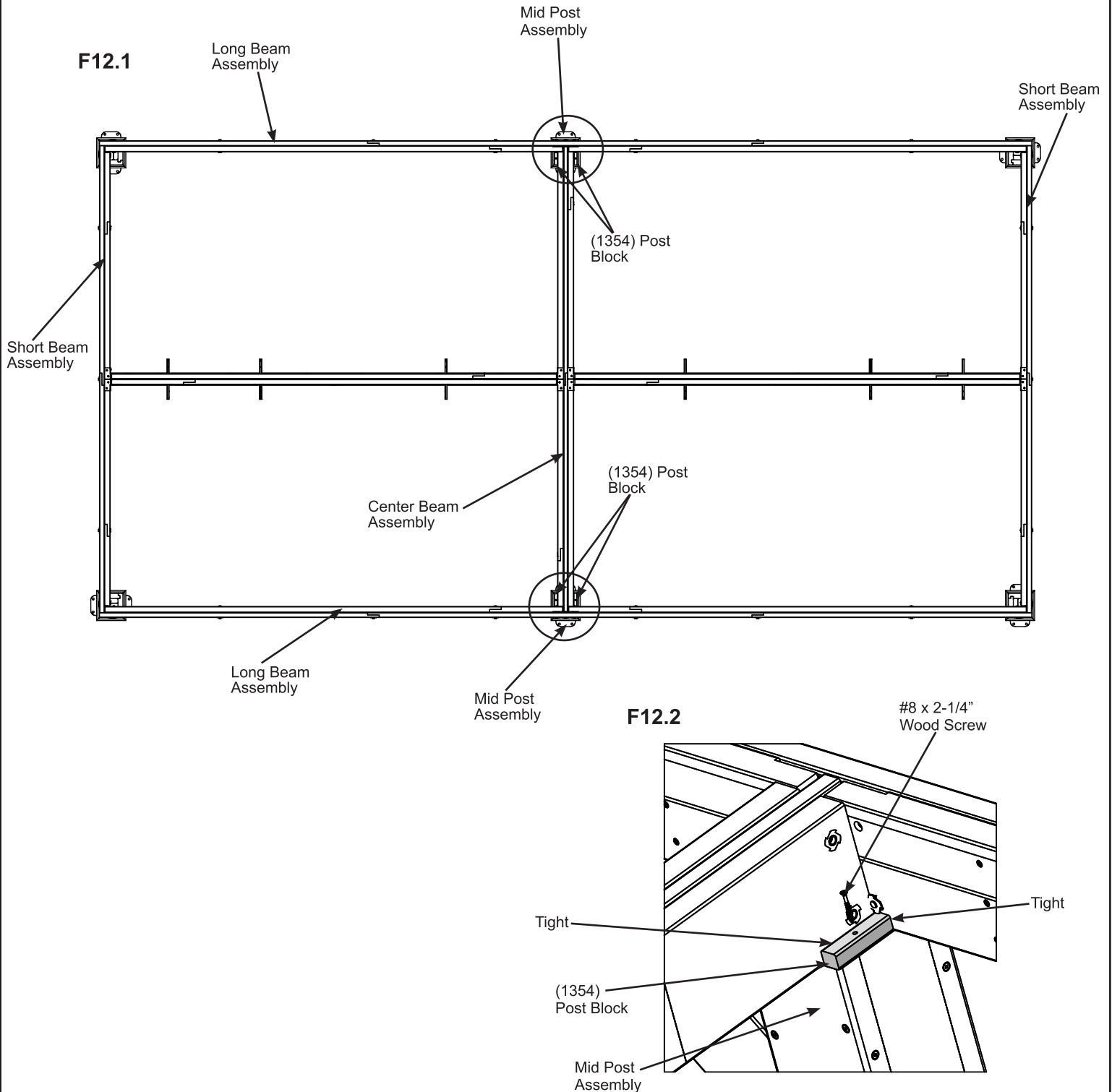

### Wood Parts

4 x (1354) Post Block

### Hardware

4 x #8 x 2-1/4" Wood Screw

# Step 13: Attach Louvered Rails Part 1



**A:** On the inside of each end of both Long Beam Assemblies, in the groove, place one Louver Rail Assembly 2378.3. Make sure the rail is oriented so the third bushing (with arrow on top) is lined up with the hole for the Crank. Attach to Long Beam Assembly with eight #8 x 1" Pan Screws per Louver Rail Assembly. (F13.1 and F13.2)

**B:** Tight to each Louver Rail Assembly 2378.3 place one Louver Rail Assembly 523 then attach with two #8 x 1" Pan Screws. (F13.1 and F13.2)

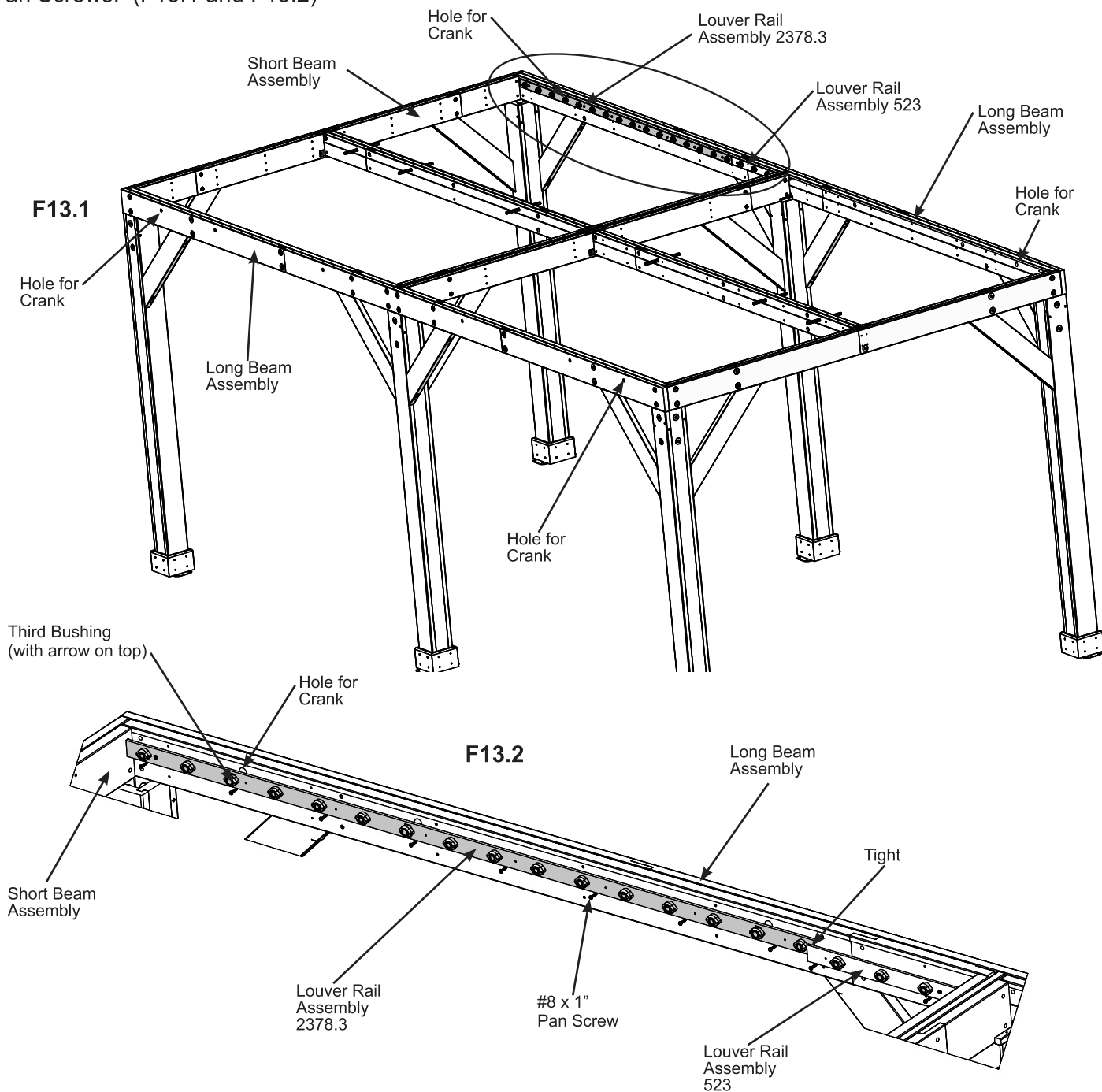

### Components

4 x Louver Rail Assembly 2378.3  
4 x Louver Rail Assembly 523

### Hardware

40 x #8 x 1" Pan Screw

# Step 13: Attach Louvered Rails Part 2



**C:** On each side of both Middle Beam Assemblies, in the groove, place one Louver Rail Assembly 2378.3. Make sure the rail is oriented so the three bushings (with arrow on top) are inserted over the three Axle Through Pin Shorts. Attach to Middle Beam Assemblies with eight #8 x 1" Pan Screws per Louver Rail Assembly. (F13.3 and F13.4)

**B:** Tight to each Louver Rail Assembly 2378.3 place one Louver Rail Assembly 523 then attach with two #8 x 1" Pan Screws. (F13.3 and F13.4)

**F13.3**

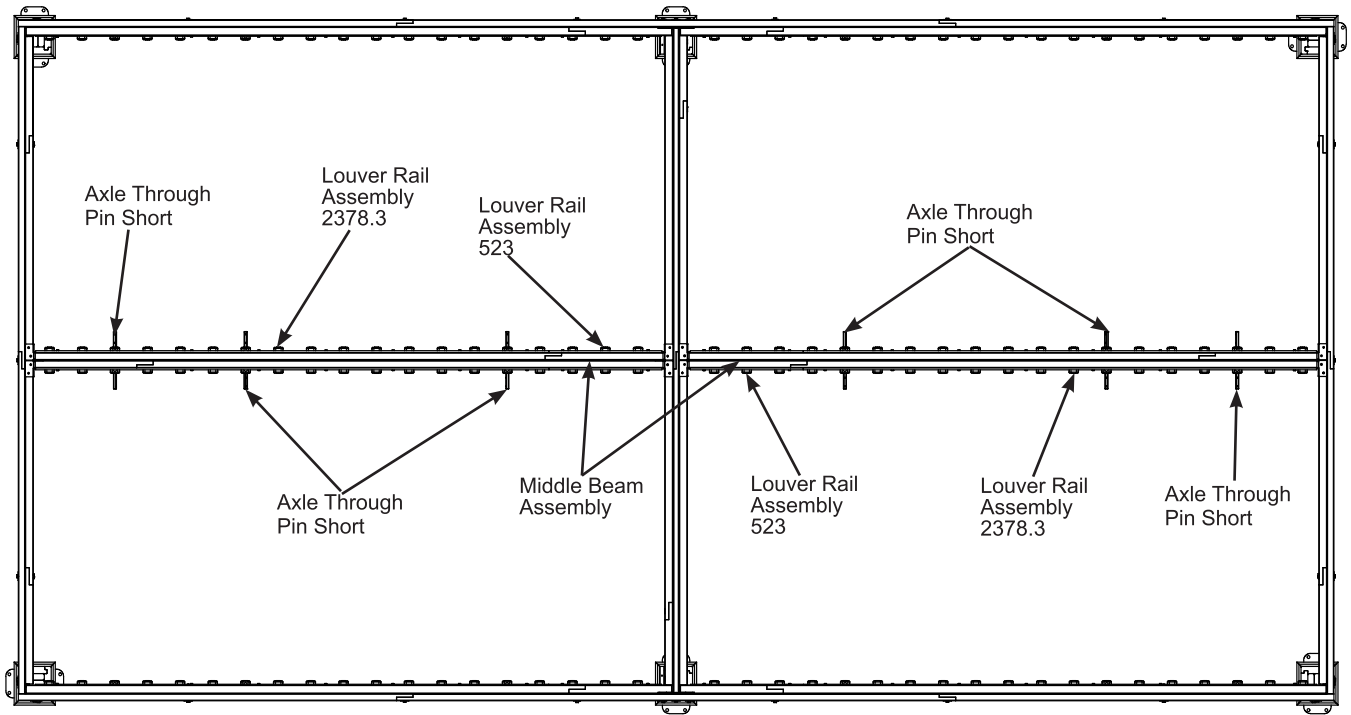

**F13.4**

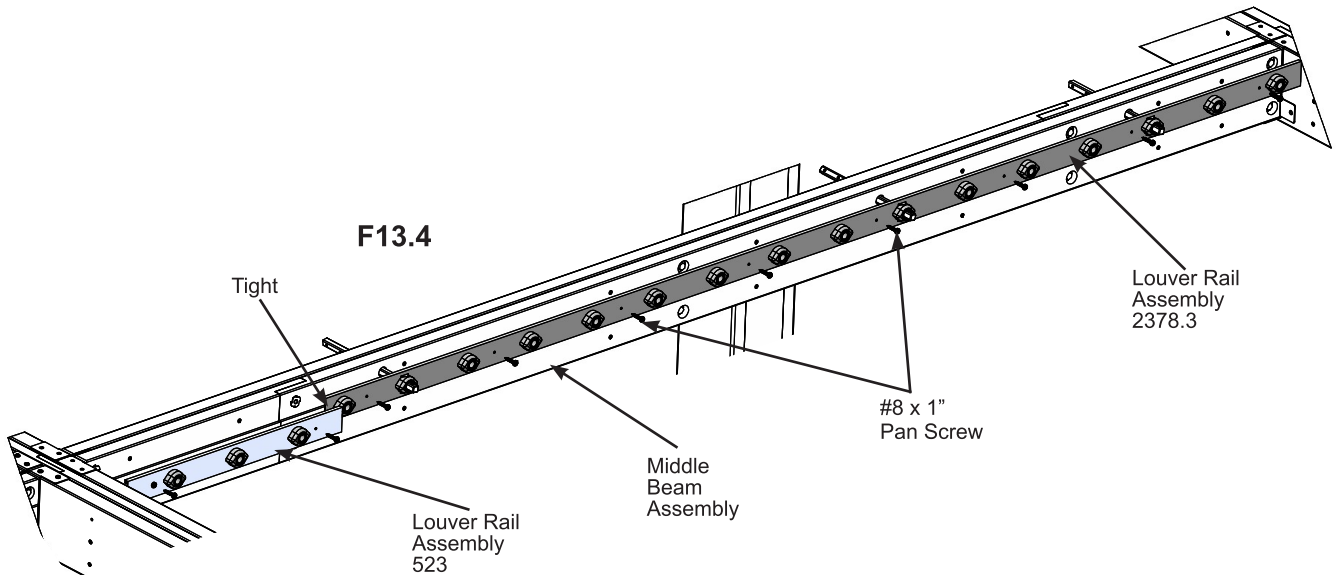

**Components**

- 4 x Louver Rail Assembly 2378.3
- 4 x Louver Rail Assembly 523

**Hardware**

- 40 x #8 x 1" Pan Screw

# Step 14: Attach Gutter Drain Corners

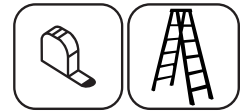

**A:** Measure approximately 1/2" (1.27 cm) in from both edges of each Gutter Drain Corner then apply a small bead of sealant, as shown in F14.1 and F14.2.

**B:** On each Post Assembly place one Gutter Drain Corner so it is tight to the Long and Short Beam Assemblies. Do not attach at this step. (F14.3 and F14.4)

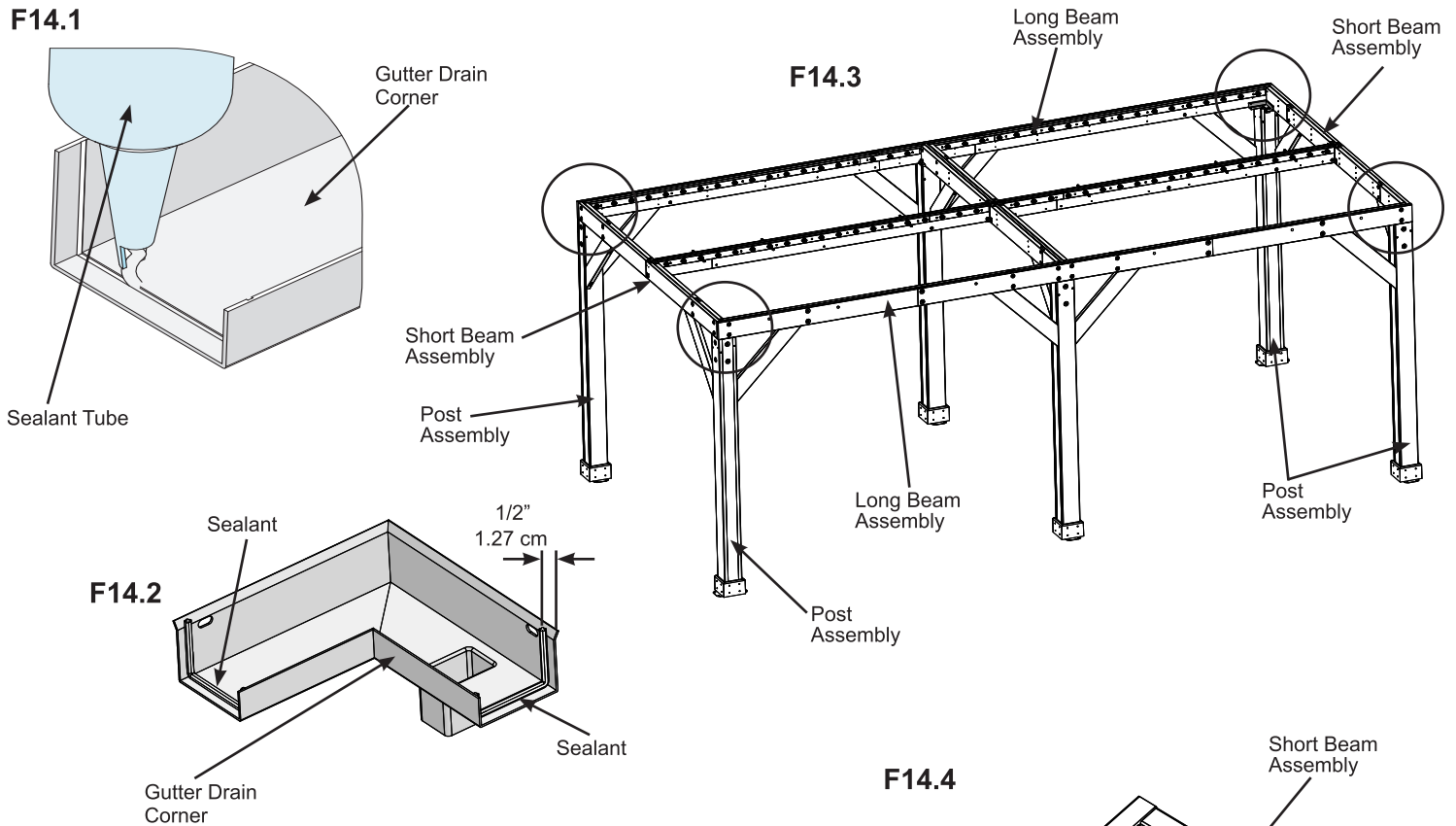

**Note:** All surfaces to be clean, dry, dust and grease free before application with temperatures above 5°C (41°F), no warmer than 35°C (95°F).

- Remove cap and cut a small piece off the nozzle for a small bead.
- Apply sealant in small beads and smooth as required.
- Clean excess with a cloth or paper towel before it skins over.
- Always wear safety glasses and rubber gloves when using product.

**See page 6 for Warning and First Aid Information.**

## Components

4 x Gutter Drain Corner  
Sealant

# Step 15: Rain Gutter Assembly

## Part 1

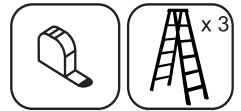

**A:** Measure approximately 1/2" (12.7 mm) in from both edges of twelve Gutter Corners and eight Gutter Connectors then apply a small bead of sealant, as shown in F15.1, F15.2 and F15.3.

**B:** Place Gutter Corner tight to Short Beam Assembly and Mid Beam Assembly, flush to the bottom of Mid Beam Assembly. Have a helper hold it in place. (F15.4 and 15.6)

**C:** Slide one Rain Gutter G into Gutter Drain Corner and Gutter Corner along the Short Beam Assembly. Attach, Rain Gutter to Short Beam Assembly with five #8 x 1" Pan Screws. (F15.4, F15.5 and 15.6)

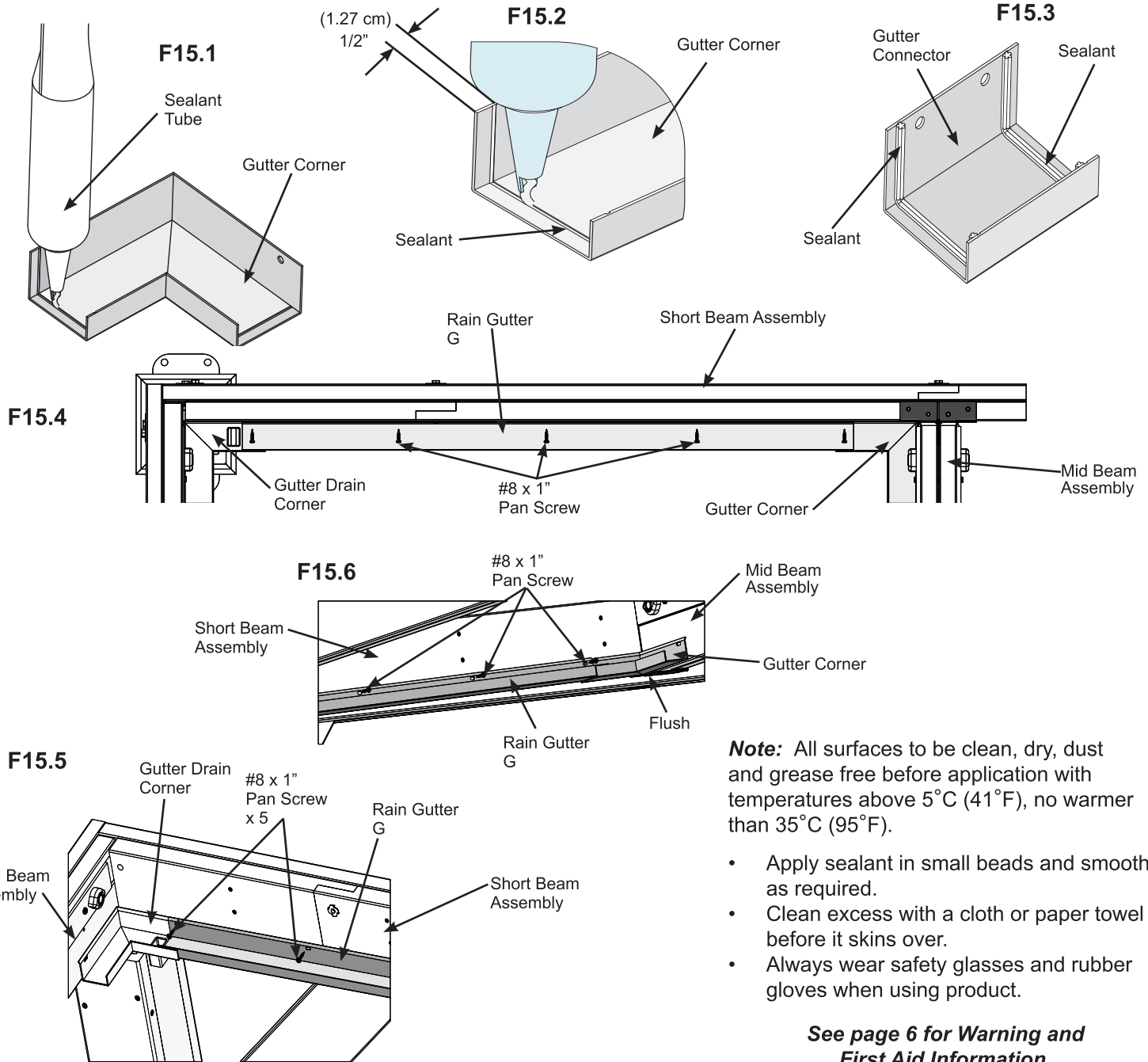

### Components

12 x Gutter Corner  
8 x Gutter Connector  
4 x Rain Gutter G  
Sealant

### Hardware

20 x #8 x 1" Pan Screw

# Step 15: Rain Gutter Assembly

## Part 2



**D:** Place Gutter Corner on one (1354) Post Block tight to the Long Beam and Center Beam Assemblies. (F15.7)

**E:** Slide one Rain Gutter H into Gutter Corner along the Long Beam Assembly then place one Gutter Connector at the end of Rain Gutter H. Gutter Connector to sit 3/8" (0.95 cm) up from bottom of beam. (F15.7, F15.8 and F15.9)

**F:** Slide one Rain Gutter H into Gutter Drain Corner along the Long Beam Assembly and into Gutter Connector. (F15.7, F15.8 and F15.9).

**G:** Attach, Rain Gutters to Long Beam Assembly with (10) #8 x 1" Pan Screws. (F15.7, F15.8 and F15.9)

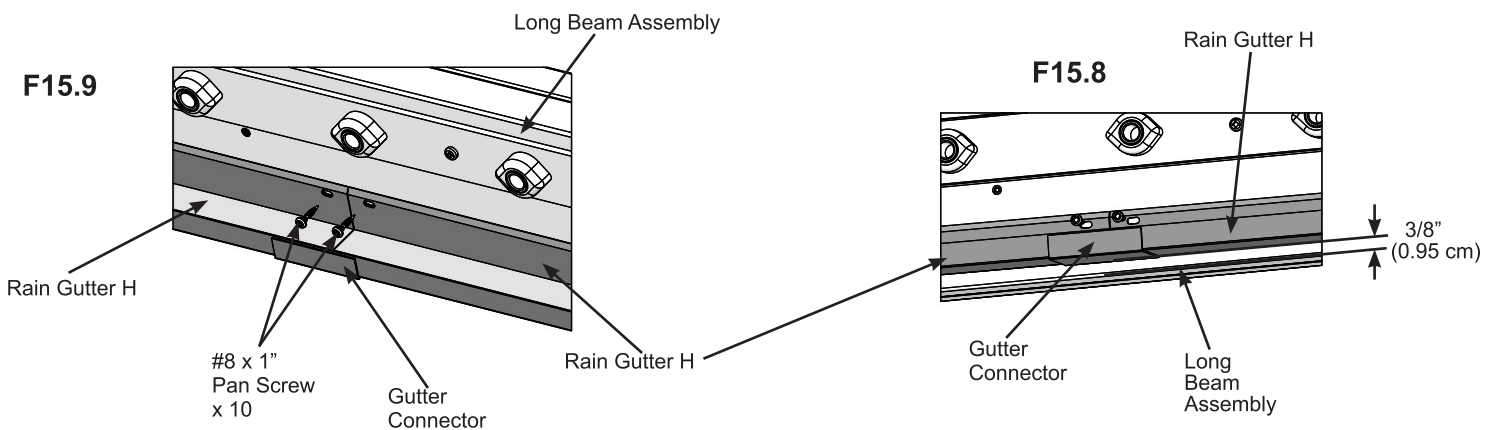
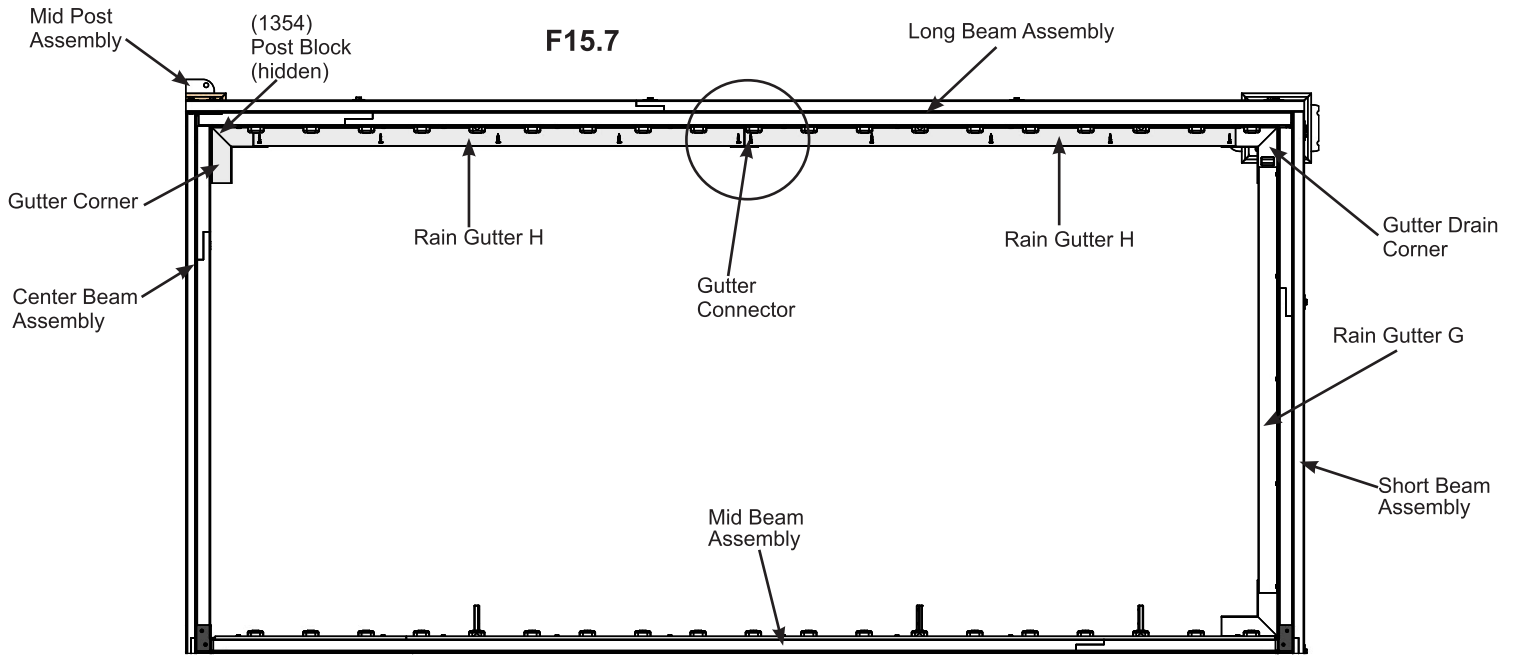

### Components

8 x Rain Gutter H

### Hardware

40 x #8 x 1" Pan Screw

# Step 15: Rain Gutter Assembly Part 3



**H:** Place Gutter Corner tight to Center Beam Assembly and Mid Beam Assembly, 3/4" (1.91 cm) up from the bottom of Mid Beam Assembly. Have one helper hold it in place. (F15.10 and F15.11)

**I:** Slide Rain Gutter G into each Gutter Corner along the Center Beam Assembly. Attach, Rain Gutters to Center Beam Assembly with five #8 x 1" Pan Screws. (F15.10 and F15.12)

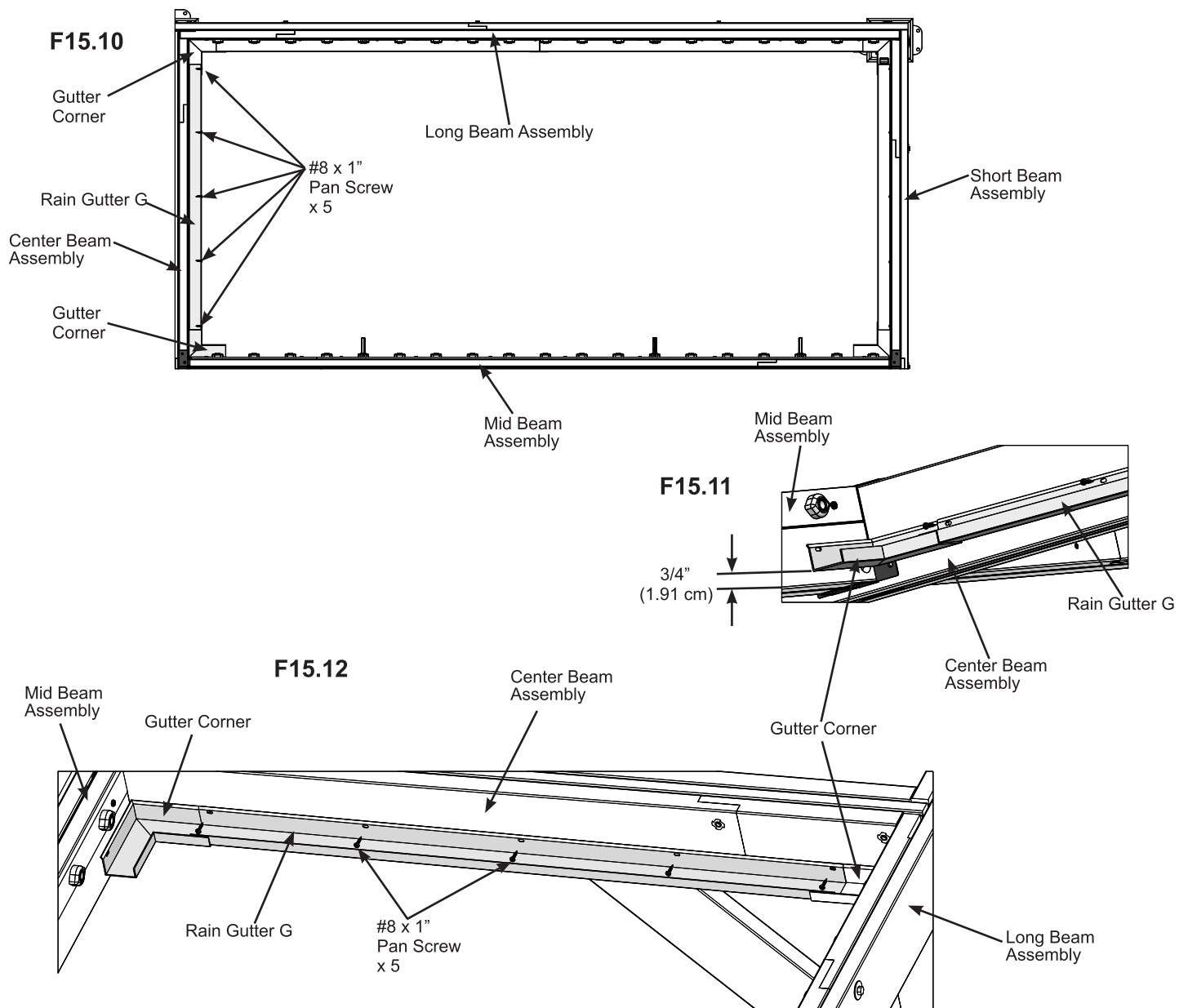

### Components

4 x Rain Gutter G

### Hardware

20 x #8 x 1" Pan Screw

# Step 15: Rain Gutter Assembly

## Part 4



**J:** Slide one Rain Gutter H into each Gutter Corner along the Mid Beam Assembly with a Gutter Connector in the middle as done for the Long Beam Assembly. Gutter Connector to sit 3/8" (0.95 cm) up from the bottom of the Mid Beam Assembly. (F15.13 and F15.14)

**K:** Attach, Rain Gutter to Mid Beam Assembly with (10) #8 x 1" Pan Screws. (F15.13 and F15.15)

**F15.13**

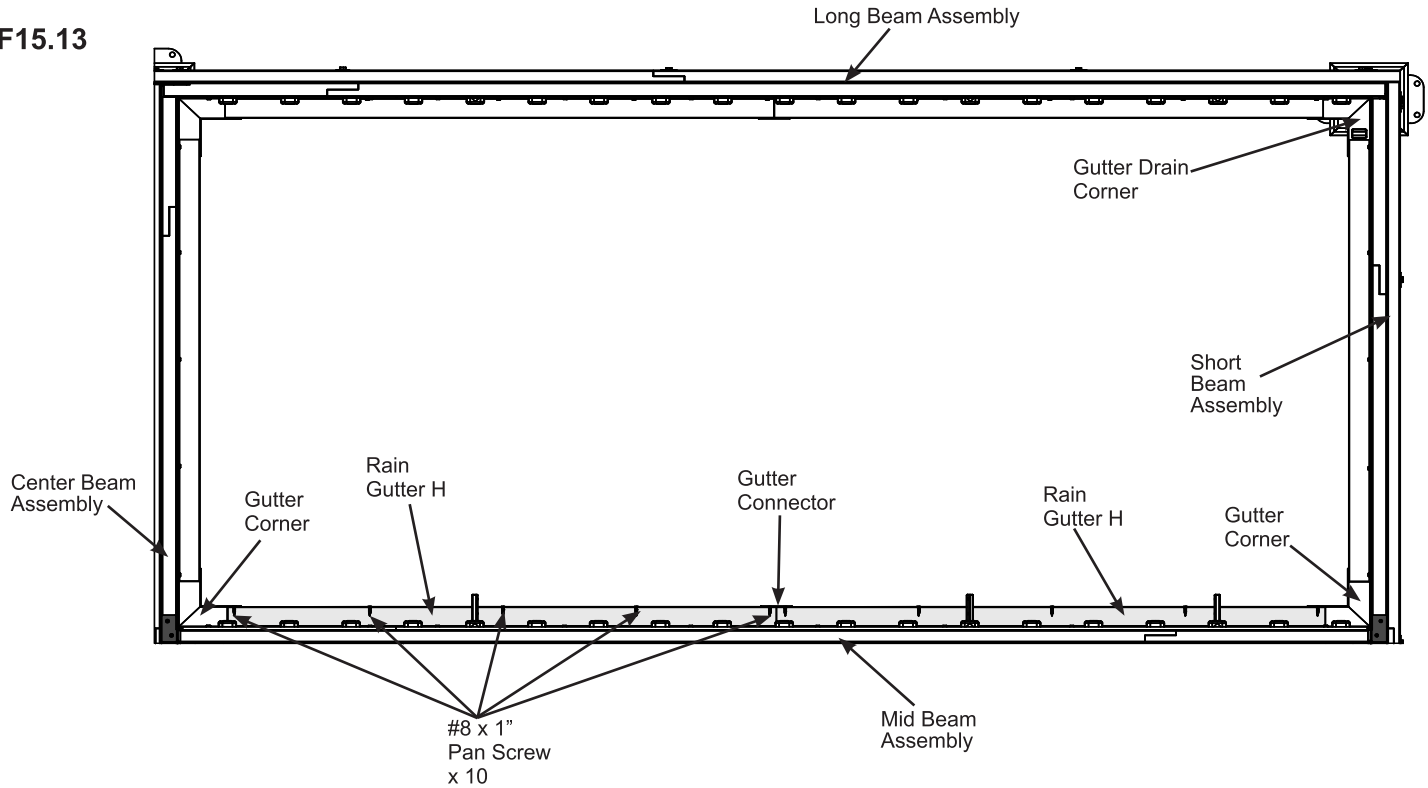

**F15.15**

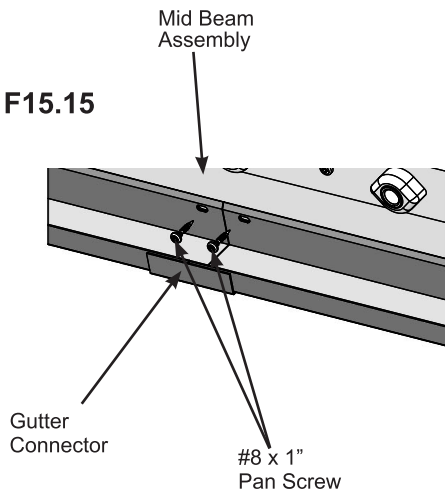

**F15.14**

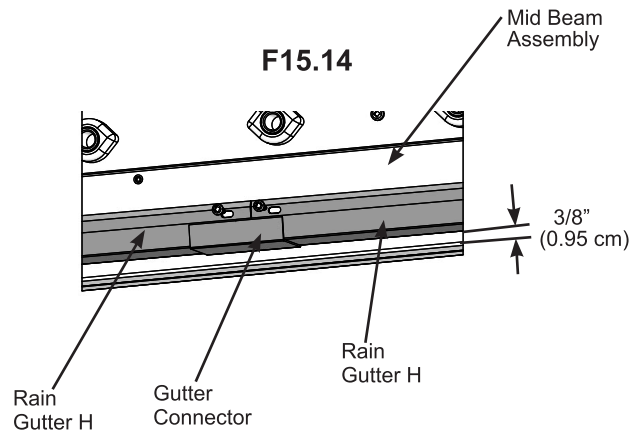

**Components**

8 x Rain Gutter H

**Hardware**

40 x #8 x 1" Pan Screw



# Step 16: Apply Sealant Part 1



**A:** At each end of Rain Gutter G and Rain Gutter H apply a small, evenly distributed bead of sealant over the connector joints. Smooth sealant into the joint so it forms a continuous, water-tight seal. (F16.1, F16.2 and F16.3)

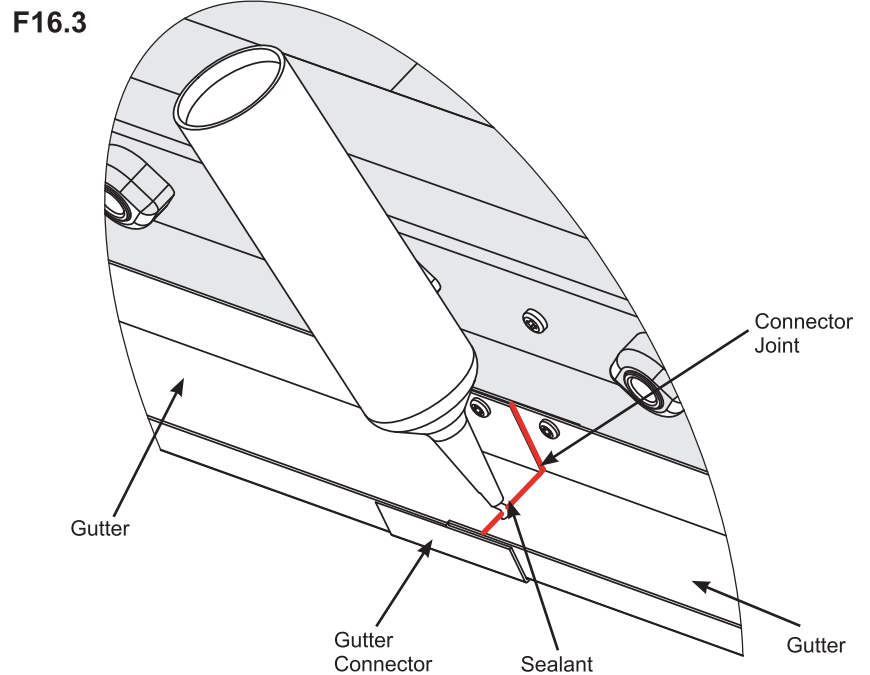
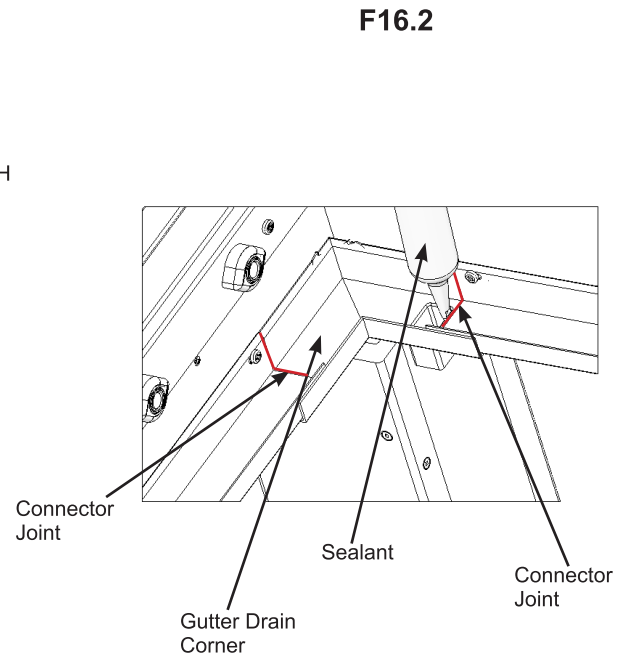
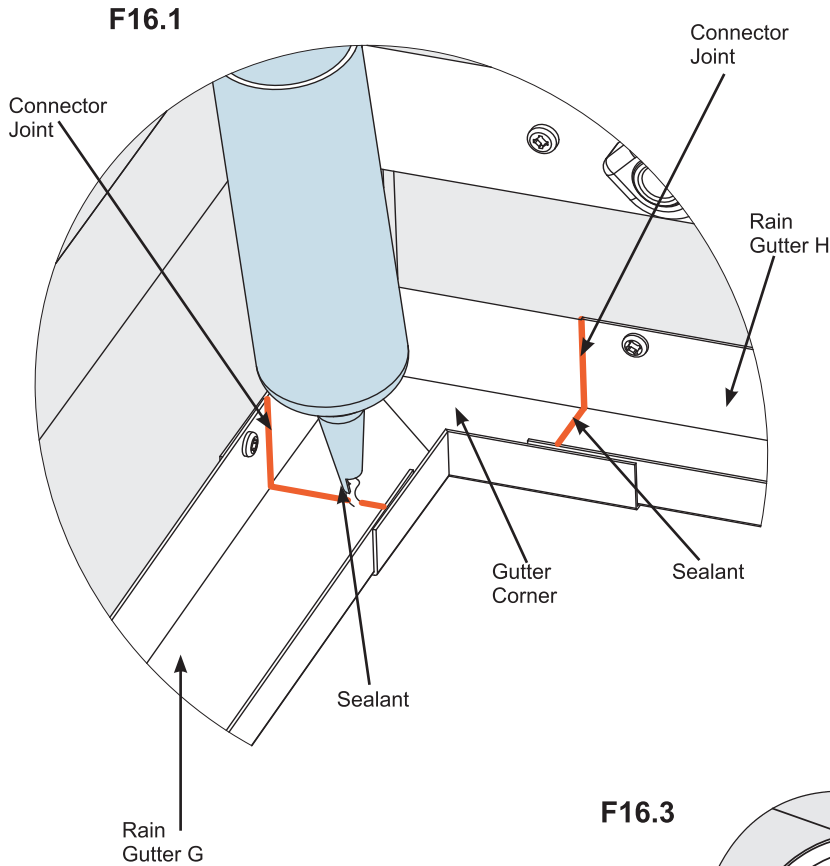

**Note:** All surfaces to be clean, dry, dust and grease free before application with temperatures above 5°C (41°F), no warmer than 35°C (95°F).

- Apply sealant in small beads and smooth as required.
- Clean excess with a cloth or paper towel before it skins over.
- Always wear safety glasses and rubber gloves when using product.

**See page 6 for Warning and First Aid Information.**

## Components

Sealant

# Step 16: Apply Sealant Part 2



**B:** In the seams of the Mid Beam Assembly and Center Beam Assembly apply a small evenly distributed bead of sealant and smooth out so it forms a continuous, water-tight seal. (F16.4)

**C:** Along the tops of the Rain Gutters on both Short Beam Assemblies, both Long Beam Assemblies and each side of the Middle Beam and Center Beam, including the tops of the Gutter Corners and Gutter Drain Corners, apply a small evenly distributed bead of sealant, smoothing the sealant so it gets into the joints. (F16.5)

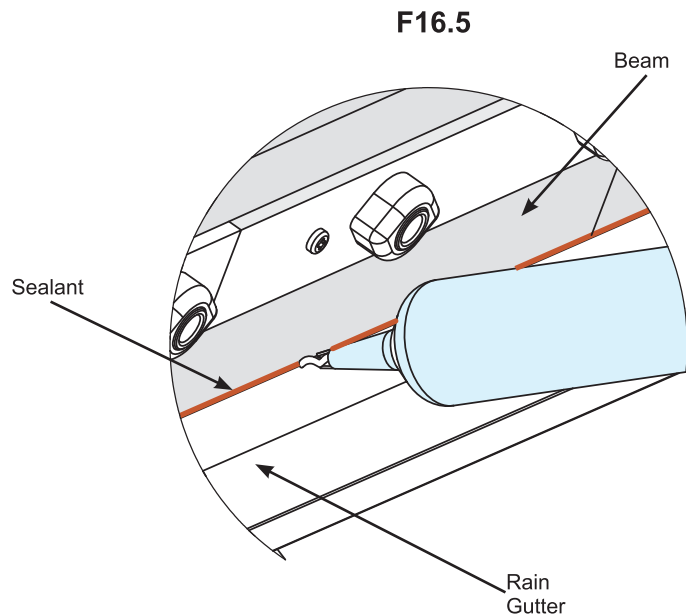
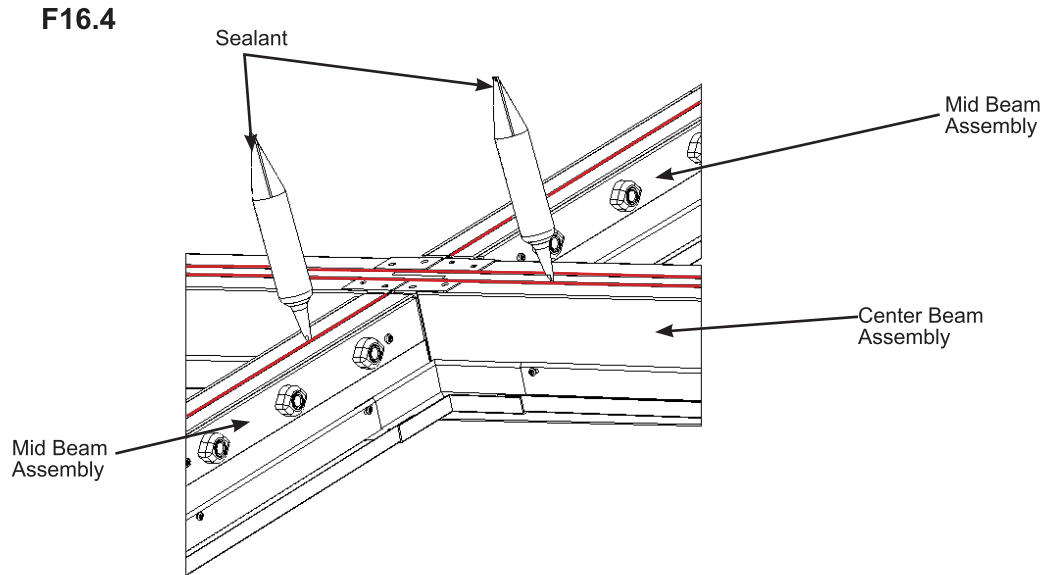

**Note:** All surfaces to be clean, dry, dust and grease free before application with temperatures above 5°C (41°F), no warmer than 35°C (95°F).

- Apply sealant in small beads and smooth as required.
- Clean excess with a cloth or paper towel before it skins over.
- Always wear safety glasses and rubber gloves when using product.

**See page 6 for Warning and First Aid Information.**

## Components

Sealant

# Step 17: Attach Downspout Part 1



**A:** On the post with Gutter Drain Corner slide Downspout 1935 onto the Gutter Drain Corner. (F17.1 and F17.2)

**B:** Attach the Downspout Bottom Elbow to the bottom of Downspout 1935 then attach Downspout 165 to Downspout Bottom Elbow. (F17.1 and F17.3)

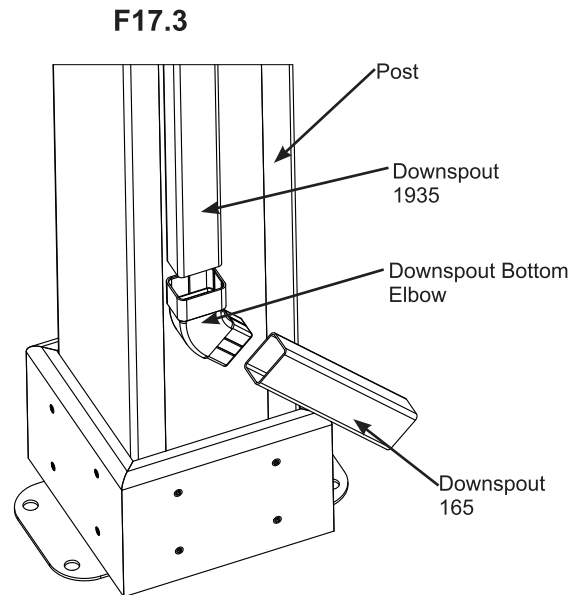
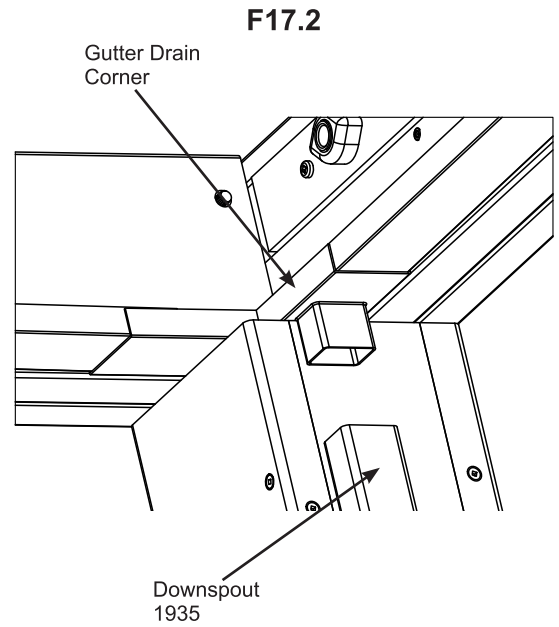
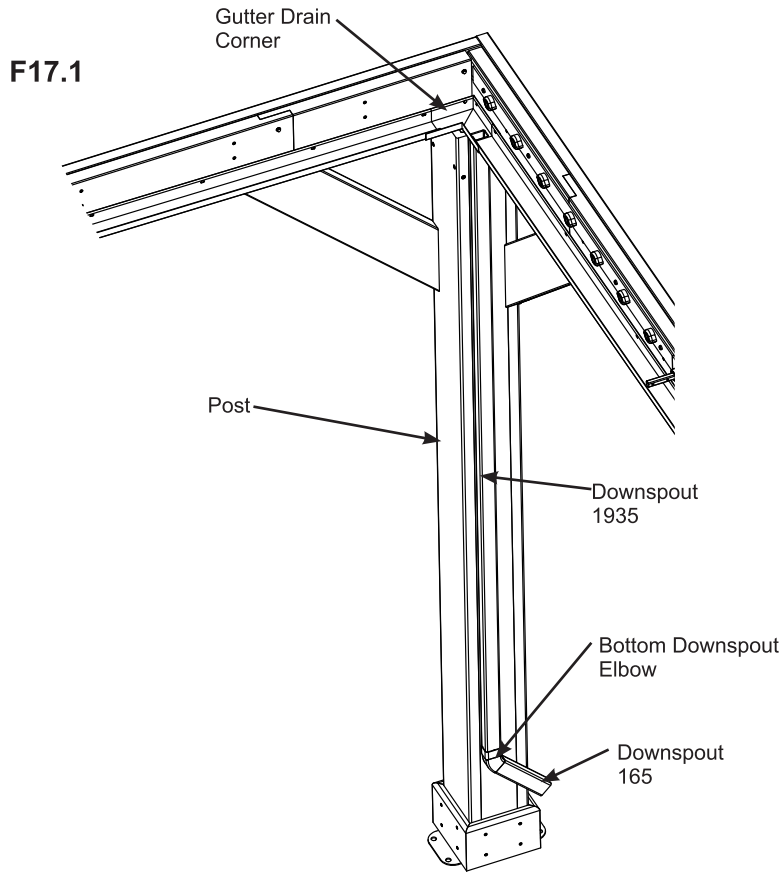

## Components

- 4 x Downspout 1935
- 4 x Downspout Bottom Elbow
- 4 x Downspout 165

# Step 17: Attach Downspout Part 2



**C:** Make sure Downspout 1935 is tight to bottom of Gutter Drain Corner. Attach Downspout Straps to the top, middle and bottom of Downspout 1935 with two #8 x 1 Pan Screws per strap. (F17.4 and F17.5)

**D:** Repeats Steps A - C on the other three Gutter Corner Drains.

**F17.4**

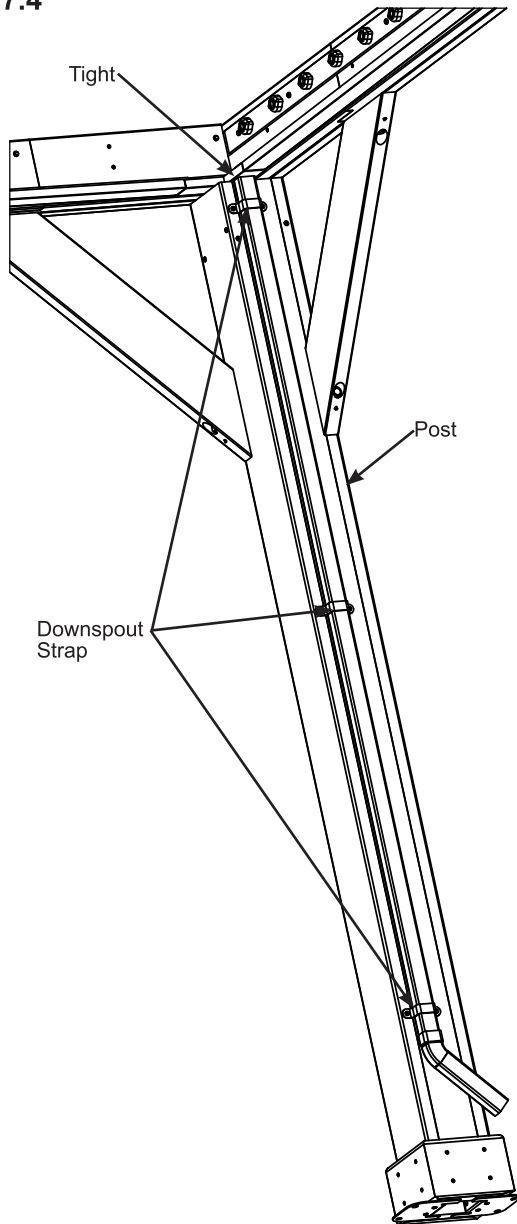

**F17.5**

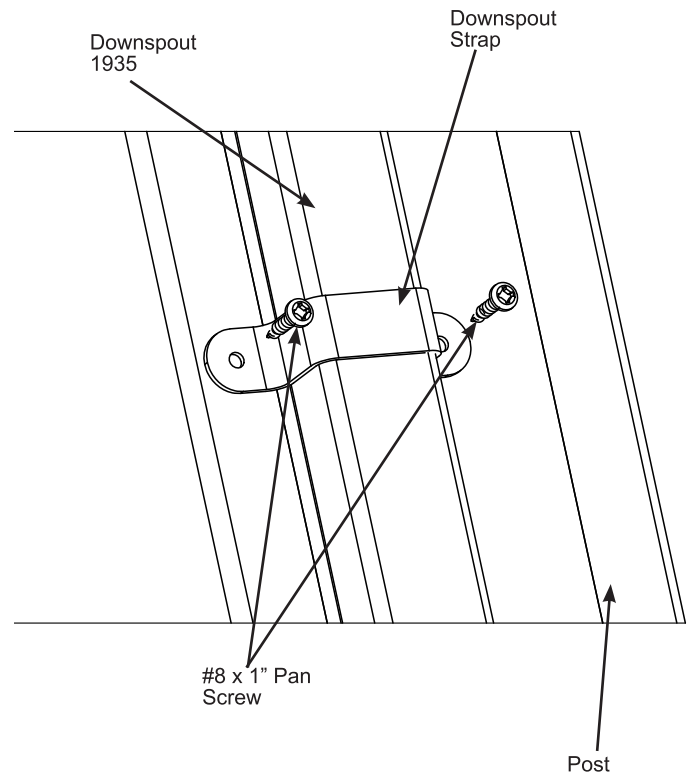

**Components**  
12 x Downspout Strap

**Hardware**  
24 x #8 x 1" Pan Screw

# Step 18: Louver Assemblies Part 1

**A:** On 12 Louvers attach one Louver End Plate to each end with two #8 x 1" Pan Screws per plate. Use a Standard Pin to help line up proper placement. Remove Standard Pin when Louver End Plate is secure. (F18.1, F18.2 and F18.3)

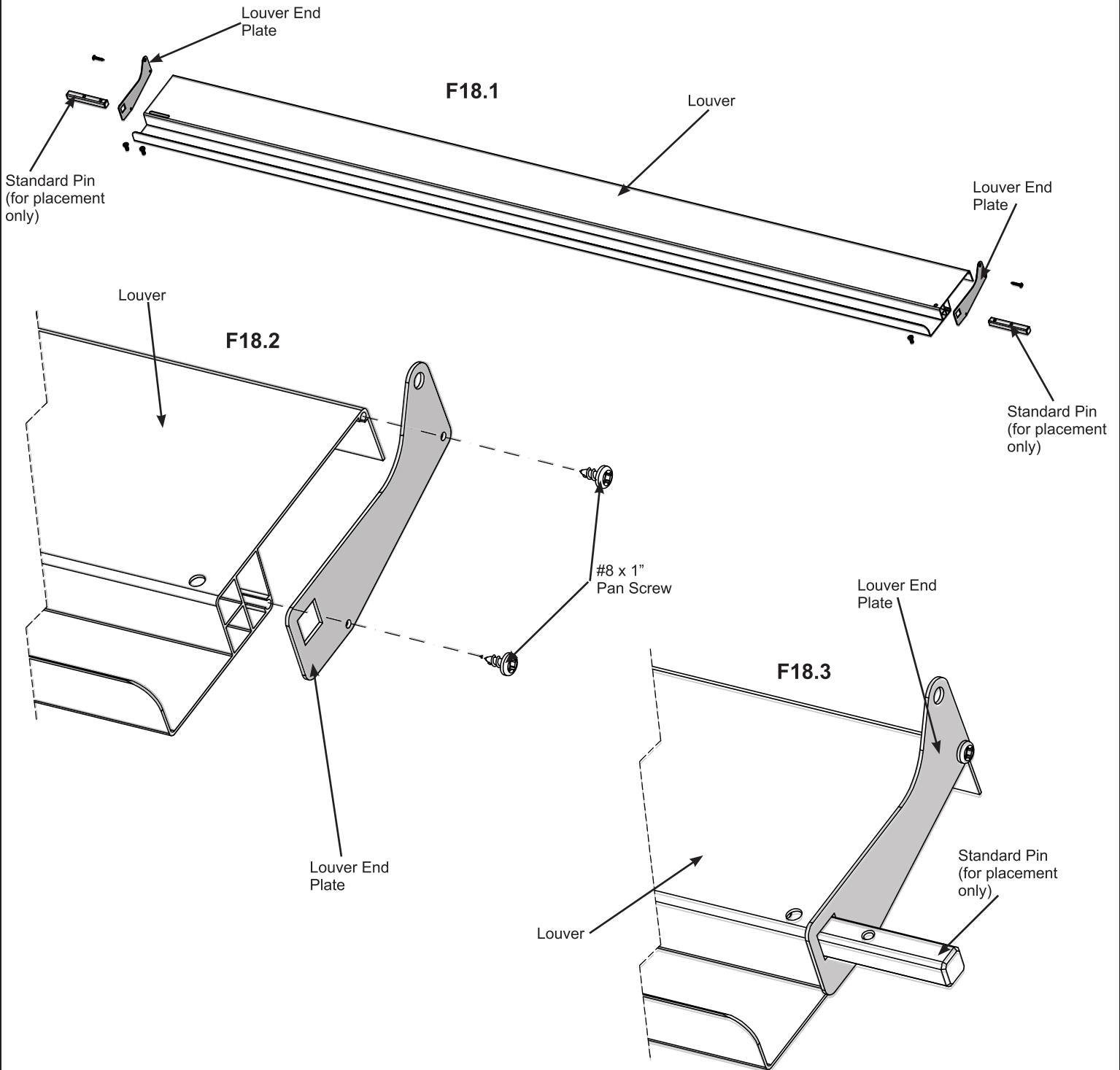

### Components

12 x Louver  
24 x Louver End Plate

### Hardware

48 x #8 x 1" Pan Screw

# Step 18: Louver Assemblies Part 2

**B:** On the remaining 64 Louvers place one Standard Pin in the square slot at each end. Push pins all the way in to the second bolt hole. On the side of the Louver with the single bolt hole, tightly attach to pin with one 1/4 x 1/2" Pan Bolt. On the side of the Louver with the bolt slot, loosely attach to pin with one 1/4 x 1/2" Pan Bolt. Notice which end of Standard Pin is inserted in Louvers. (F18.4, F18.5 and F18.6)

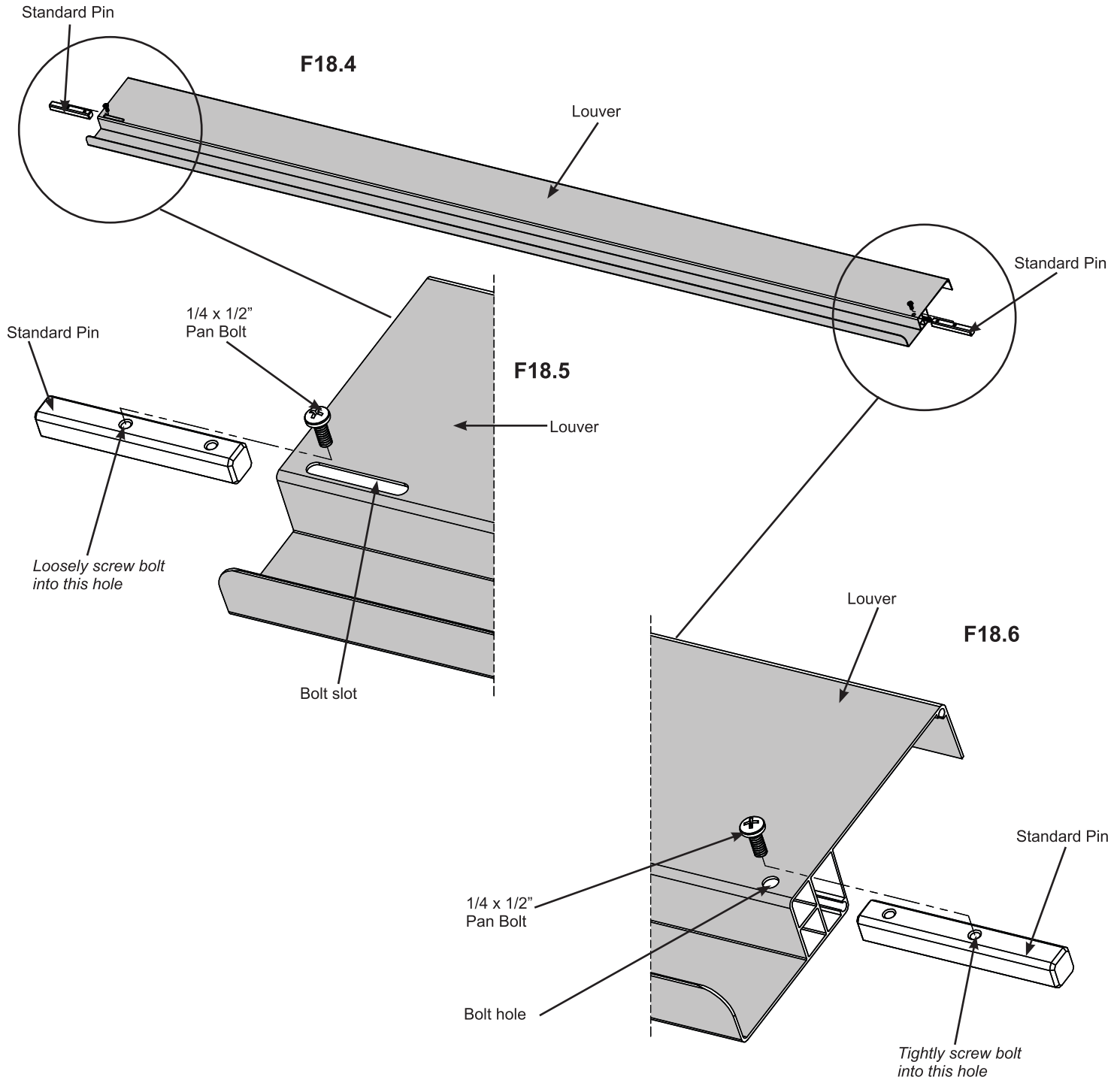

### Components

64 x Louver  
128 x Standard Pin

### Hardware

128 x 1/4 x 1/2" Pan Bolt

# Step 18: Louver Assemblies

## Part 3

**C:** Place one Louver End Plate at each end of the Louvers, fitting over the pins then attach with two #8 x 1" Pan Screws per plate. (F18.7 and F18.8)

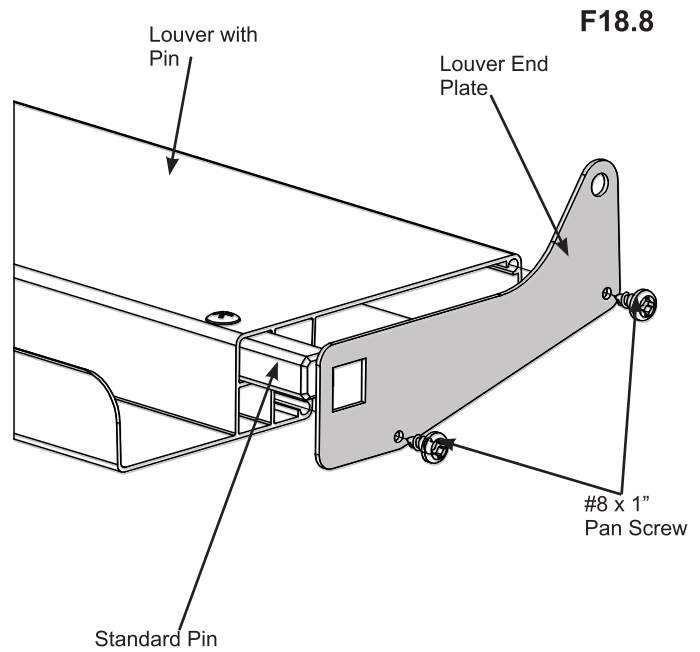
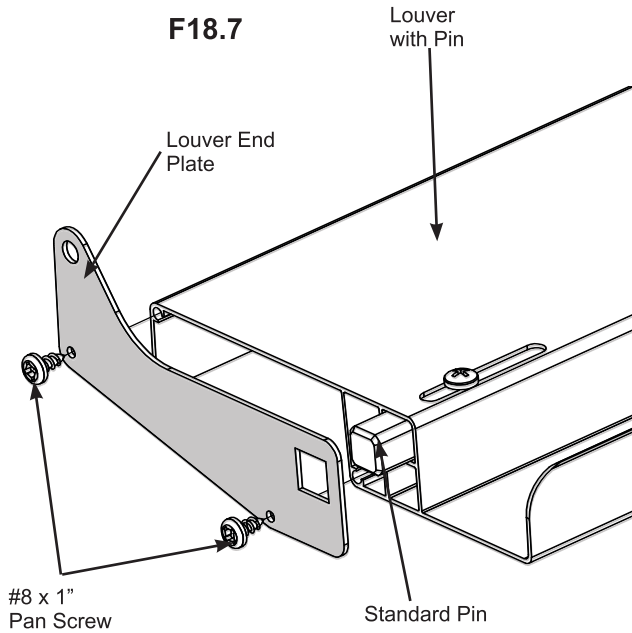

### Components

128 x Louver End Plate

### Hardware

256 x #8 x 1" Pan Screw

# Step 18: Louver Assemblies

## Part 4

D: On each Louver End Plate loosely attach one 1/4 x 5/8" Pan Bolt (with nylon washer and 1/4" lock nut) per plate. (F18.9 and F18.10)

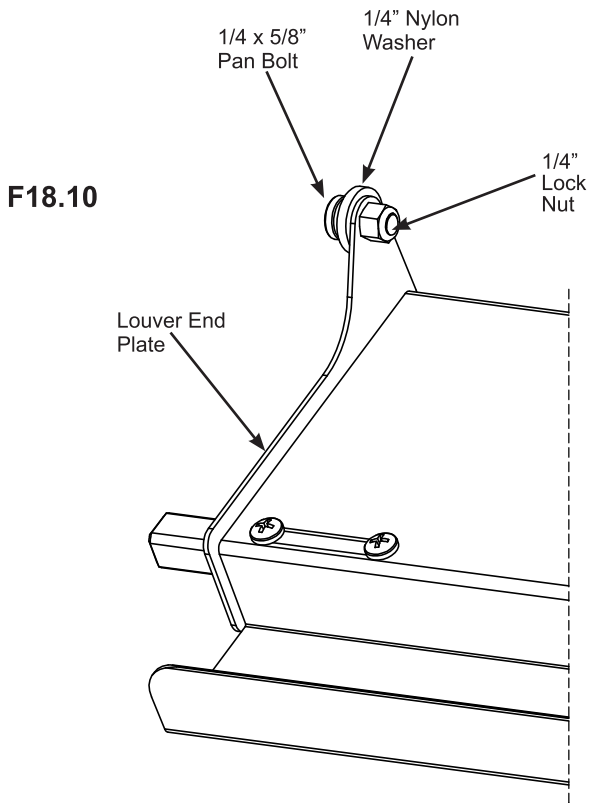
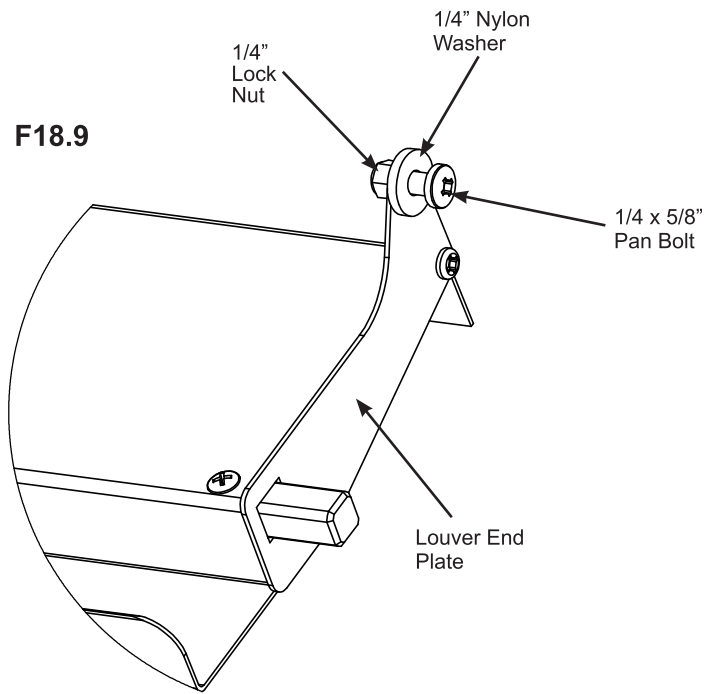

### Hardware

152 x 1/4 x 5/8" Pan Bolt  
(1/4" nylon washer, 1/4" lock nut)



# Step 19: Attach Louver Assemblies Part 1



**A:** Starting at the Crank End Side, with one Louver with pins, bolt at the top. Move the pin in the bolt slot end all the way into the Louver. Insert fully tightened pin at bolt hole end into first bushing on the Long Beam Assembly. (F19.1, F19.2 and F19.3)

**B:** Slide the pin on the bolt slot end out of the Louver and into the first bushing on the Mid Beam Assembly and tighten bolt. Attach one 1/4 x 1/2" Pan Bolt into Standard Pin through bolt slot. Both bolts should be tight. (F19.1, F19.4 and F19.5)

**F19.1**

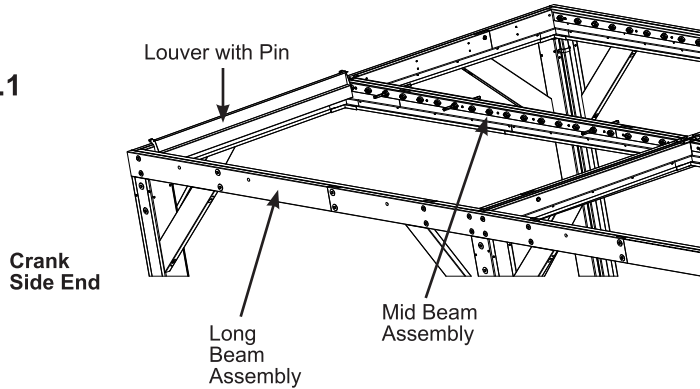

**F19.2**

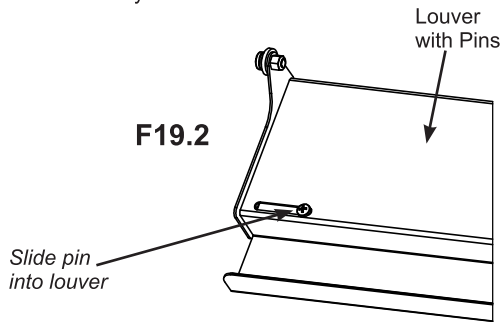

**F19.4**

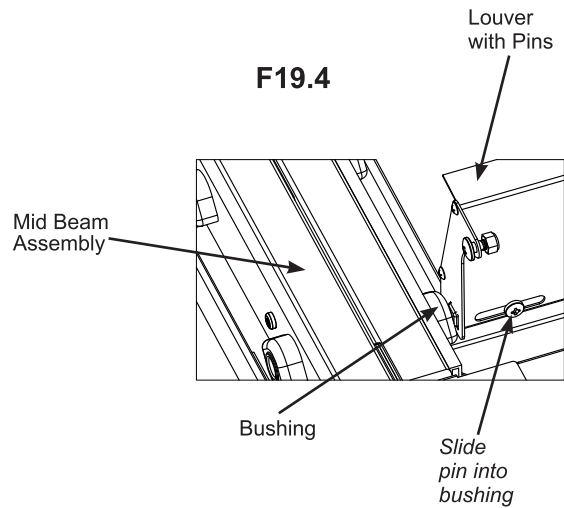

**F19.3**

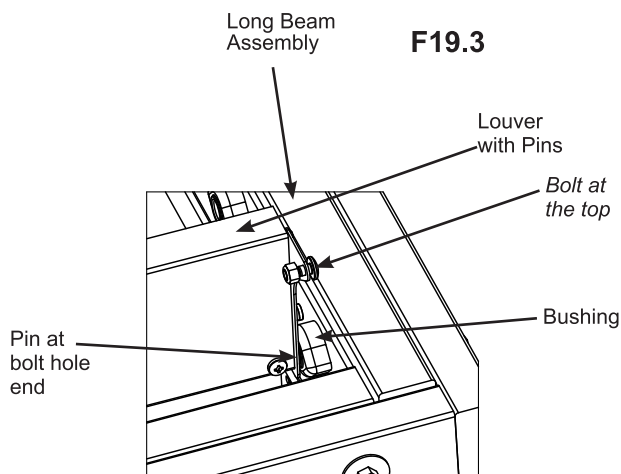

**F19.5**

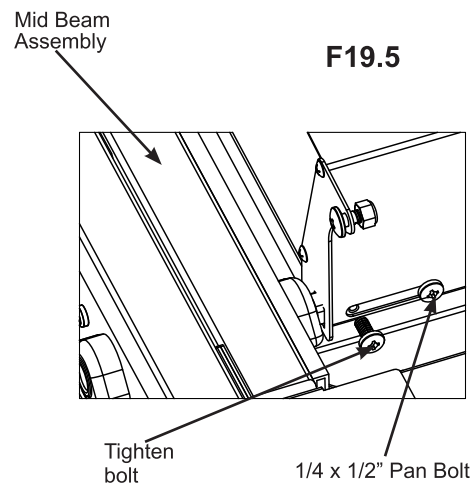

**Hardware**

4 x 1/4 x 1/2" Pan Bolt

# Step 19: Attach Louver Assemblies Part 2

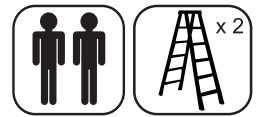

**C:** Repeat Steps A - B to install two Louvers with pins in the middle and last bushing (next to the Center Beam Assembly) (F19.6, F19.7, F19.8, F19.9 and F19.10)

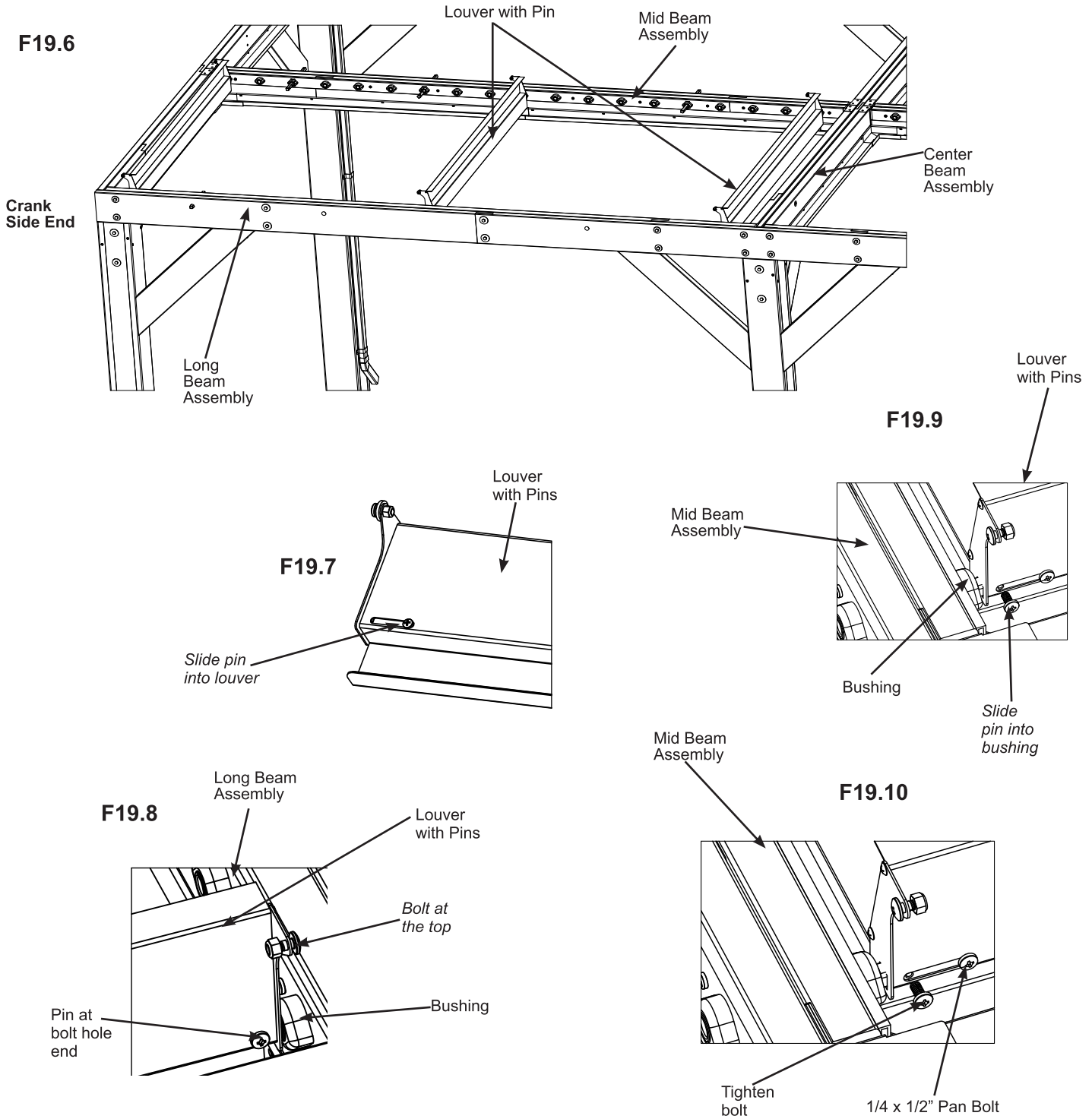

## Hardware

8 x 1/4 x 1/2" Pan Bolt

# Step 19: Attach Louver Assemblies Part 3

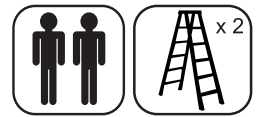

**D:** At the third bushing place one Louver without pins so the end with the bolt slot fits over the pin previously installed on the Mid Beam Assembly. Attach with two 1/4 x 1/2" Pan Bolts. (F19.11, F19.12 and F19.13)

**E:** Through the outside of the Long Beam Assembly insert one Drive Pin through the bushing with the arrow on top and into the Louver without pins. Attach with one 1/4 x 1/2" Pan Bolt into second hole of Drive Pin. (F19.11, F19.14 and F19.15)

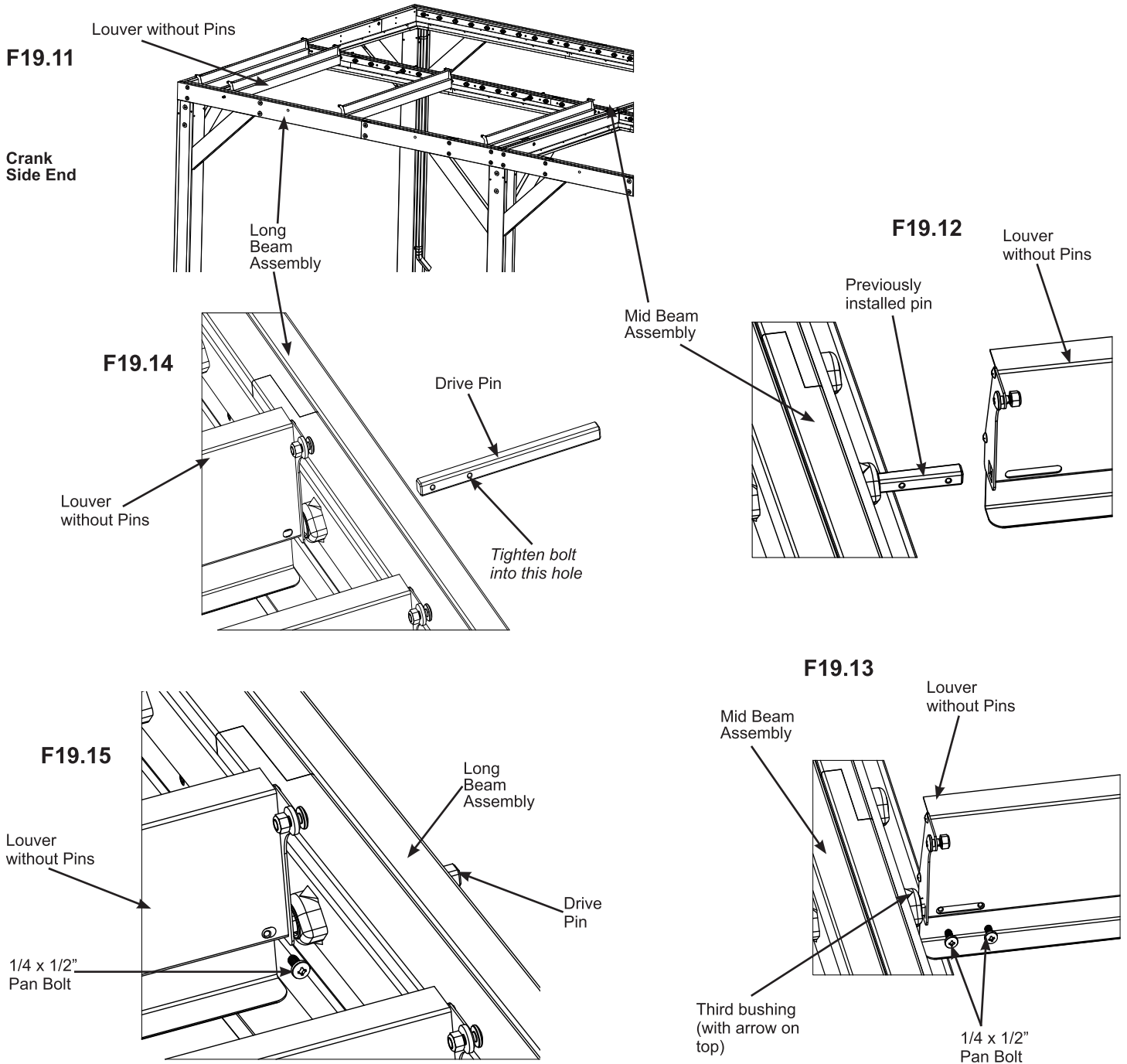

### Components

4 x Drive Pin

### Hardware

12 x 1/4 x 1/2" Pan Bolt

# Step 19: Attach Louver Assemblies Part 4

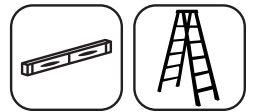

**E:** Place one Gear Box over the Drive Pin, make sure it is level then attach to Long Beam Assembly with two 1/4 x 1-15/16" Lag Screws (with 5/16" flat washer - gray) and two #8 x 3-1/2" Wood Screws. (F19.16 and F19.17)

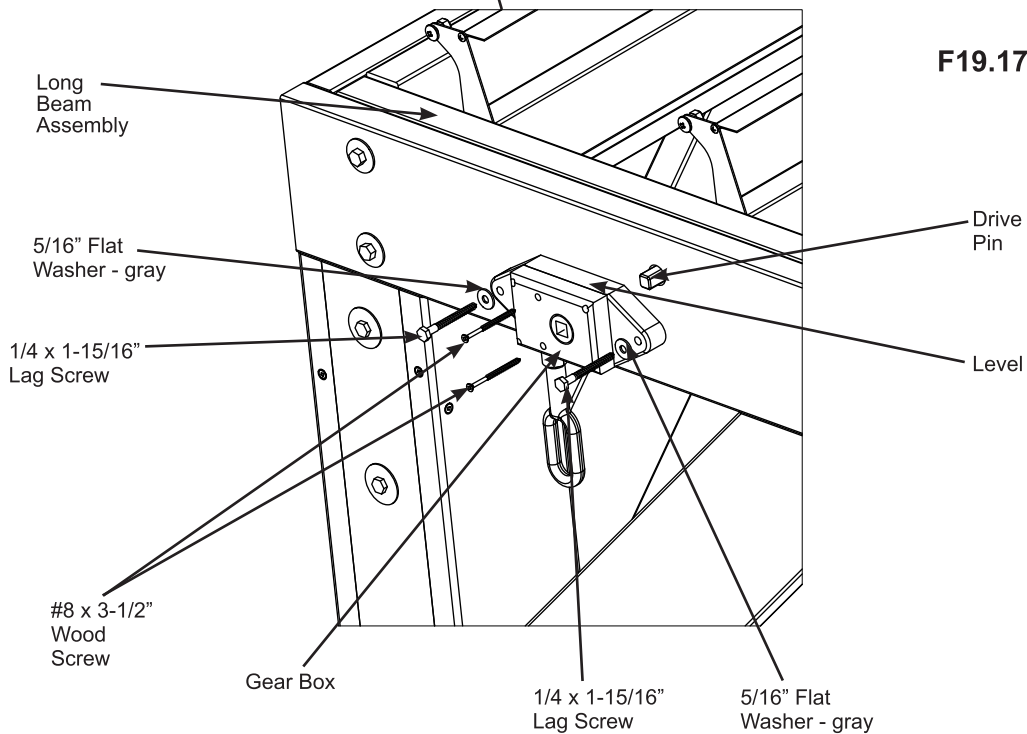
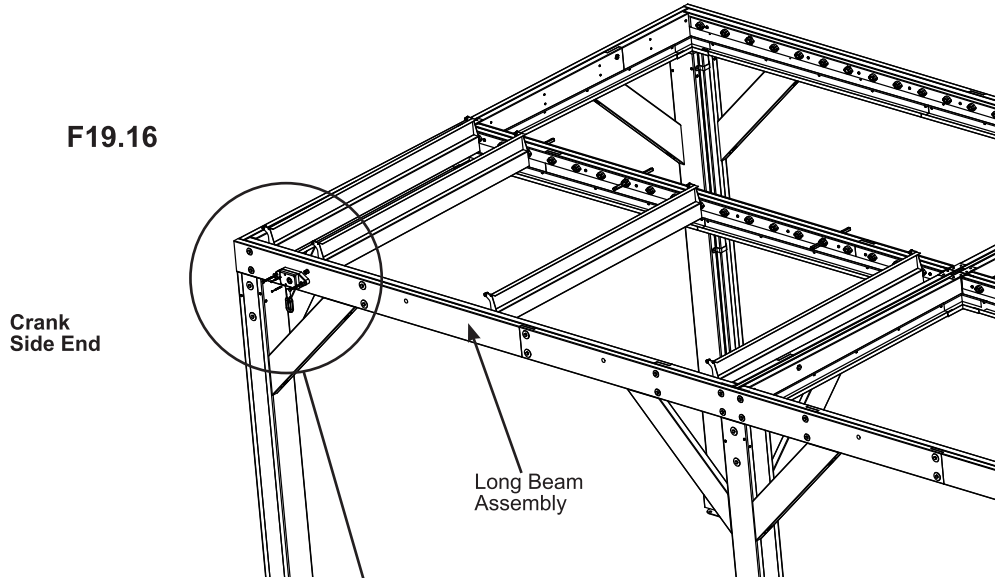

### Components

4 x Gear Box

### Hardware

8 x 1/4 x 1-15/16" Lag Screw (5/16" flat washer - gray)  
8 x #8 x 3-1/2" Wood Screw

# Step 19: Attach Louver Assemblies Part 5

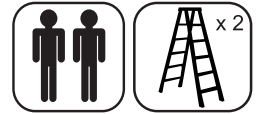

**F:** Place two Louvers without pins so the end with the bolt slot fits over the pins previously installed on the Mid Beam Assembly. Attach with two 1/4 x 1/2" Pan Bolts. (F19.18 and F19.19)

**G:** Through the outside of the Long Beam Assembly insert one Long Pin, per louver, through the bushing and into the Louver without pins. Attach with one 1/4 x 1/2" Pan Bolt. (F19.18 and F19.20)

**F19.18**

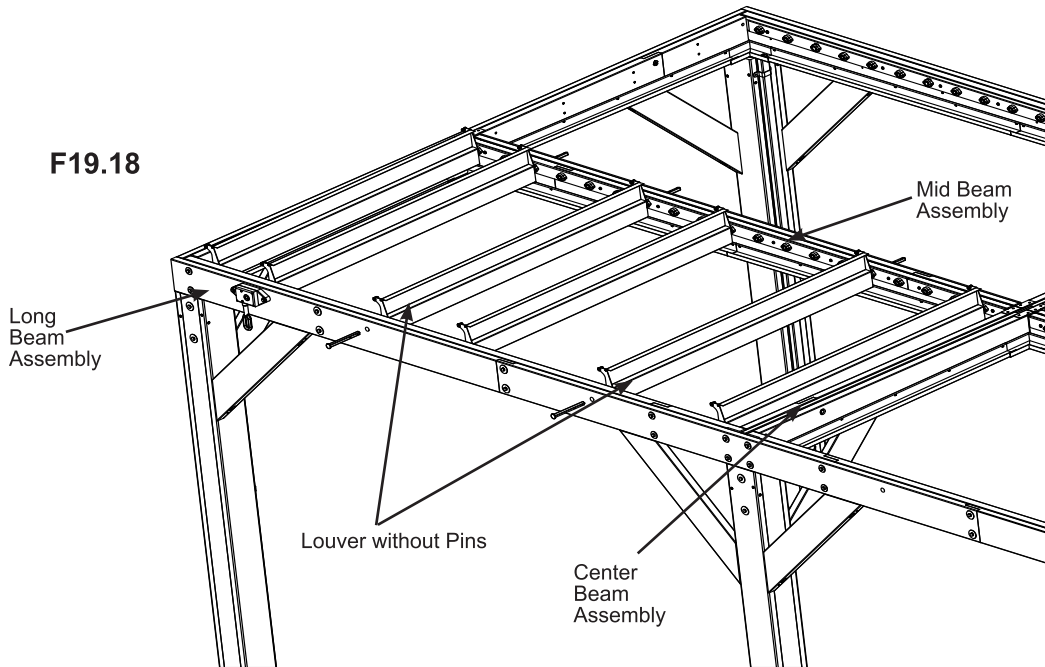

**F19.19**

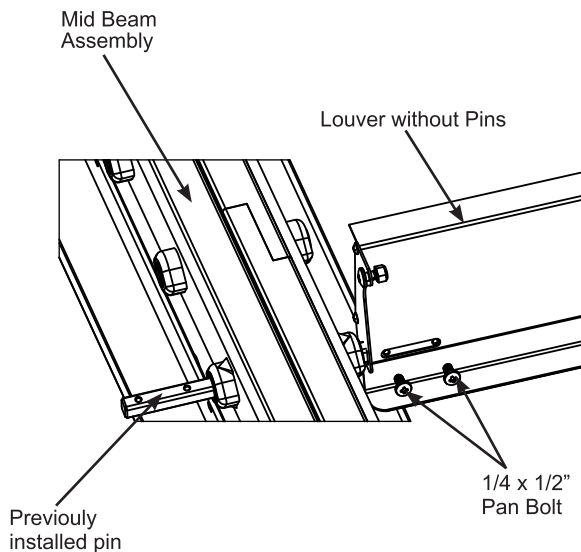

**F19.20**

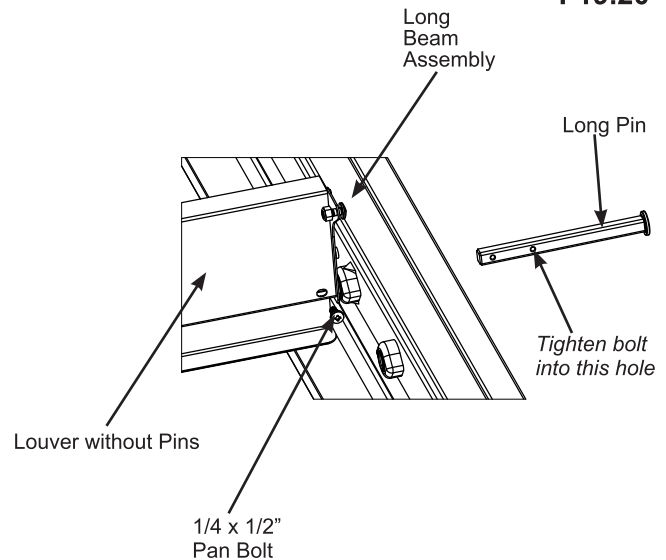

**Components**

8 x Long Pin

**Hardware**

24 x 1/4 x 1/2" Pan Bolt

# Step 19: Attach Louver Assemblies Part 6



**H:** Using the bolts, nylon washers and lock nuts previously attached to the tops of the Louver End Plates, connect one Louver Link to each end of the first three louvers. Lock nuts to be flush to end of bolt. The flange on the Louver Link to point away from Louvers. (F19.21, F19.22 and F19.23)

**I:** At the end of the Louver Link connect a second Louver Link to each end of the louver installed in Step C using the bolts, nylon washers and lock nuts previously attached to the tops of the Louver End Plates. Connect remaining louvers to Louver Links. (F19.18, F19.19 and F19.20)

*Crank Handle can be attached at this time.*

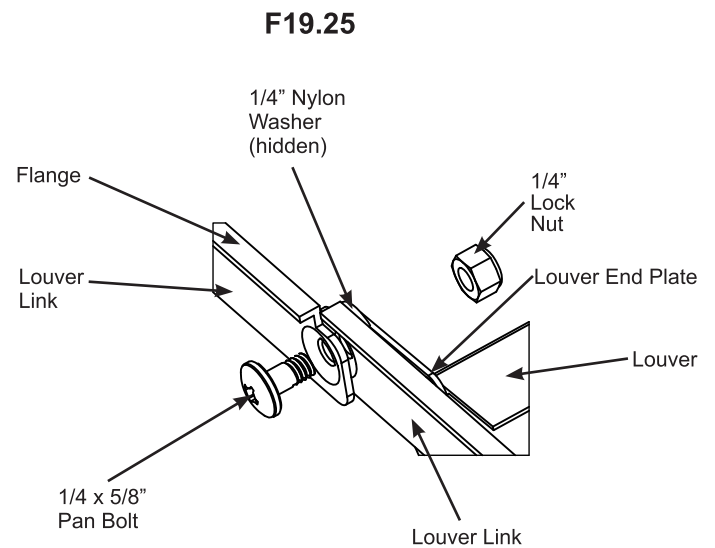
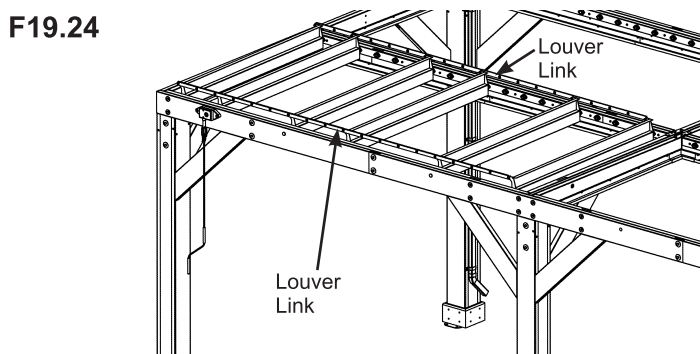
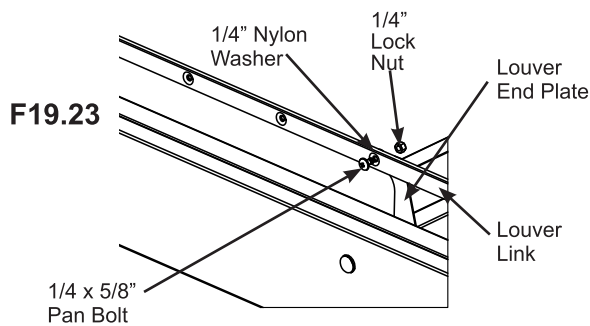
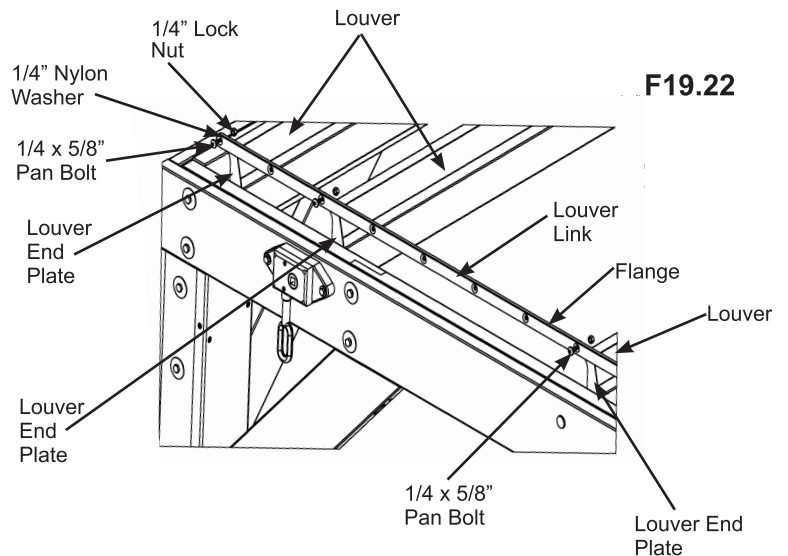
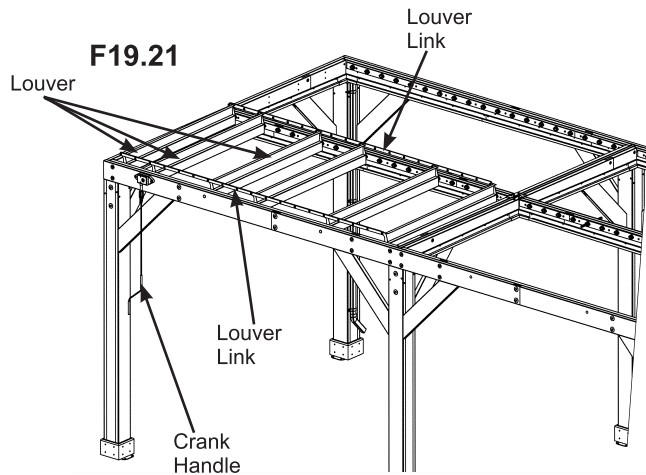

## Components

16 x Louver Link

# Step 19: Attach Louver Assemblies Part 7

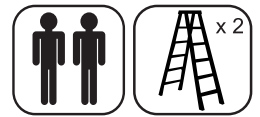

**J:** Attach 13 remaining Louvers with pins to the beams on this side of the assembly as described for the first in Steps A and B. (page 60)

**K:** Connect remaining louvers to Louver Links with previously attached bolts, nylon washer and lock nuts. (F19.26, F19.27 and F19.28)

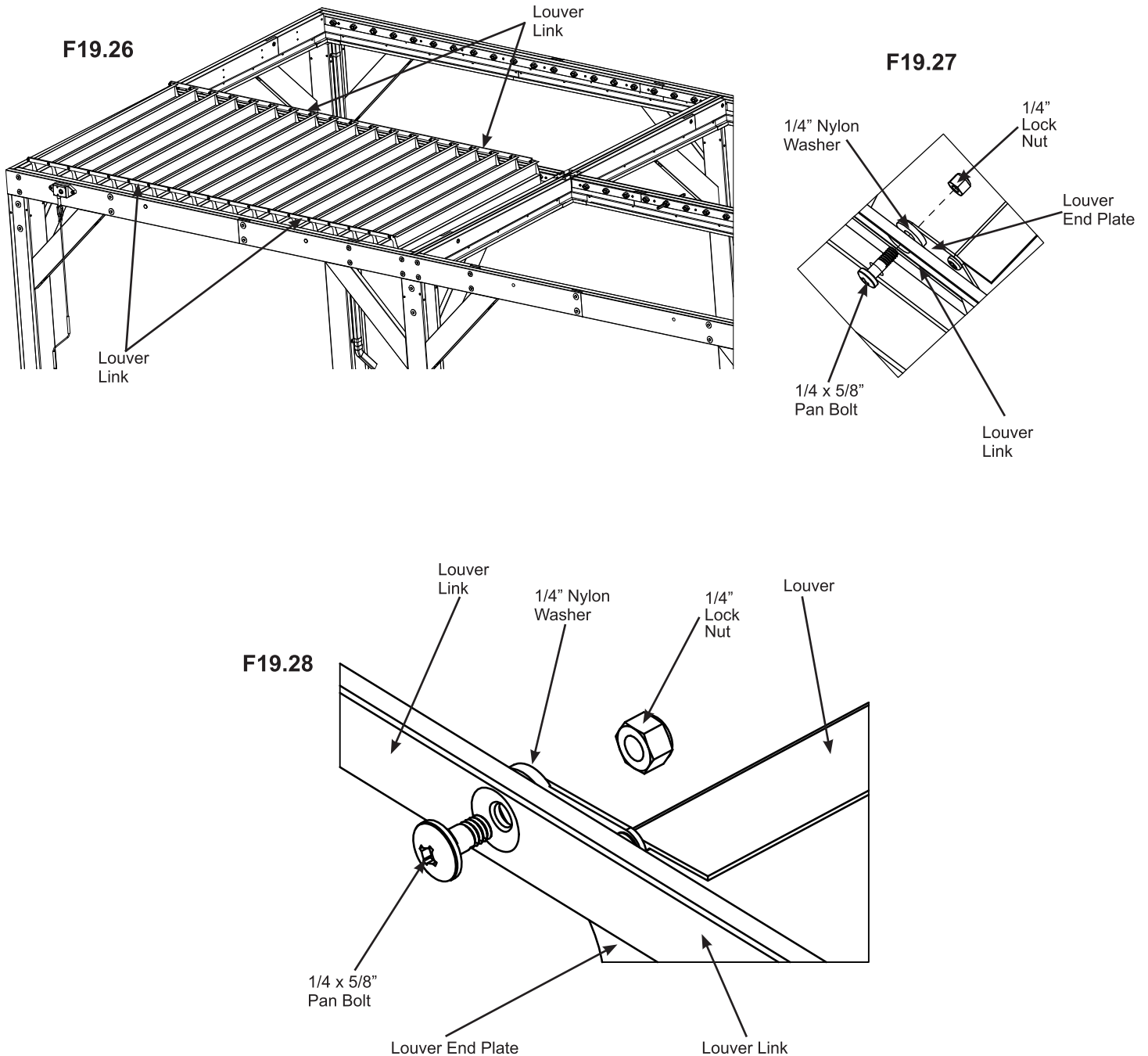

## Hardware

52 x 1/4x 1/2" Pan Bolt

## Step 20: Attach Louver Assemblies - Second Side

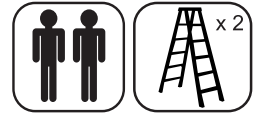

**A:** Repeat Step 19 (A - K) for the second side of the assembly.

**B:** When connecting the Louvers with and without pins for this side make sure end with bolt slot (2 bolts) is attached to the Long Beam Assembly and the end with the single bolt hole is attached to the Mid Beam Assembly. If they are not attached in this order they will not turn properly. (F20.1, F20.2 and F20.3)

**F20.2**

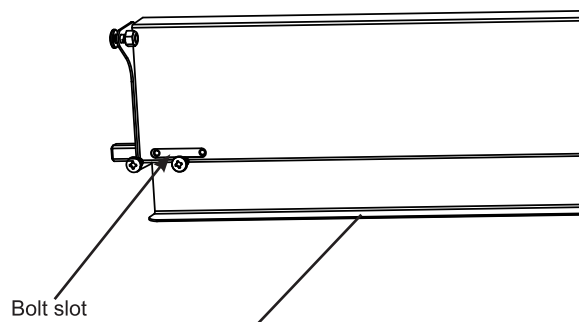

**F20.3**

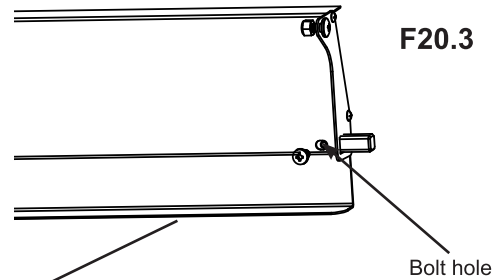

**F20.1**  
Long  
Beam  
Assembly

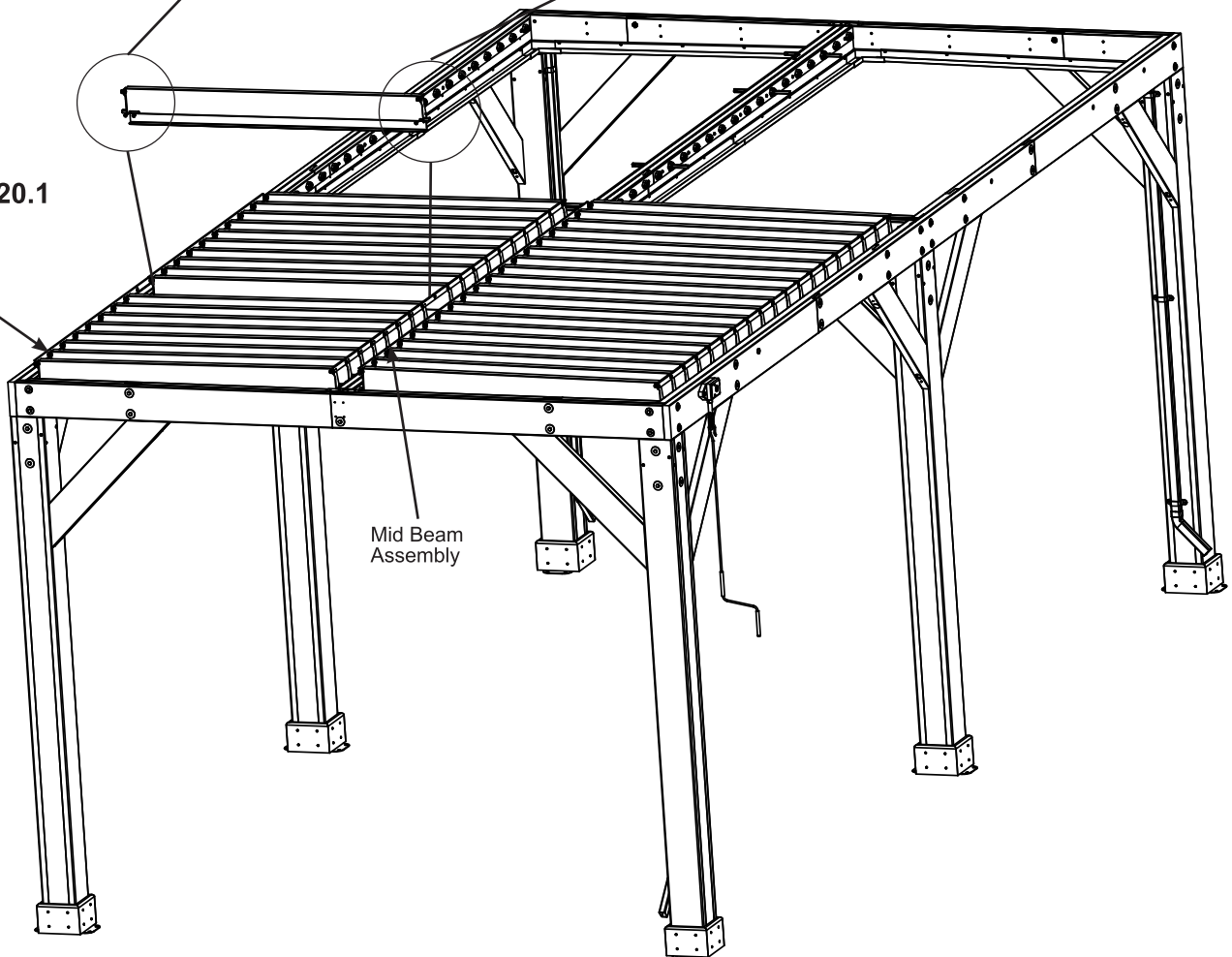



# Step 21: Attach Louver Assemblies - Second half

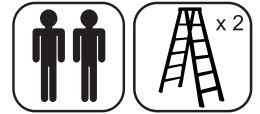

**A:** Repeat Steps 19 (A - K) and 20 for the second half of the assembly.

**B:** When connecting the Louvers with and without pins for this side make sure end with bolt slot (2 bolts) is on the left hand side and the Louver End Plates with Bolts are facing the Short Beam Assembly. If they are not attached in this order they will not turn properly. (F21.1, F21.2, F21.3, F21.4 and F21.5)

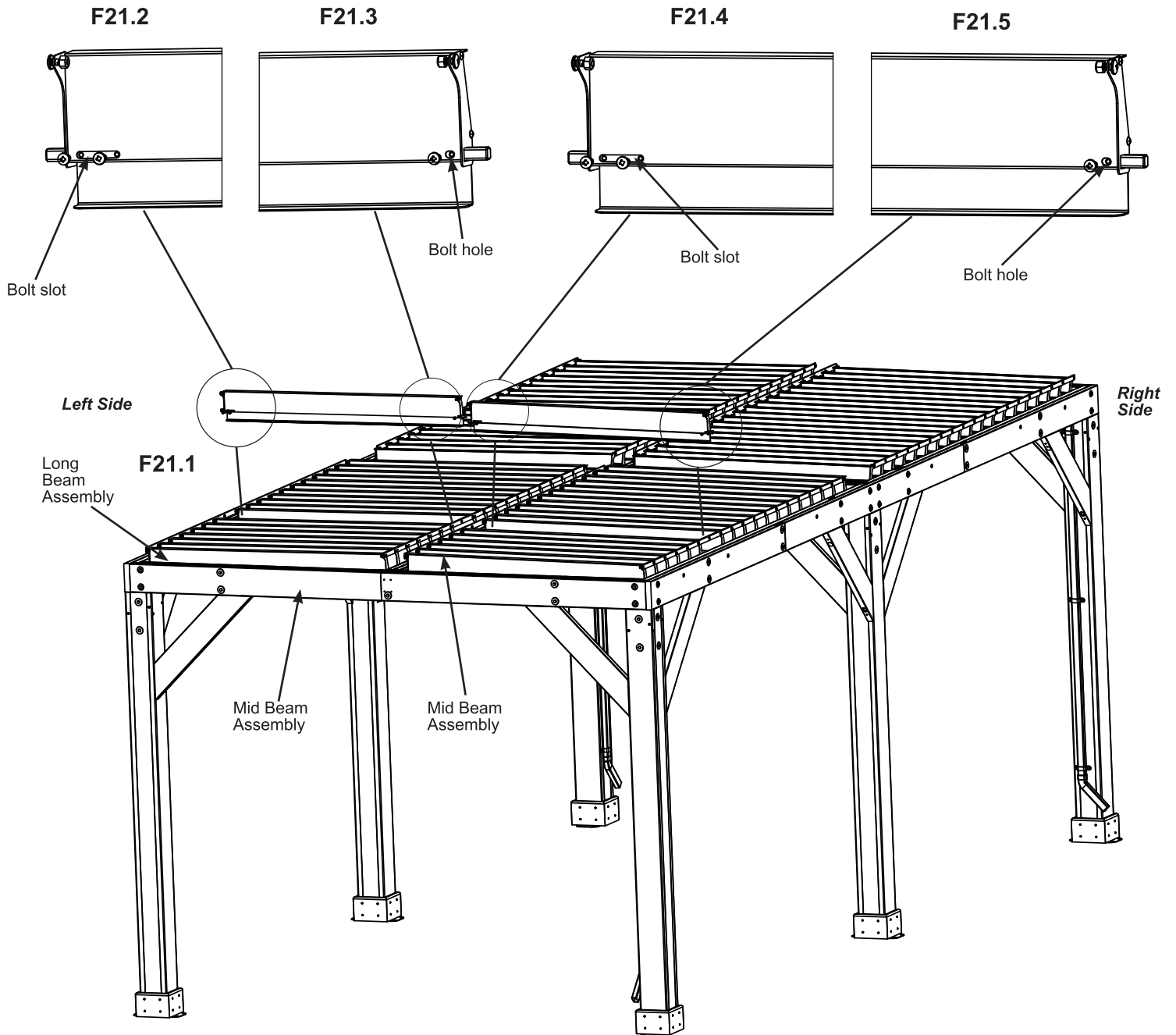

## Step 22: Attach ID Plaque



**A:** Attach Gazebo ID Plaque to a prominent location on your gazebo with two #10 x 1-1/4" Pan Screws. This provides warnings concerning safety and important contact information. A tracking number is provided to allow you to get critical information or order replacement parts for this specific model. (F22.1 and F22.2)

F22.1

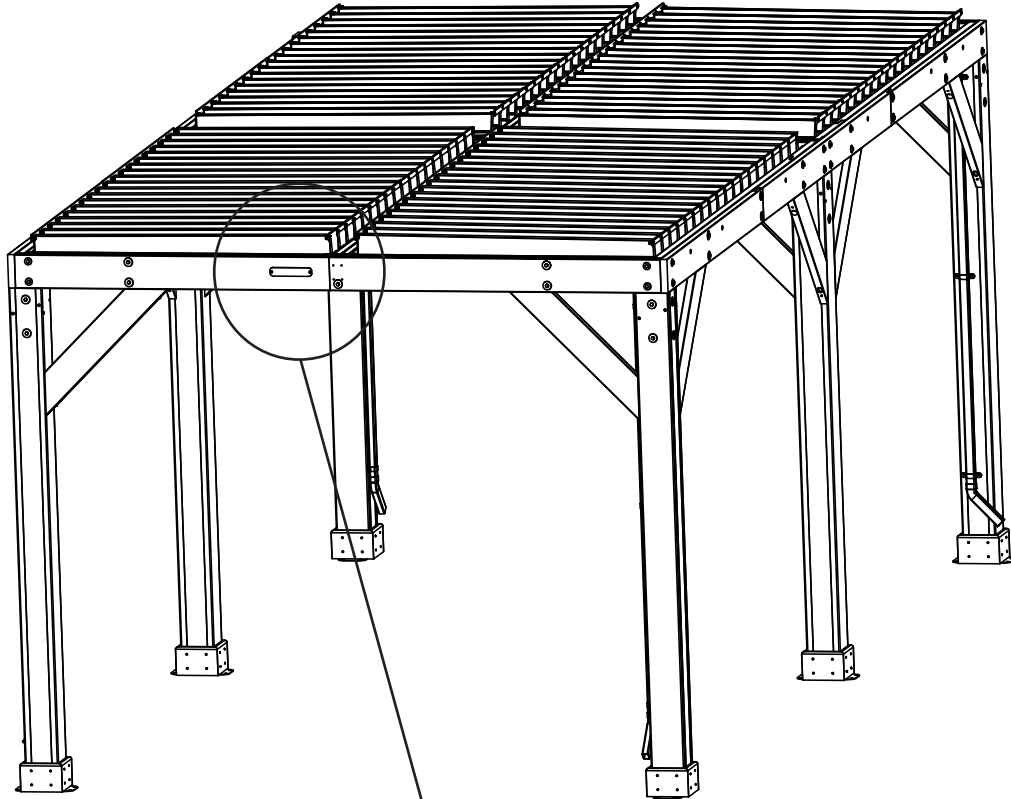

F22.2

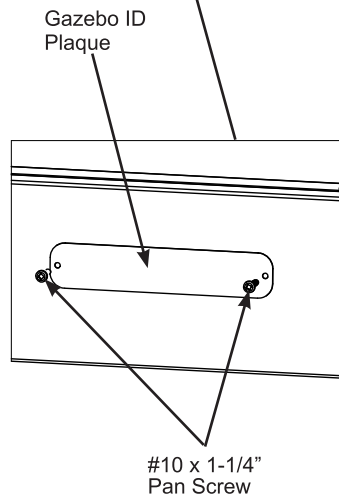

**Components:**

1 x Gazebo ID Plaque

**Hardware**

2 x #10 x 1-1/4" Pan Screw

# Step 23: Gear Box Lockout and Winter Maintenance



**A:** To lock the Gear Box remove the Crank Handle then attach Lock Out to each Gear Box using the Quick Link to secure in place. (F23.1 and F23.2)

**IMPORTANT!** When preparing for high winds and/or winter conditions, turn the louvers to the open position (upright) then attach the Lock Out and Quick Link. This will prevent the structure from blowing over due to high winds and the louvers from breaking due to snow and ice loads. (F23.1 and F23.2)

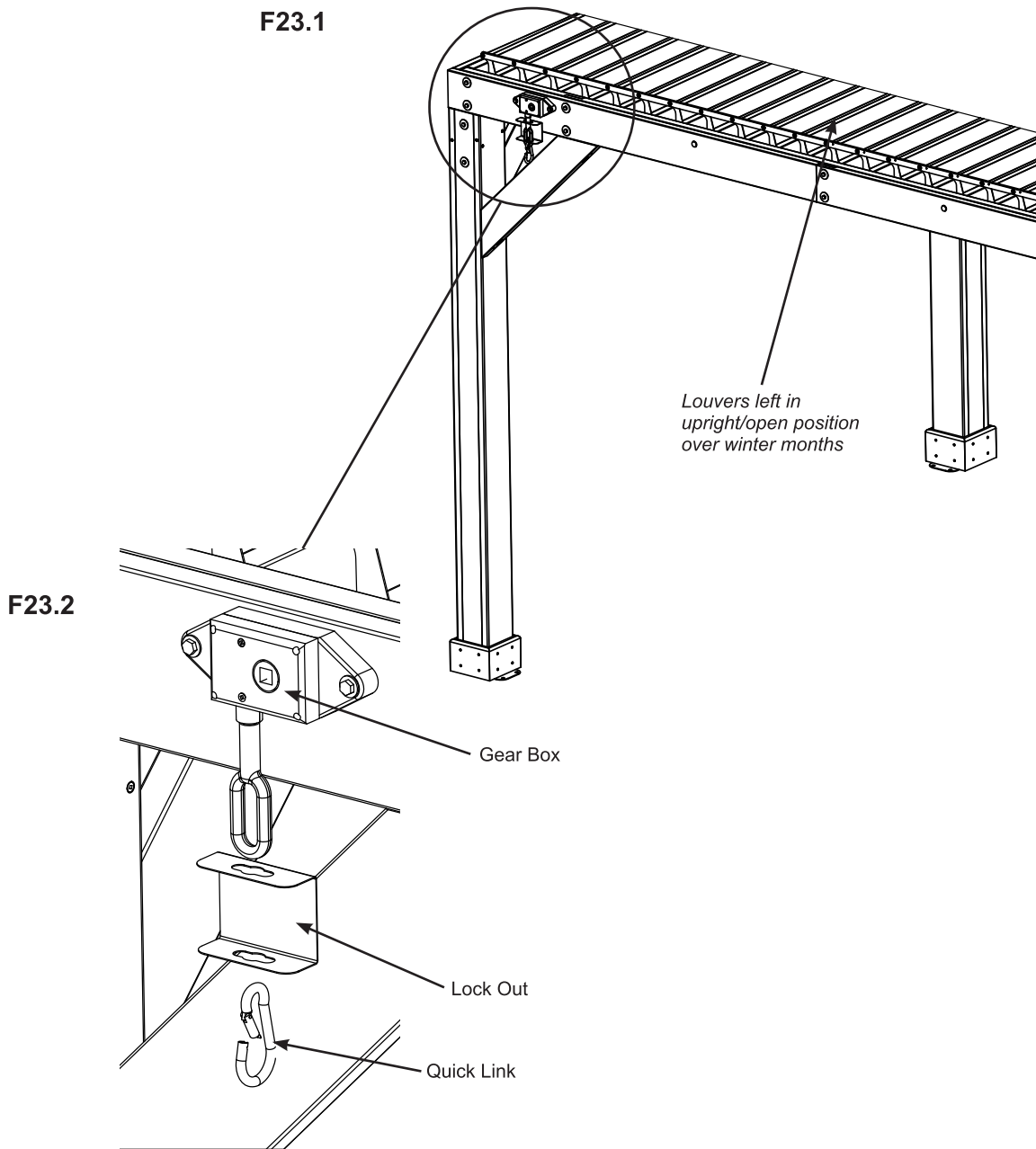

**Components:**

- 4 x Lock Out
- 4 x Quick Link

## NOTES

---

---

---

---

---

---

---

---

---

---

---

---

---

---

---

---

---

---

---

---

---

---

---

---

---

---



## Customer Registration Card - Tarjeta de Registro del Cliente - Carte d'inscription du client

First Name - Primer Nombre - Prénom	Initial - Inicial - Initiale	Last Name - Apellido - Nom de famille

Street - Calle - Rue	PO Box - Casilla postal - Boîte postale	Apt. No. - App.

City - Ciudad - Ville	State/Province - Estado/Provincia - État/Province

ZIP/Postal Code - Código Postal - ZIP/Code postal	Country - País - Pays

E-mail Address - Dirección de E-mail - Adresse courriel	Telephone Number - No. de Teléfono - N° de téléphone

Model Name - Nombre del Modelo - Nom du modèle	Model Number (from front cover) - Número de Modelo (de la portada) - N° du modèle (page de couverture)

Date of Purchase - Fecha de Compra - Date d'achat (mm/dd/yyyy) (mm/dd/aaaa) (mm/jj/aaaa)	Place of Purchase - Comprado a - Lieu d'achat

Comments - Comentarios - Commentaires:

### Mail To - Enviar por Correo a - Envoyer par courrier à:

Yardistry  
375 Sligo Road West, PO Box 10  
Mount Forest, Ontario, Canada, N0G 2L0  
Attention: Consumer Relations  
Atención a: Servicio de Atención al Cliente  
À l'attention de: Service à la clientèle

### Online Registration - Registro online - Enregistrement en ligne:

[www.yardistrystructures.com/warranty](http://www.yardistrystructures.com/warranty)

Hours/ Heures/ Horas: 8:30 am - 5:00 pm EST  
(excl. holidays/ hors jours fériés/ excepto los días festivos)

English and French Spoken / Anglais et français parlés / Inglés y francés hablado

Yardistry would like to say "Thank you" for your time and feedback.

Yardistry quiere "Agradecerle" por su tiempo y su opinión.

Yardistry aimerait vous remercier d'avoir pris le temps de répondre au sondage.