

# Step 10: Check Frame Dimensions

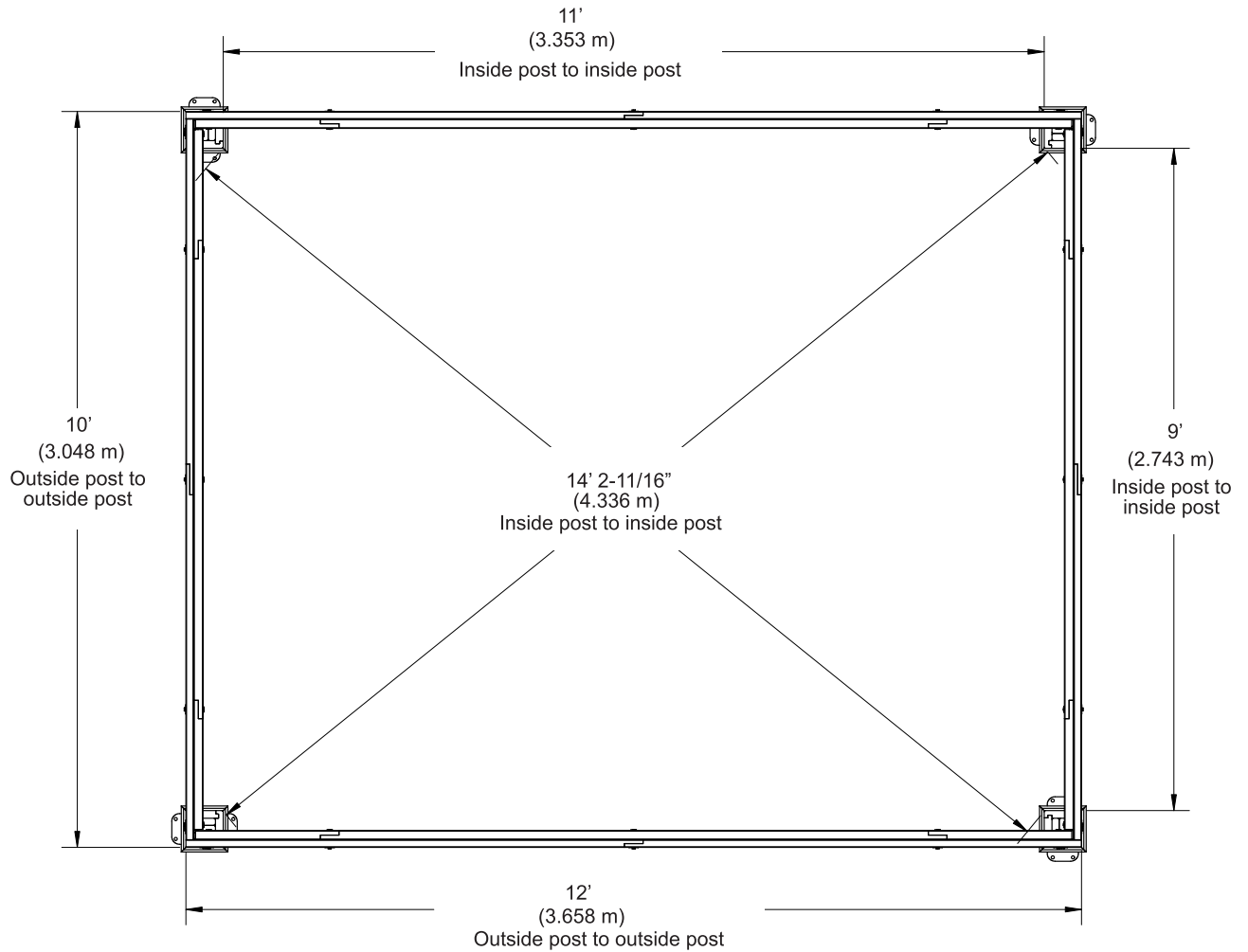

**A:** The diagonal distance between the inside of two posts should be 170-11/16" (4.336 m) (measuring from posts not from Post Mounts. (F10.1)

## F10.1



# Step 11: Attach Middle Beam Assembly Part 1



**A:** On each Short Beam Assembly, at the lap where two (1331) Short Side Beams meet, measure 2-1/2" (6.35 cm) and mark the spot. (F11.1)

**B:** Place Middle Beam Assembly at the centre of each Short Beam Assembly so the middle of each (1295) Middle Beam Center line up with the previously marked location on the Short Beam Assembly. Make sure Axle Through Pin Shorts are at the top of the beam. They will be aligned with the holes for the Crank. Attach Centre Beam Brackets LT/RT to Short Beam Assemblies with six #8 x 1-1/2" Wood Screws per bracket. (F11.2, F11.3 and F11.4)

**F11.1**  
*Top View*

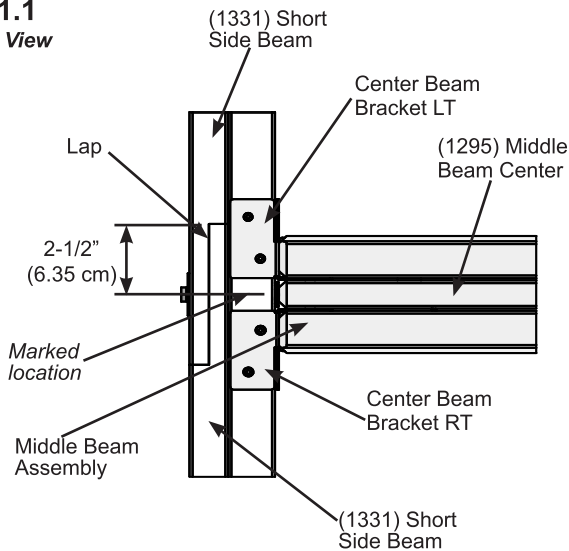

**F11.2**

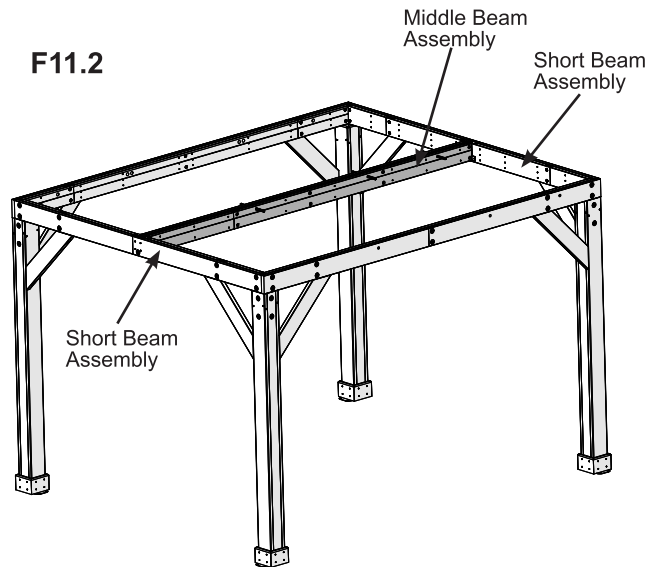

**F11.3**

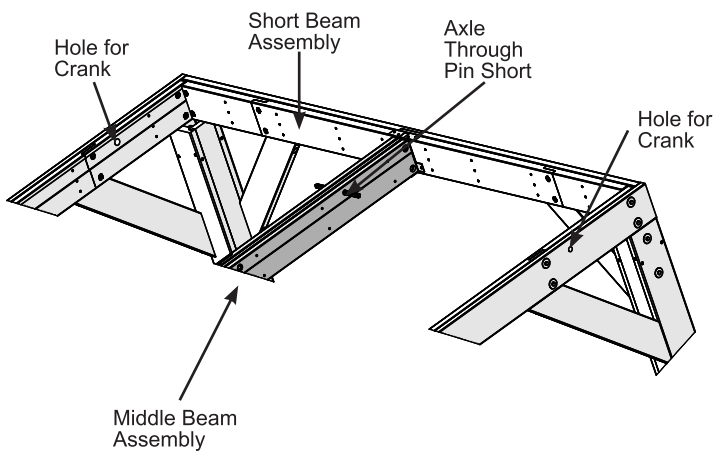

**F11.4**  
*Inside View*

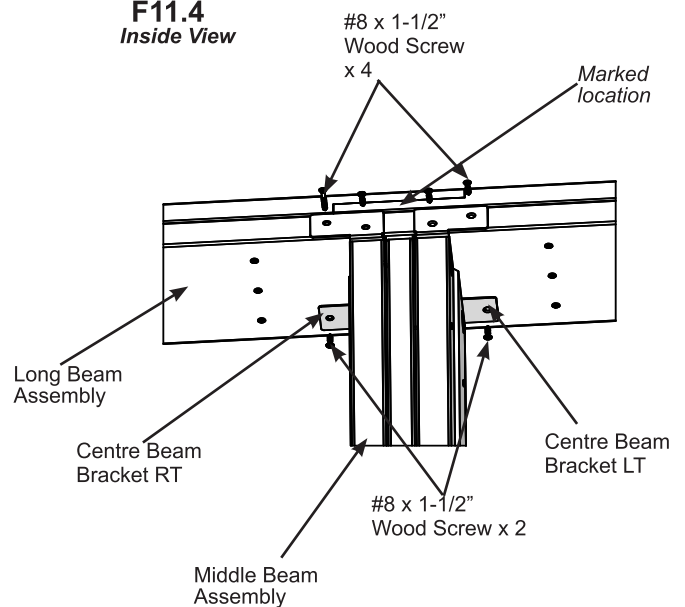

**Hardware**

12 x #8 x 1-1/2" Wood Screw

# Step 11: Attach Middle Beam Assembly Part 2

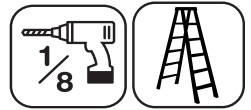

**C:** Predrill with a 1/8" drill bit then attach Short Beam Assemblies to Middle Beam Assembly with four #10 x 4" Wood Screws per end. (F11.5)

**F11.5**  
*Outside View*

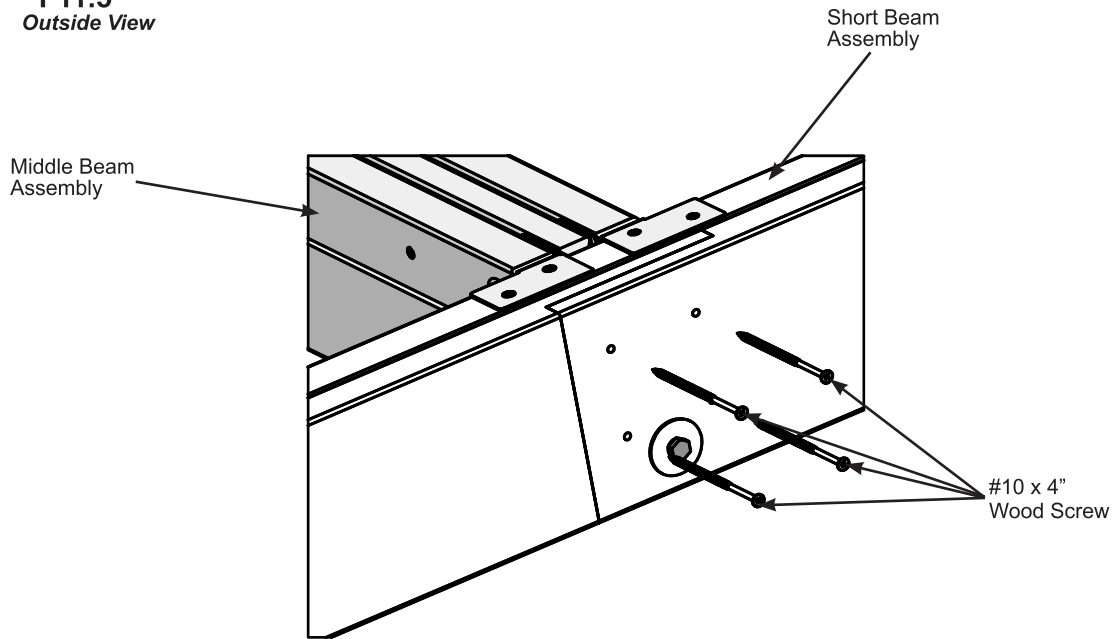

**Hardware**

8 x #10 x 4" Wood Screw

# Step 12: Attach Louvered Rails Part 1



**A:** On the inside of each Long Beam Assembly, in the groove, place one Louver Rail Assembly 2378.3. Make sure the rail is oriented so the third bushing (with arrow on top) is lined up with the hole for the Crank. Attach to Long Beam Assembly with eight #8 x 1" Pan Screws. (F12.1 and F12.2)

**B:** Tight to each Louver Rail Assembly 2378.3 place one Louver Rail Assembly 1129 then attach with four #8 x 1" Pan Screws. (F12.1 and F12.2)

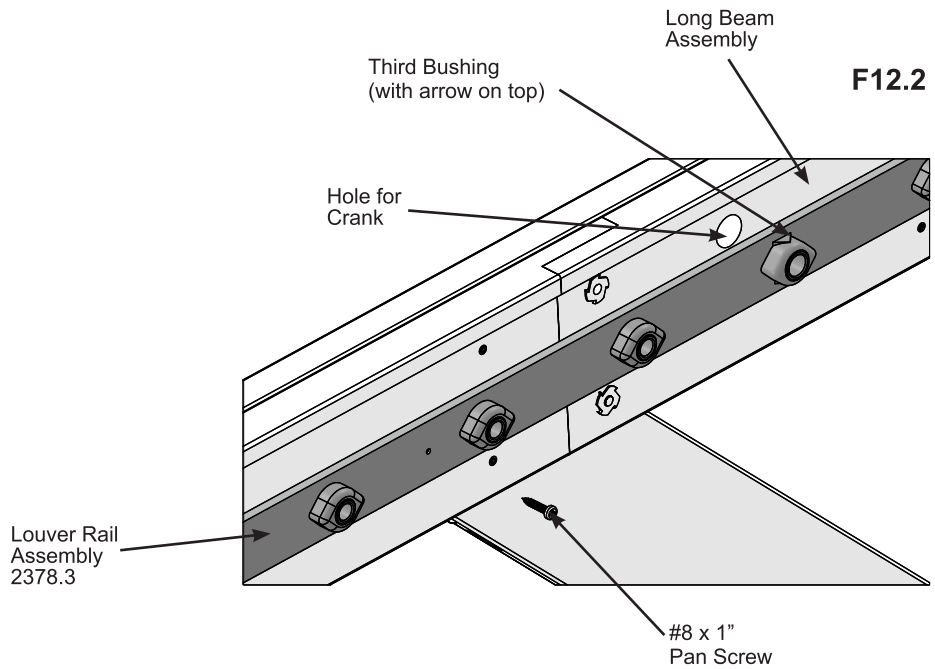
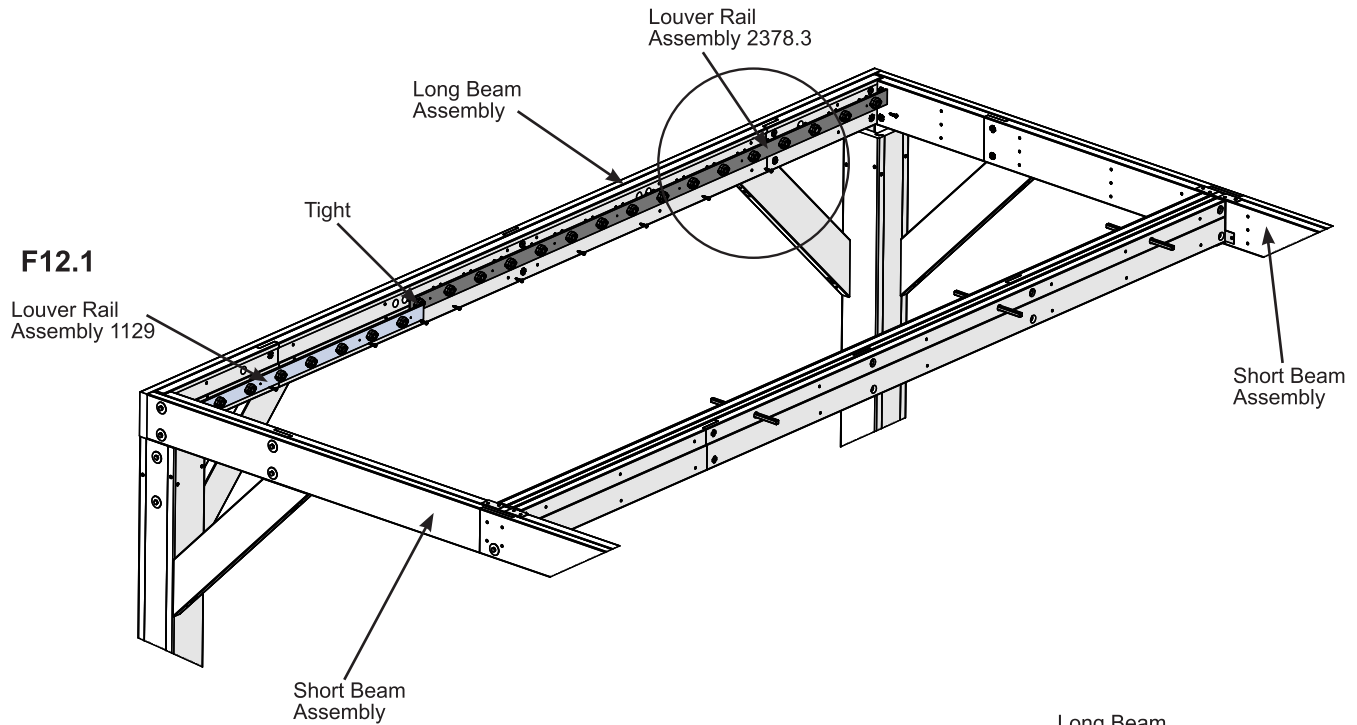

### Components

2 x Louver Rail Assembly 2378.3  
2 x Louver Rail Assembly 1129

### Hardware

24 x #8 x 1" Pan Screw

# Step 12: Attach Louvered Rails Part 2



**C:** On each side of the Middle Beam Assembly, in the groove, place one Louver Rail Assembly 2378.3. Make sure the rail is oriented so the three bushings (with arrow on top) are inserted over the three Axle Through Pin Shorts. Attach to Middle Beam Assembly with eight #8 x 1" Pan Screws. (F12.3 and F12.4)

**B:** Tight to each Louver Rail Assembly 2378.3 place one Louver Rail Assembly 1129 then attach with four #8 x 1" Pan Screws. (F12.3 and F12.4)

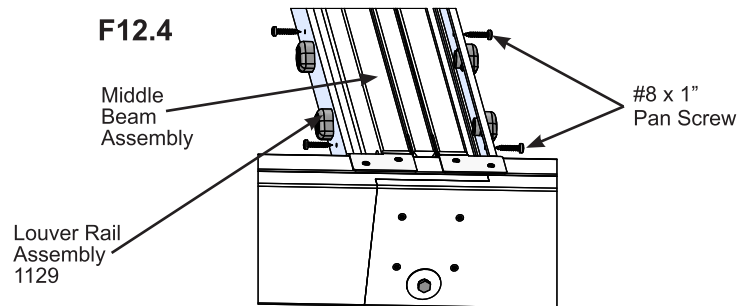
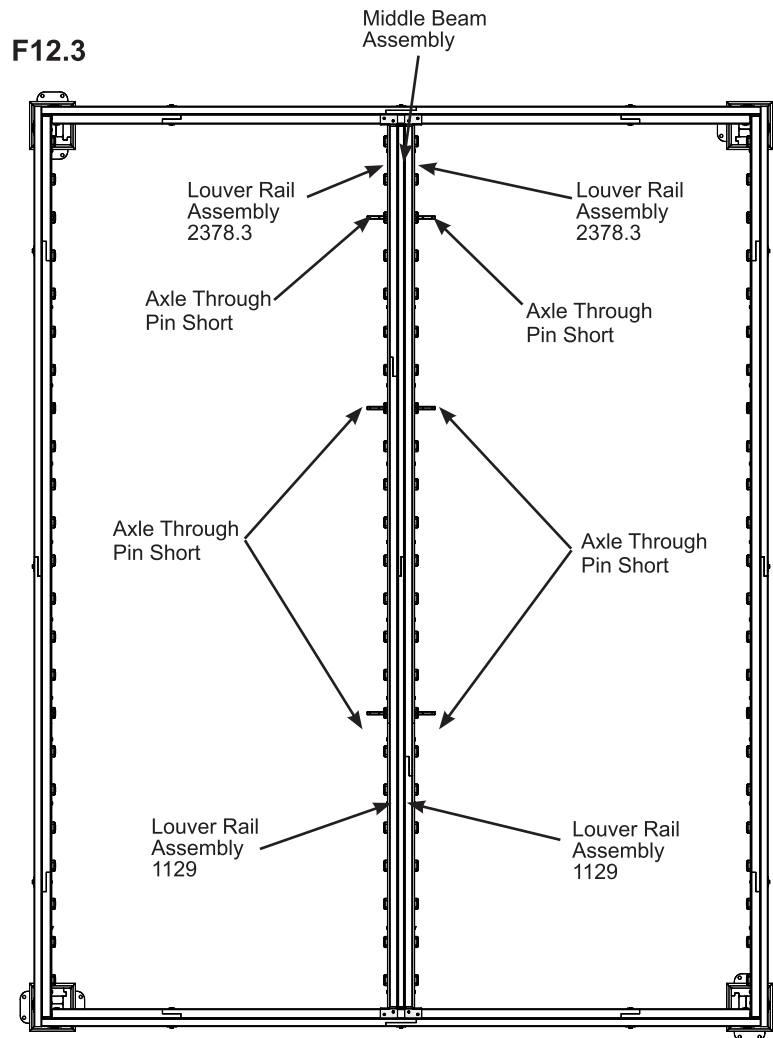

### Components

2 x Louver Rail Assembly 2378.3  
2 x Louver Rail Assembly 1129

### Hardware

24 x #8 x 1" Pan Screw

# Step 13: Attach Gutter Drain Corners

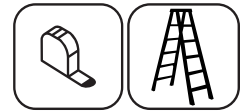

**A:** Measure approximately 1/2" (1.27 cm) in from both edges of each Gutter Drain Corner then apply a small bead of sealant. (F13.1 and F13.2)

**B:** On each Long Beam Assembly there will be one Gutter Drain Corner. Choose which post along the Long Beam Assembly the water is going to drain from. (F13.3)

**C:** On each Post Assembly place one Gutter Drain Corner so it is tight to the Long and Short Beam Assemblies. Do not attach at this step. (F13.3 and F13.4)

**F13.1**

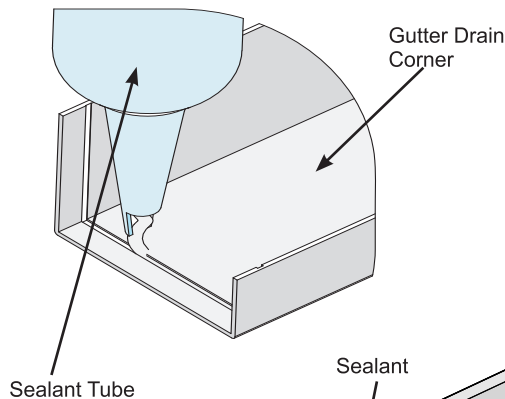

**F13.2**

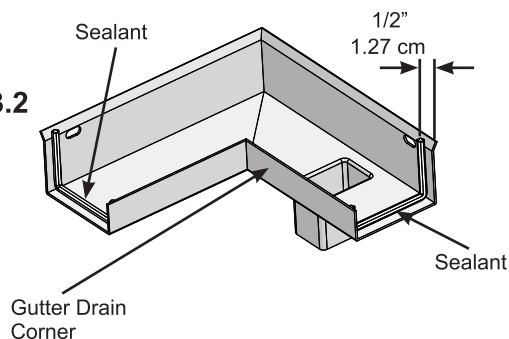

**F13.3**

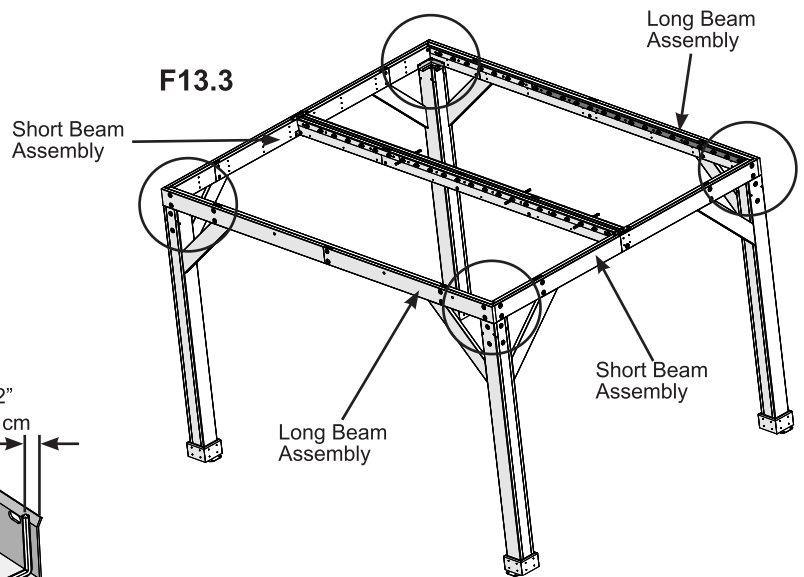

**F13.4**

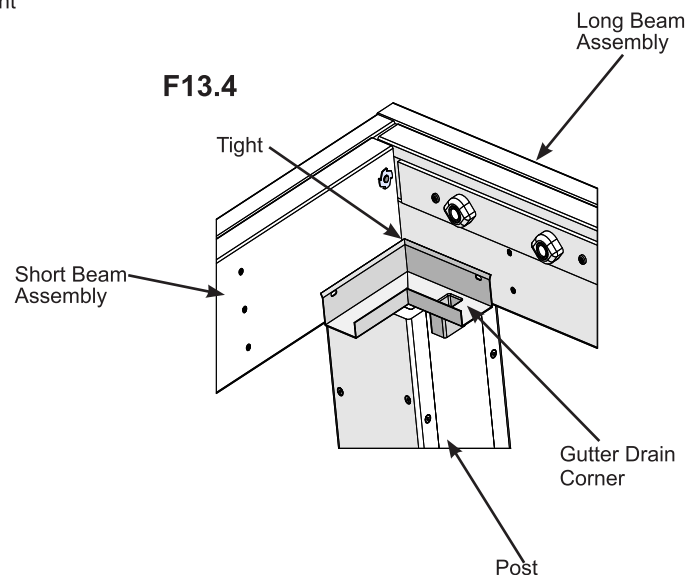

**Note:** All surfaces to be clean, dry, dust and grease free before application with temperatures above 5°C (41°F), no warmer than 35°C (95°F).

- Remove cap and cut a small piece off the nozzle for a small bead.
- Apply sealant in small beads and smooth as required.
- Clean excess with a cloth or paper towel before it skins over.
- Always wear safety glasses and rubber gloves when using product.

**See page 6 for Warning and First Aid Information.**

## Components

2 x Gutter Drain Corner  
Sealant

# Step 14: Attach Post Blocks



**A:** At the Post Assembly (without the Gutter Drain Corner) place one (1332) Post Block tight to the Long and Short Beam Assemblies. Attach each (1332) Post Block to posts with two #8 x 2-1/2" Wood Screws. (F14.1 and F14.2)

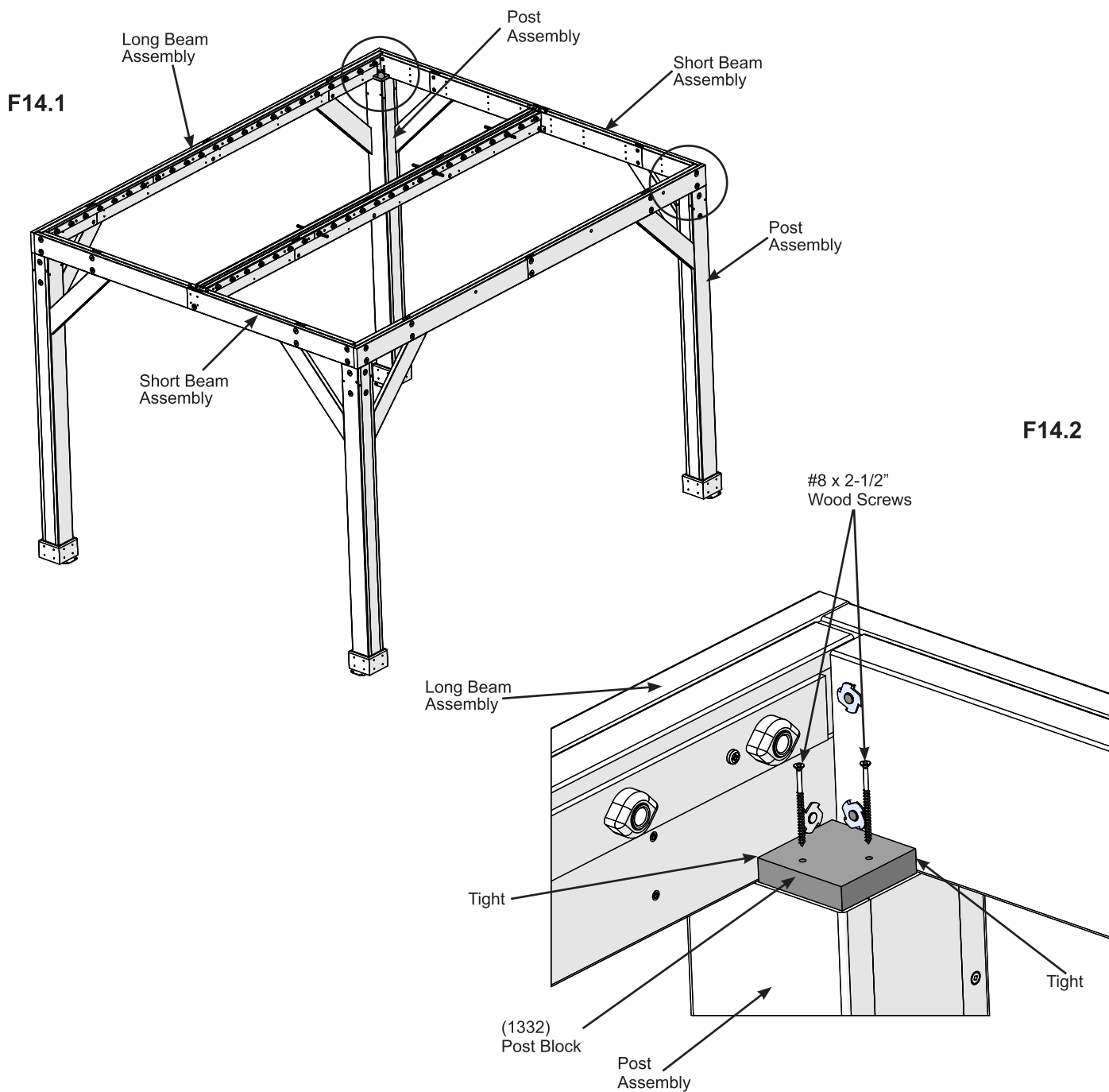

### Wood Parts

2 x (1332) Post Block

### Hardware

4 x #8 x 2-1/2" Wood Screw

# Step 15: Rain Gutter Assembly Part 1

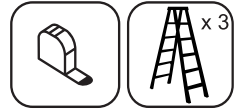

**A:** Measure approximately 1/2" (12.7 mm) in from both edges of six Gutter Corners and four Gutter Connectors then apply a small bead of sealant, as shown in F15.1, F15.2 and F15.3.

**B:** Place Gutter Corner on one (1332) Post Block tight to the Long and Short Beam Assemblies. (F15.4 and 15.5)

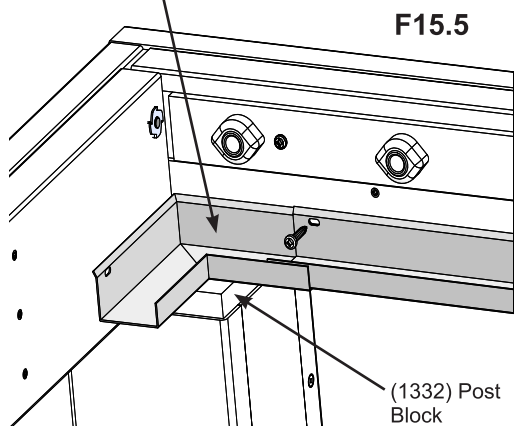
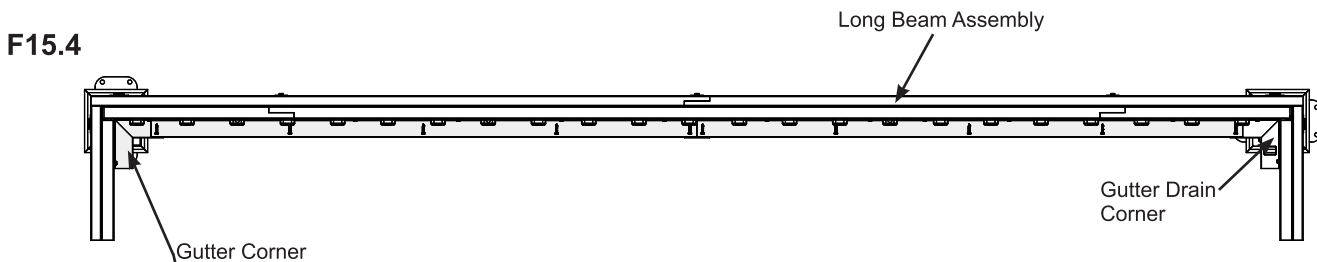
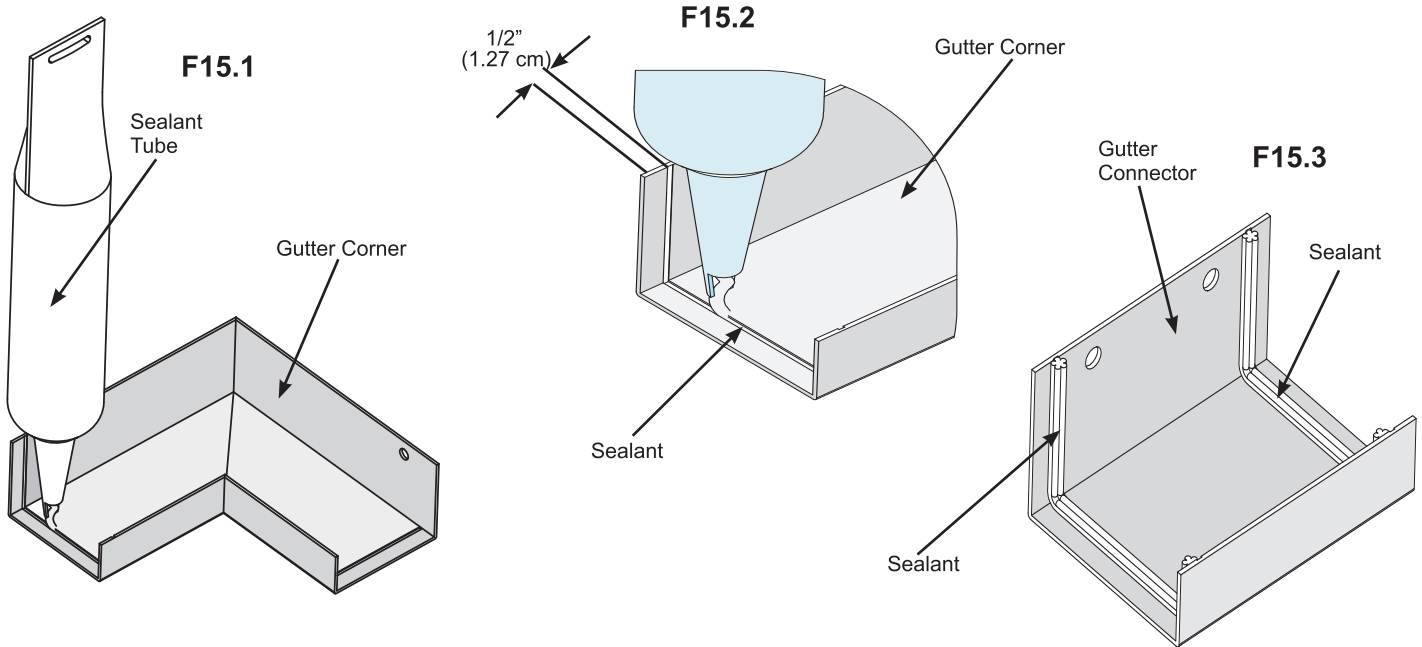

**Note:** All surfaces to be clean, dry, dust and grease free before application with temperatures above 5°C (41°F), no warmer than 35°C (95°F).

- Apply sealant in small beads and smooth as required.
- Clean excess with a cloth or paper towel before it skins over.
- Always wear safety glasses and rubber gloves when using product.

**See page 6 for Warning and First Aid Information.**

## Components

- 6 x Gutter Corner
- 4 x Gutter Connector
- Sealant



# Step 15: Rain Gutter Assembly Part 2



**C:** Slide one Rain Gutter I into Gutter Corner along the Long Beam Assembly then place one Gutter Connector at the end of Rain Gutter I. Gutter Connector to sit  $3/8''$  (0.95 cm) up from bottom of beam. (F15.6, F15.7, F15.8 and F15.9)

**D:** Slide one Rain Gutter I into Gutter Drain Corner along the Long Beam Assembly and into Gutter Connector. (F15.6, F15.8 and F15.10).

**E:** Attach, Rain Gutters to Short Beam Assembly with 10 #8 x 1" Pan Screws. (F15.6, F15.7, F15.8 and F15.10)

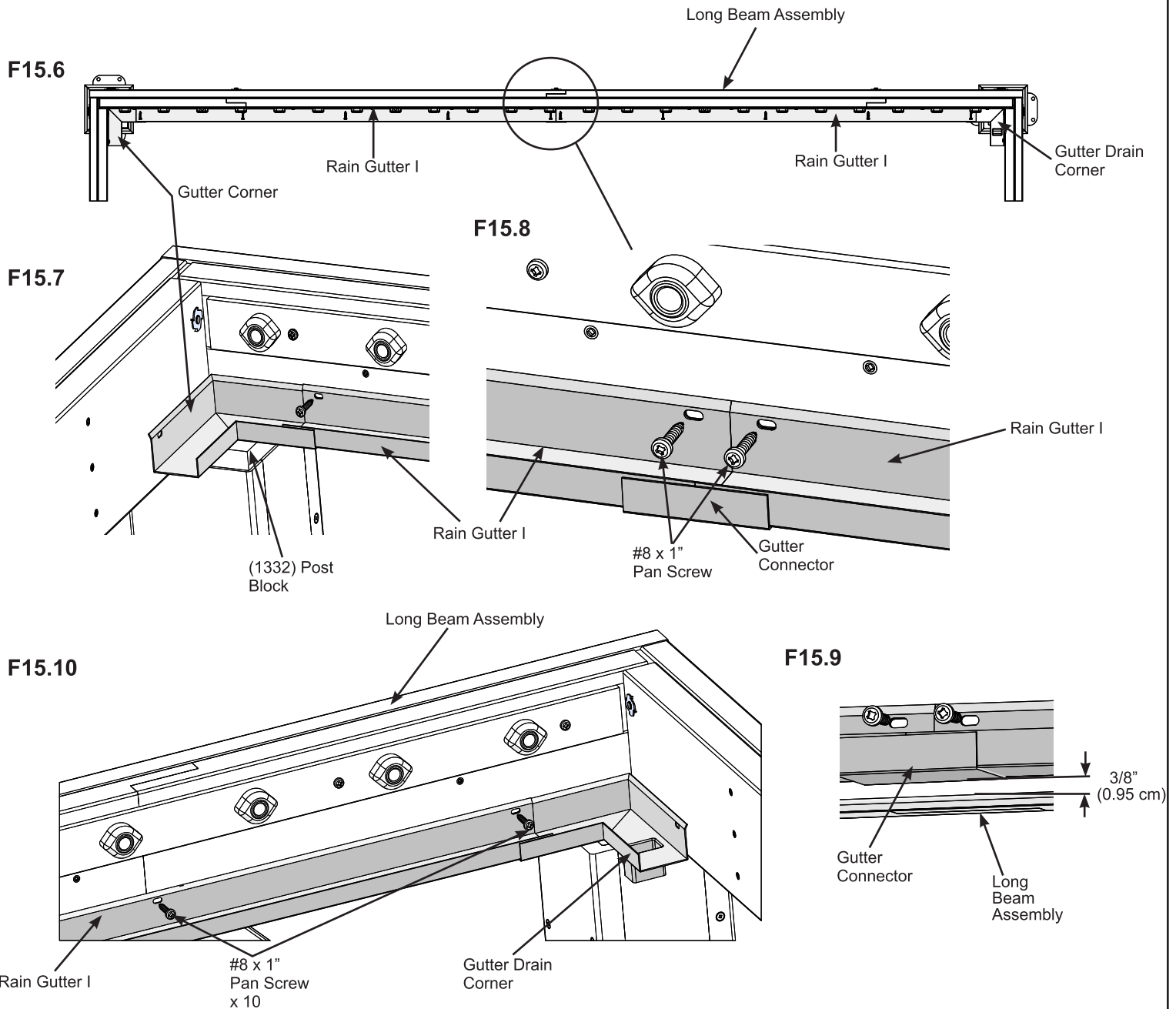

### Components

4 x Rain Gutter I

### Hardware

20 x #8 x 1" Pan Screw

# Step 15: Rain Gutter Assembly

## Part 3



**F:** On the drain side end of the Mid Beam Assembly place one Gutter Corner flush to the bottom of the beam. Have one helper hold it in place. (F15.11 and F15.12)

**G:** On the non drain side end of the Mid Beam Assembly measure 3/4" (1.91 cm) up from the bottom of the beam and place one Gutter Corner. Have one helper hold it in place. (F15.11 and F15.13)

**H:** Slide one Rain Gutter I into each Gutter Corner along the Mid Beam Assembly with a Gutter Connector in the middle as done for the Long Beam Assembly. Gutter Connector to sit 3/8" (0.96 cm) up from bottom of beam. (F15.11, F15.12, F15.13 and F15.14)

**I:** Attach, Rain Gutters to Mid Beam Assembly with 10 #8 x 1" Pan Screws. (F15.11 and F15.14)

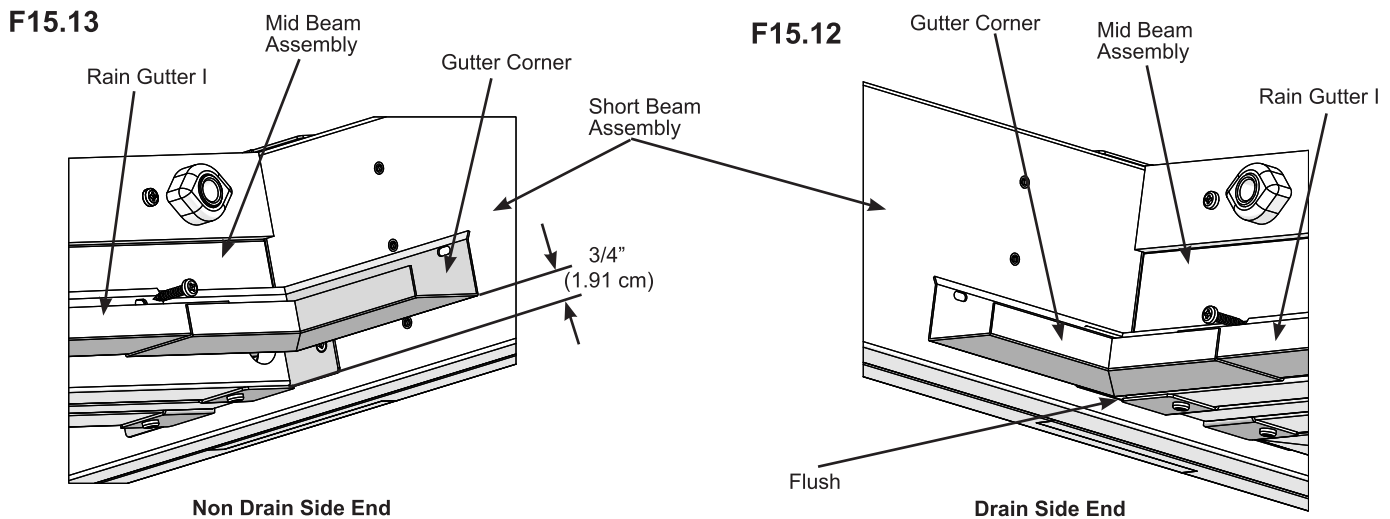
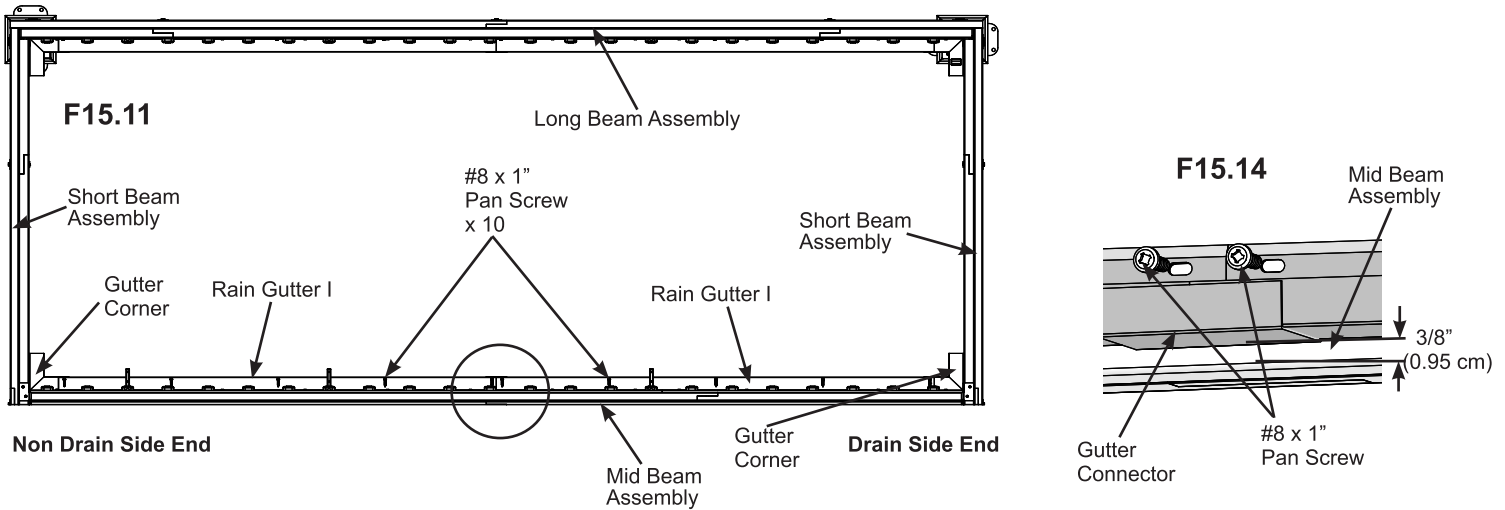

### Components

4 x Rain Gutter I

### Hardware

20 x #8 x 1" Pan Screw

# Step 15: Rain Gutter Assembly

## Part 4



**J:** On each Short Beam Assembly slide one Rain Gutter G into each Gutter Corner and Gutter Drain Corner then attach with five #8 x 1" Pan Screws. (F15.15 and F15.16)

**K:** Repeat Steps A - J for second side of the assembly.

**F15.15**

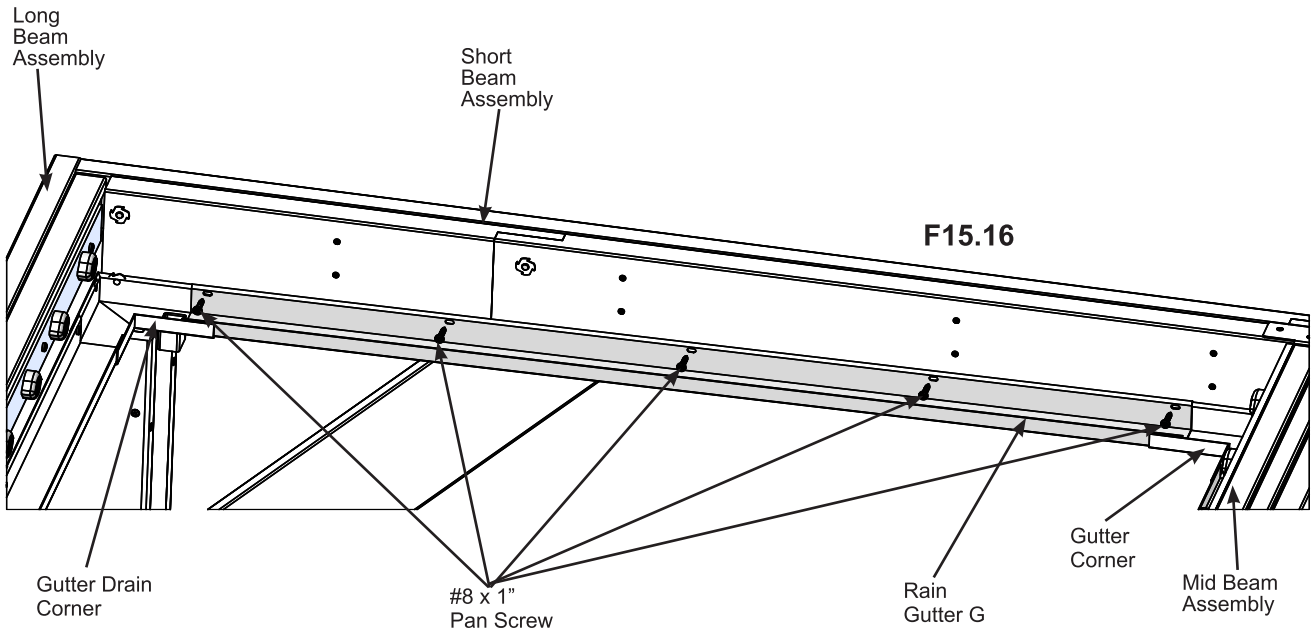
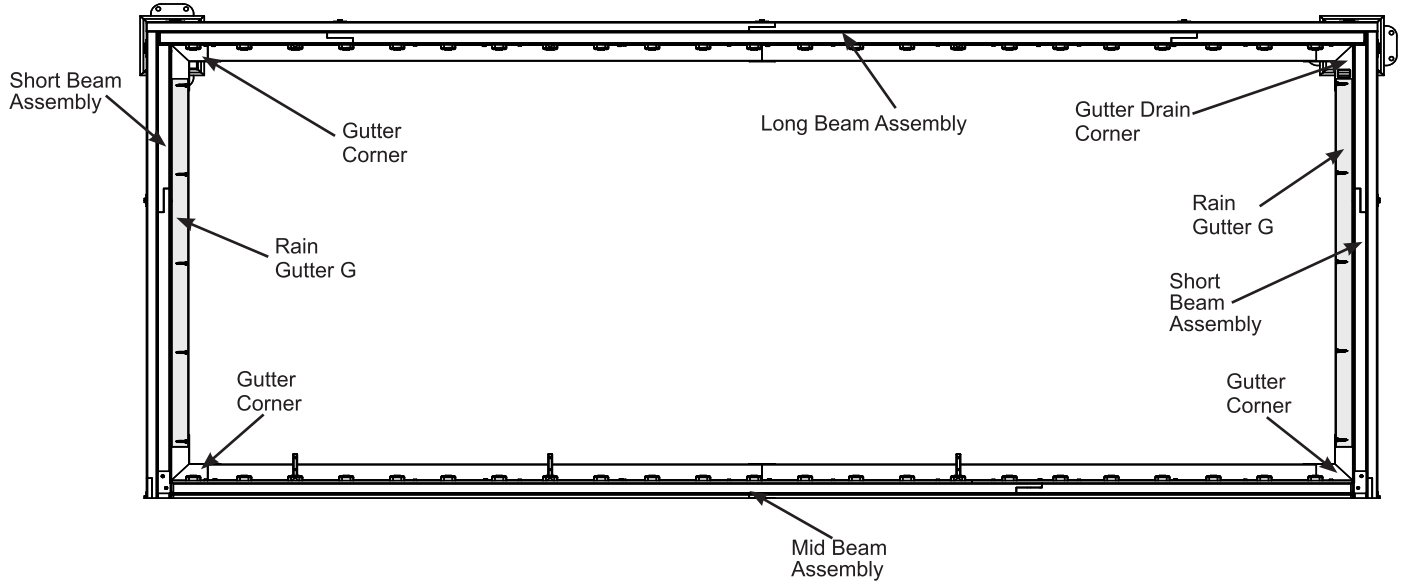

**Components**

4 x Rain Gutter G

**Hardware**

20 x #8 x 1" Pan Screw

# Step 16: Apply Sealant Part 1



**A:** At each end of Rain Gutter I and Rain Gutter G apply a small, evenly distributed bead of sealant over the connector joints. Smooth sealant into the joint so it forms a continuous, water-tight seal. (F16.1, F16.2 and F16.3)

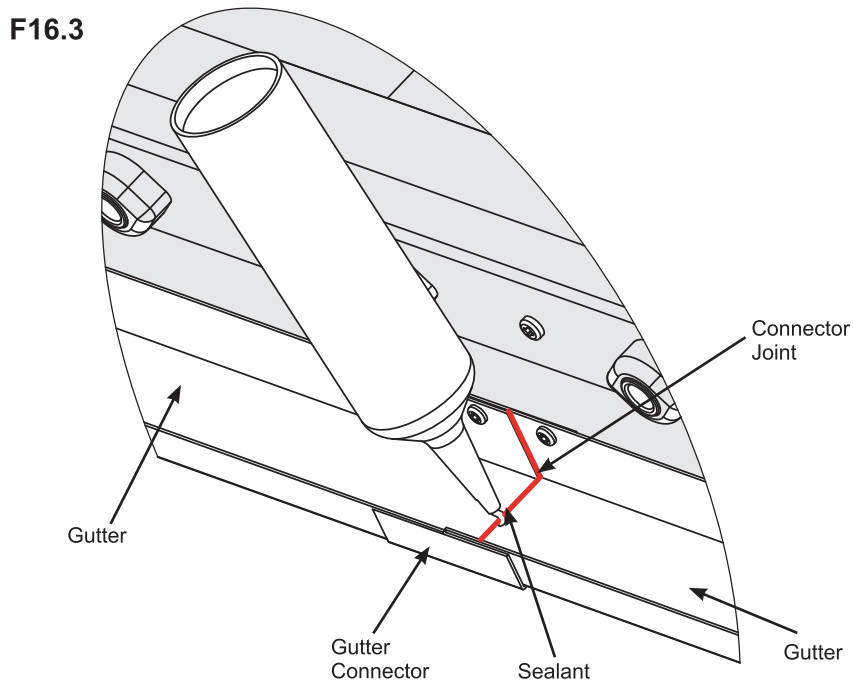
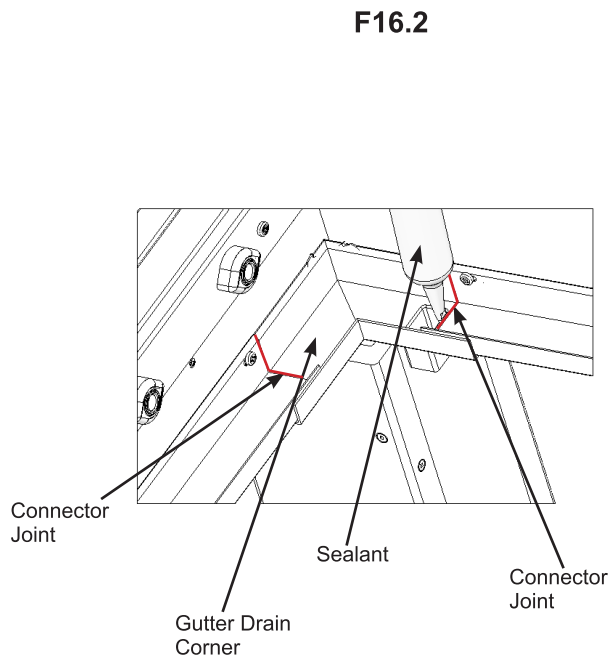
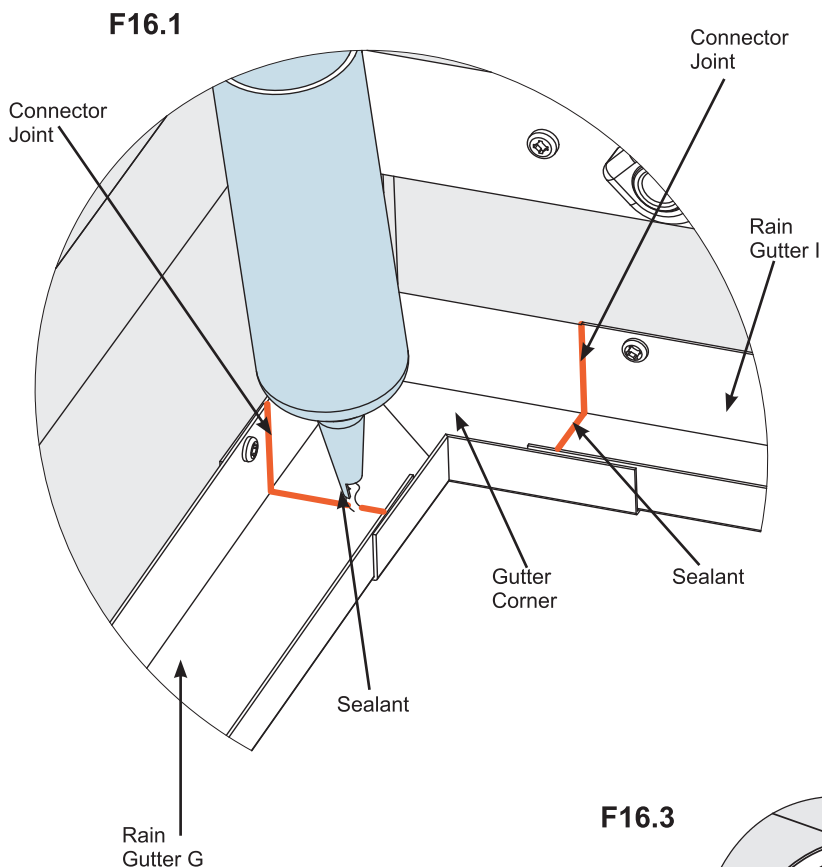

**Note:** All surfaces to be clean, dry, dust and grease free before application with temperatures above 5°C (41°F), no warmer than 35°C (95°F).

- Apply sealant in small beads and smooth as required.
- Clean excess with a cloth or paper towel before it skins over.
- Always wear safety glasses and rubber gloves when using product.

**See page 6 for Warning and First Aid Information.**

## Components

Sealant

# Step 16: Apply Sealant Part 2



**B:** In the seam of the Mid Beam Assembly apply a small evenly distributed bead of sealant and smooth out so it forms a continuous, water-tight seal. (F16.4)

**C:** Along the tops of the Rain Gutters on both Short Beam Assemblies, both Long Beam Assemblies and each side of the Middle Beam, including the tops of the Gutter Corners and Gutter Drain Corners, apply a small evenly distributed bead of sealant, smoothing the sealant so it gets into the joints. (F16.5)

**F16.4**

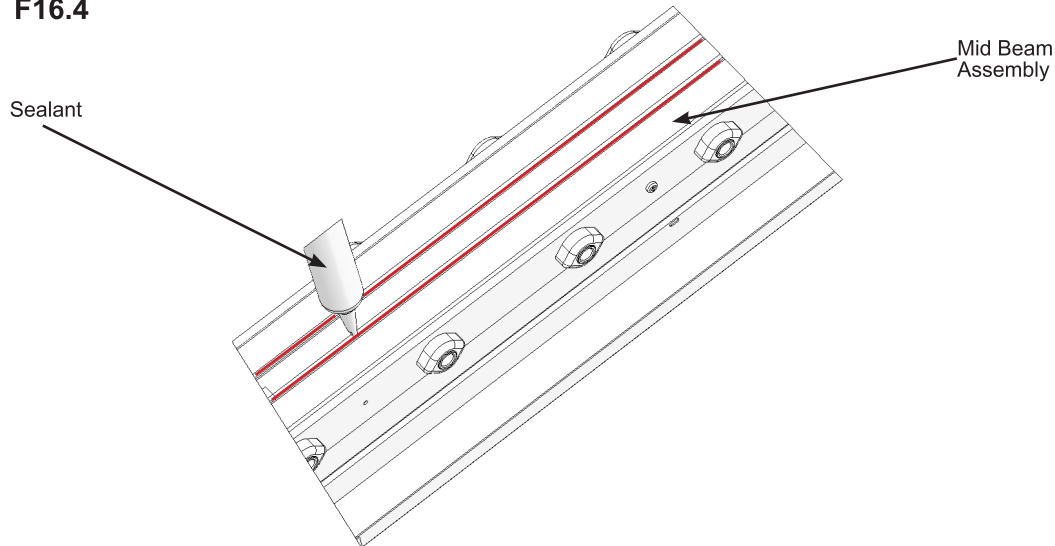

**Note:** All surfaces to be clean, dry, dust and grease free before application with temperatures above 5°C (41°F), no warmer than 35°C (95°F).

- Apply sealant in small beads and smooth as required.
- Clean excess with a cloth or paper towel before it skins over.
- Always wear safety glasses and rubber gloves when using product.

**See page 6 for Warning and First Aid Information.**

**F16.5**

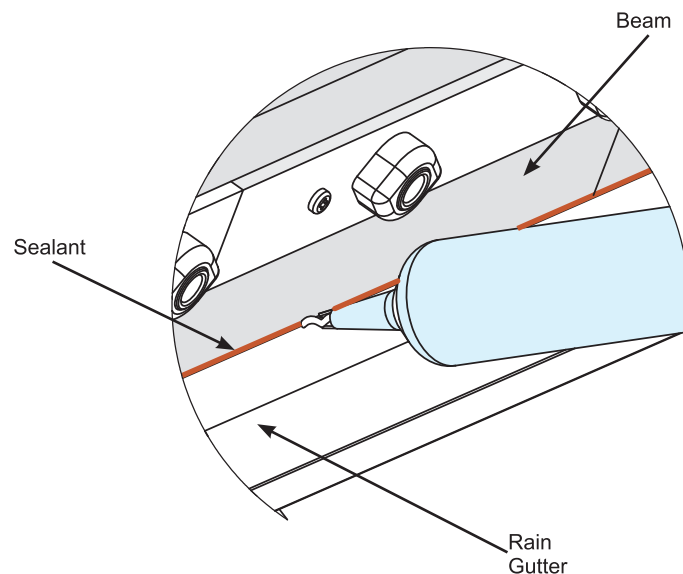

## Components

Sealant

# Step 17: Attach Downspout

## Part 1



**A:** On the post with Gutter Drain Corner slide Downspout 1935 onto the Gutter Drain Corner. (F17.1 and F17.2)

**B:** Attach the Downspout Bottom Elbow to the bottom of Downspout 1935 then attach Downspout 165 to Downspout Bottom Elbow. (F17.1 and F17.3)

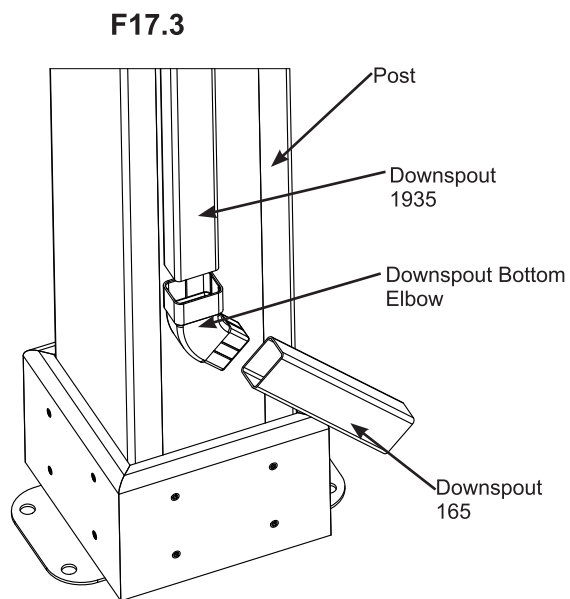
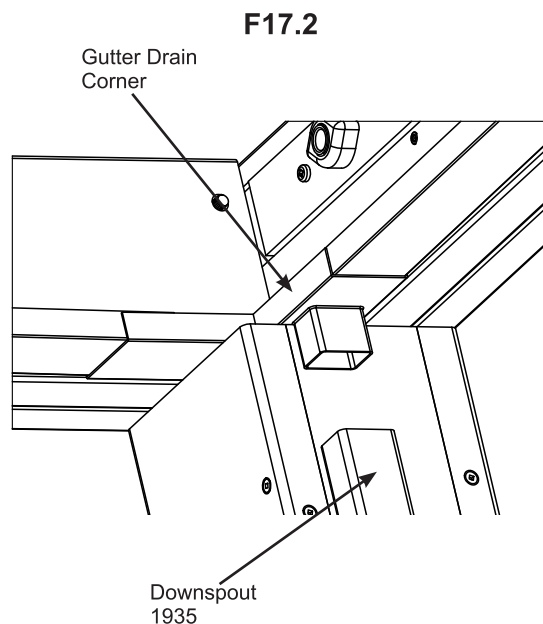
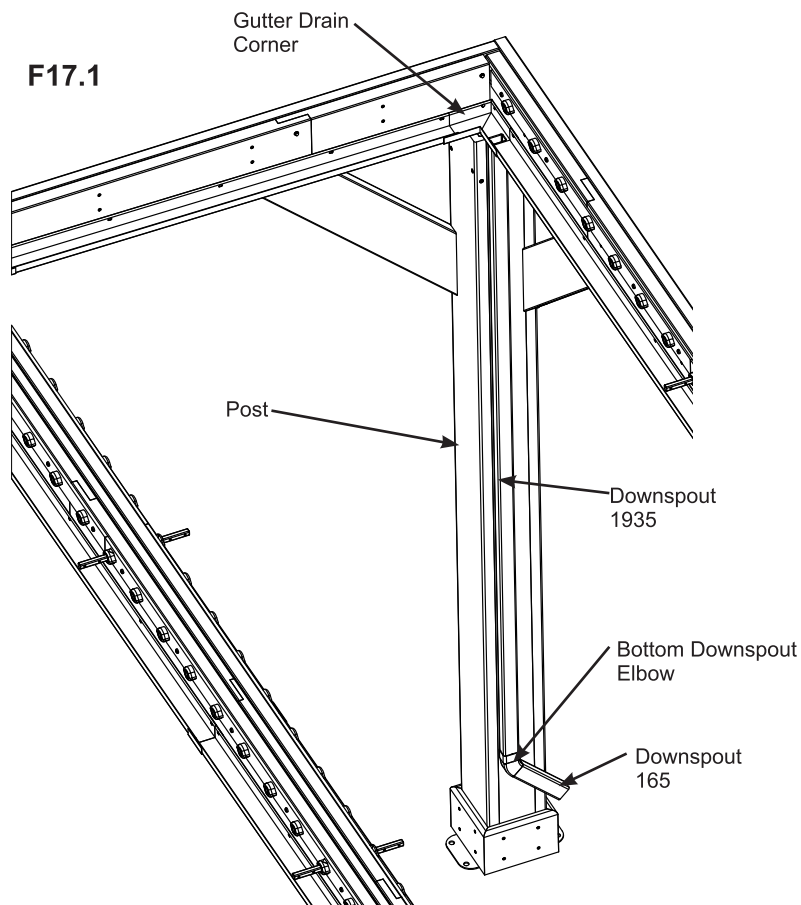

### Components

2 x Downspout 1935  
2 x Downspout Bottom Elbow  
2 x Downspout 165

# Step 17: Attach Downspout



## Part 2

**C:** Make sure Downspout 1935 is tight to bottom of Gutter Drain Corner and attach Downspout Straps to the top, middle and bottom of Downspout 1935 with two #8 x 1 Pan Screws per strap. (F17.4 and F17.5)

**D:** Repeats Steps A - C on the other Gutter Corner Drain.

F17.4

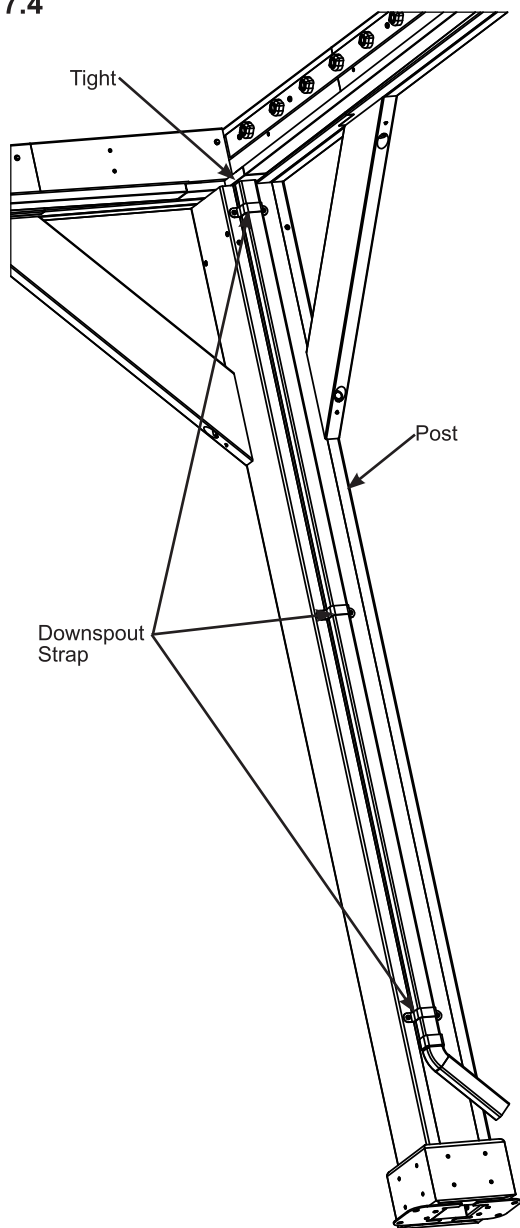

F17.5

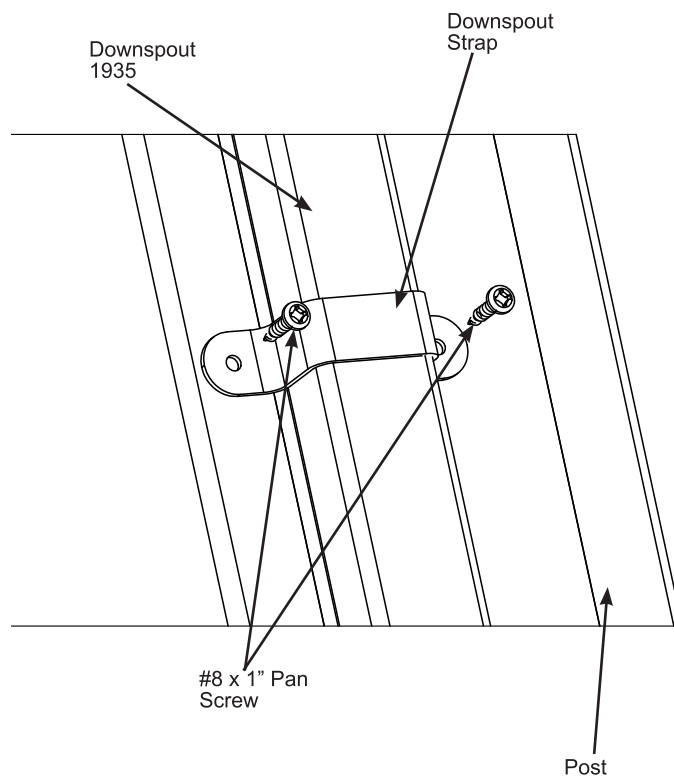

**Components**  
6 x Downspout Strap

**Hardware**  
12 x #8 x 1" Pan Screw

# Step 18: Louver Assemblies Part 1

**A:** On six Louvers attach one Louver End Plate to each end with two #8 x 1" Pan Screws per plate. Use a Standard Pin to help line up proper placement. Remove Standard Pin when Louver End Plate is secure. (F18.1, F18.2 and F18.3)

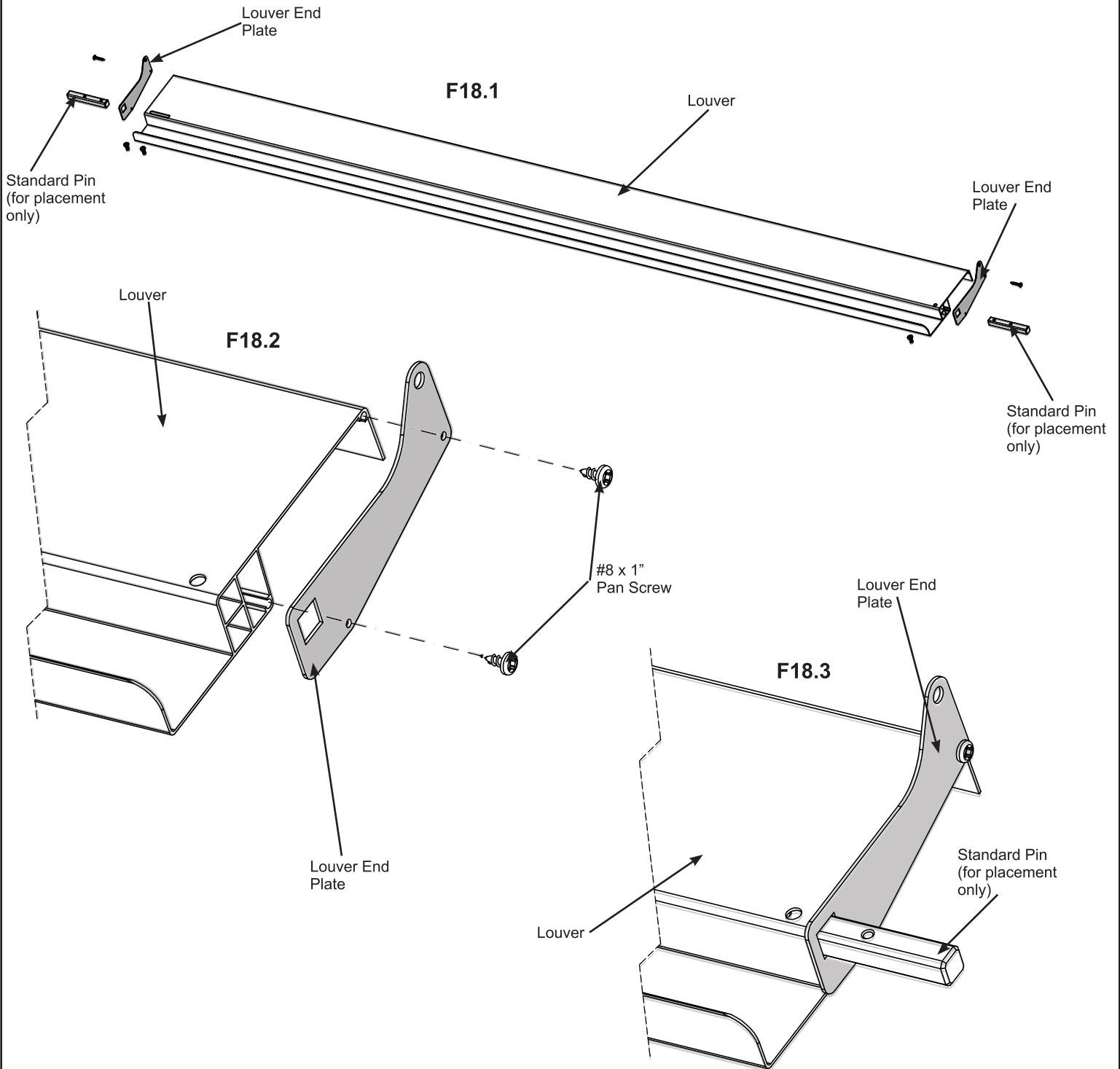

### Components

6 x Louver  
12 x Louver End Plate

### Hardware

24 x #8 x 1" Pan Screw



# Step 18: Louver Assemblies

## Part 2

**B:** On the remaining 40 Louvers place one Standard Pin in the square slot at each end. Push pins all the way in to the second bolt hole. On the side of the Louver with the single bolt hole, tightly attach to pin with one 1/4 x 1/2" Pan Bolt. On the side of the Louver with the bolt slot, loosely attach to pin with one 1/4 x 1/2" Pan Bolt. Notice which end of Standard Pin is inserted in Louvers. (F18.4, F18.5 and F18.6)

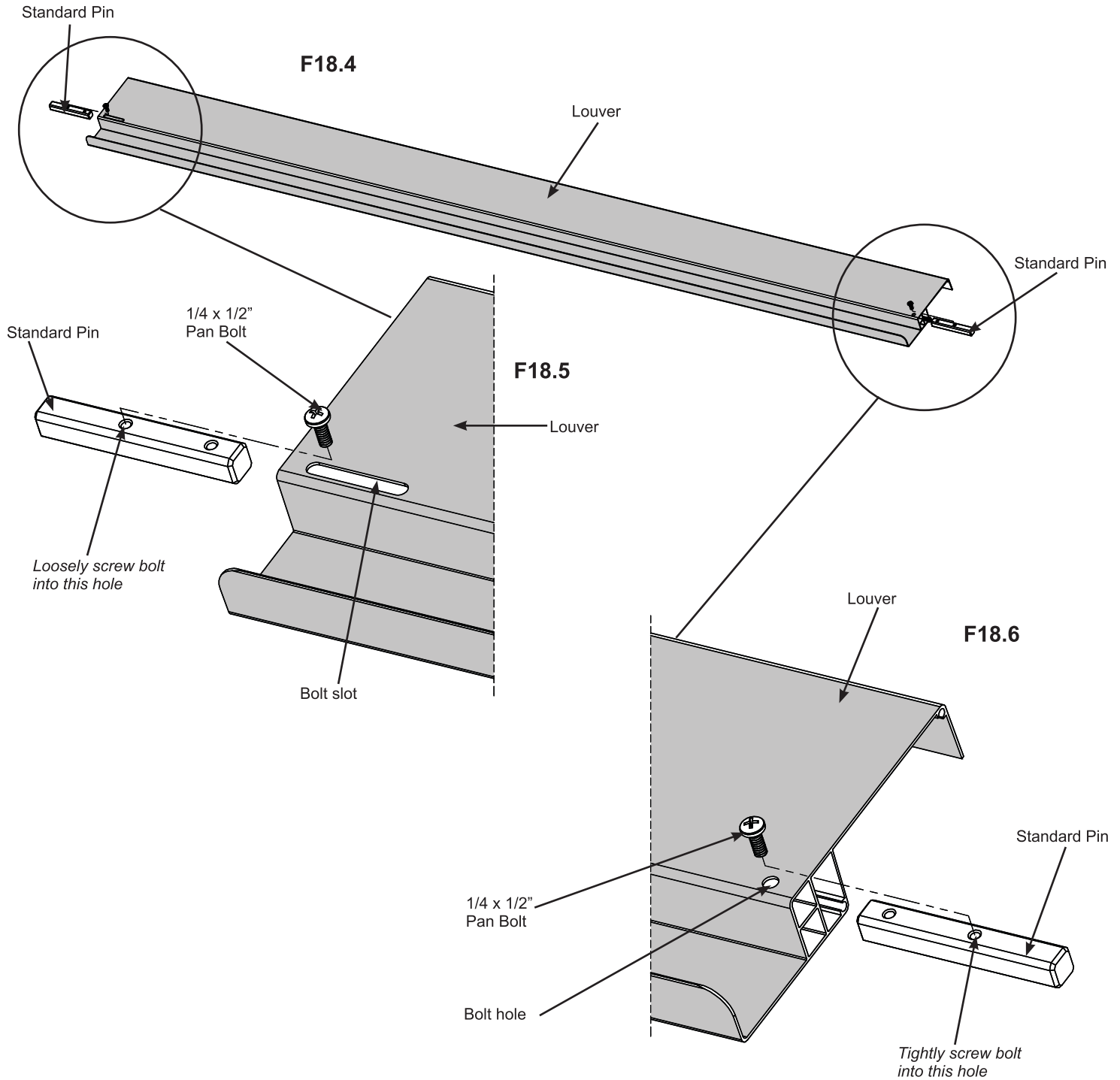

### Components

40 x Louver  
80 x Standard Pin

### Hardware

80 x 1/4 x 1/2" Pan Bolt

# Step 18: Louver Assemblies

## Part 3

**C:** Place one Louver End Plate at each end of the Louvers, fitting over the pins then attach with two #8 x 1" Pan Screws per plate. (F18.7 and F18.8)

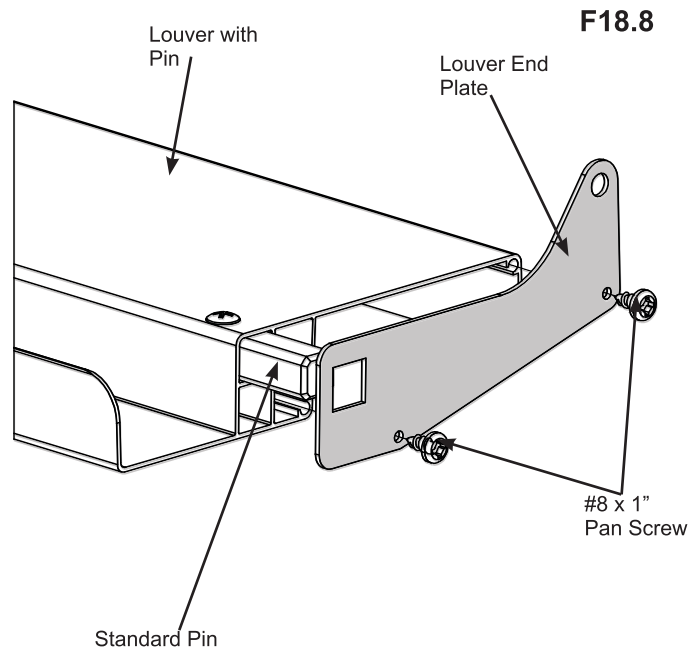
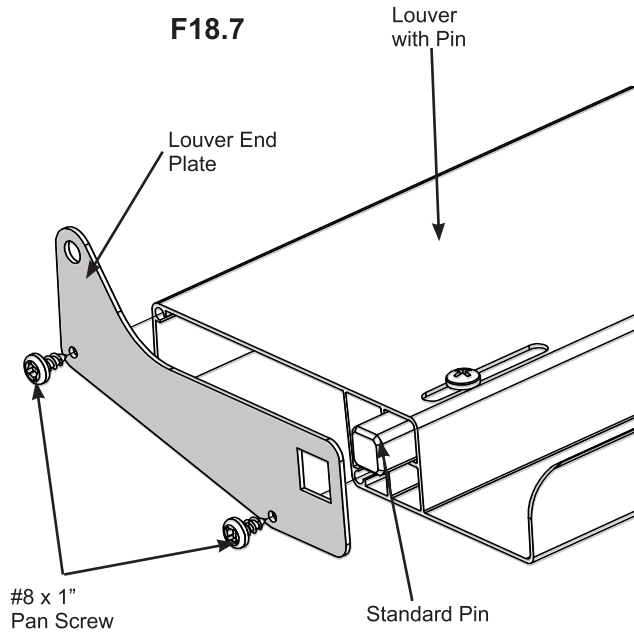

### Components

80 x Louver End Plate

### Hardware

160 x #8 x 1" Pan Screw

# Step 18: Louver Assemblies

## Part 4

**D:** On each Louver End Plate loosely attach one 1/4 x 5/8" Pan Bolt (with nylon washer and 1/4" lock nut) per plate. (F18.9 and F18.10)

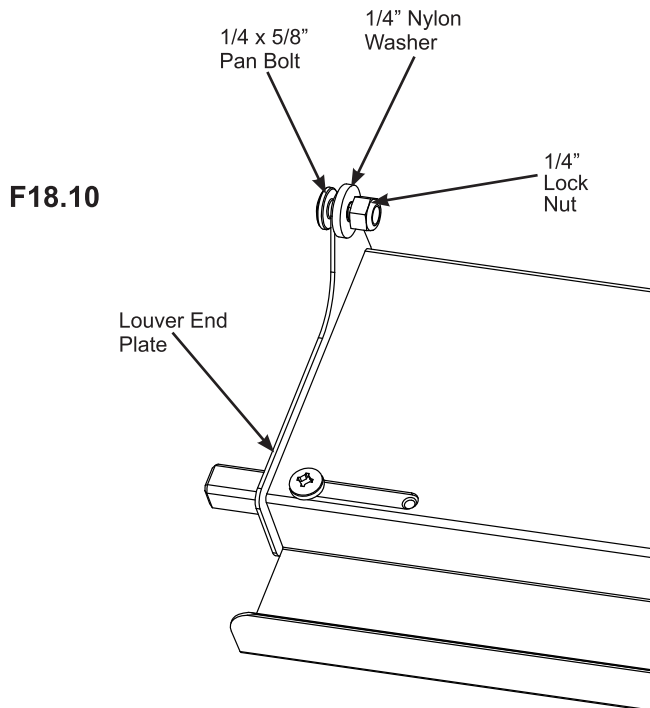
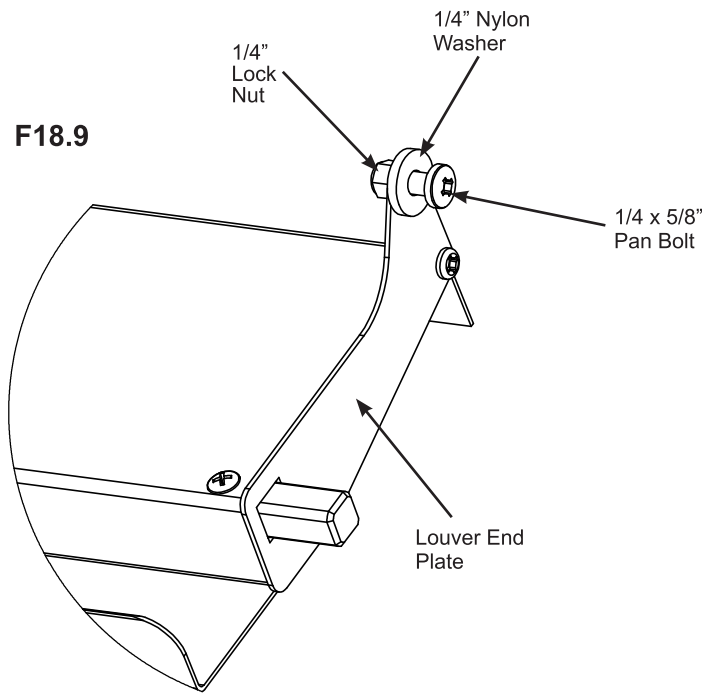

### **Hardware**

92 x 1/4 x 5/8" Pan Bolt  
(1/4" nylon washer, 1/4" lock nut)

# Step 19: Attach Louver Assemblies Part 1



**A:** Starting at the Crank End Side, with one Louver with pins, bolt at the top. Move the pin in the bolt slot end all the way into the Louver. Insert fully tightened pin at bolt hole end into first bushing on the Long Beam Assembly. (F19.1, F19.2 and F19.3)

**B:** Slide the pin on the bolt slot end out of the Louver and into the first bushing on the Mid Beam Assembly and tighten bolt. Attach one 1/4 x 1/2" Pan Bolt into Standard Pin through bolt slot. Both bolts should be tight. (F19.1, F19.4 and F19.5)

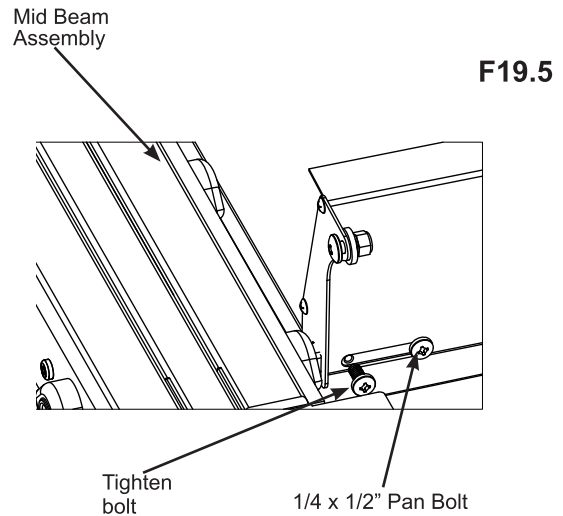
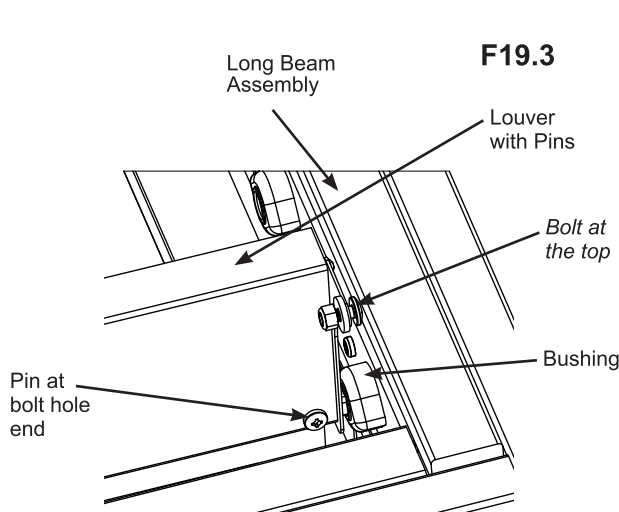
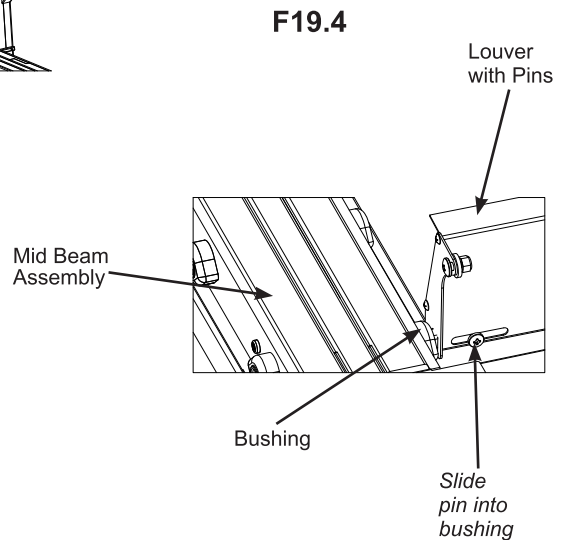
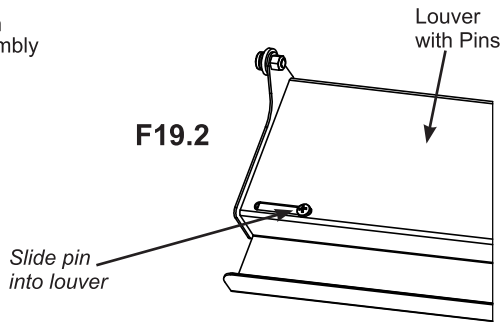
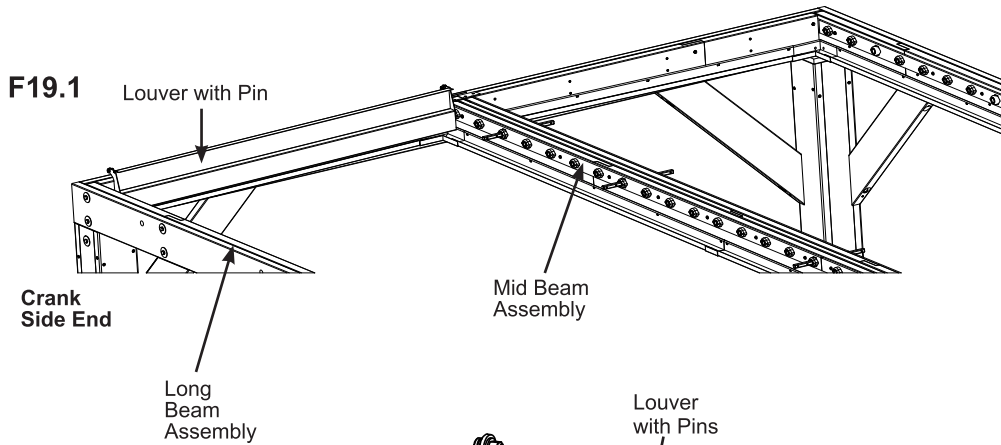

## Hardware

2 x 1/4 x 1/2" Pan Bolt

# Step 19: Attach Louver Assemblies Part 2



**C:** Repeat Steps A - B to install two Louvers with pins in the middle and last bushing (next to the Short Beam Assembly) (F19.6, F19.7, F19.8, F19.9 and F19.10)

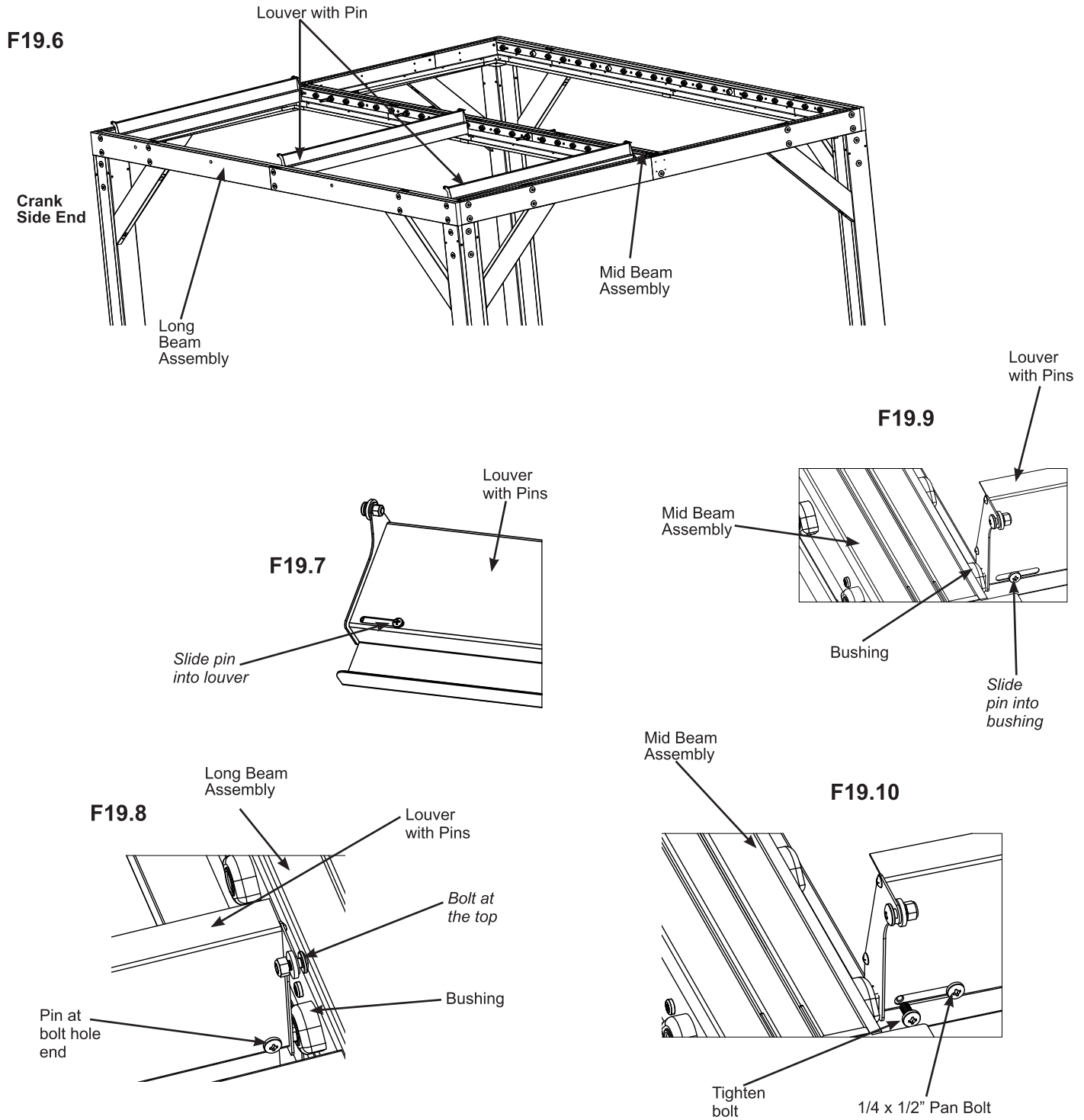

**Hardware**

4 x 1/4 x 1/2" Pan Bolt

# Step 19: Attach Louver Assemblies Part 3

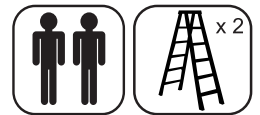

**D:** At the third bushing place one Louver without pins so the end with the bolt slot fits over the pin previously installed on the Mid Beam Assembly. Attach with two 1/4 x 1/2" Pan Bolts. (F19.11, F19.12 and F19.13)

**E:** Through the outside of the Long Beam Assembly insert one Drive Pin through the bushing with the arrow on top and into the Louver without pins. Attach with one 1/4 x 1/2" Pan Bolt into second hole of Drive Pin. (F19.11, F19.14 and F19.15)

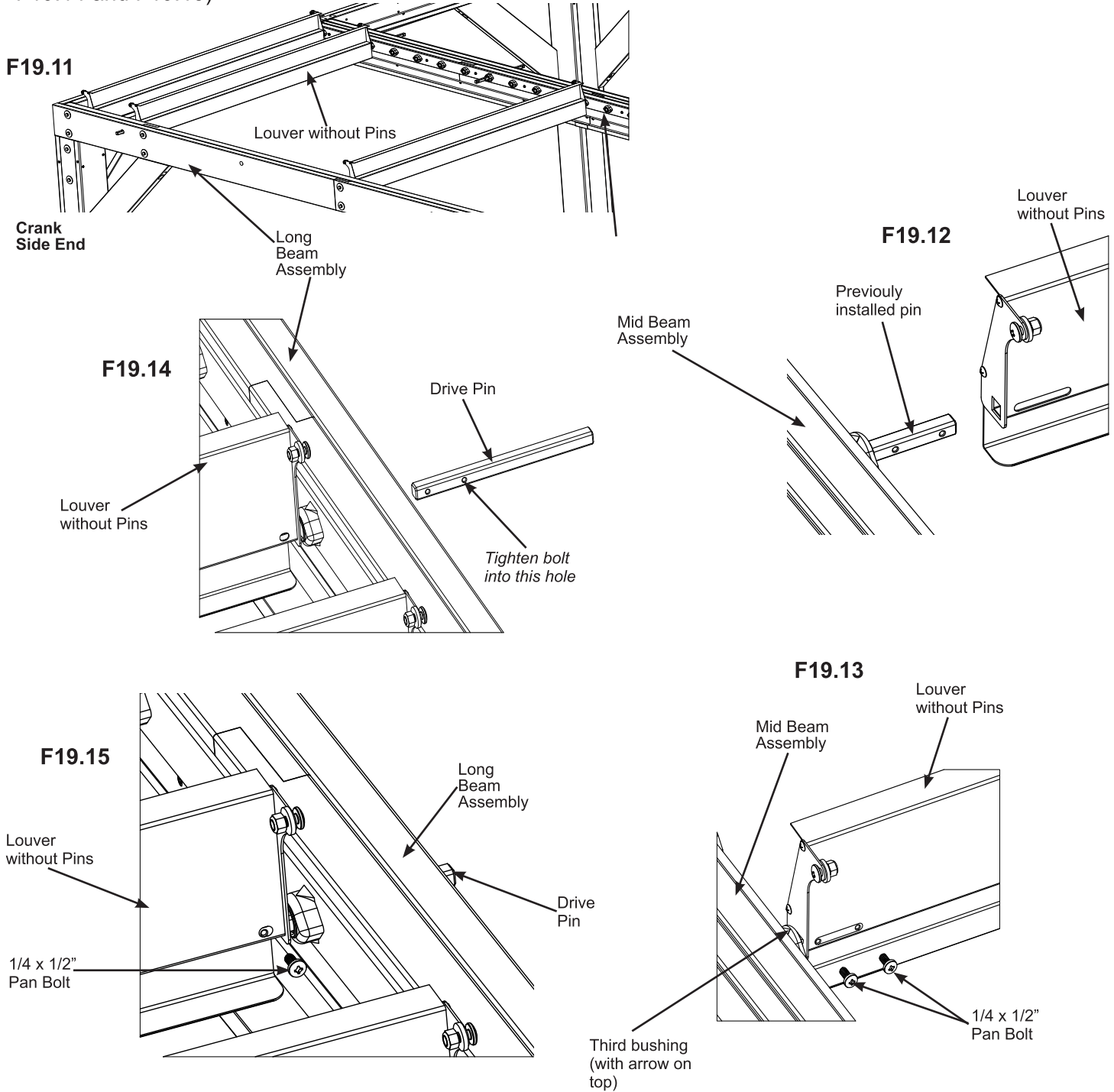

### Components

2 x Drive Pin

### Hardware

6 x 1/4 x 1/2" Pan Bolt

# Step 19: Attach Louver Assemblies Part 4

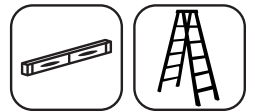

**E:** Place one Gear Box over the Drive Pin, make sure it is level then attach to Long Beam Assembly with two 1/4 x 1-15/16" Lag Screws (with 5/16" flat washer - gray) and two #8 x 3-1/2" Wood Screws. (F19.16 and F19.17)

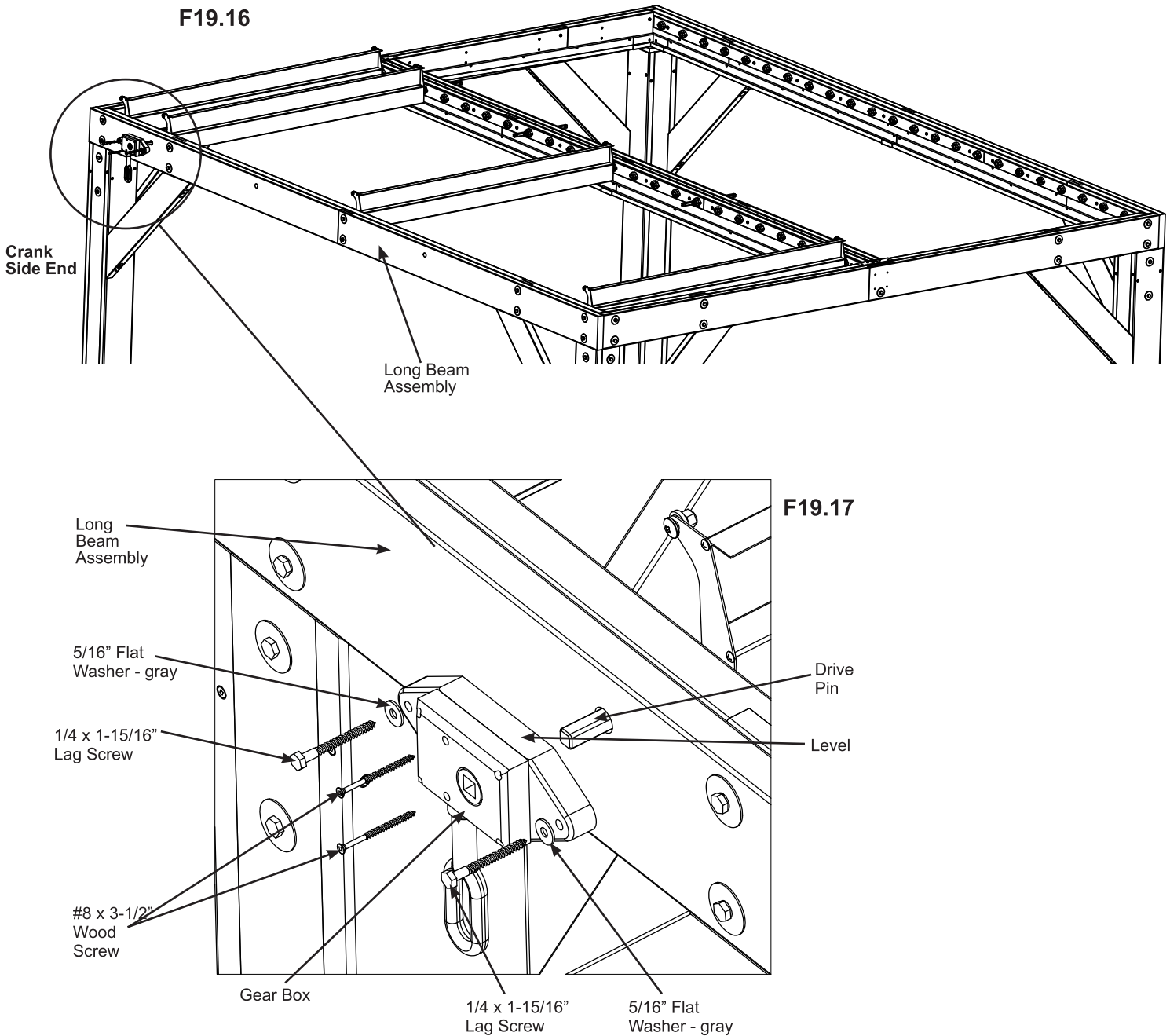

### Components

2 x Gear Box

### Hardware

4 x 1/4 x 1-15/16" Lag Screw (5/16" flat washer - gray)  
4 x #8 x 3-1/2" Wood Screw

# Step 19: Attach Louver Assemblies Part 5

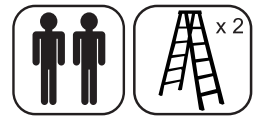

**F:** Place two Louvers without pins so the end with the bolt slot fits over the pins previously installed on the Mid Beam Assembly. Attach with two 1/4 x 1/2" Pan Bolts. (F19.18 and F19.19)

**G:** Through the outside of the Long Beam Assembly insert one Long Pin, per louver, through the bushing and into the Louver without pins. Attach with one 1/4 x 1/2" Pan Bolt. (F19.18 and F19.20)

**F19.18**

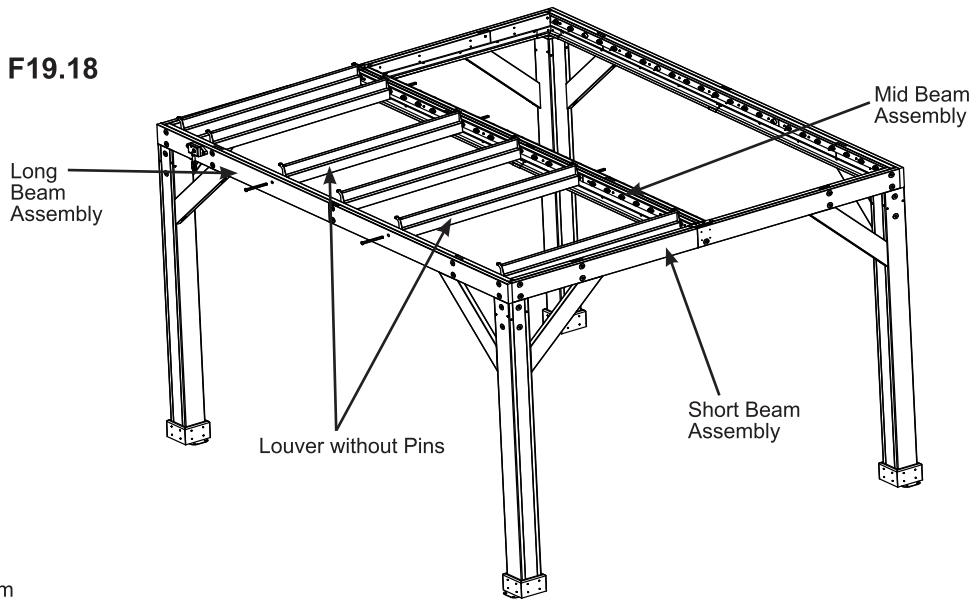

**F19.19**

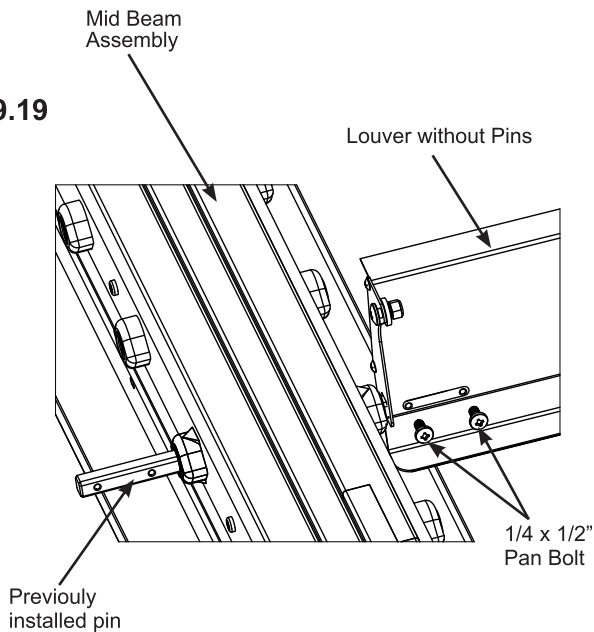

**F19.20**

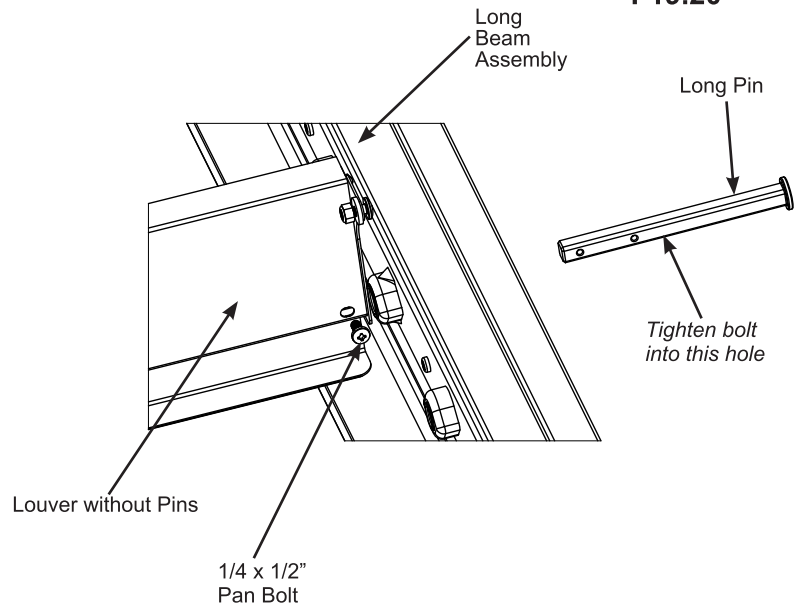

**Components**

4 x Long Pin

**Hardware**

12 x 1/4 x 1/2" Pan Bolt



# Step 19: Attach Louver Assemblies Part 6



**H:** Using the bolts, nylon washers and lock nuts previously attached to the tops of the Louver End Plates, connect one Louver Link to each end of the first three louvers. Lock nuts to be flush to end of bolt. The flange on the Louver Link to point away from Louvers. (F19.21, F19.22 and F19.23)

**I:** At the end of the Louver Link connect a second Louver Link to each end of the louver installed in Step C using the bolts, nylon washers and lock nuts previously attached to the tops of the Louver End Plates. Connect remaining louvers to Louver Links. (F19.18, F19.19 and F19.20)

*Crank Handle can be attached at this time.*

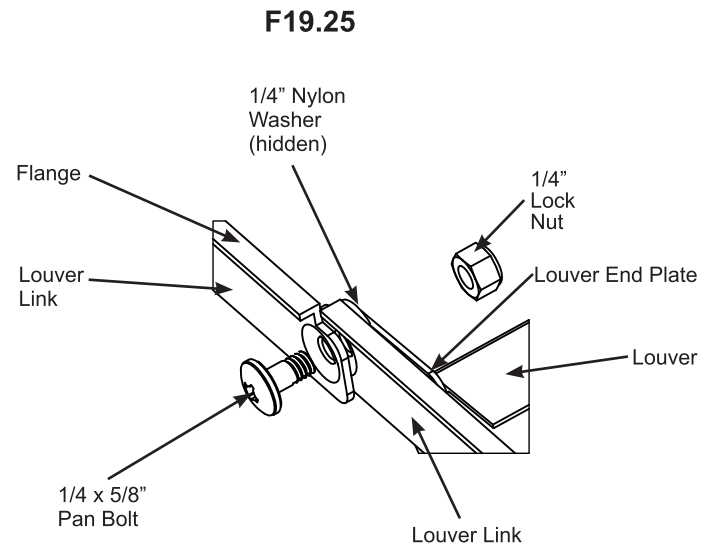
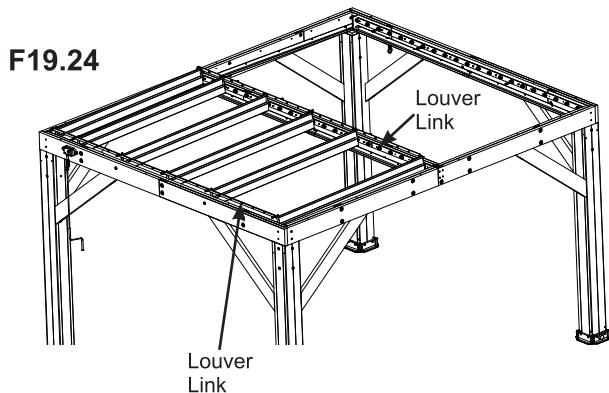
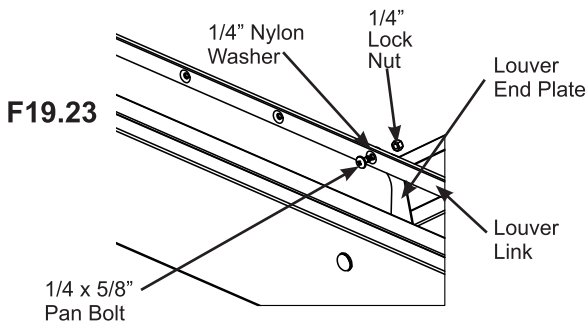
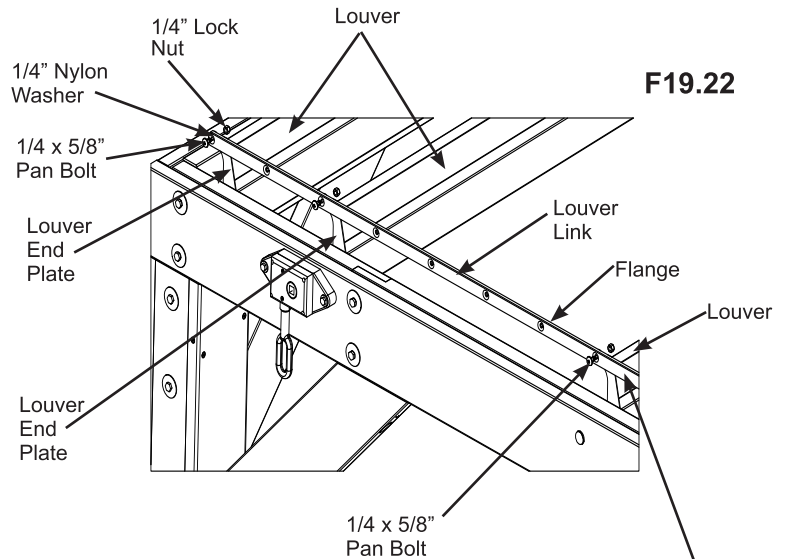
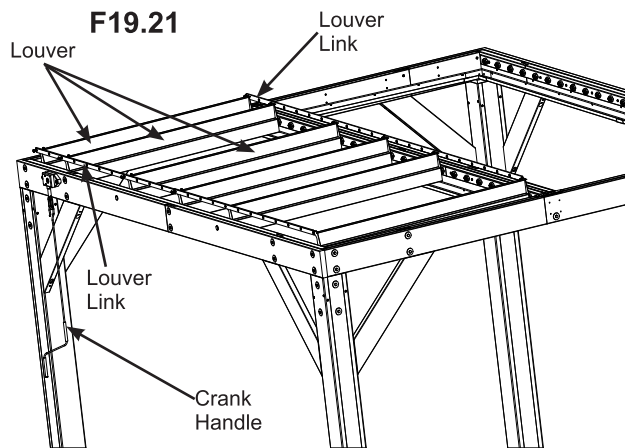

## Components

8 x Louver Link

# Step 19: Attach Louver Assemblies Part 7

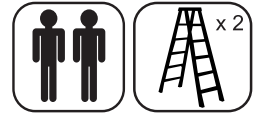

**J:** Attach 17 remaining Louvers with pins to the beams on this side of the assembly as described for the first in Steps A and B. (page 50)

**K:** Connect remaining louvers to Louver Links with previously attached bolts, nylon washer and lock nuts. (F19.26, F19.27 and F19.28)

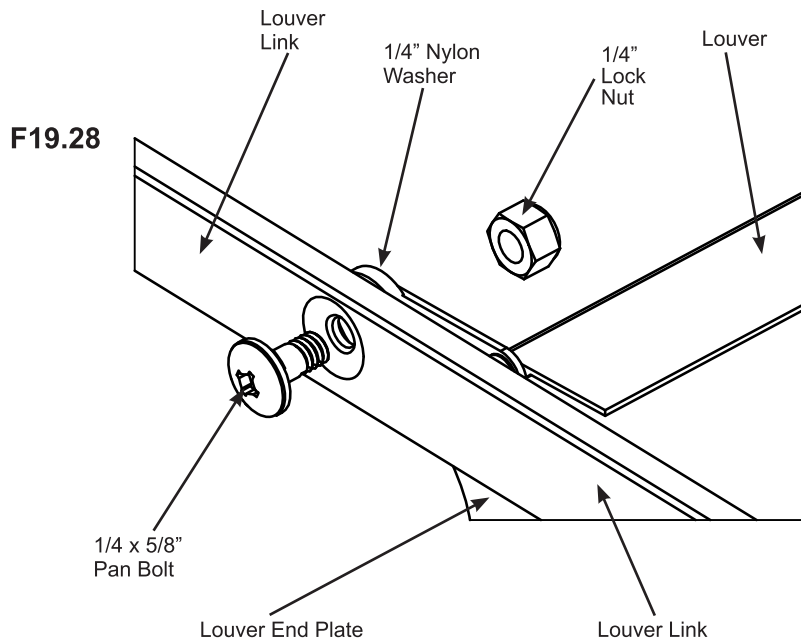
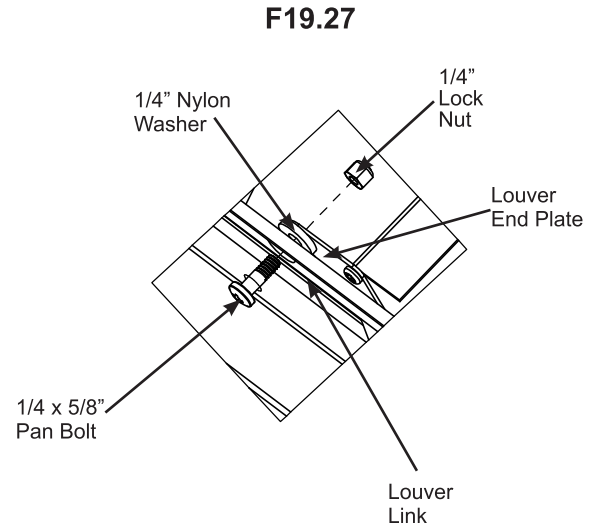
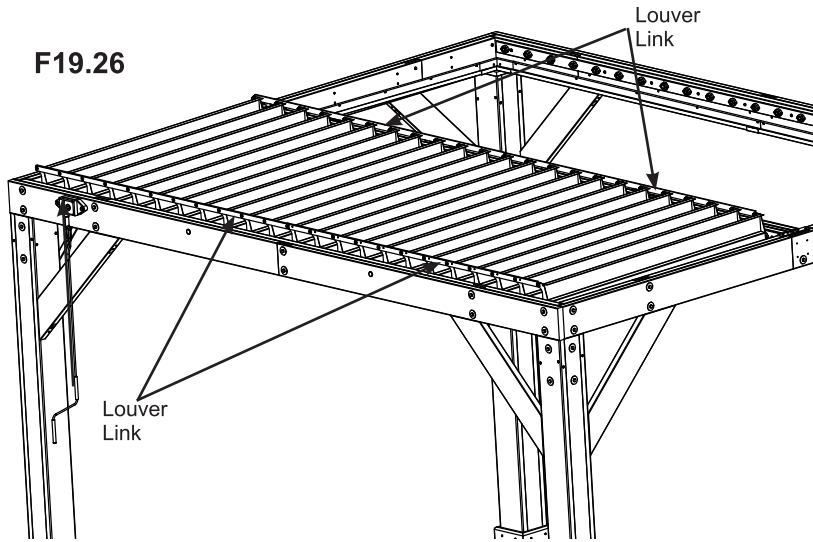

## Hardware

34 x 1/4x 1/2" Pan Bolt

## Step 20: Attach Louver Assemblies - Second Side

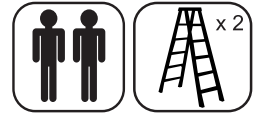

**A:** Repeat Step 19 (A - K) for the second side of the assembly.

**B:** When connecting the Louvers with and without pins for this side make sure end with bolt slot (2 bolts) is attached to the Long Beam Assembly and the end with the single bolt hole is attached to the Mid Beam Assembly. If they are not attached in this order they will not turn properly. (F20.1, F20.2 and F20.3)

**F20.2**

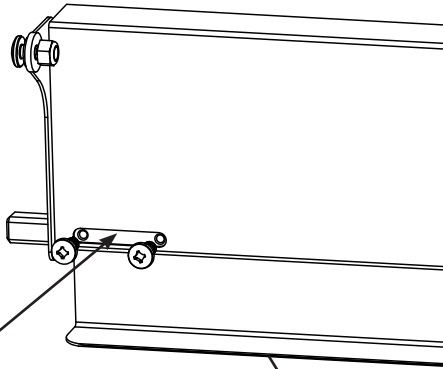

**F20.3**

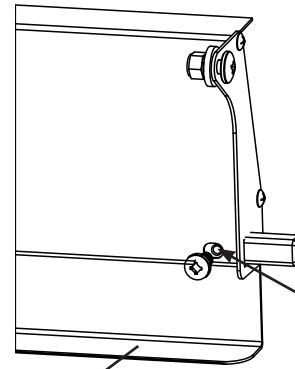

Bolt hole

Bolt slot

**F20.1**

Long  
Beam  
Assembly

Mid Beam  
Assembly

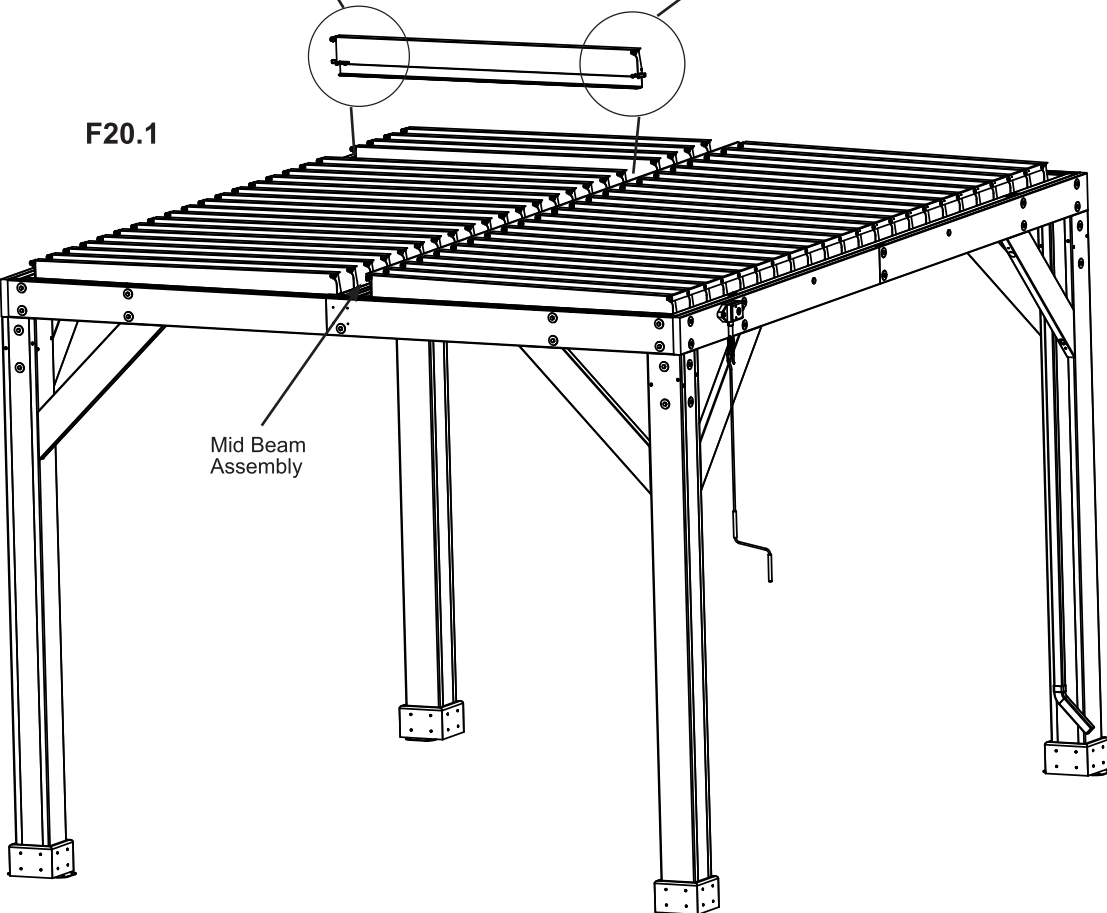

# Step 21: Attach ID Plaque



**A:** Attach Gazebo ID Plaque to a prominent location on your gazebo with two #10 x 1-1/4" Pan Screws. This provides warnings concerning safety and important contact information. A tracking number is provided to allow you to get critical information or order replacement parts for this specific model. (F21.1 and F21.2)

**F21.1**

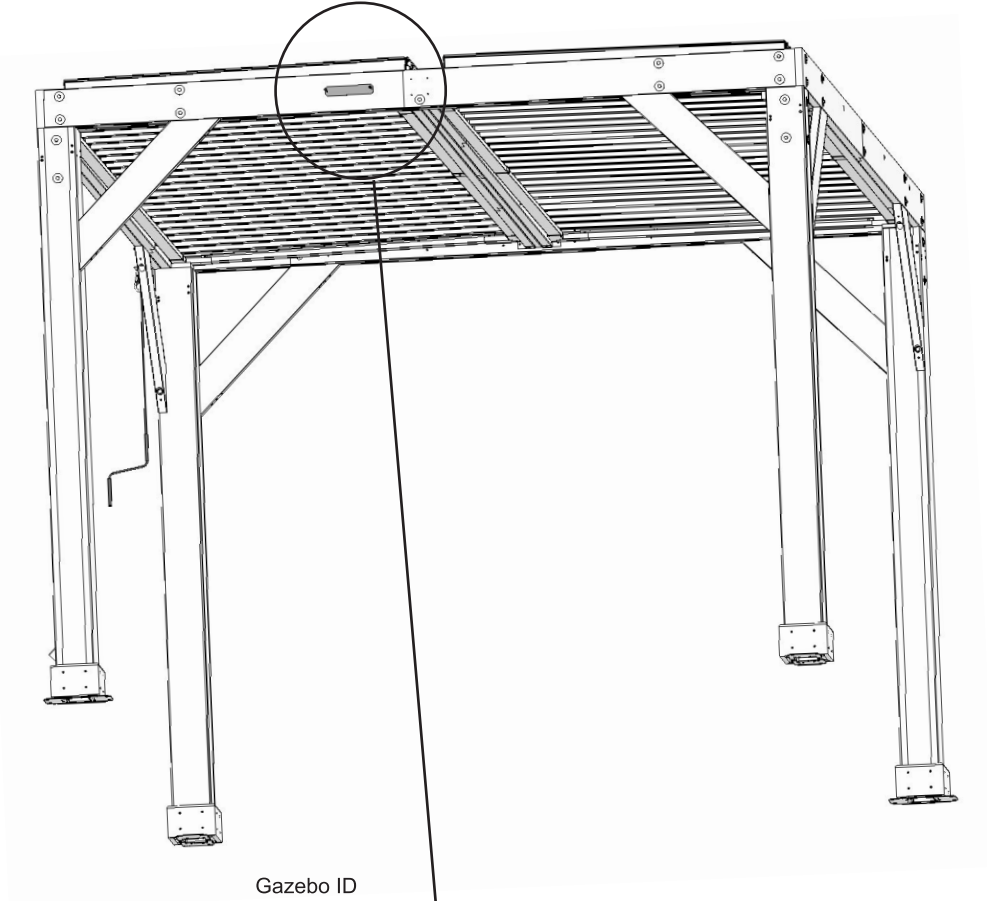

**F21.2**

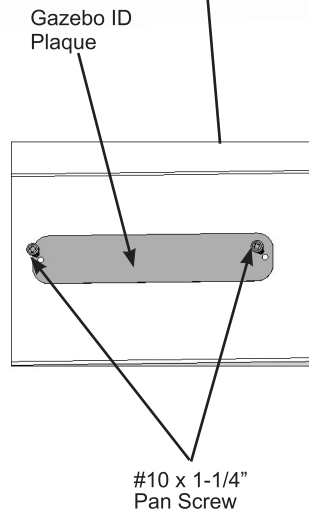

**Components:**

1 x Gazebo ID Plaque

**Hardware**

2 x #10 x 1-1/4" Pan Screw

## Step 22: Gear Box Lockout and Winter Maintenance



**A:** To lock the Gear Box remove the Crank Handle then attach Lock Out to each Gear Box using the Quick Link to secure in place. (F22.1 and F22.2)

**IMPORTANT!** When preparing for high winds and/or winter conditions, turn the louvers to the open position (upright) then attach the Lock Out and Quick Link. This will prevent the structure from blowing over due to high winds and the louvers from breaking due to snow and ice loads. (F22.1 and F22.2)

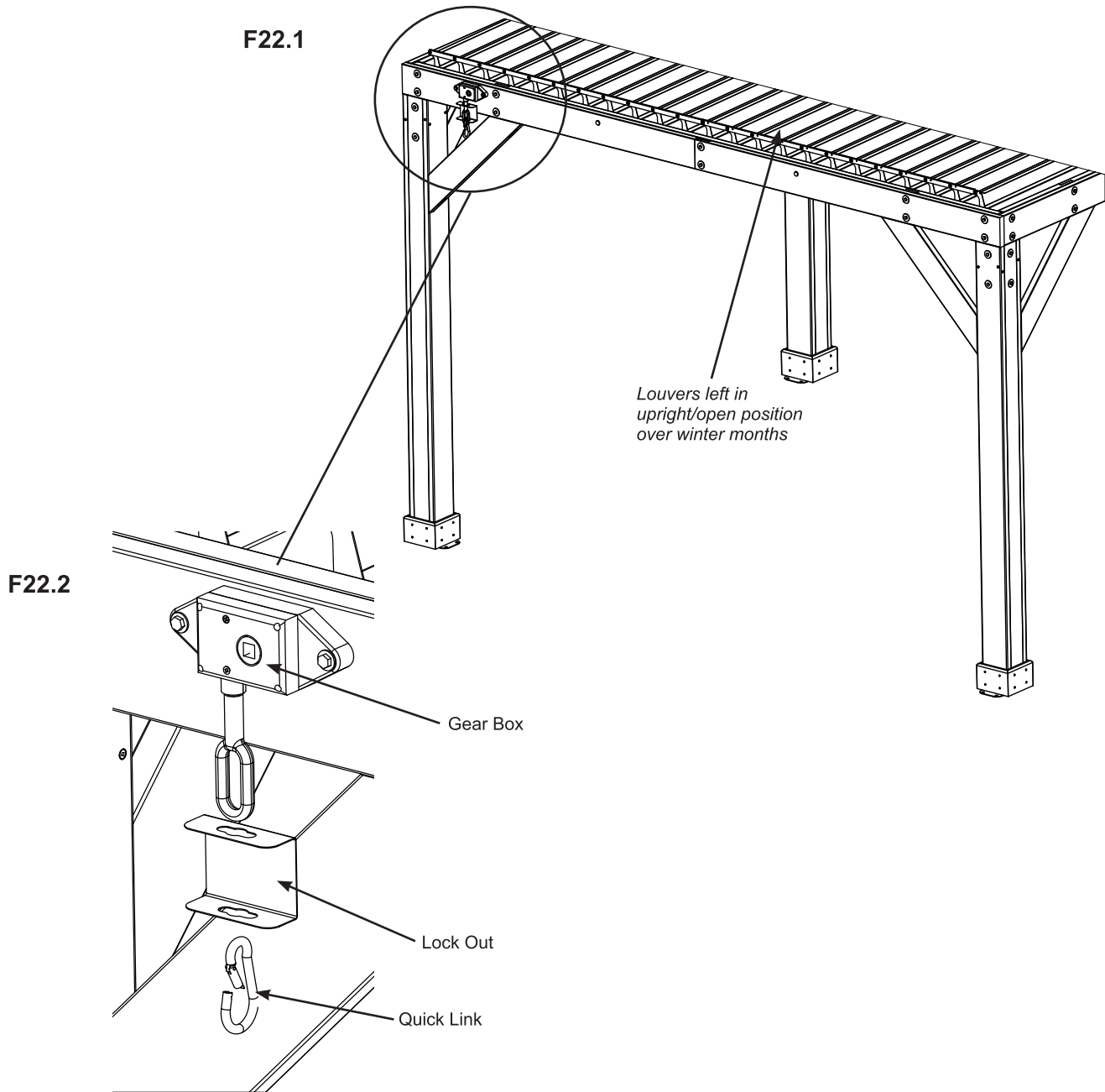

### Components:

- 2 x Lock Out
- 2 x Quick Link







## Customer Registration Card - Tarjeta de Registro del Cliente - Carte d'inscription du client

First Name - Primer Nombre - Prénom	Initial - Inicial - Initiale	Last Name - Apellido - Nom de famille

Street - Calle - Rue	PO Box - Casilla postal - Boîte postale	Apt. No. - App.

City - Ciudad - Ville	State/Province - Estado/Provincia - État/Province

ZIP/Postal Code - Código Postal - ZIP/Code postal	Country - País - Pays

E-mail Address - Dirección de E-mail - Adresse courriel	Telephone Number - No. de Teléfono - N° de téléphone

Model Name - Nombre del Modelo - Nom du modèle	Model Number (from front cover) - Número de Modelo (de la portada) - N° du modèle (page de couverture)

Date of Purchase - Fecha de Compra - Date d'achat (mm/dd/yyyy) (mm/dd/aaaa) (mm/jj/aaaa)	Place of Purchase - Comprado a - Lieu d'achat

Comments - Comentarios - Commentaires:

### Mail To - Enviar por Correo a - Envoyer par courrier à:

Yardistry  
375 Sligo Road West, PO Box 10  
Mount Forest, Ontario, Canada, N0G 2L0  
Attention: Consumer Relations  
Atención a: Servicio de Atención al Cliente  
À l'attention de: Service à la clientèle

### Online Registration - Registro online - Enregistrement en ligne:

[www.yardistrystructures.com/warranty](http://www.yardistrystructures.com/warranty)

Hours/ Heures/ Horas: 8:30 am - 5:00 pm EST  
(excl. holidays/ hors jours fériés/ excepto los días festivos)

English and French Spoken / Anglais et français parlés / Inglés y francés hablado

Yardistry would like to say "Thank you" for your time and feedback.

Yardistry quiere "Agradecerle" por su tiempo y su opinión.

Yardistry aimerait vous remercier d'avoir pris le temps de répondre au sondage.