

Step 9: Join Swing and Slide Assemblies Part 1

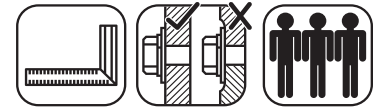

A: With at least two helpers lift the Slide Wall Assembly and Swing Wall Assembly so the (072) Narrow Panel Back and (073) Narrow Front Panel meet with (083) Wall Panel Back and (082) Panel Front Wall and are tight together as shown in fig. 9.1.

B: Make sure the assembly is square then on the inside of the assembly, tight to (071) Nest End Panel and flush to the bottom of the panels attach 1 (091) Floor Joist to (072) Narrow Panel Back and (083) Wall Panel Back using 4 (S7) #12 x 2" Pan Screws. Attach a second (091) Floor Joist to (073) Narrow Front Panel and (082) Panel Front Wall with 4 (S7) #12 x 2" Pan Screws. (fig. 9.1 and 9.2)

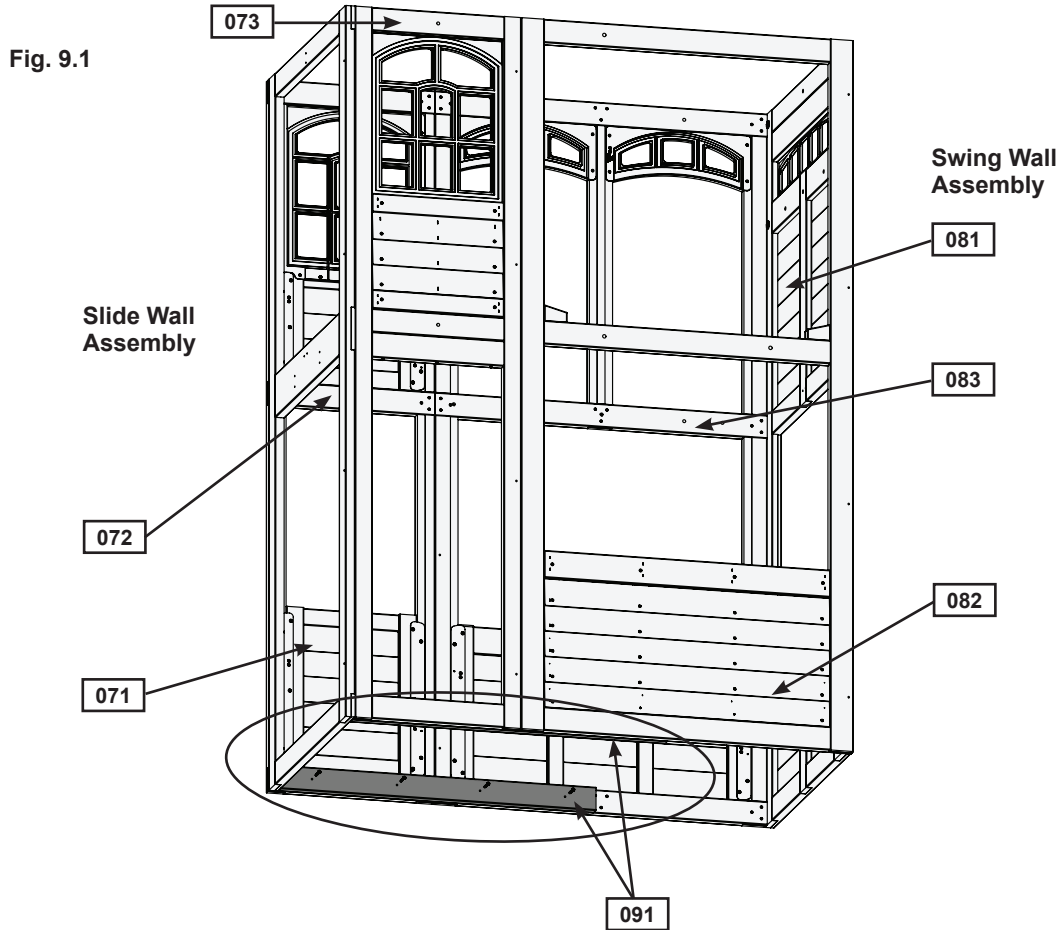
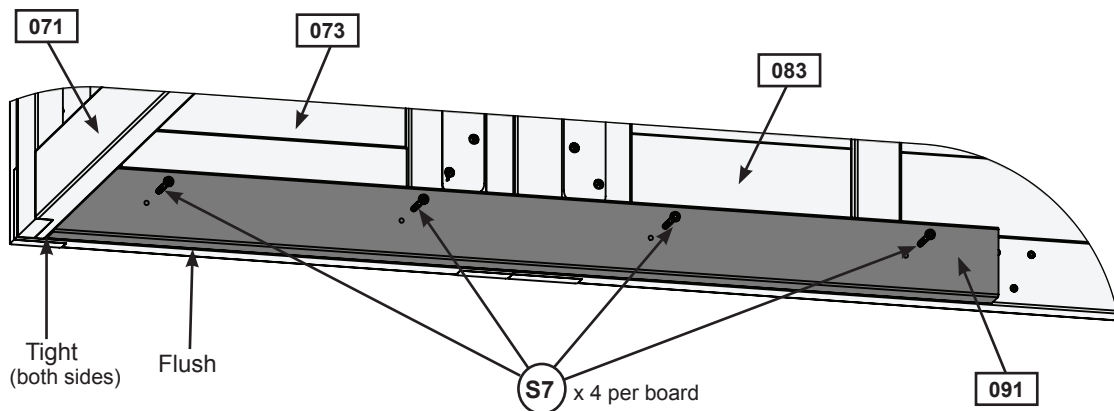

Fig. 9.2



Wood Parts

2 x 091 Floor Joist 1-1/4 x 3 x 40-3/4"

Hardware

8 x S7 #12 x 2" Pan Screw

Step 9: Join Swing and Slide Assemblies

Part 2



Note: It is important to ensure that all t-nuts are installed in the correct locations.

C: Open the Rope Ladder bag and locate the (M8) t-nut. From inside the fort install (M8) t-nut into the Back Wall using the second hole from the left as shown in fig. 9.6.

D: From inside the assembly, install 3 (TN2) 5/16" t-nuts into the Back Wall in the locations shown in fig. 9.4. Place 1 (092) Side Joist so that it's tight to both (071) Nest End Panel and (081) SW Wall Panel, halfway up the assembly and 5/8" below the panel. Attach loosely to (072) Narrow Panel Back and (083) Wall Panel Back with 3 (WB10) 5/16 x 2-5/8" Wafer Bolts (with flat washer and t-nut). Bolts are installed from inside the assembly. Make sure (092) Side Joist is level then attach with 2 (S3) #8 x 2-1/2" Wood Screws and tighten bolts. (Fig. 9.3, 9.4 and 9.5)

E: Repeat Step D to attach 1 (092) Side Joist to (073) Narrow Front Panel and (082) Panel Front Wall. (Fig. 9.3, and 9.4)

Fig. 9.3

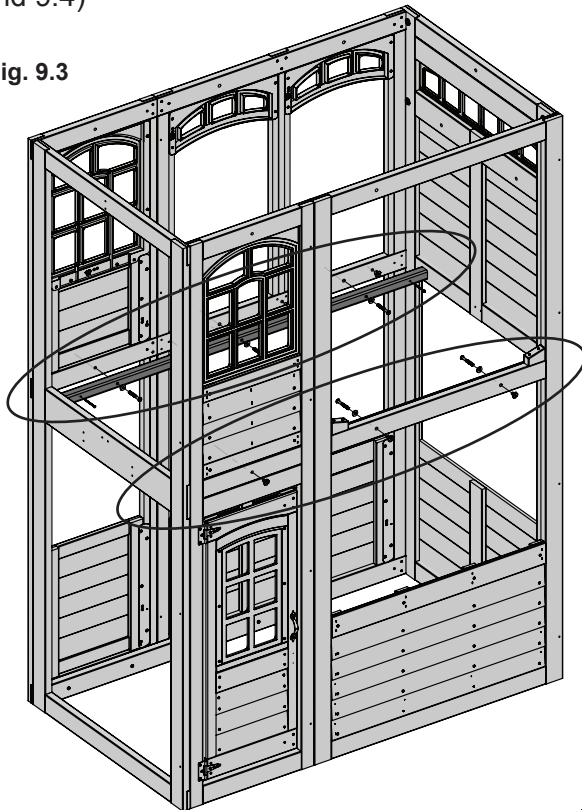

Fig. 9.5

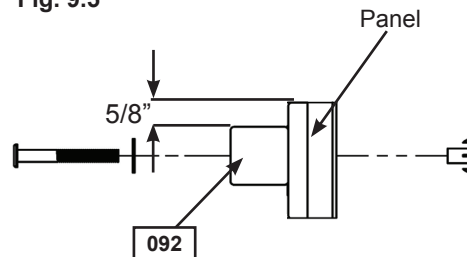

Fig. 9.6

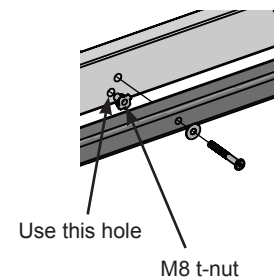
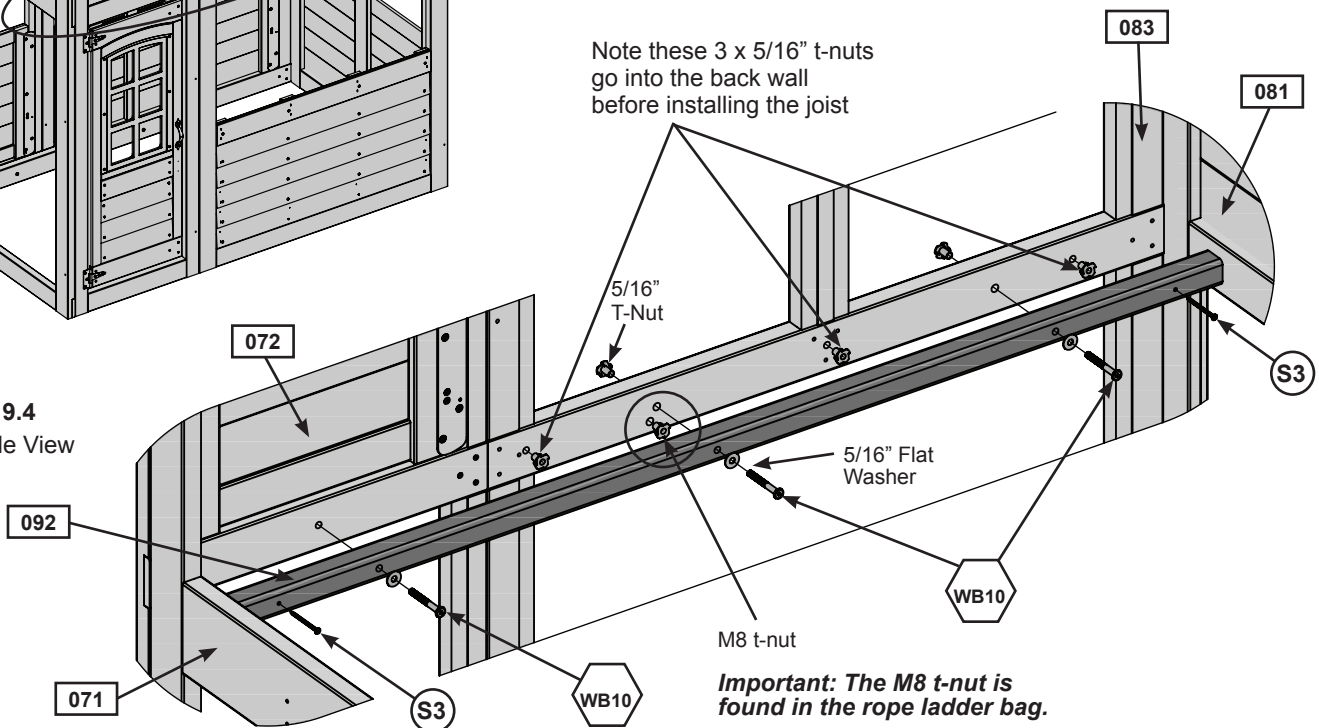

Fig. 9.4
Inside View



Wood Parts

2 x 092 Side Joist 1-1/2 x 1-1/2 x 63"

Hardware

4 x S3 #8 x 2-1/2" Wood Screw

6 x WB10 5/16 x 2-5/8" Wafer Bolt
(5/16" flat washer, 5/16" t-nut)

3 x TN2 5/16" t-nuts

Step 10: Install Joist Assembly

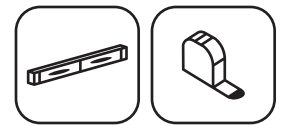

A: From inside the assembly measure 5/8" (15.9mm) down from the top of the Wall Panels and place the joist assembly so that the (042) Front Wall Tie and (043) Back Wall Tie are tight to Wall Panel as shown in fig.10.1. Loosely attach the assembly using 4 (H10) 1/4 x 2-1/4" Hex Bolts (with lock washer, flat washer and t-nut). (fig. 10.1 and 10.2)

B: Place (101) Nest Center Joist so that it lines up with the remaining set of pre-drilled holes in the (041) Nest Mid Joist and the center of (071) Nest End Panel and attach using 4 (S3) #8 x 2-1/2" Wood Screws. (fig. 10.3 and 10.4)

C: Make sure that assembly is level and install 4 (S11) #8 x 2" Wood Screws into (042) Front Wall Tie and (043) Back Wall Tie as shown in fig.10.5. Tighten all bolts. (fig. 10.3 and 10.5)

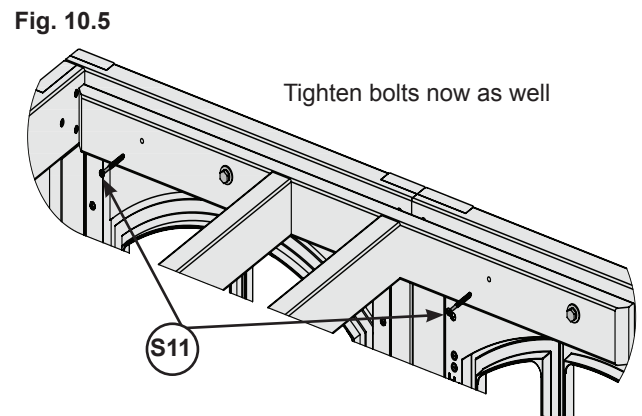
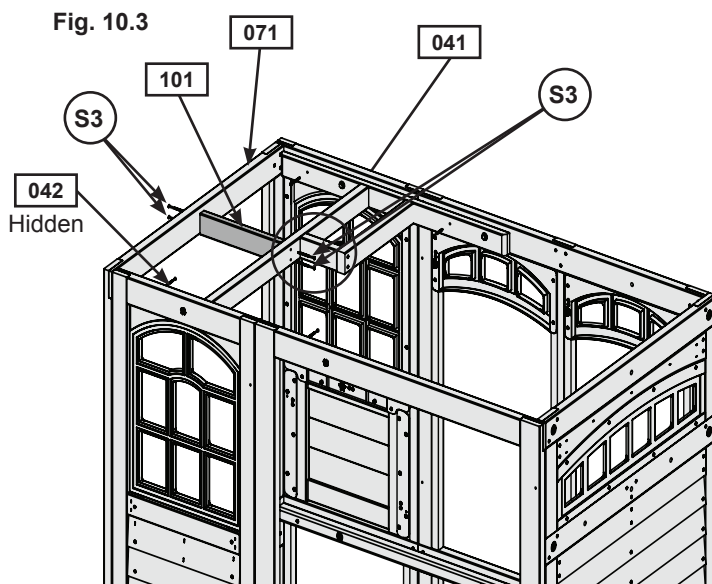
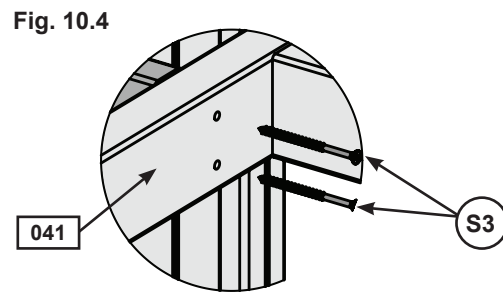
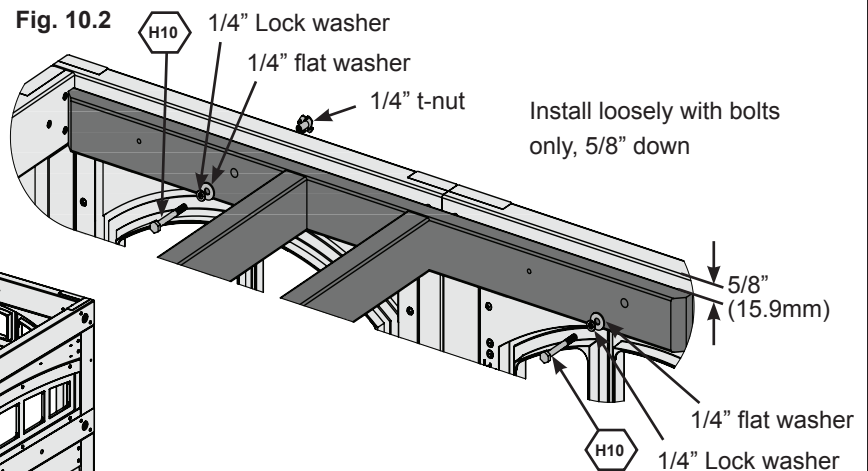
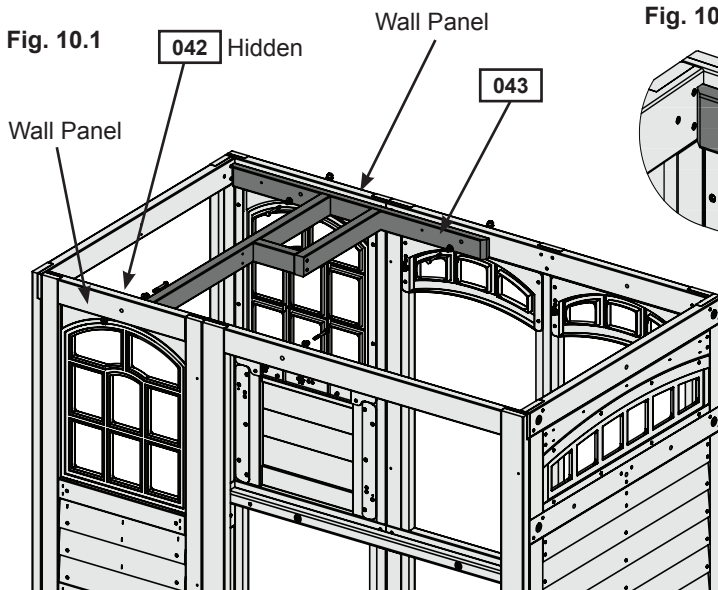

Wood Parts

1 x **101** Nest Center Joist 15/16 x 2-3/8 x 12-1/8"

Hardware

4 x **S3** #8 x 2-1/2" Wood Screw

4 x **S11** #8 x 2" Wood Screw

4 x **H10** 1/4 x 2-1/4" Hex Bolt (with 1/4" lock washer, 1/4" flat washer and 1/4" t-nut)

Step 11: Install Brackets

A: On the inside of the assembly attach (072) Narrow Panel Back to (083) Wall Panel Back using 2 Flat Panel Brackets in the places shown with 4 (S8) #12 x 3/4" Pan Screws per bracket. (fig. 11.1 and 11.2)

B: Repeat Step A to attach (073) Narrow Front Panel to (082) Front Wall Panel. (fig. 11.1 and 11.2)

C: In each bottom corner of the assembly attach 1 Panel Corner Bracket with 4 (S8) #12 x 3/4" Pan Screws per bracket. (fig. 11.1 and 11.3)

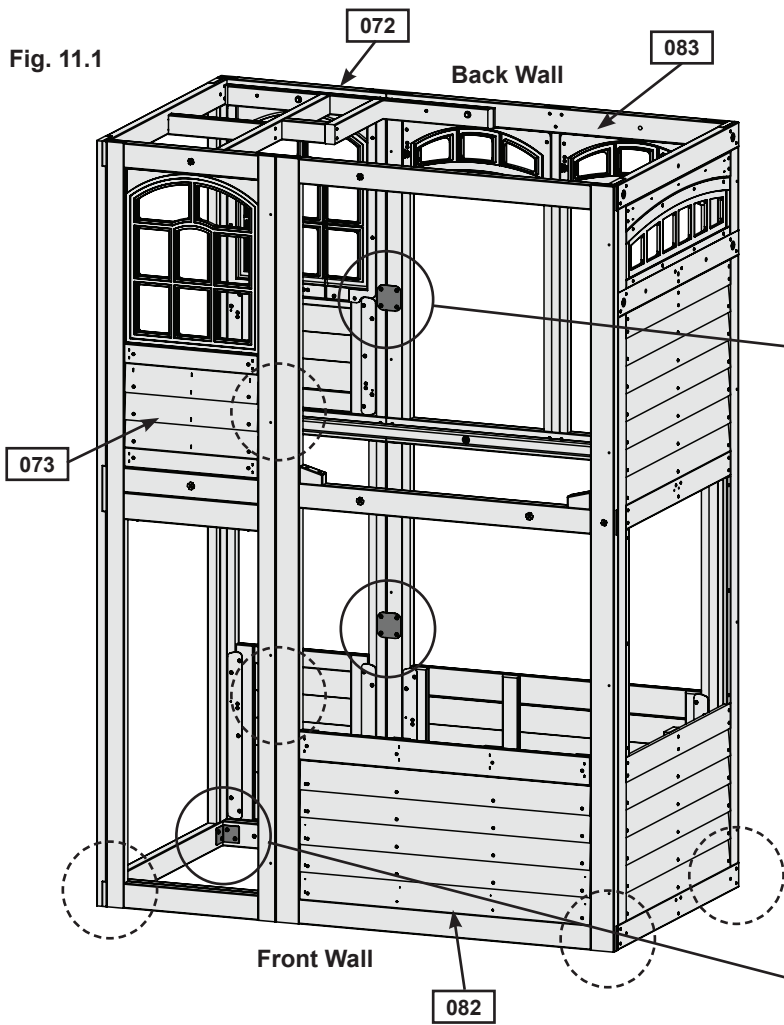

Fig. 11.2
Inside View

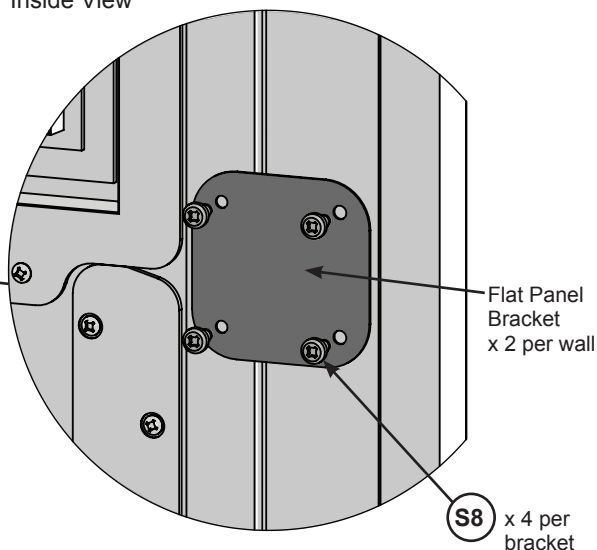
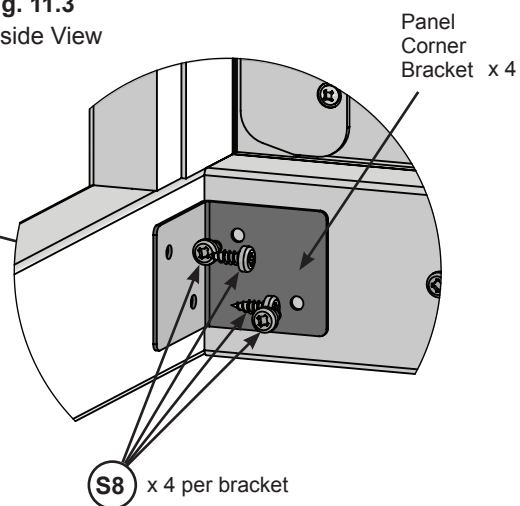

Fig. 11.3
Inside View



Hardware

32 x (S8) #12 x 3/4" Pan Screw

Other Parts

4 x Flat Panel Bracket
4 x Panel Corner Bracket

Step 12: Floor Assembly Part 1



A: Place 1 (121) Floor Board tight to (071) Nest End Panel and place a second (121) Floor Board tight to (081) SW Wall Panel. Attach each Floor Board to the (092) Side Joists with 4 (S20) #8 x 1-3/8" Wood Screws per board. (fig. 12.1 and 12.2)

B: From underneath, place (122) Long Floor Joist centered and tight to the bottom of each (121) Floor Board. Make sure that (122) Long Floor Joist is centred over the pilot holes on the (071) Nest End Panel and (081) SW Wall Panel then attach with 2 (S4) #8 x 3" Wood Screws per panel. Attach (121) Floor Boards to (122) Long Floor Joist with 2 (S20) #8 x 1-3/8" Wood Screws per board. (fig. 12.1, 12.2 and 12.3)

Fig. 11.1

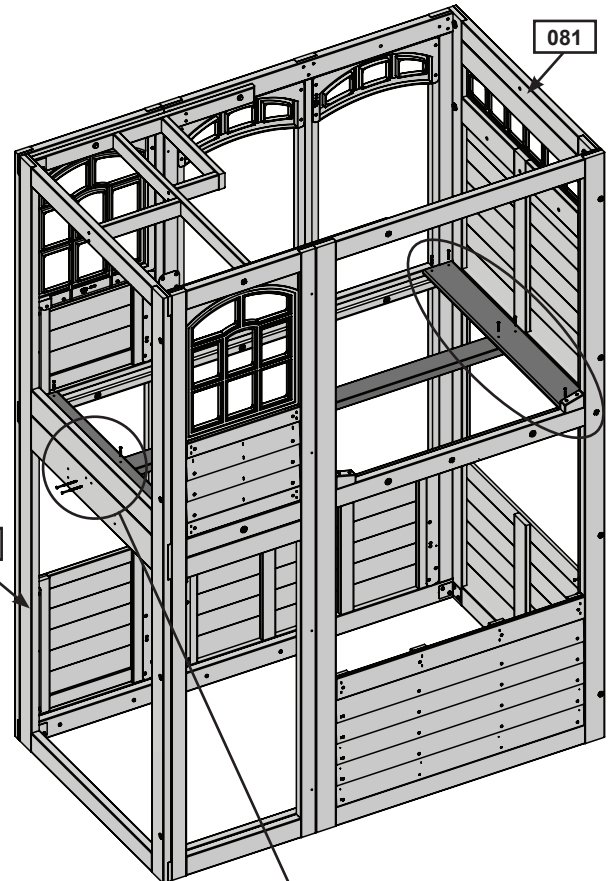

Fig. 11.2

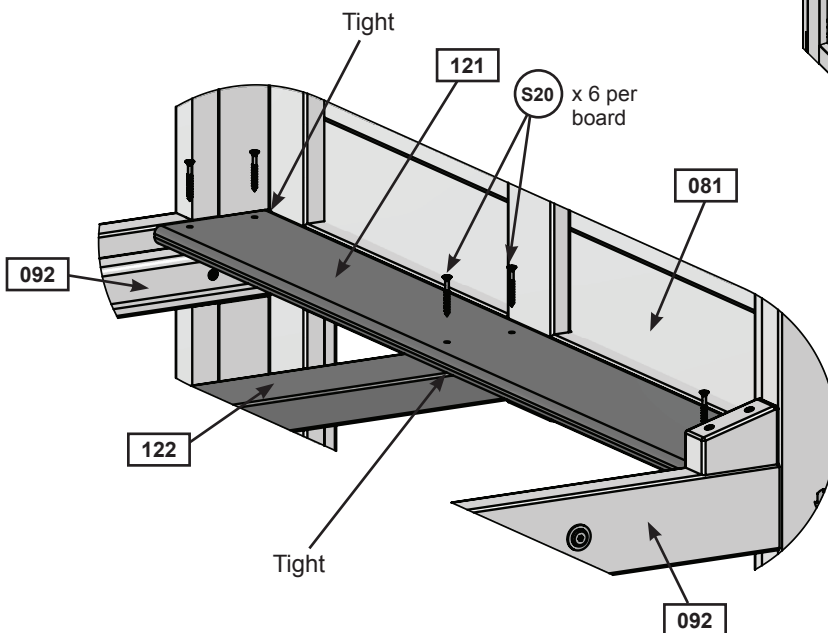
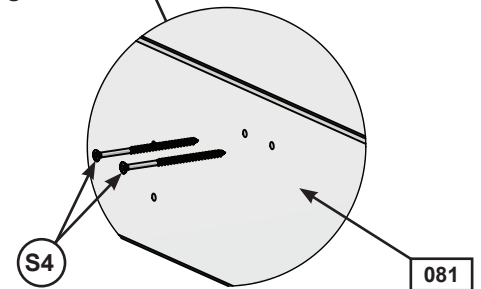

Fig. 11.3



Wood Parts

- 2 x 121 Floor Board 5/8 x 4-1/2 x 35-5/8"
- 1 x 122 Long Floor Joist 1-1/4 x 3 x 63-1/4"

Hardware

- 12 x S20 #8 x 1-3/8" Wood Screw
- 4 x S4 #8 x 3" Wood Screw

Step 12: Floor Assembly Part 2



C: Measure the distance from the Back Wall to the Front Wall from the inside of the panels to make sure it equals 35-3/4". Maintain this measurement when installing the floor boards. Starting at the Slide Wall place 3 (121) Floor Boards tight to the previously attached (121) Floor Board, followed by 1 (123) Floor Board then 8 more (121) Floor Boards. Make sure all boards are equally spaced then attach to (122) Long Floor Joist and each (092) Side Joist with 6 (S20) #8 x 1-3/8" Wood Screws per board. (fig. 12.4, 12.5 and 12.6)

Fig. 12.4

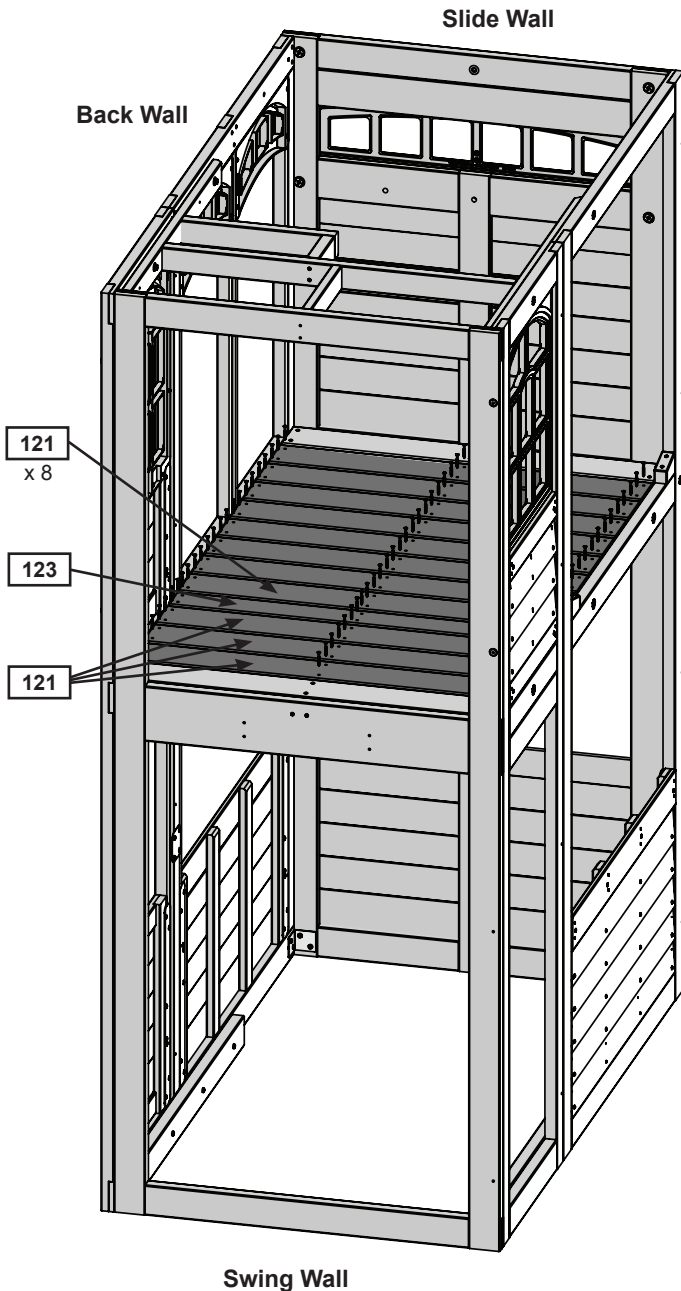

Fig. 12.5
Top View

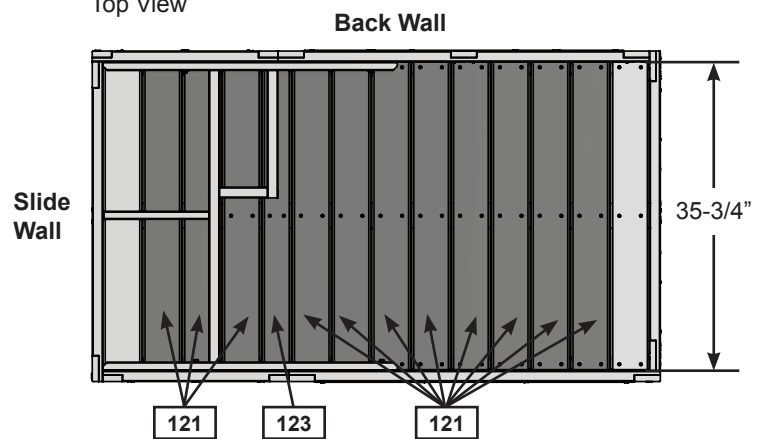
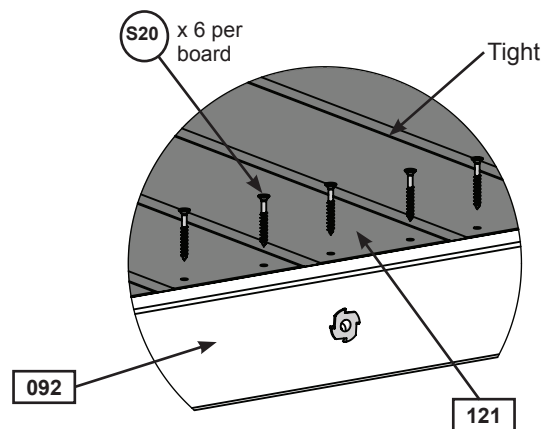

Fig. 12.6



Wood Parts

- 11 x 121 Floor Board 5/8 x 4-1/2 x 35-5/8"
- 1 x 123 Floor Board 5/8 x 3-3/8 x 35-5/8"

Hardware

- 72 x S20 #8 x 1-3/8" Wood Screw

Step 13: Attach Wall Tops

A: In the opening of (081) SW Wall Panel, from the inside, place (131) SW Wall Top, tight to the corner of the panels with overhang facing in. Attach using 1 (S11) #8 x 2" Wood Screw at each end as shown in fig. 13.1 and 13.2.

B: In the opening of (083) Wall Panel Back, from the inside, attach (132) Wall Top tight to the corner of the panel with overhang facing in using 1 (S11) #8 x 2" Wood Screw at each end as shown in fig. 13.1 and 13.3.

C: At the top of each slat, flush to the wall tops, attach 1 Corner Bracket using 3 (S37) #7 x 5/8" Pan Screws per bracket. (fig. 13.1 and 13.3)

Fig. 13.2
Inside View

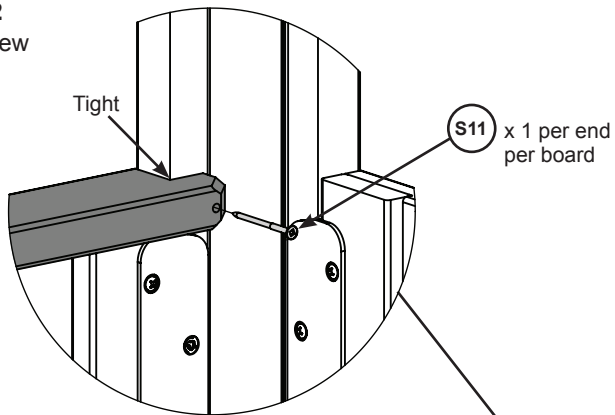

Fig. 13.3
Inside View

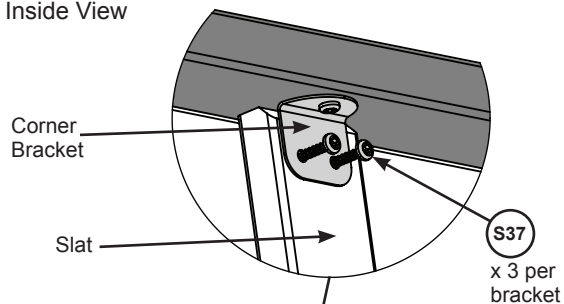
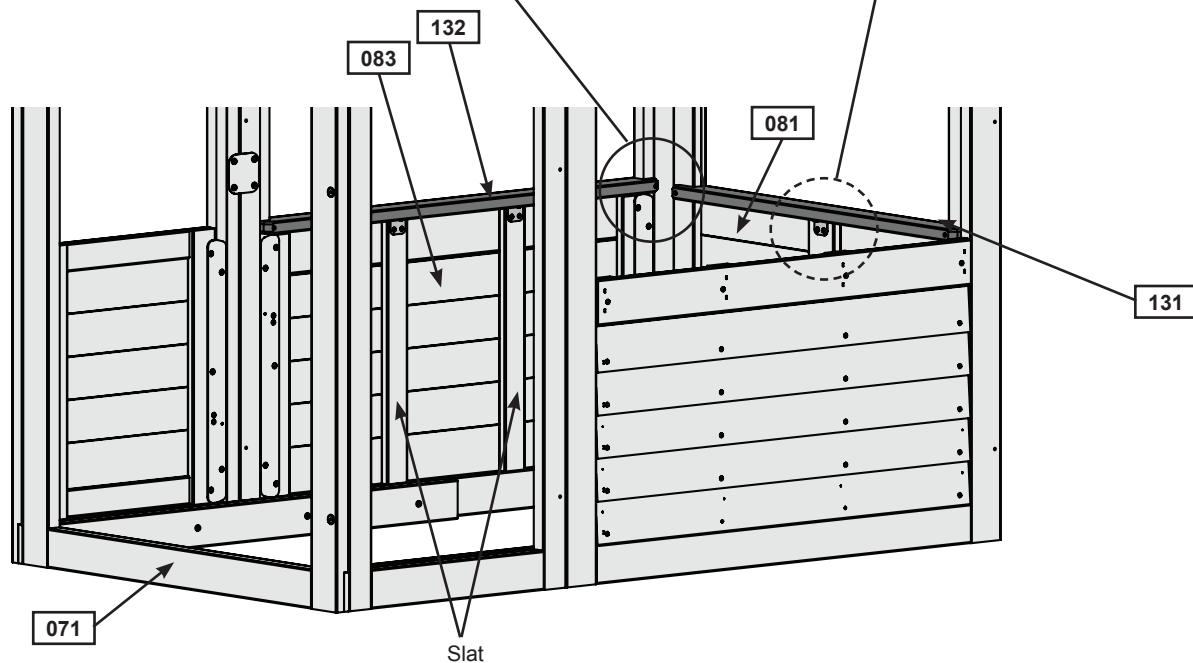

Fig. 13.1



Wood Parts

- 1 x 131 SW Wall Top 15/16 x 2-3/8 x 33-1/2"
- 1 x 132 Half Wall Top 15/16 x 2-3/8 x 39"

Hardware

- 4 x S11 #8 x 2" Wood Screw
- 9 x S37 #7 x 5/8" Pan Screw

Other Parts

- 3 x Corner Bracket

Step 14: Attach Diagonal

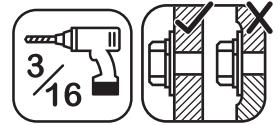

A: Loosely attach (141) SW Ground to (142) Diagonal with 1 (WB9) 5/16 x 2-1/8" Wafer Bolt (with flat washer and t-nut) then place (142) Diagonal tight and flush to the front of (081) SW Wall Panel. The (141) SW Ground should be flush to the bottom of (081) SW Wall Panel. (fig. 14.1 and 14.2)

B: Pre-drill pilot hole with a 3/16" drill bit then attach (142) Diagonal to (081) SW Wall Panel with 1 (WL5) 1/4 x 2-1/2" Wafer Lag (with flat washer), checking that it remains flush to outside edge. (fig. 14.1 and 14.2)

C: Make sure bottom of (141) SW Ground is flush to bottom of (081) SW Wall Panel then attach with 2 (S11) #8 x 2" Wood Screws and 1 (S4) #8 x 3" Wood Screw. Tighten the (WB9) Wafer Bolt installed in Step A. (fig. 14.1 and 14.2)

Fig. 14.1

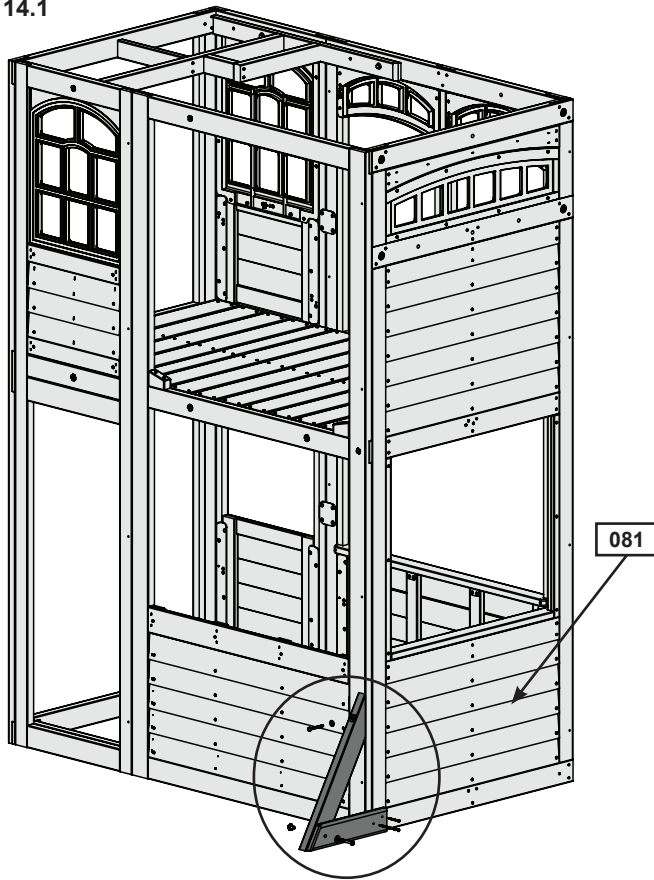
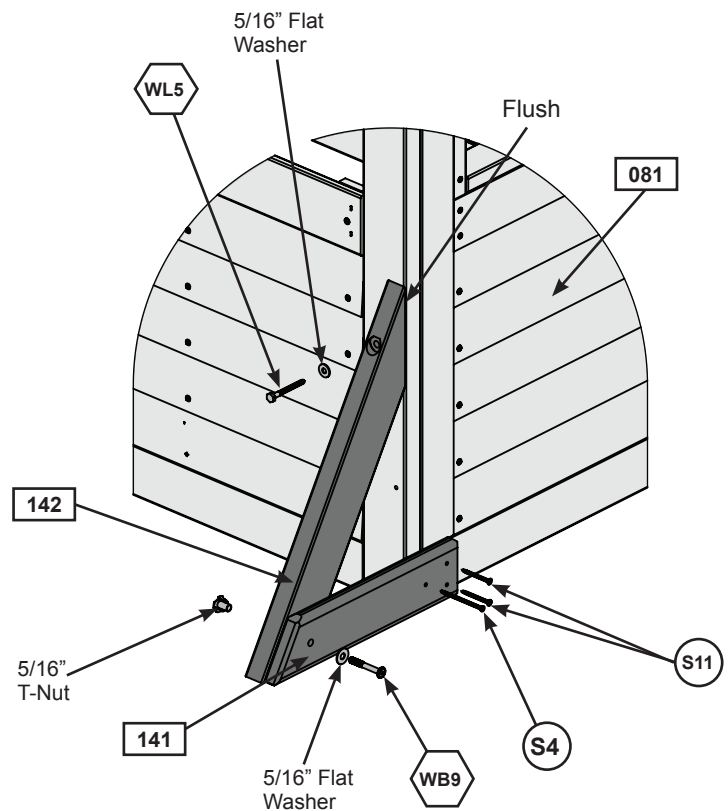

Fig. 14.2



Wood Parts

- 1 x 141 SW Ground 15/16 x 3-1/4 x 14-1/4"
- 1 x 142 Diagonal 1-1/4 x 3 x 22"

Hardware

- 1 x WB9 5/16 x 2-1/8" Wafer Bolt (5/16" flat washer, 5/16" t-nut)
- 1 x WL5 1/4 x 2-1/2" Wafer Lag (5/16" flat washer)
- 1 x S4 #8 x 3" Wood Screw
- 2 x S11 #8 x 2" Wood Screw

Step 15: Attach Access Ladder/Rope Wall Assembly Part 1

A: Place Access Ladder/Rockwall Assembly from Step 3 against (083) Wall Panel Back, flush to the outside edge and flush to the top of the floor boards then attach with 3 (WB9) 5/16 x 2-1/8" Wafer Bolt (with flat washer). (fig. 15.1 and 15.2)

Fig. 15.1

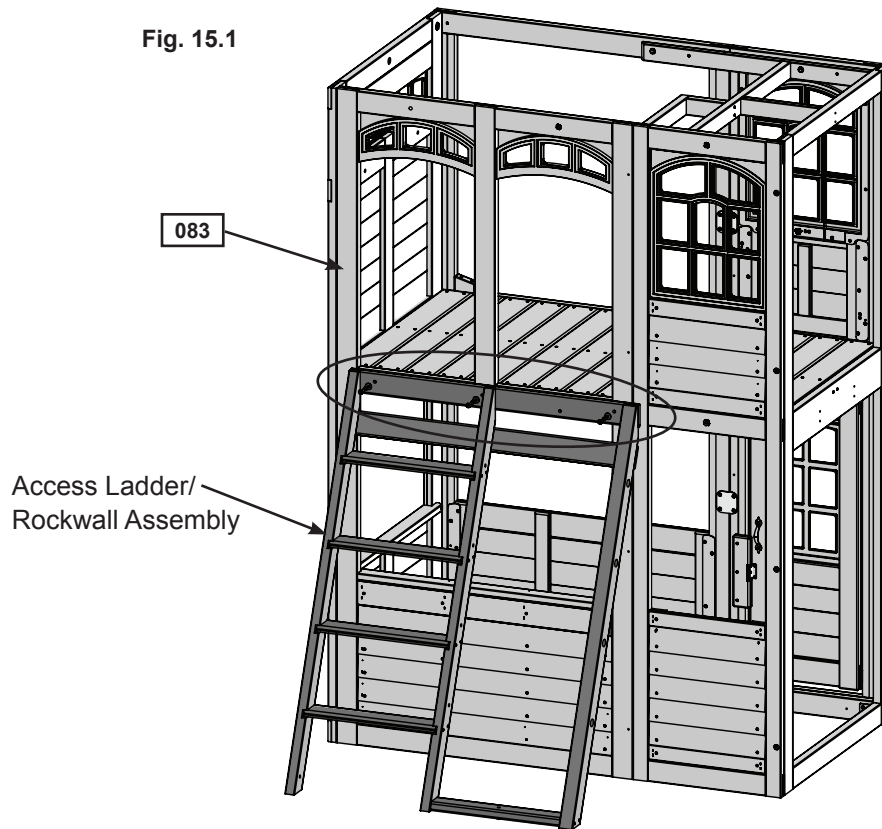
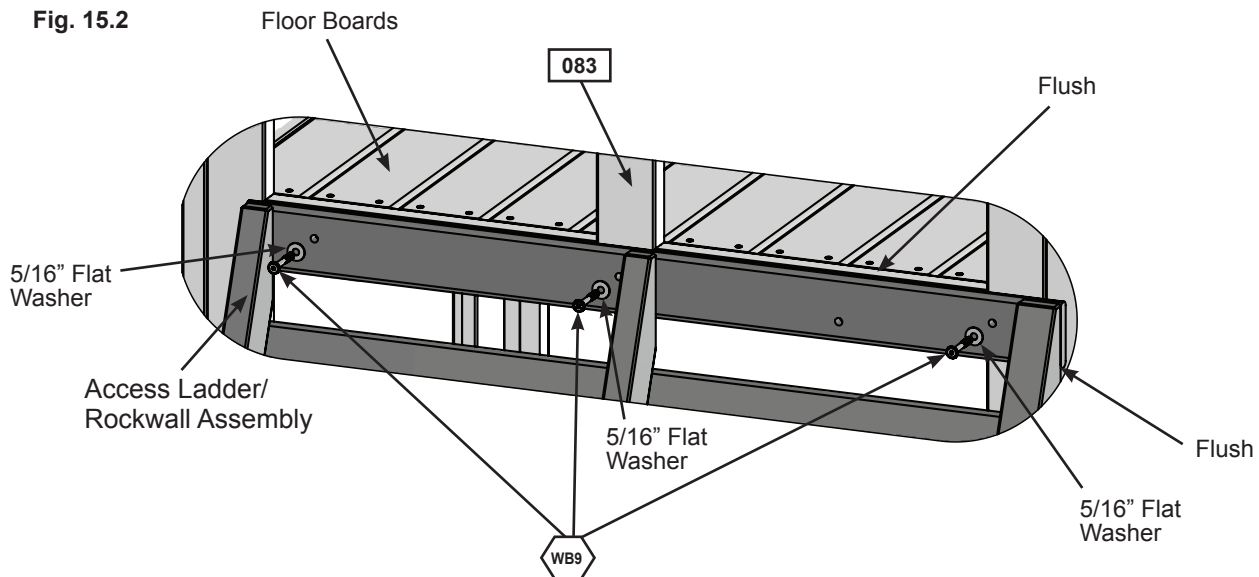

Fig. 15.2



Hardware

3 x  5/16 x 2-1/8" Wafer Bolt (5/16" flat washer)

Step 15: Attach Access Ladder/Rope Wall Assembly Part 2

B: Starting with the top of the rope ladder, insert the bolt through the hole in (025) RW-AL Support and tighten bolt to connect it to the (M8) t-nut (previously installed). Attach the sides of the rope ladder to each access rail and the bottom end into the (027) Rope Bottom using the flat washers and lock nuts provided. (Fig. 15.3 and 15.4)

Fig. 15.4

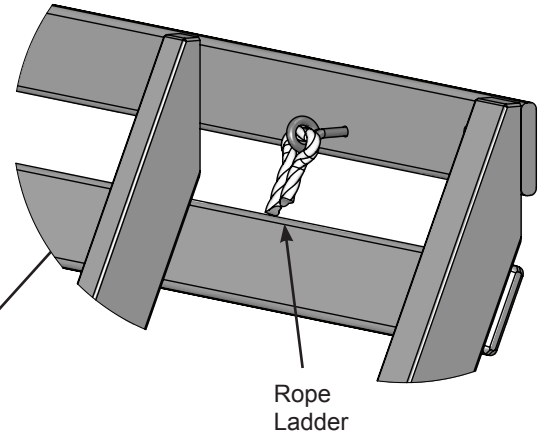
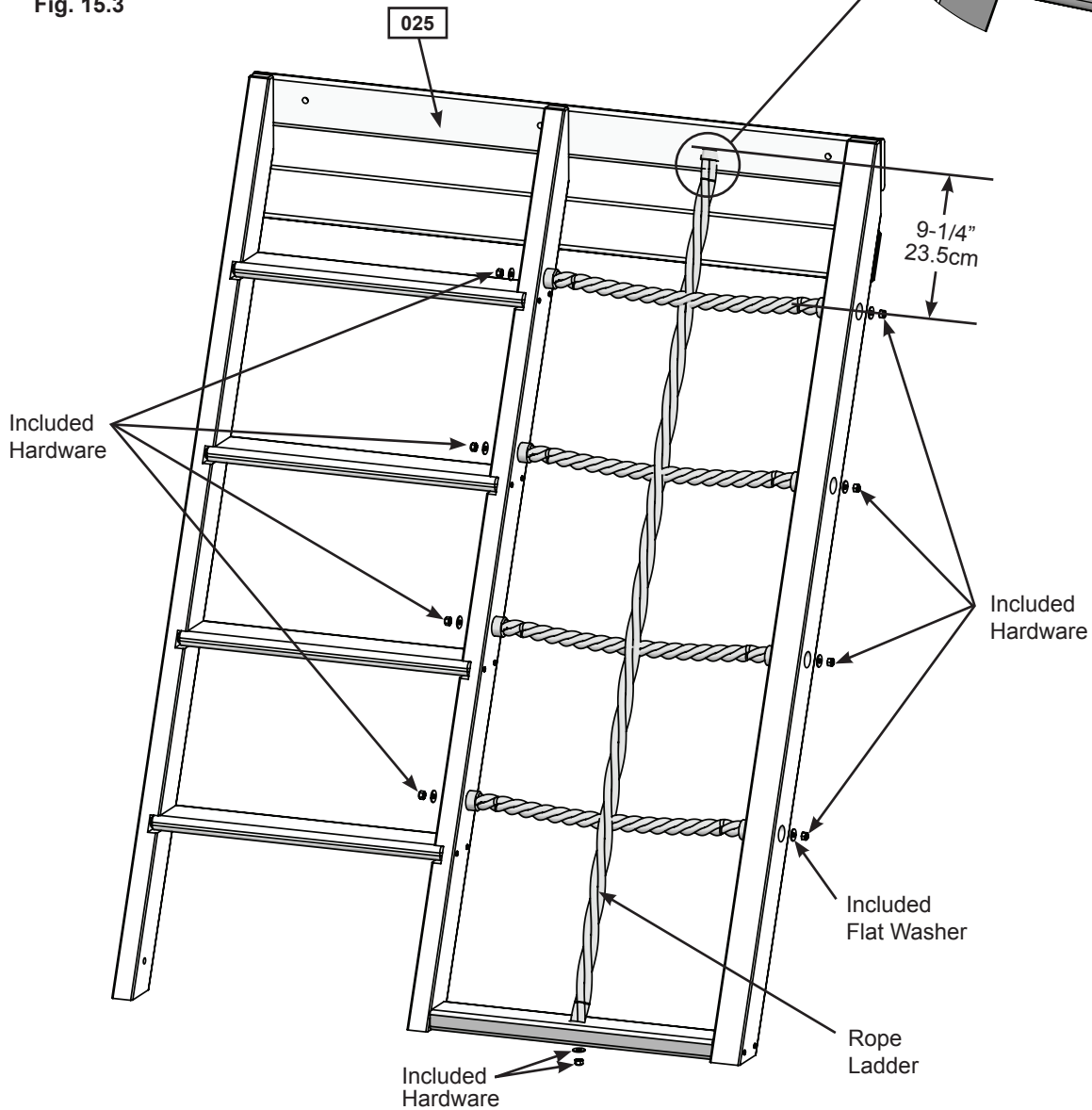

Fig. 15.3



Other Parts

Rope Ladder with Hardware

Step 15: Attach Access Ladder/Rope Wall Assembly Part 3

C: Place (151) Support Diagonal so that the angled end is flush to the front edge and to the bottom of (021) Left Access Rail. The opposite end should be tight against (083) Wall Panel Back. Attach (151) Support Diagonal to (021) Left Access Rail using 1 (H10) 1/4 x 2-1/4" Hex Bolt (with lock washer, flat washer and t-nut). (fig. 15.5 and 15.6)

D: Center 1 Corner Panel Bracket on each side of (151) Support Diagonal so that each bracket is flat against the brace and the wall panel as shown in (fig. 15.4). Attach each Corner Panel Bracket using 4 (S0) #8 x 7/8" Truss Screws. (fig. 15.5 and 15.6)

Fig. 15.5

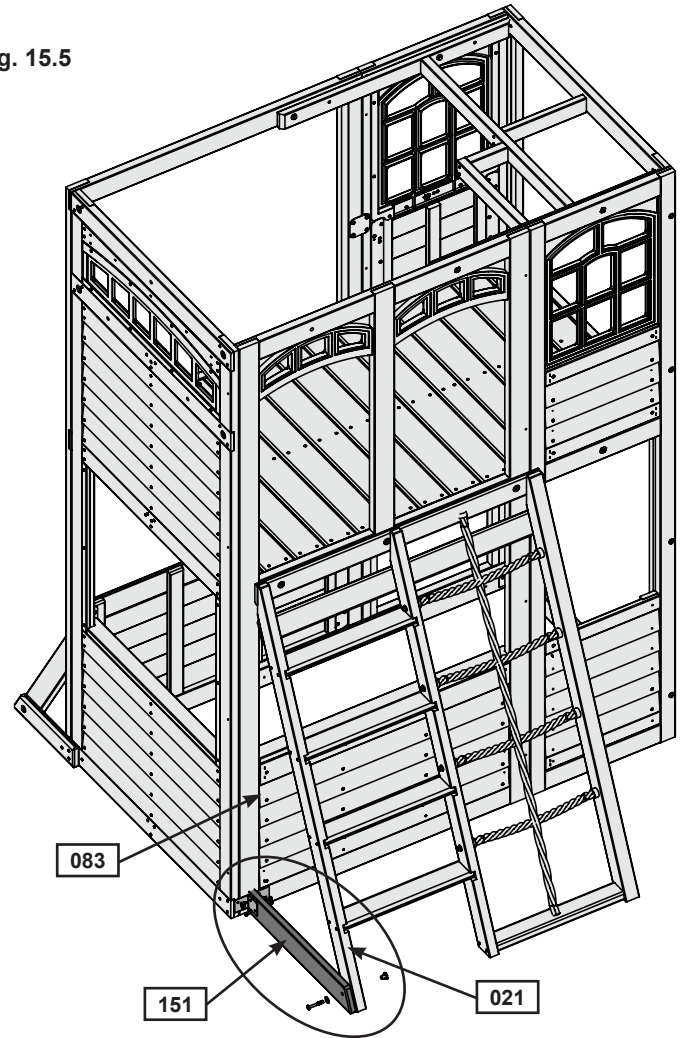
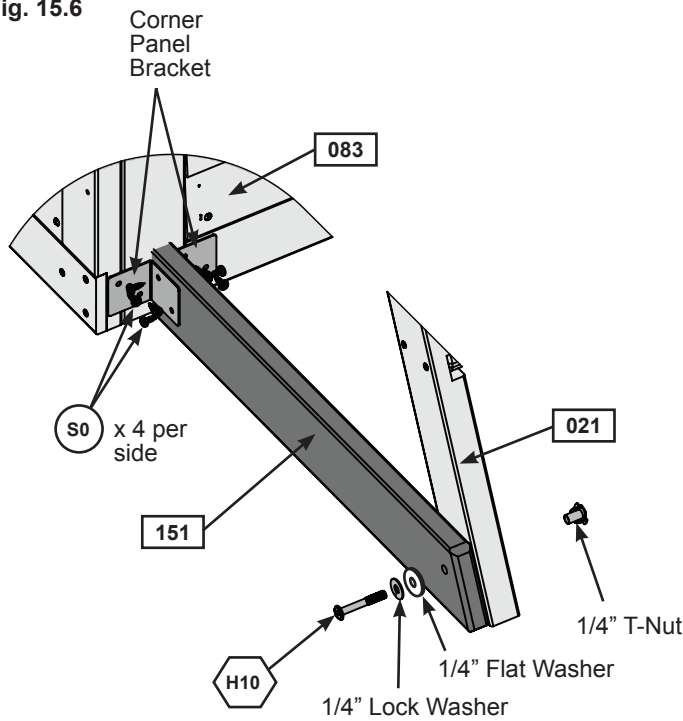

Fig. 15.6



Wood Parts

1 x **151** Support Diagonal 15/16 x 3-1/4 x 23-11/16"

Hardware

8 x **S0** #8 x 7/8" Truss Screw
1 x **H10** 1/4 x 2-1/4" Hex Bolt (with 1/4" lock washer, 1/4" flat washer and 1/4" t-nut)

Other Parts

2 x Corner Panel Bracket

Step 16: Attach Steel Hand Grips and Handrail to Fort Part 1

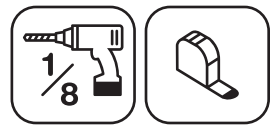

A: On the (083) Back Wall Panel, measure 5-1/2" up from the (025) RW-AL Support in the 2 locations shown in fig. 16.1. Place the Steel Hand Grips in position and mark the hole locations on the panel. Pre-drill with a 1/8" drill bit making sure the holes are centered then attach each Steel Hand Grip using 2 (WL3) 1/4 x 1-3/8" Wafer Lags (with flat washer). (fig. 16.1 and 16.2)

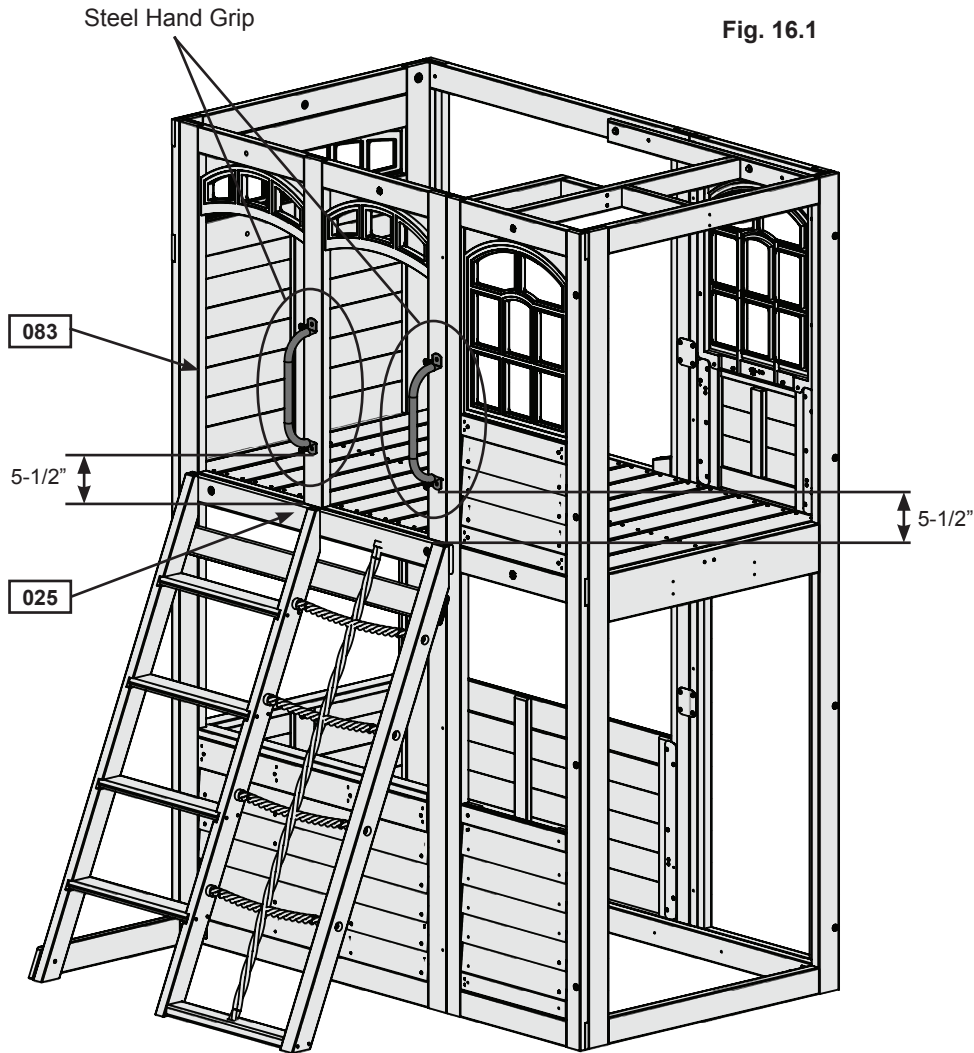
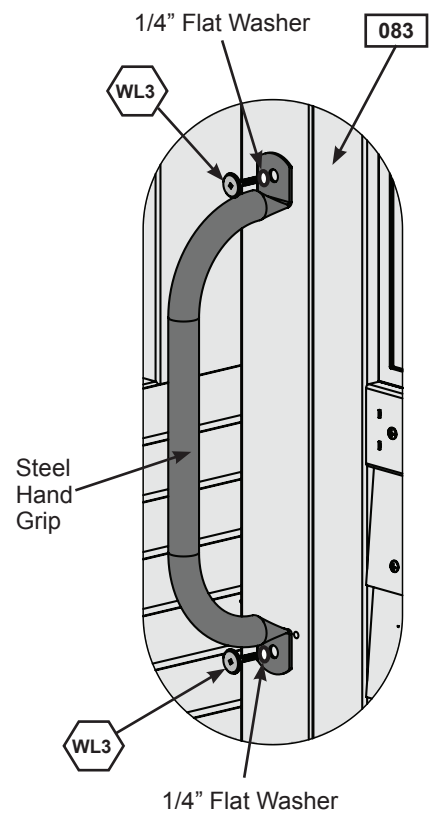



Fig. 16.1

Fig. 16.2



Hardware
 4 x  1/4 x 1-3/8" Wafer Lag
 (1/4" flat washer)

Other Parts
 2 x Steel Hand Grip

Step 16: Attach Steel Hand Grips and Handrail to Fort Part 2

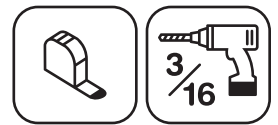

A: On the inside edge of (083) Back Wall Panel, measure 2" up from the floor and place EN71 Hand Rail so it is flush to the edge as shown in fig. 16.4. The bottom of the Handrail should be centered on (021) Left Access. Pre-drill holes using a 3/16" (4.8 mm) drill bit then attach EN71 Hand Rail using 2 (WL3) 1/4 x 1-3/8" Wafer Lags (with flat washer). (fig. 16.3 and 16.4)

Fig. 16.3

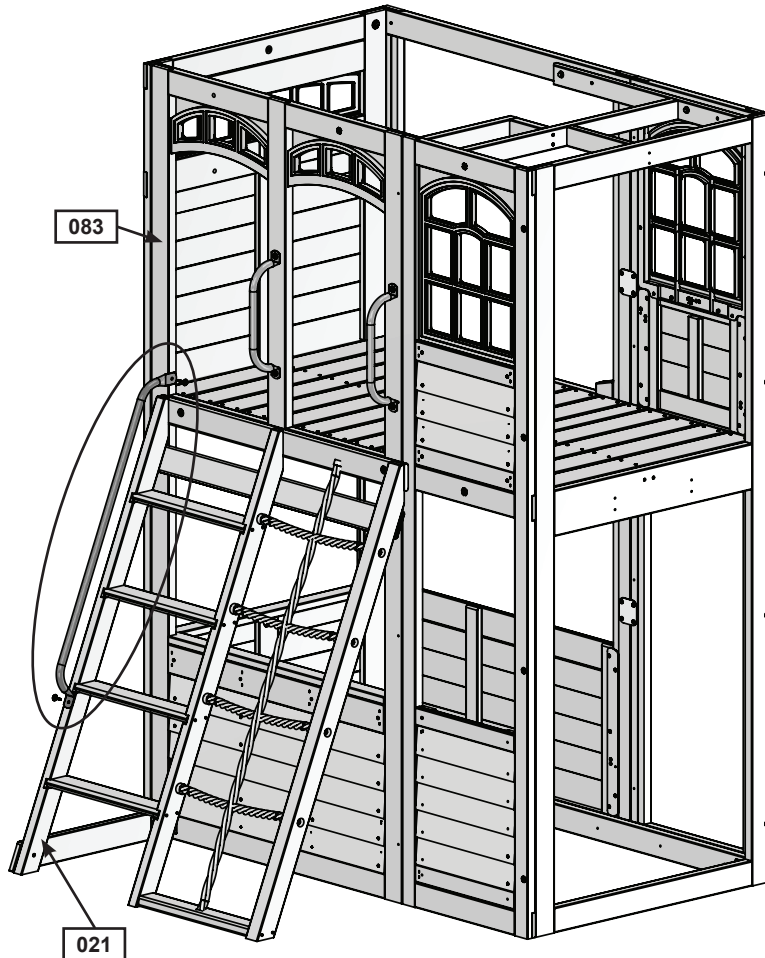
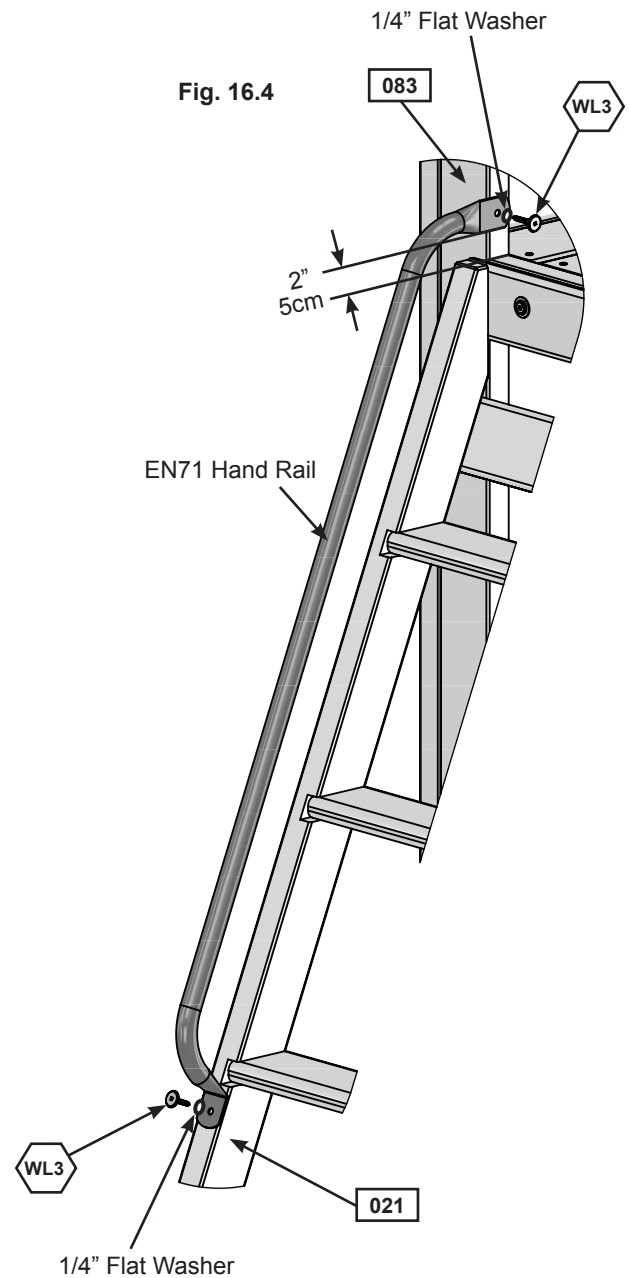



Fig. 16.4



Hardware
 2 x  1/4 x 1-3/8" Wafer Lag
 (1/4" flat washer)

Other Parts
 1 x EN71 Hand Rail

Step 17: Door Panel Assembly Part 1



A: On the inside of (171) Door Window Panel measure 15" up from the bottom and attach Catch Plate flush to the edge using 2 (S38) #7 x 1-1/8" Pan Screws. (fig. 17.1 and 17.2)

B: On the inside of (171) Door Window Panel measure 22" up from the bottom and attach 1 Door Handle using 2 (S37) #7 x 5/8" Pan Screws. (fig. 17.1 and 17.2)

Fig. 17.1

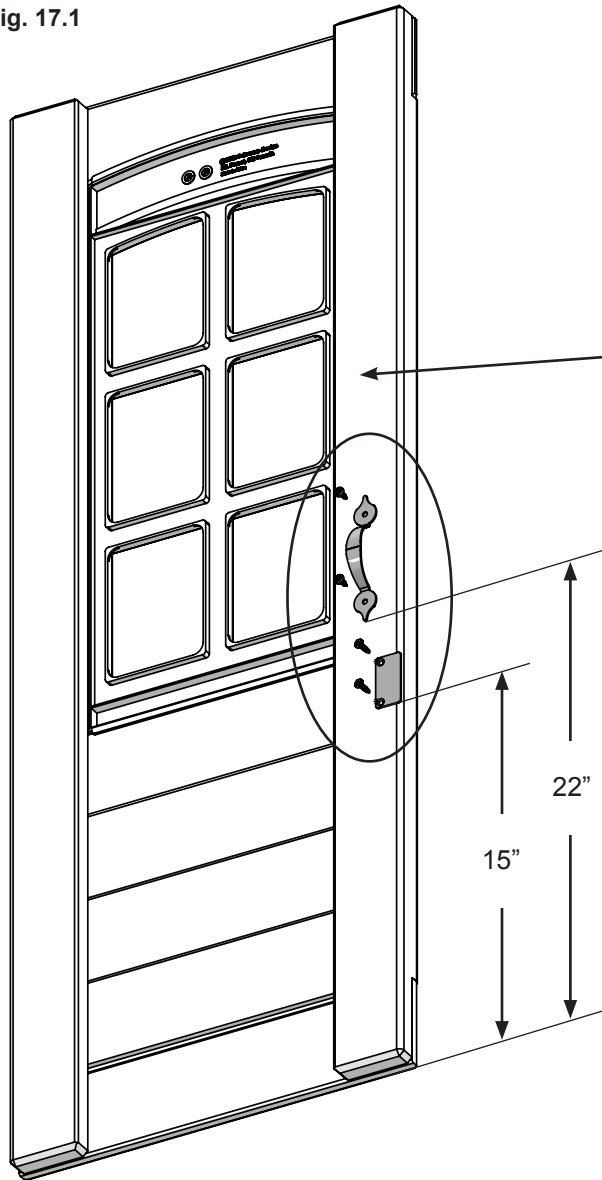

Inside View

Fig. 17.2

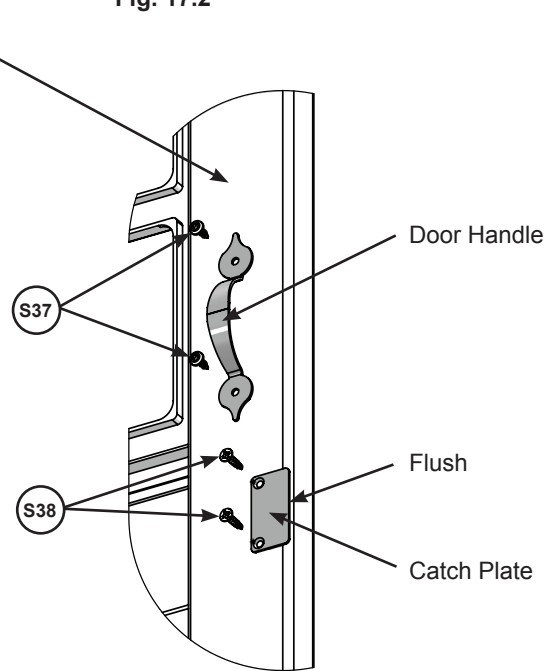

Wood Parts

1 x 171 Door Window Panel 1-1/4 x 15-3/4 x 42-1/8"

Hardware

2 x S38 #7 x 1-1/8" Pan Screw
2 x S37 #7 x 5/8" Pan Screw

Other Parts

1 x Door Handle
1 x Catch Plate

Step 17: Door Panel Assembly Part 2

C: On the outside of the (171) Door Window Panel attach the second Door Handle at approximately the same place as the one on the inside. Use 2 (S37) #7 x 5/8" Pan Screws. (fig. 17.3)

D: Attach 2 Door Hinges on the outside of the (120) Door Window Panel on the opposite side from the Door Handle. Judge spacing based on fig. 17.3. Use 3 (S37) #7 x 5/8" Pan Screws per Hinge.

Note: Hinge stops must be tight to (171) Door Window Panel. (fig. 17.4)

Fig. 17.3

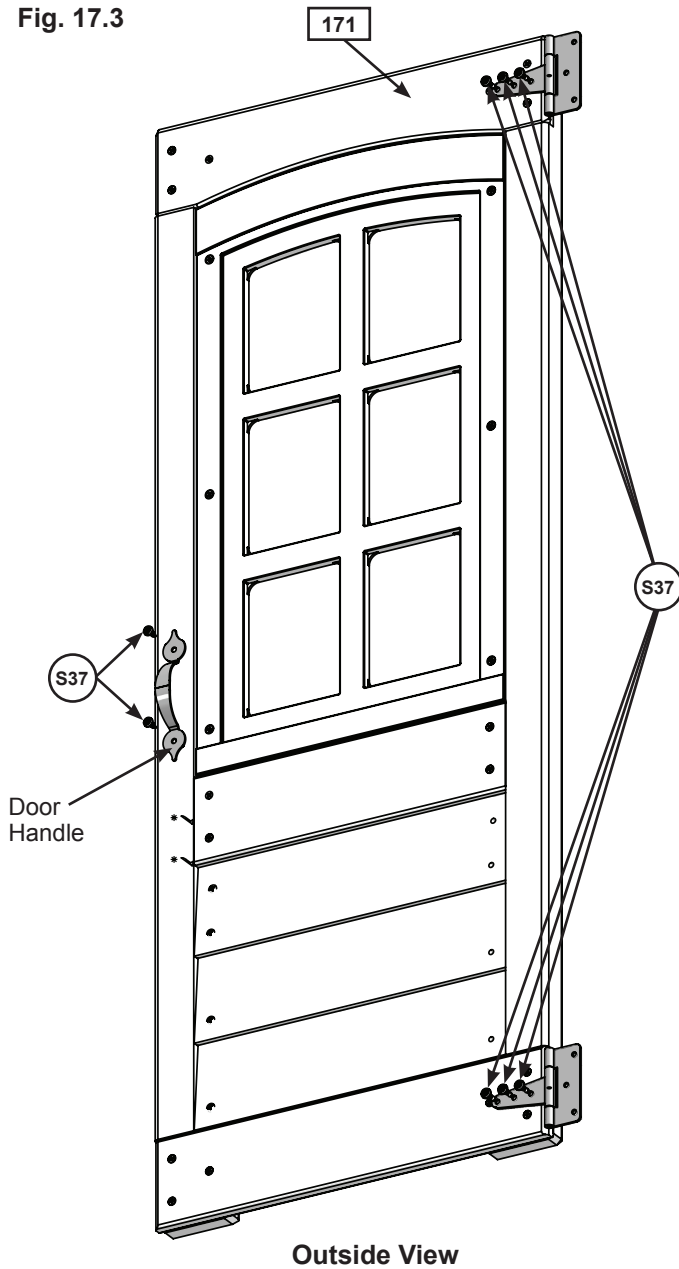
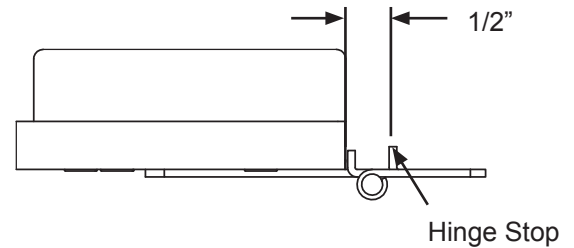

Fig. 17.4
Top View



Hardware

8 x (S37) #7 x 5/8" Pan Screw

Other Parts

1 x Door Handle
2 x Door Hinge

Step 17: Door Panel Assembly Part 3



E: In the opening for the door, measure $3/4$ " from the top of (073) Narrow Front Panel bottom and maximum $5/8$ " from left side of the opening which would be the Door Hinge side and attach the remaining side of the hinges to (073) Narrow Front Panel using 3 (S37) #7 x $5/8$ " Pan Screws per hinge. (fig. 17.5 and 17.6)

Fig. 17.5

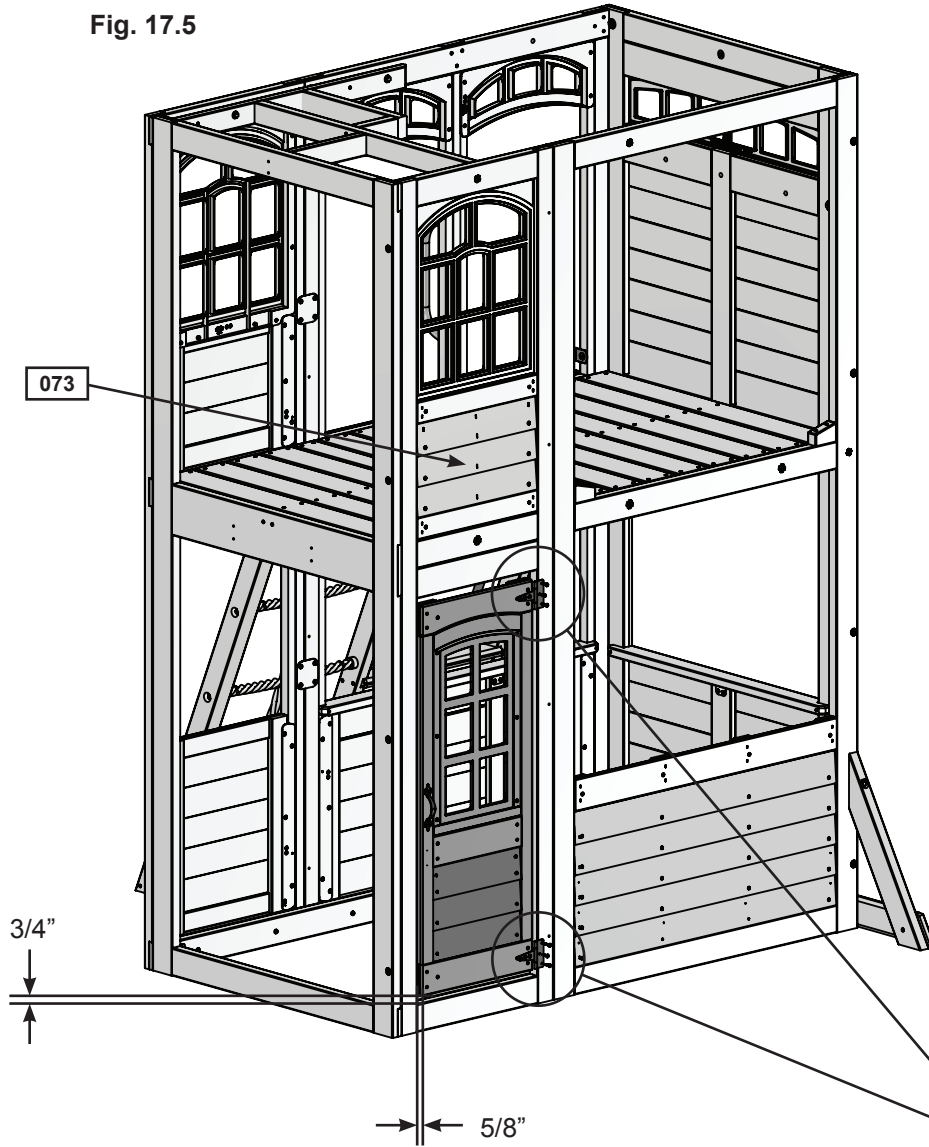
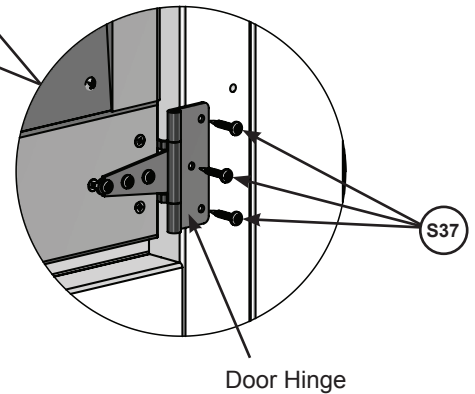

Fig. 17.6



Hardware

6 x  #7 x $5/8$ " Pan Screw

Step 17: Door Panel Assembly Part 4

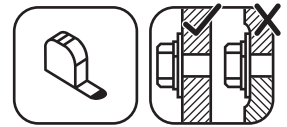

F: In the notched out opening of (172) Door Stop attach the Magnetic Catch using 2 (S38) #7 x 1-1/8" Pan Screws. (fig. 17.7) **Important:** Use a hand held screw driver and **DO NOT** over tighten.

G: On the inside of the assembly, attach (172) Door Stop to (073) Narrow Front Panel with 3 (S11) #8 x 2" Wood Screws, making sure (172) Door Stop overhangs (073) Narrow Front Panel by 1-1/4" and is in position to receive the Catch Plate. (fig. 17.8 and 17.9).

Fig. 17.7

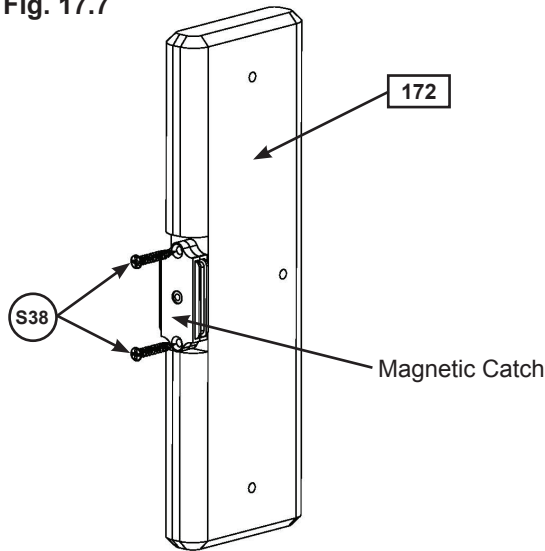

Fig. 17.8
Inside View

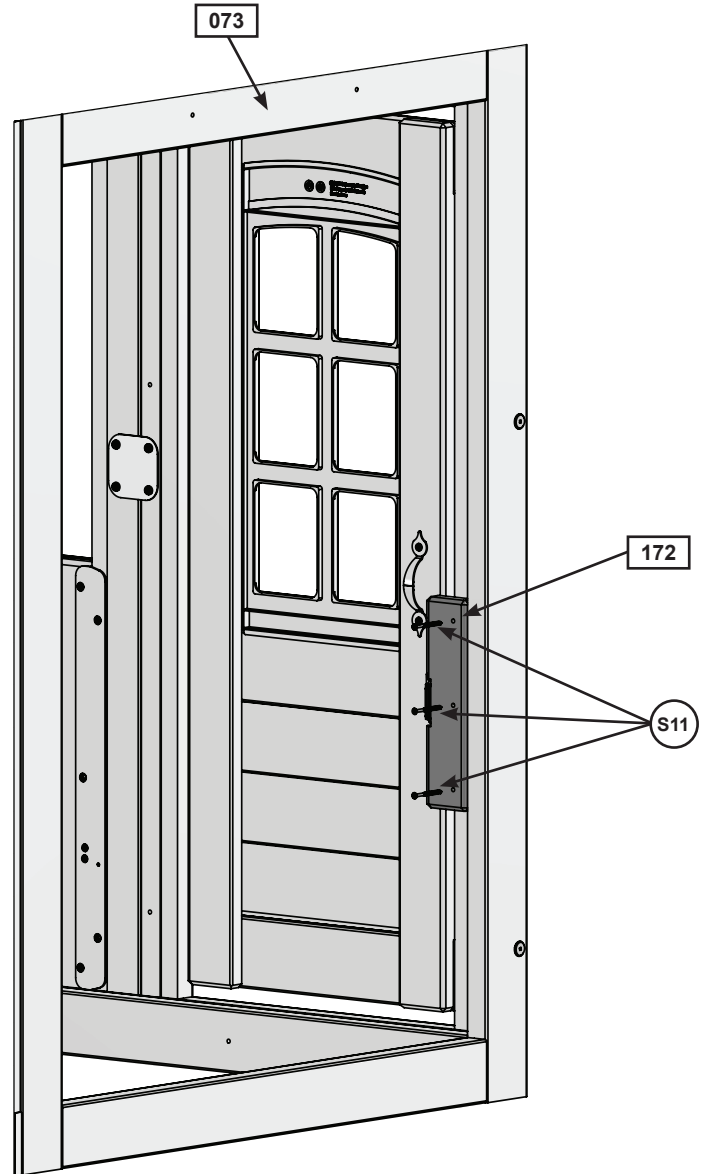
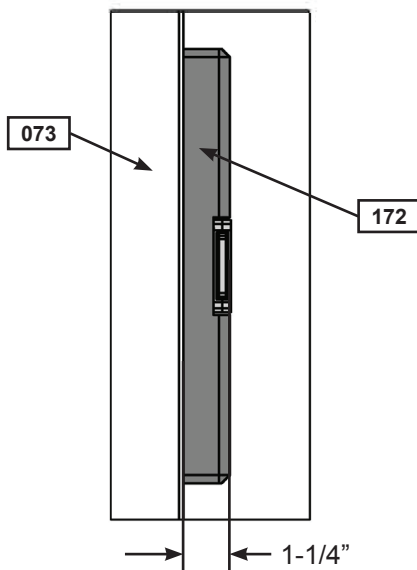

Fig. 17.9
Outside View



Wood Parts

1 x 172 Door Stop 1 x 2-1/2 x 10"

Hardware

2 x S38 #7 x 1-1/8" Pan Screw
3 x S11 #8 x 2" Wood Screw

Other Parts

1 x Magnetic Catch

Step 18: Front Wall Assembly Part 1

A: Center (181) Table Support so that it's flush to the notches in (182) Table Top as shown in fig. 18.1. Attach using 4 (S7) #12 x 2" Pan Screws as shown in fig. 18.1.

B: Place Table Top Assembly in the center of opening and tight to (082) Front Wall Panel and attach (181) Table Support to (082) Front Wall Panel with 2 (S3) #8 x 2-1/2" Wood Screws. (fig. 18.2 and 18.3)

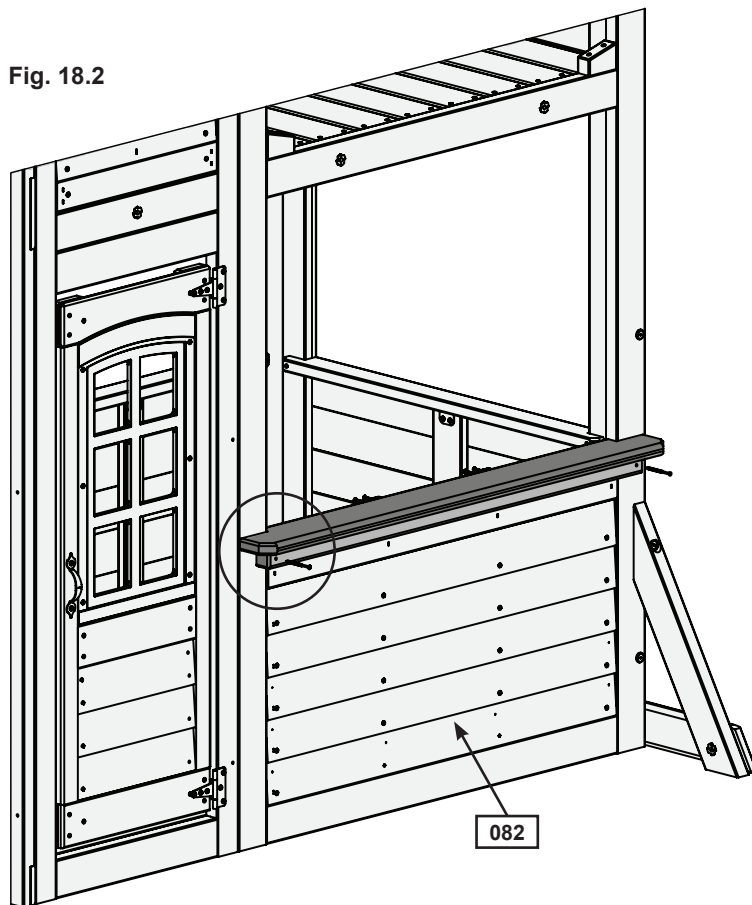
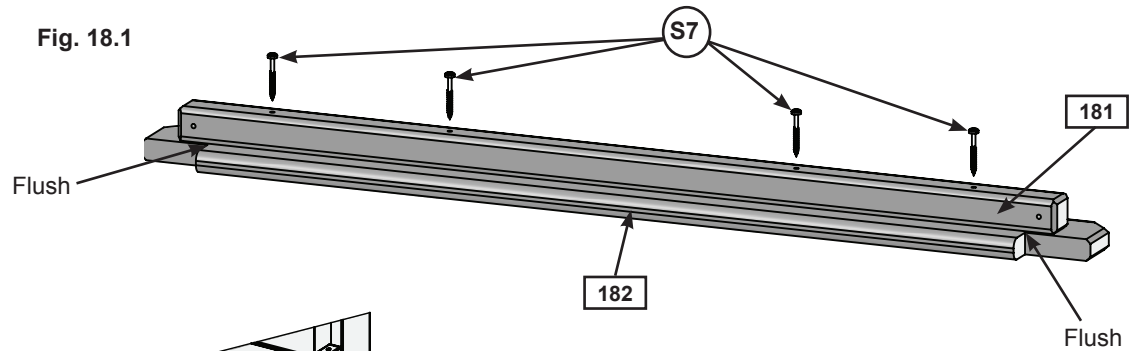
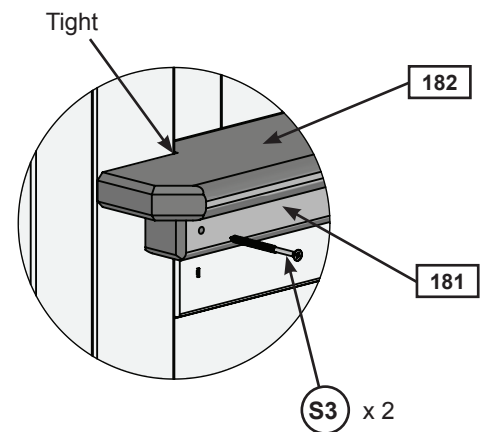

Fig. 18.3
Outside View



Wood Parts

- 1 x 181 Table Support 1-1/2 x 1-1/2 x 39-5/8"
- 1 x 182 Table Top 15/16 x 4-1/4 x 42-3/4"

Hardware

- 4 x S7 #12 x 2" Pan Screw
- 2 x S3 #8 x 2-1/2" Wood Screw

Step 18: Front Wall Assembly Part 2

C: From the inside of the assembly attach (182) Table Top to slats in (082) Front Wall Panel with 2 Flat Brackets using 3 (S0) #8 x 7/8" Truss Screws per bracket. (fig. 18.4 and 18.5)

Fig. 18.4
Inside View

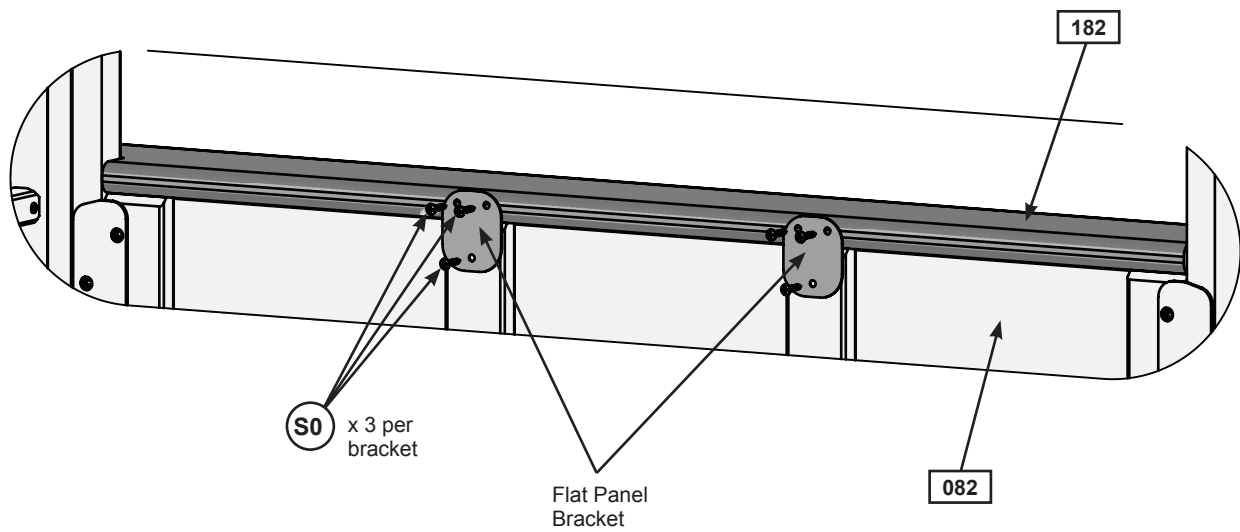

Hardware

6 x (S0) #8 x 7/8" Truss Screw

Other Parts

2 x Flat Bracket

Step 19: Install Bell Assembly Part 1

A: Place (191) Bell Top on top of (192) Bell Support so the angled and back edges are flush then attach with 3 (S20) #8 x 1-3/8" Wood Screws. Repeat by attaching (193) Bell Top Right to top of (192) Bell Support. Rounded ends of (191) Bell Top and (193) Bell Top RT are at the bottom. (fig. 19.1 & 19.2)

B: Centred above the door on (073) Narrow Front Panel place each Bell Support Assembly so they are tight and form a peak then attach to (073) Narrow Front Panel with 1 (S3) #8 x 2-1/2" Wood Screw and 1 (S11) #8 x 2" Wood Screw per assembly. (fig. 19.3)

Fig. 19.1
Top View

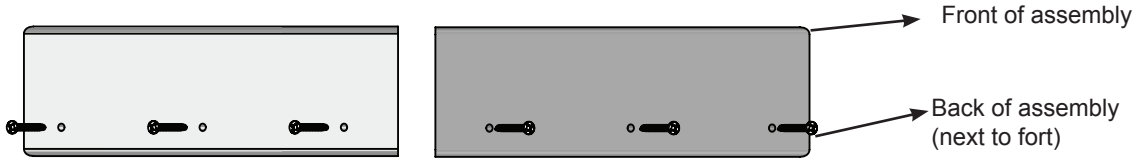

Fig. 19.3

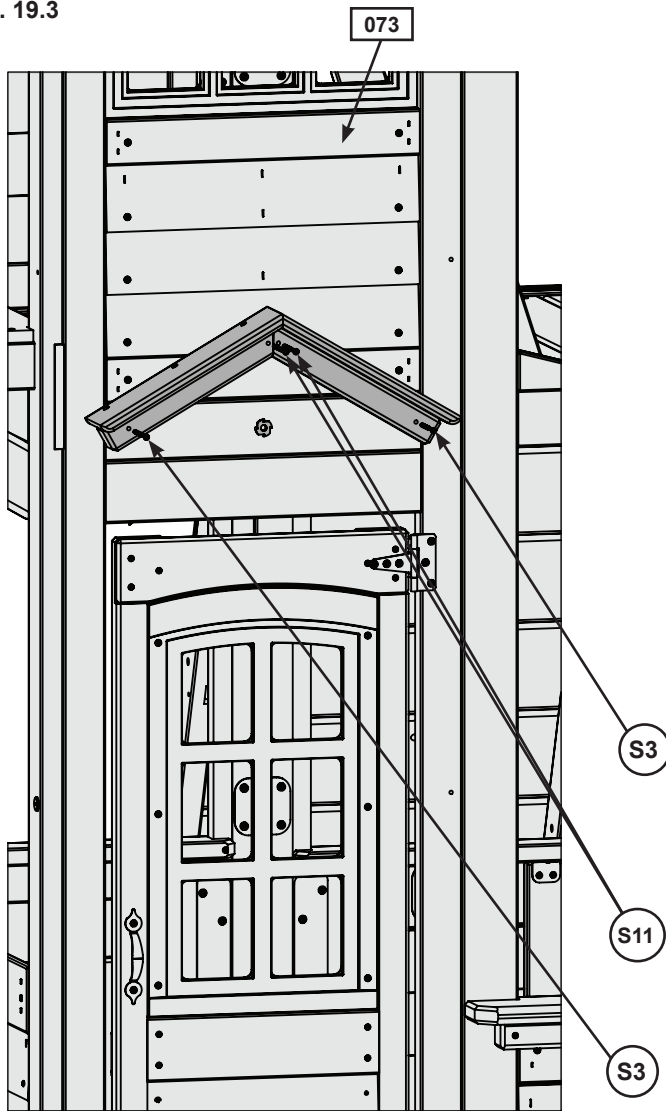
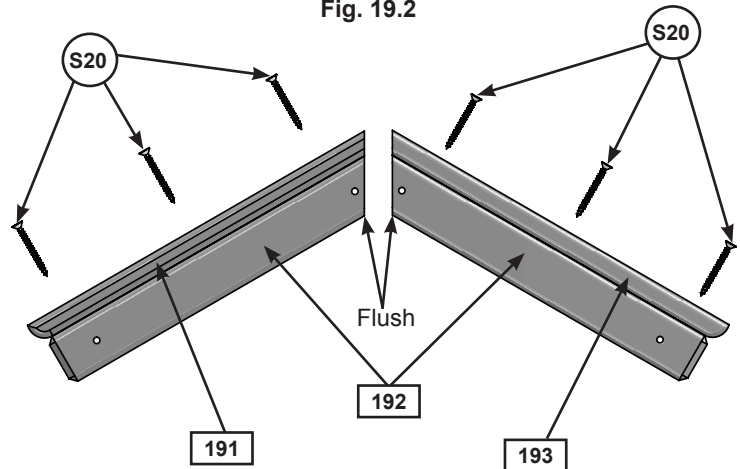

Fig. 19.2



Wood Parts

- 1 x 191 Bell Top 5/8 x 3-3/8 x 11-1/4"
- 2 x 192 Bell Support 1-1/2 x 1-1/2 x 10-5/8"
- 1 x 193 Bell Top RT 5/8 x 3-3/8 x 11-1/4"

Hardware

- 2 x S11 #8 x 2" Wood Screw
- 6 x S20 #8 x 1-3/8" Wood Screw
- 2 x S3 #8 x 2-1/2" Wood Screw

Step 19: Install Bell Assembly Part 2

C: Centred under the peak of the Bell Support Assembly attach Horseshoe Mount to (073) Narrow Front Panel with 4 (S0) #8 x 7/8" Truss Screws. (Fig. 19.3 & 19.4)

D: Thread the Steel Clapper Line through the Bolt. Slide Bell under overhang of Horseshoe Mount then insert Bolt up through Bell and Horseshoe Mount then secure with Nut. Make sure it is tight. (Fig. 19.5 & 19.6)

Fig. 19.3

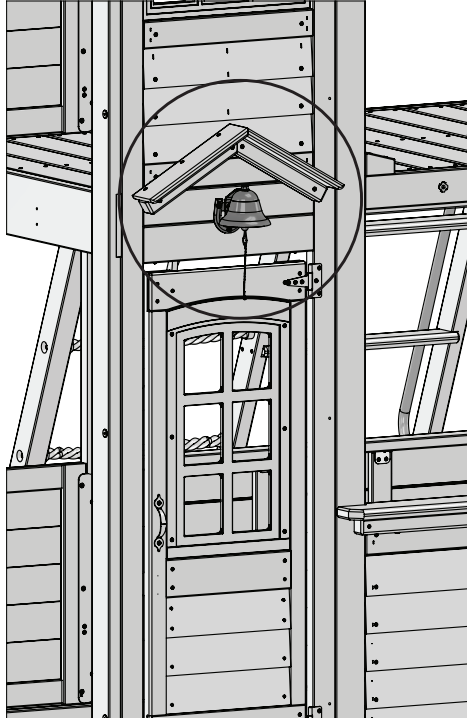

Fig. 19.6

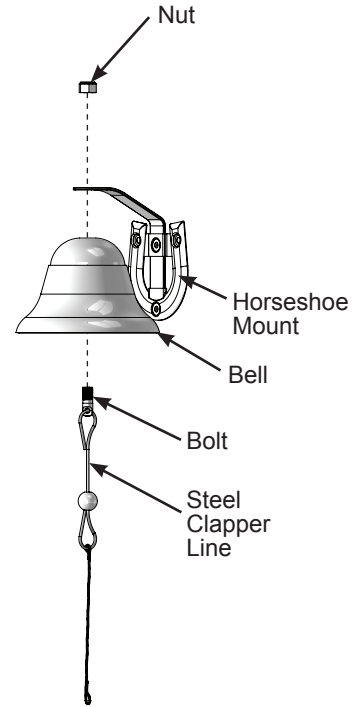

Fig. 19.4

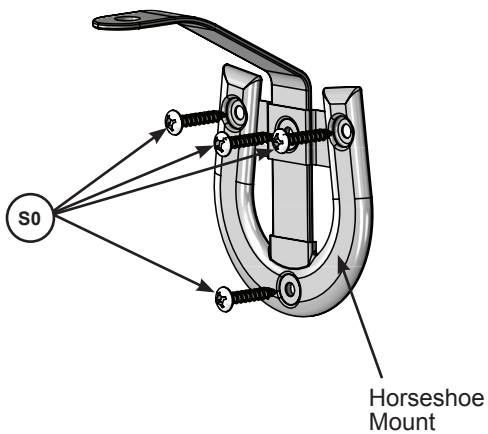
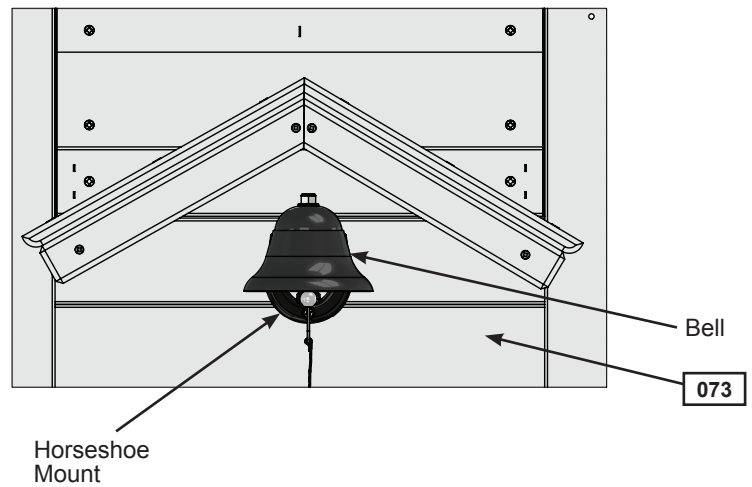

Fig. 19.5



Hardware
4 x (S0) #8 x 7/8" Truss Screw

Other Parts
1 x Horseshoe Bell Set

Step 20: Swing Beam Assembly Part 1



A: Attach 6 Heavy Duty Swing Hangers to (201) Engineered SW Beam using 2 (G13) 5/16 x 6-1/8" Hex Bolt (with 2 flat washers, plastic formed washer and lock nut) per swing hanger, as shown in fig. 20.1 and 20.2.

B: Attach 1 Spring Loaded Quick Link to each Heavy Duty Swing Hanger. (fig. 20.3)

C: Install 1 (WB7) 5/16 x 3" Wafer Bolt (with flat washer and t-nut) in the middle bolt hole, from the bottom up, in (201) Engineered SW Beam as shown in fig. 20.1 and 20.4. **IT IS IMPORTANT THAT THIS BOLT IS ATTACHED. IT WILL MINIMIZE CHECKING OF WOOD.**

D: Attach Cedar Summit / Kidkraft Plaque to centre of (201) Engineered SW Beam (over top of t-nut) using 4 (S38) #7 x 1-1/8" Pan Screws. (fig. 20.5)

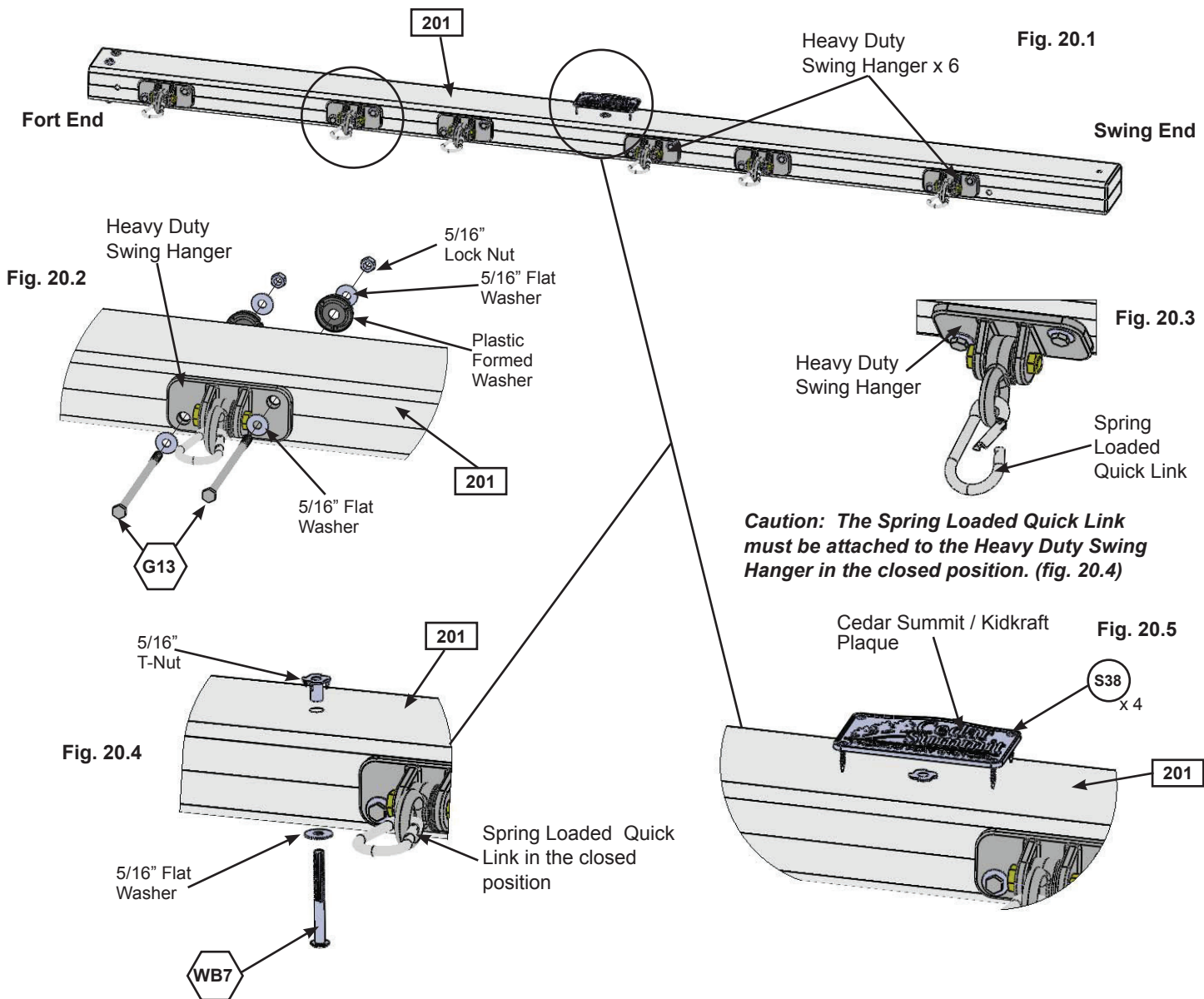

Wood Parts

1 x 201 Engineered SW Beam 3 x 5-1/4 x 92"

Hardware

12 x G13 5/16 x 6-1/8" Hex Bolt
(5/16" flat washer x 2, 5/16" lock nut & plastic formed washer)

1 x WB7 5/16 x 3" Wafer Bolt
(5/16" flat washer, 5/16" t-nut)

4 x S38 #7 x 1-1/8" Pan Screw

Other Parts

6 x Heavy Duty Swing Hangers
6 x Spring Loaded Quick Link
1 x Cedar Summit / Kidkraft Plaque

Step 20: Swing Beam Assembly Part 2

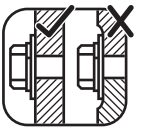

E: On the Fort End of (201) Engineered SW Beam attach 2 Heavy Flat Brackets with 2 (G21) 5/16 x 3-3/4" Hex Bolts (with 2 flat washers and 1 lock nut). (fig. 20.6 and 20.7)

F: Place (202) SW Mount in between both Heavy Flat Brackets and place 1 Heavy L-Bracket against (201) Engineered SW Beam and (202) SW Mount. Attach with 1 (G17) 3/8 x 6" Hex Bolt (with 2 flat washers, plastic formed washer and lock nut). (fig. 20.8)

G: Attach (202) SW Mount to Heavy Flat Brackets with 2 (G21) 5/16 x 3-3/4" Hex Bolts (with 2 flat washers and 1 lock nut). (fig. 20.9)

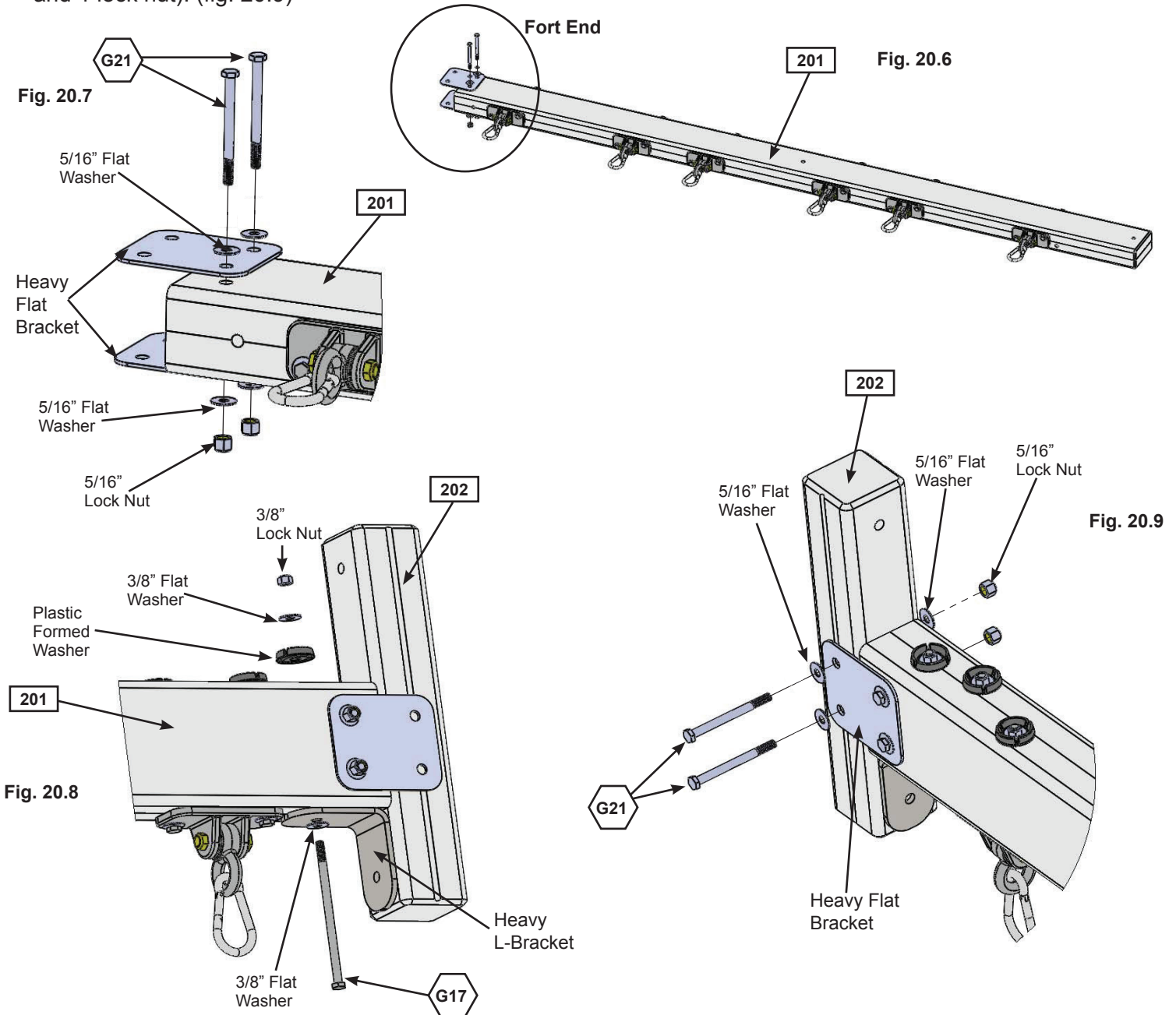

Wood Parts

1 x 202 SW Mount 3 x 3 x 16"

Hardware

4 x G21 5/16 x 3-3/4" Hex Bolt
(5/16" flat washer x 2, 5/16" lock nut)

1 x G17 3/8 x 6" Hex Bolt
(3/8" flat washer x 2, plastic formed washer & 3/8" lock nut)

Other Parts

2 x Heavy Flat Bracket
1 x Heavy L-Bracket

Step 21: Swing Post Assembly Part 1

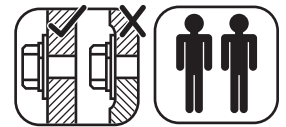

Note: Keep all bolts from Step 21 series loose until start of Step 23

A: Place (211) SW Block Angle on top of (212) Block SW and attach 2 Heavy L-Brackets on top of (211) SW Block Angle feeding 2 (G17) 3/8 x 6" Hex Bolts (with 2 flat washers, plastic formed washer and lock nut) through both boards as shown in fig. 21.1 and 21.2.

B: Attach 3 (WB7) 5/16 x 3" Wafer Bolts (with flat washer and t-nut) to all three holes in each (213) SW Post as shown in fig. 21.3. **IMPORTANT! MAKE SURE ALL 6 BOLTS ARE ATTACHED TO MINIMIZE CHECKING OF WOOD.**

C: Place (211) SW Block Angle and (212) Block SW assembly in between 2 (213) SW Post (Heavy L-Brackets towards the outside). Place 1 Heavy C-Bracket on the top (213) SW Post and attach with (G26) 3/8 x 9-1/4" Hex Bolt (with 2 flat washers and 1 lock nut), as shown in fig. 21.4

Fig. 21.1 Bottom View

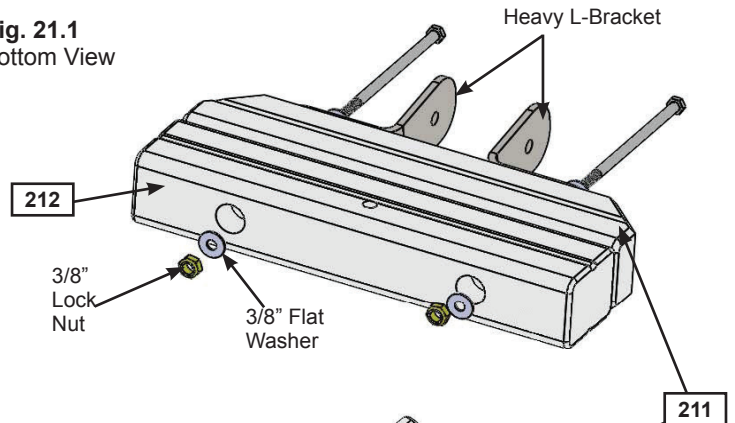

Fig. 21.2 Top View

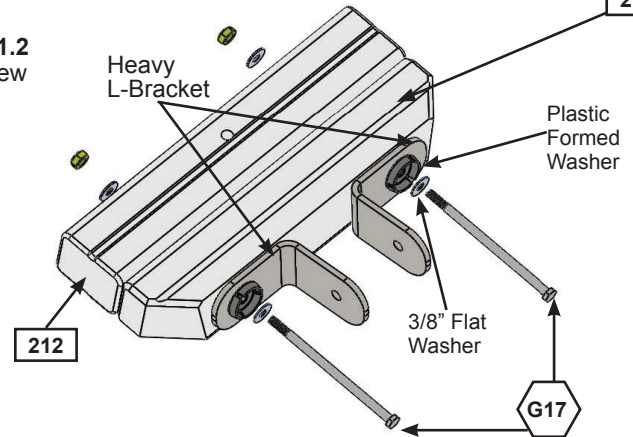

Fig. 21.4

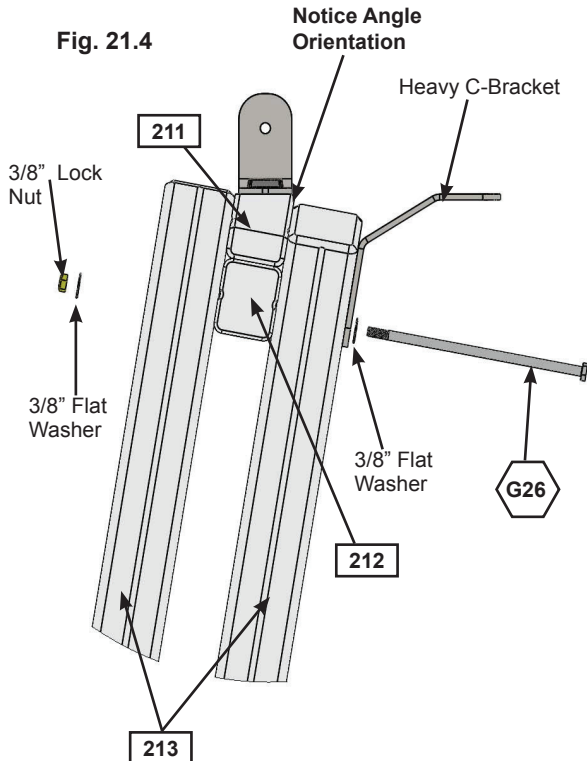
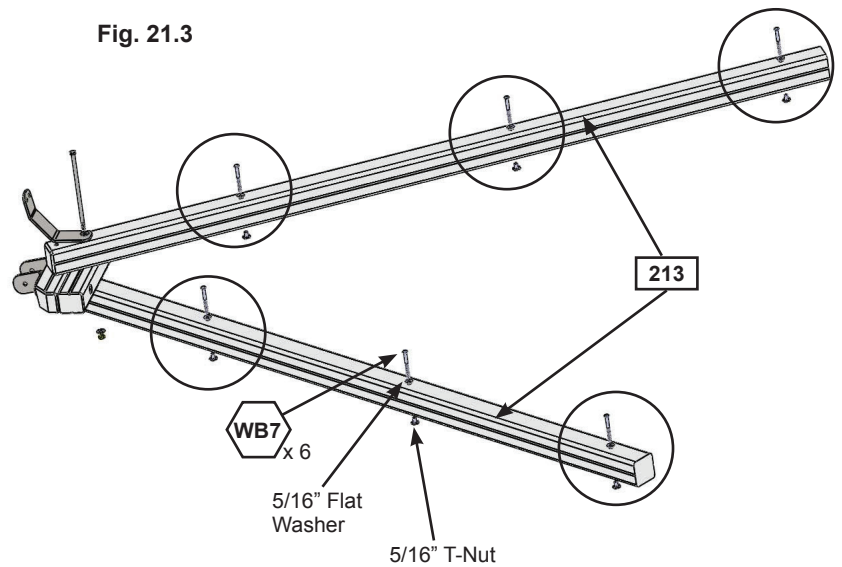

Fig. 21.3



Wood Parts

- 1 x [211] SW Block Angle 2-1/2 x 3 x 15"
- 1 x [212] Block SW 2-1/2 x 3 x 15"
- 2 x [213] SW Post 3 x 3 x 92"

Hardware

- 2 x [G17] 3/8 x 6" Hex Bolt (3/8" flat washer x 2, plastic formed washer & 3/8" lock nut)
- 1 x [G26] 3/8 x 9-1/4" Hex Bolt (3/8" flat washer x 2 & 3/8" lock nut)
- 6 x [WB7] 5/16 x 3" Wafer Bolt (5/16" flat washer & 5/16" t-nut)

Other Parts

- 2 x Heavy L-Bracket
- 1 x Heavy C-Bracket



Step 21: Swing Post Assembly Part 2

D: Place Swing End of (201) Engineered SW Beam in between Heavy L-Brackets assembled in Step A making sure holes are lined up then attach Swing Post Assembly to Swing Beam Assembly using 1 (G20) 3/8 x 4" Hex Bolt (with 2 flat washers and lock nut) through Heavy L-Bracket. (fig. 21.5)

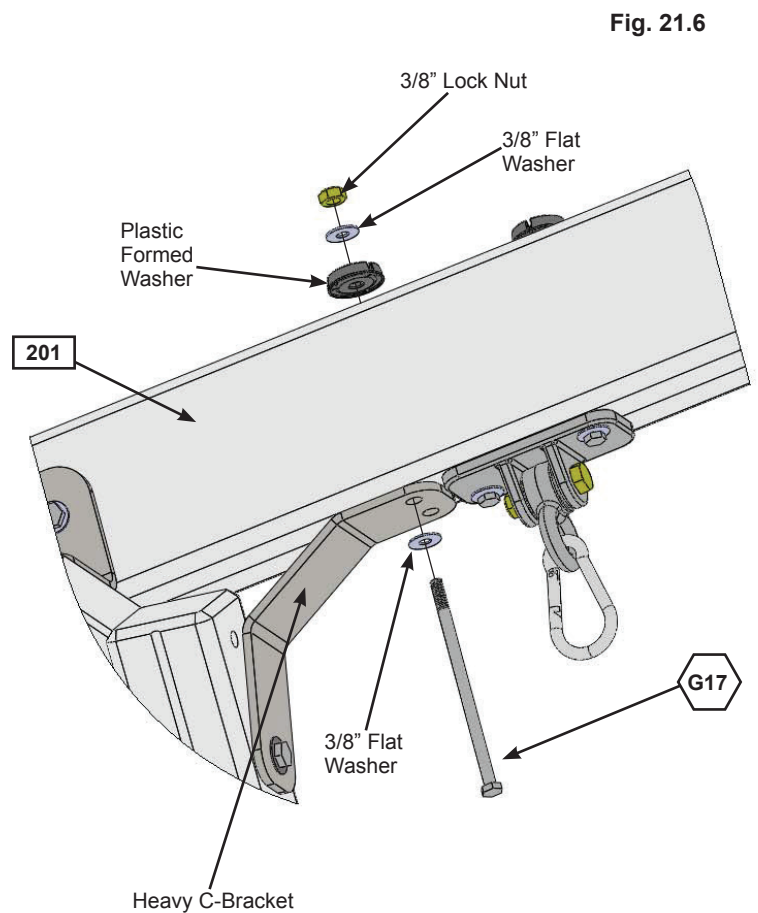
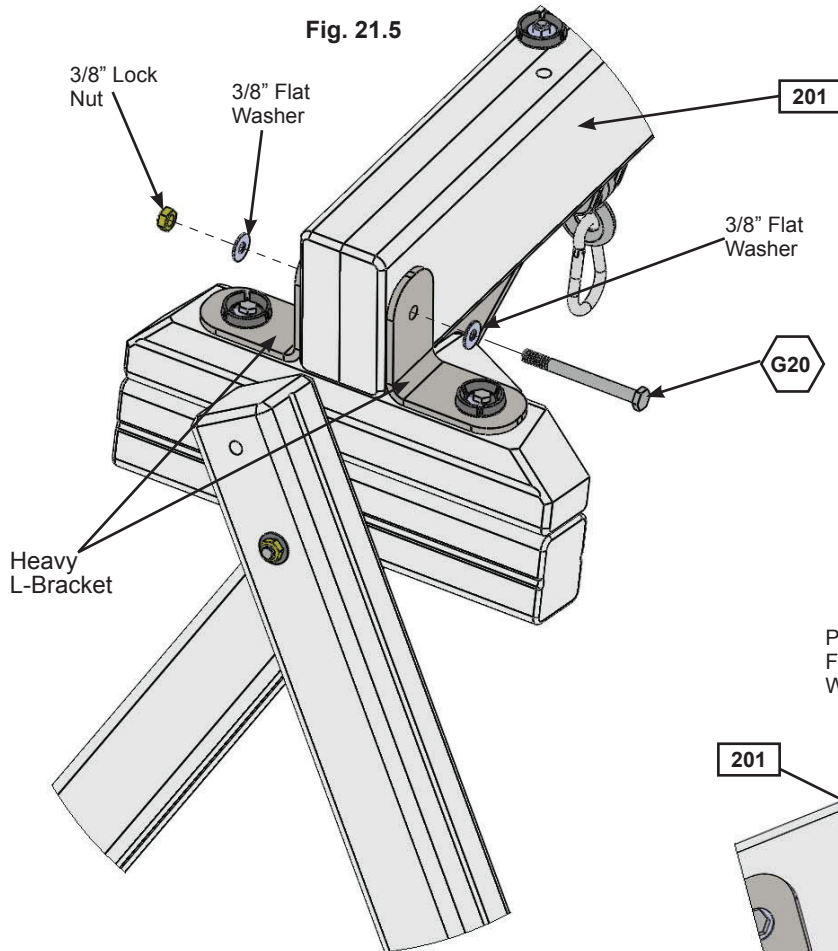
E: Attach (201) Engineered SW Beam to Heavy C-Bracket with 1 (G17) 3/8 x 6" Hex Bolt (with 2 flat washers, plastic formed washer and lock nut). (fig. 21.6)



Hardware

- 1 x  3/8 x 6" Hex Bolt
(3/8" flat washer x 2, plastic formed washer & 3/8" lock nut)
- 1 x  3/8 x 4" Hex Bolt
(3/8" flat washer x 2 & 3/8" lock nut)

Step 21: Swing Post Assembly Part 3

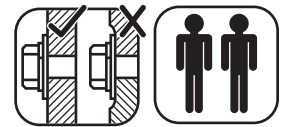

F: Place (202) SW Mount flush to the top of (081) SW Wall Panel. Attach with 1 (G5) 5/16 x 4-1/2" Hex Bolt (with lock washer, flat washer and t-nut) in the bottom hole from outside the assembly and 1 (G5) 5/16 x 4-1/2" Hex Bolt (with 2 x flat washer and 1 lock nut) in the top hole from inside the assembly. (fig. 21.7 and 21.8)

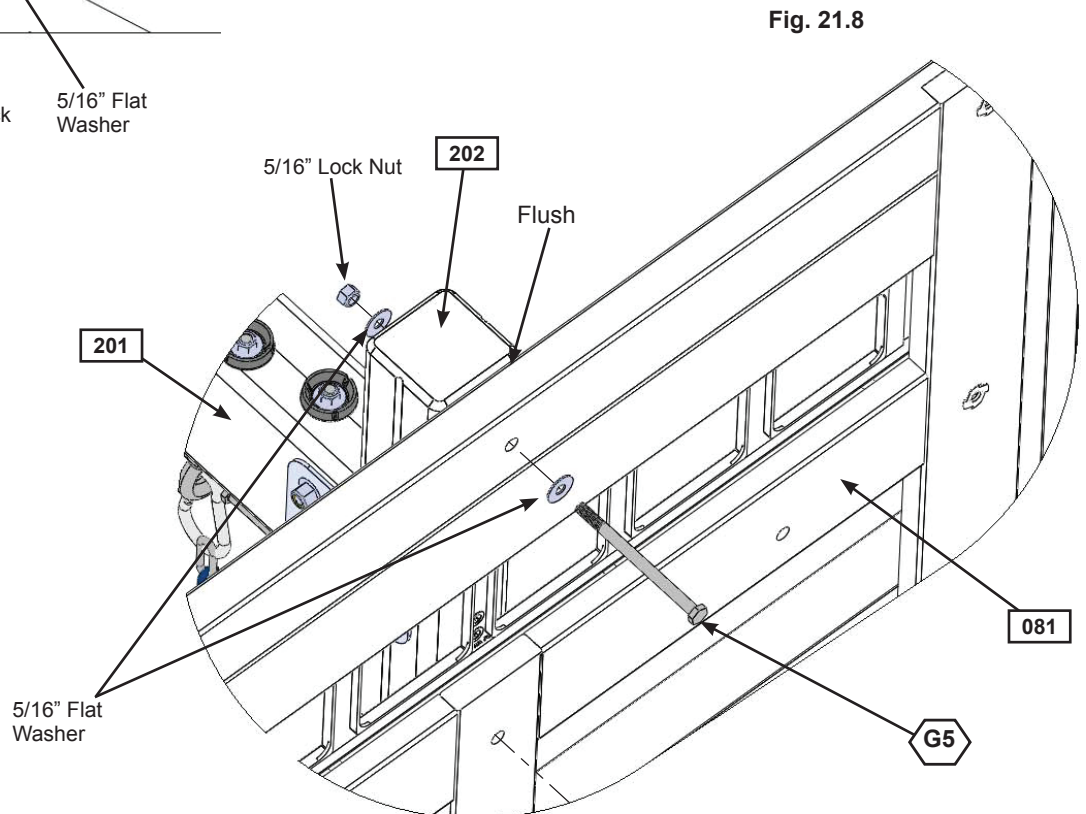
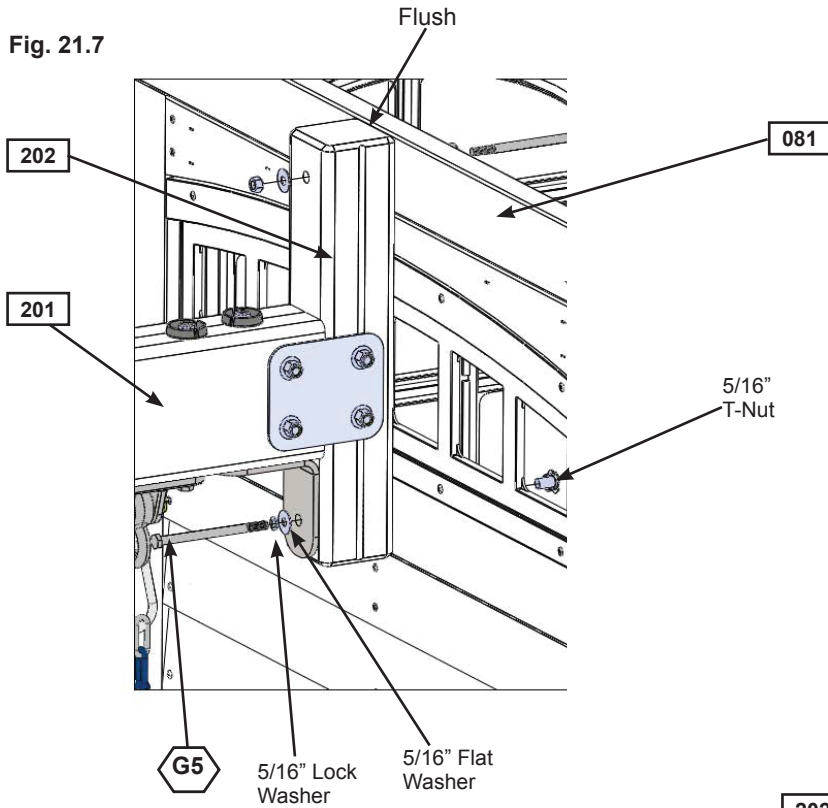

Hardware

- 2 x  5/16 x 4-1/2" Hex Bolt
 (1 - 5/16" lock washer, 5/16" flat washer, 5/16" t-nut)
 (1 - 5/16" flat washer x 2, 5/16" lock nut)

Step 22: Attach Cross Support

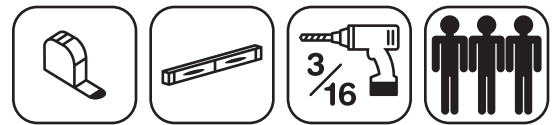

Pre-drill all holes using a 3/16" drill bit before installing the lag screws.

A: To adjust for uneven ground, raise or lower the (221) Support Cross on the (213) SW Post. Make sure the Support Cross is level prior to attaching with the lag screws. (fig. 22.1 and 22.2)

B: Place (221) Support Cross between (213) SW Posts at the previously determined spot and fasten with 1 (LS9) 5/16 x 4-3/4" Lag Screw (with flat washer) per side. (fig. 22.2 and 22.3) **Notice one side is fastened on the outside and one on the inside. It is important that each side is positioned exactly the same as the diagram. (fig. 22.3) Tighten the lag screw when you are sure (221) Support Cross is level.**

C: Attach 1 (WB8) 5/16 x 2-3/8" Wafer Bolt (with flat washer and t-nut) to (221) Support Cross through the middle hole. (fig. 22.2 and 22.3) **IMPORTANT! MAKE SURE THE BOLT IS ATTACHED TO MINIMIZE CHECKING OF WOOD.**

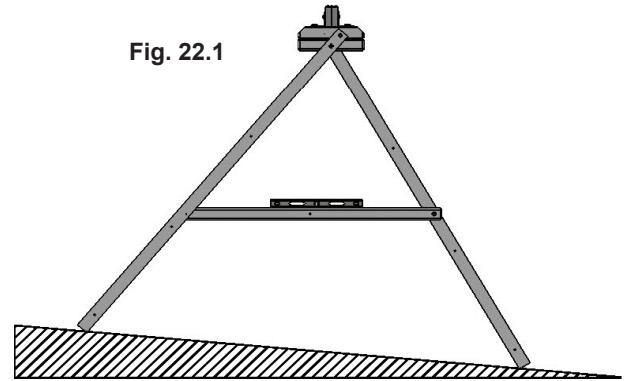

Fig. 22.1

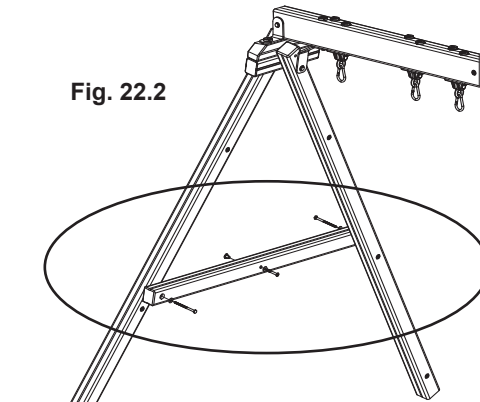

Fig. 22.2

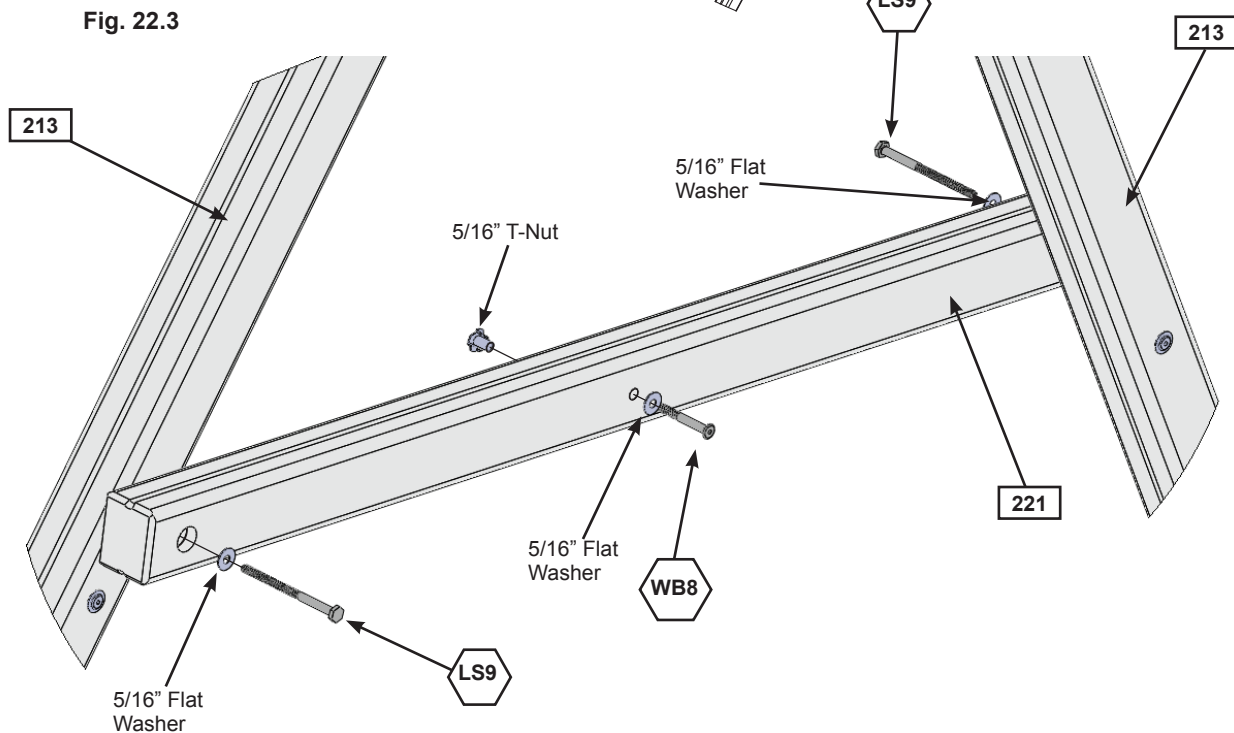

Fig. 22.3

Wood Parts

1 x [221] Support Cross 2-1/2 x 3 x 51"

Hardware

2 x [LS9] 5/16 x 4-3/4" Lag Screw (5/16" flat washer)

1 x [WB8] 5/16 x 2-3/8" Wafer Bolt (5/16" flat washer, 5/16" t-nut)

Step 23: Final Swing Post Assembly

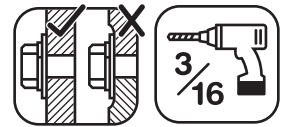

Pre-drill all holes using a 3/16" drill bit before installing the lag screws.

Note: Tighten all bolts from Step 21 series before installing lag screws.

A: Attach 1 (LS9) 5/16 x 4-3/4" Lag Screw (with flat washer) into each (213) SW Post, as shown in fig. 23.1.

B: Attach 1 (LS9) 5/16 x 4-3/4" Lag Screw (with flat washer) into remaining hole of the Heavy C-Bracket into (201) Engineered SW Beam. (fig. 23.1)

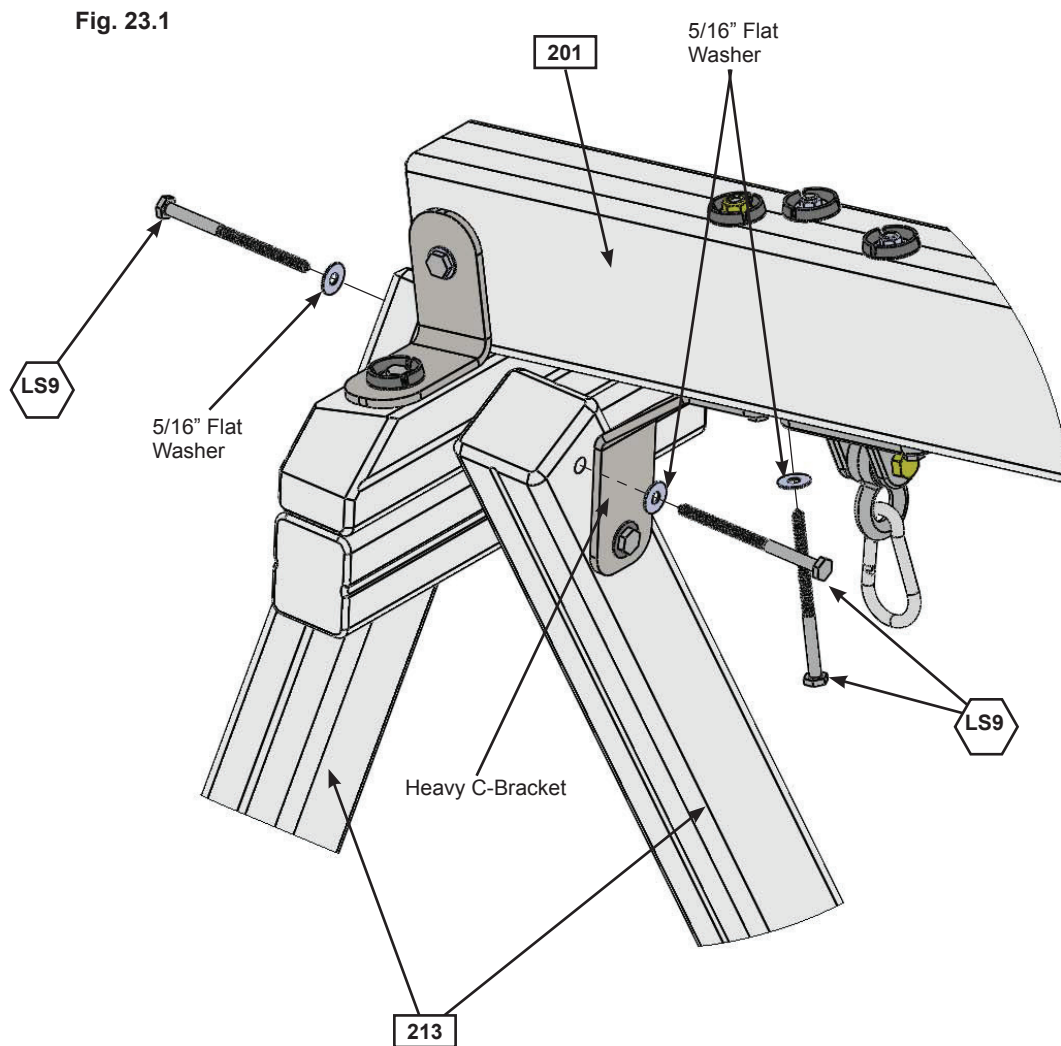

Hardware

3 x  5/16 x 4-3/4" Lag Screw
(5/16" flat washer)

Step 24: Install Ground Stakes

MOVE FORT TO FINAL LOCATION PRIOR TO STAKING **FINAL LOCATION MUST BE LEVEL GROUND**

A: In the 5 places shown in fig. 24.1 drive the Rebar Ground Stakes 13" into the ground against (142) Diagonal, (072) Narrow Back Panel, (021) Left Access and both (213) SW Posts. Be careful not to hit the washer while hammering stakes into the ground as this could cause the washer to break off.

B: Attach ground stakes using 1 (S7) #12 x 2" Pan Screw per ground stake as shown in fig. 24.2.

C: After driving stakes into the ground, check for sharp edges caused by the impact of the hammer. Smooth any sharp edges from impact area and touch up with outdoor paint.

⚠ Warning! To prevent tipping and avoid potential injury, stakes must be driven 13" into ground. Digging or driving stakes can be dangerous if you do not check first for under-ground wiring, cables or gas lines.

Fig. 24.1

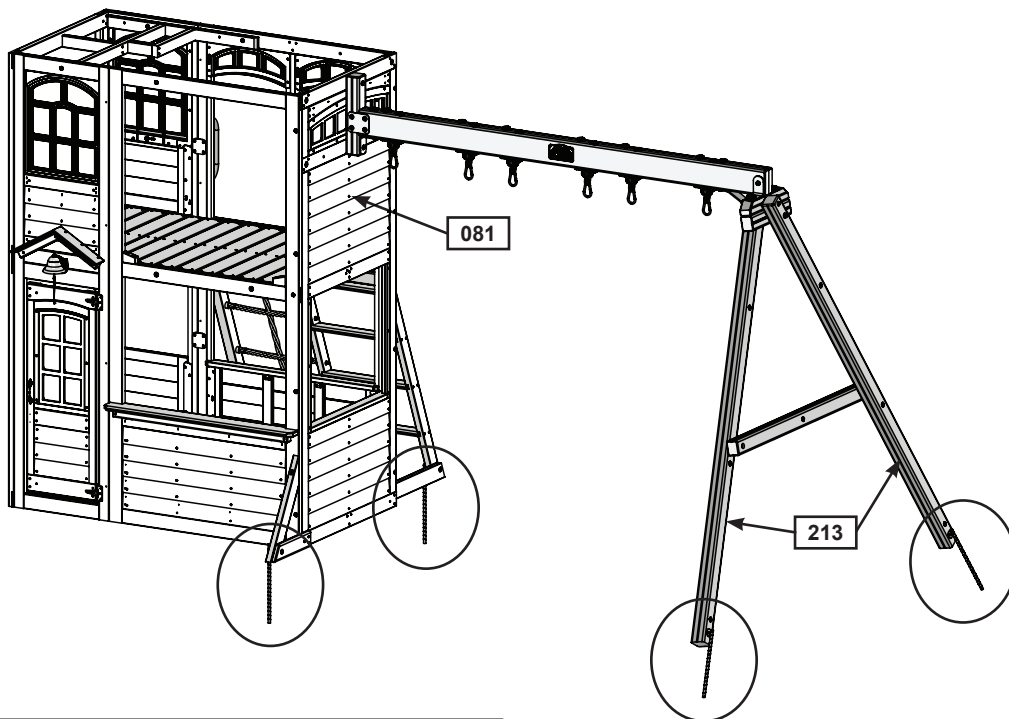
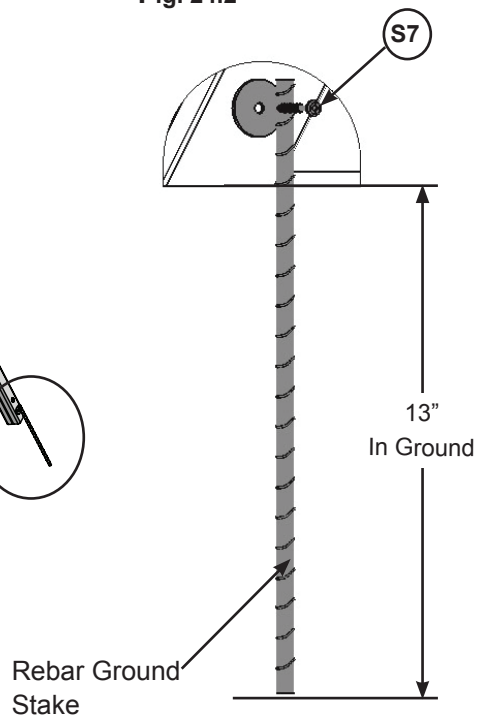

Fig. 24.2



**SEE FRONT COVER FOR
SAFETY CLEARANCE**

Hardware

5 x (S7) #12 x 2" Pan Screw

Other Parts

5 x Rebar Ground Stake

Step 25: Roof Support Assemblies

A: Attach 1 (251) Roof Support to a second (251) Roof Support at peak using 1 (S4) #8 x 3" Wood Screw. Repeat this step to make 2 Roof Support Assemblies. (fig. 25.1)

Fig. 25.1

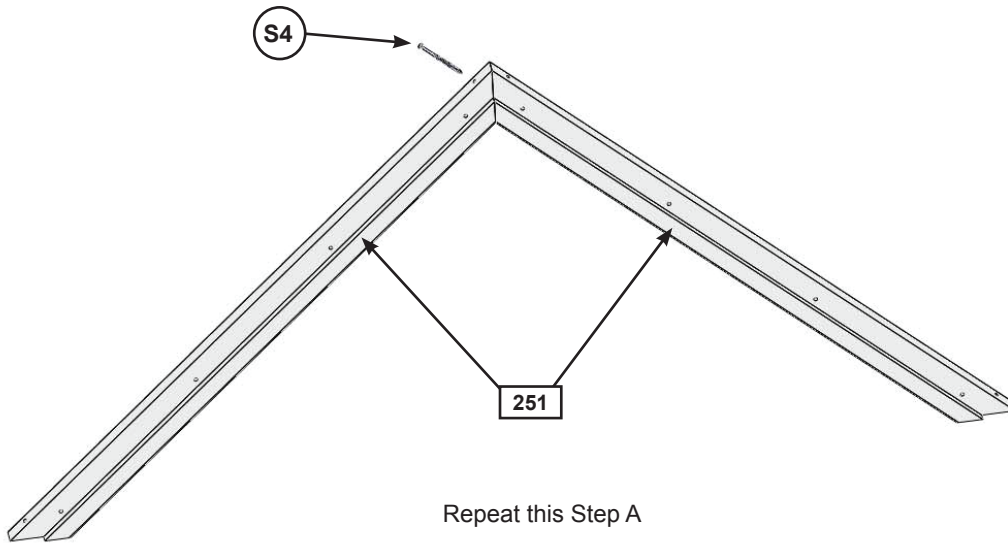

Wood Parts

4 x 251 Roof Support 1-1/4 x 2-1/4 x 33"

Hardware

2 x S4 #8 x 3" Wood Screw