

16817



Call Us First!

DO NOT RETURN TO STORE.

**For immediate help with assembly or product information
call our toll-free number:**

1-888-827-9056

or email:

customerservice@backyardproductsllc.com

Our staff is ready to provide assistance.

April through October M - F 8:00 AM to 7:00 PM EST

Saturday 8:30 AM to 4:30 PM EST

November through March M - F 8:00 AM to 5:00 PM EST

(This page is intentionally left blank.)

Customer Service
1-888-827-9056
1000 Ternes Drive
Monroe, MI 48162

16817

11/29/2013

ASSEMBLY MANUAL

GAMBREL SHED 10' x 8' (305 x 244 cm)

Includes 10' x 8' Building Instruction

KEEP THIS MANUAL FOR FUTURE REFERENCE

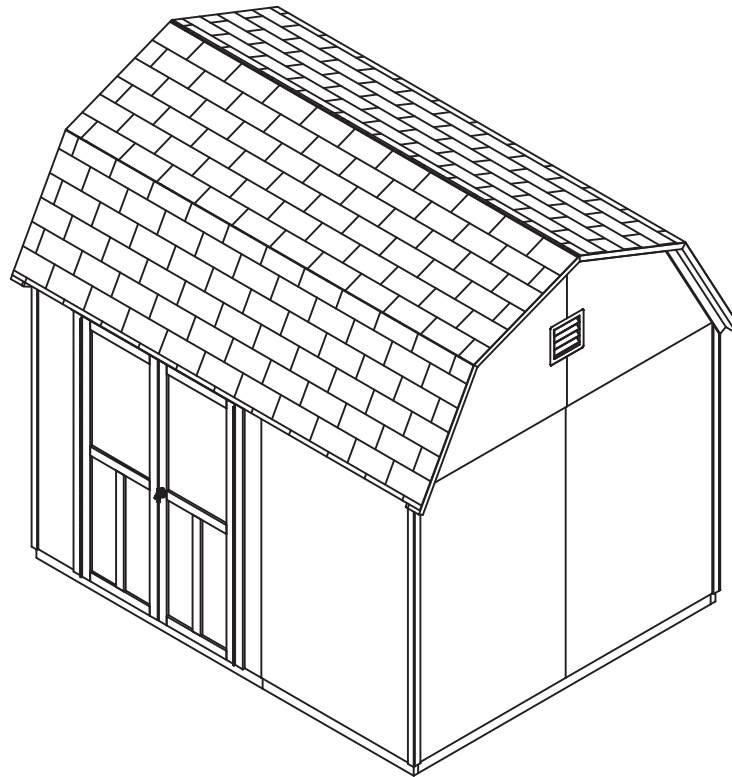

IMPORTANT! READ INSTRUCTIONS THOROUGHLY PRIOR TO BEGINNING ASSEMBLY.



BEFORE YOU BEGIN

- **BUILDING RESTRICTIONS AND APPROVALS**

Be sure to check local building department and homeowners association for specific restrictions and/or requirements before building.

- **ENGINEERED DRAWINGS**

Contact our Customer Service Team if engineered drawings are needed to pull local permits.

- **SURFACE PREPARATION**

To ensure proper assembly you must build your shed on a level surface. Recommended methods and materials to level your shed are listed on page 7.

- **CHECK ALL PARTS**

Inventory all parts listed on pages 4-6. Contact our Customer Service Team if any parts are missing or damaged.

- **ADDITIONAL MATERIALS**







You will need additional materials to complete your shed. See page 3 for required and optional materials and quantities.





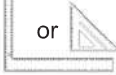
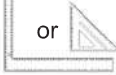

- CUSTOMER SERVICE -

Call: 1-888-827-9056 email: customerservice@backyardproductsllc.com

TOOLS

Required

- Phillips Screwdriver 
- Drill / Driver
 - Drill Bit
 - #2 philips Drive Bit
- Hammer 
- Pencil 
- Tape Measure 
- Square  or 
- Level 

- Chalk Line 
- Utility Knife
 - Shingle Blades 
- Caulk Gun 
- Exterior rated Wood Glue 
- Ladder 
- Paint Tools 

Optional

- Tool Belt/ Nail Pouch 
- Safety Glasses 
- Nail Gun
 - Gun Nails 
- Gloves 
- Clamps 

Safety! Always use approved safety glasses during assembly.

HELPFUL REMINDER SYMBOLS

Look for these symbols for helpful reminders throughout this manual.



= Assistance Required; two or more people.



= Mark part with pencil.



= Ensure squareness.



= Beginning of steps for assembly or installation.



= Important required step or operation.



= Helpful assembly hint.



= Level

ORIENT LUMBER AND TRIM FOR BEST APPEARANCE

Framing lumber is graded for structural strength and not appearance. Exterior trim is graded for one good side.

Always install the material leaving the best edge and best surface visible. Please remember that these blemishes in no way negatively affect the strength or integrity of our product. (See Fig A, B, C.)

A

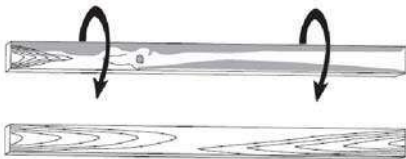

B

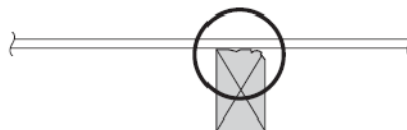

C

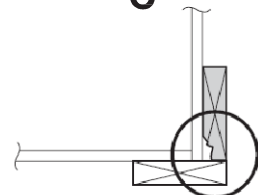

ADDITIONAL MATERIALS

FOUNDATION OR FLOOR MATERIALS

- This kit does not contain a floor frame, or floor decking.
- No leveling materials are included with the shed kit.
- See the **FLOOR LEVELING** section on page 7 for recommended methods and suggested materials to properly level your floor, as this will vary depending on your specific site.

REINFORCED WOOD FLOOR FRAME (OPTIONAL)

IMPORTANT! Depending on your specific use you may want to construct a heavy duty floor frame by adding additional floor joists (shown below as shaded). Below is a list of additional materials that are not included in our standard floor kit.

- x2** 2 x 4 x 8' (5,1 x 10,2 x 243,8 cm) Treated Lumber
Cut lumber to 2 x 4 x 93" (5.1 x 10,2 x 236,2 cm)
Treated Lumber

- x8** ea. 3" (7,6 cm) hot dipped galvanized nails

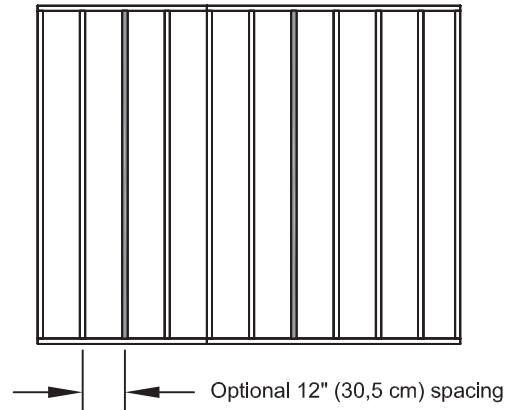

COMPLETING YOUR SHED

You will need these additional materials:

- | | |
|--|--|
| <input type="checkbox"/> 3-TAB SHINGLES.....6 Bundles | <input type="checkbox"/> 1" GALVANIZED ROOFINGNAILS...3LBS
For Shingles. |
| <input type="checkbox"/> PAINT FOR SIDING.....2 Gallons
Use 100% acrylic latex exterior paint. (2) coats recommended. | <input type="checkbox"/> PAINT FOR TRIM.....1 Quart
Use 100% acrylic latex exterior paint. |
| <input type="checkbox"/> CAULK.....2 Tubes
Use acrylic latex exterior caulk that is paintable.  | <input type="checkbox"/> WOOD GLUE.....Exterior Rated |

OPTIONAL MATERIALS

- | | |
|---|---|
| <input type="checkbox"/> DRIP EDGE.....30 Feet | <input type="checkbox"/> #15 ROOFING FELT
To cover 130 Sq. Ft. of roof area |
| | <input type="checkbox"/> 1" GALVANIZED ROOFING NAILS...1/4 Lb
For roofing felt. |

REFER TO THE BACK OF THIS MANUEL AND THE MANUFACTURER'S INSTRUCTIONS FOR INSTALLATION OF SHINGLES, DRIP EDGE AND FELT.

PARTS IDENTIFICATION AND SIZES

Part Identification is stamped on some parts.

Treated lumber is stamped:

WOOD SIZE CONVERSION CHART

Nominal Board Size	Actual Size
2" x 4".....	1-1/2" x 3-1/2" (3,8 x 8,9 cm)
1" x 4".....	3/4" x 3-1/2" (1,9 x 8,9 cm)
2" x 3".....	1-1/2" x 2-1/2" (3,8 x 6,3 cm)
1" x 3".....	3/4" x 2-1/2" (1,9 x 6,3 cm)

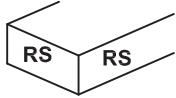

TREATED

- Check these locations for Part stamps

PARTS LIST



INVENTORY YOUR PARTS before you begin.

We suggest sorting parts by the category they are listed in.

WALLS

- X2 **ABA** 2 x 4 x 20" (5,1 x 10,2 x 50,8 cm)
- X2 **SL** 2 x 4 x 36" (5,1 x 10,2 x 91,4 cm)
- X3 **RL** 2 x 4 x 24" (5,1 x 10,2 x 61 cm)
- X4 **SL** 2 x 4 x 36" (5,1 x 10,2 x 91,4 cm)
- X1 **QU** 2 x 4 x 56" (5,1 x 10,2 x 142,2 cm)
- X13 **TM** 2 x 4 x 72" (5,1 x 10,2 x 82,9 cm)
- X2 **SZ** 2 x 4 x 89" (5,1 x 10,2 x 226,1 cm)
- X2 **AQA** 2 x 4 x 93" (5,1 x 10,2 x 236,2 cm)
- X3 **TP** 2 x 4 x 96" (5,1 x 10,2 x 243,8 cm)

ROOF

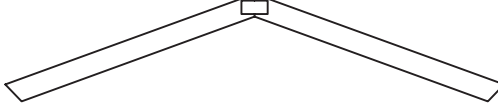
- X10  6 x 24" (15,2 x 61 cm)
- X12  **SUB-ASSEMBLED TRUSS**
- X2 **WO** 1 x 4 x 72" (2,5 x 10,2 x 182,9 cm)

TRIM

- X4 3/8 x 1-3/4 x 9-5/8" (1 x 4,4 x 24,4 cm)
- X4 3/8 x 1-3/4 x 13-1/8" (1 x 4,4 x 33,3 cm)
- X2 3/8 x 4-1/2 x 22" (1 x 11,4 x 55,9 cm)
- X4 **ISDA** ⊖ 2 x 4 x 36-1/8" (5,1 x 10,2 x 91,8 cm)
- X2 **ZIR** 19/32 x 3-1/2 x 36-1/8" (1,5 x 8,9 x 91,8 cm)
- X2 **ZIL** 19/32 x 3-1/2 x 36-1/8" (1,5 x 8,9 x 91,8 cm)
- X4 **ISCA** ⊖ 2 x 4 x 36-15/16" (5,1 x 10,2 x 93,8 cm)
- X2 **ZLR** 19/32 x 3-1/2 x 36-15/16" (1,5 x 8,9 x 93,8 cm)
- X2 **ZLL** 19/32 x 3-1/2 x 36-15/16" (1,5 x 8,9 x 93,8 cm)
- X1 3/8 x 2-1/2" x 55" (1 x 6,4 x 139,7 cm)
- X4 3/8 x 1-3/4 x 75" (5,1 x 4,2 x 190,5 cm)
- X4 3/8 x 1-3/4 x 76-1/2" (1,5 x 4,4 x 194,3 cm)
- X2 3/8 x 4-1/2 x 96" (1 x 11,4 x 243,8 cm)

- X1 **GAA** 1 x 3 x 5" (2,5 x 7,6 x 12,7 cm)
Gauge Block for 3/4" (1,9 cm) measurement.

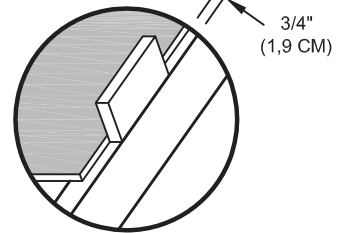

DOOR

- X2 **BEA** 19/32 x 2-1/2 x 19" (1,5 x 6,4 x 48,3 cm) **DOOR RAILS**
- X2 **UWA** 19/32 x 2-1/2 x 32" (1,5 x 6,4 x 81,3 cm) **DOOR RAILS**
- X2 **TCA** 2 x 4 x 51" (5,1 x 10,2 x 129,5 cm)
- X2 **YFA** 2 x 4 x 68-1/2" (5,1 x 10,2 x 174 cm)
- X2 **OO** 2 x 3 x 69" (5,1 x 7,6 x 175,3 cm)

WALL PANEL & DOOR PARTS LIST

NOTE: Panel parts are not stamped with part identification.

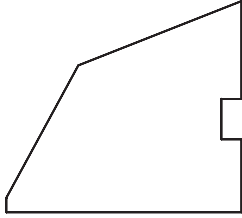

x2
3/8 x 43-1/16 x 48"
(1 x 109,4 x 121,9 cm)

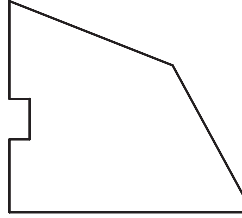

x2
3/8 x 43-1/16 x 48"
(1 x 109,4 x 121,9 cm)



x1
3/8 x 4 x 48"
(1 x 10,2 x 121,9 cm)



x1
3/8 x 15-7/8 x 76"
(1 x 40,3 x 193 cm)

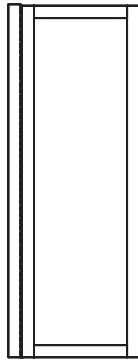

x1
LEFT DOOR

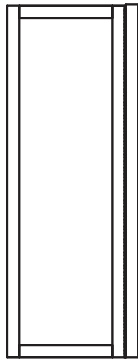

x1
RIGHT DOOR

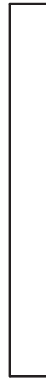

x1
3/8 x 7-7/8 x 76"
(1 x 20 x 193 cm)

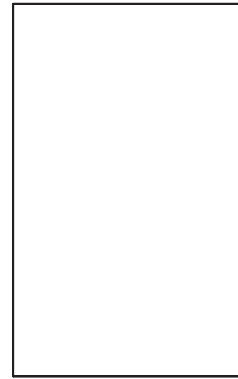

x7
3/8 x 48 x 76"
(1 x 121,9 x 193 cm)

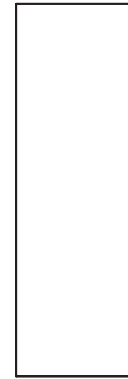

x1
3/8 x 23-7/8 x 76"
(1 x 60,6 x 193 cm)

ROOF PANELS



x2
7/16 x 35-7/8 x 96"
(1,1 x 81,1 x 243,8 cm)



x2
7/16 x 23-7/8 x 35-7/8"
(1,1 x 60,3 x 81,1 cm)



x2
7/16 x 23-7/8 x 96"
(1,1 x 60,6 x 243,8 cm)



x4
7/16 x 11-7/8 x 24-11/16"
(1,1 x 30,2 x 62,7 cm)



x2
7/16 x 11-7/8 x 72"
(1,1 x 30,2 x 182,9 cm)



x2
7/16 x 23-7/8 x 23-7/8"
(1,1 x 60,3 x 60,3 cm)



x1
7/16 x 2-1/2 x 48"
(1,1 x 6,4 x 121,9 cm)
(Header Filler)

Roof panels are 7/16" (1,1 cm) thick.

DOOR & VENT HARDWARE (Not actual size)

T-HANDLE
 x1

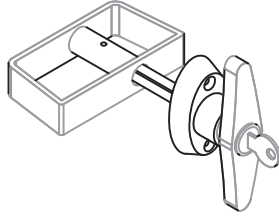

VENT
 x2



x2

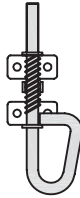

x8



1" (2,5 cm)
 Included with barrel bolt

NAIL BOXES

x2 BOXES



x4 BOXES



FASTENER/HARDWARE BAG

x80



x165



x60



x48

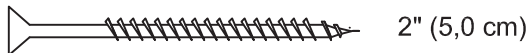

x2



x70



NOTES

There are multiple ways to level your floor frame. Our recommended leveling method is shown below. Leveling materials are not included in this kit.

PREFERRED METHOD - 4 X 4 TREATED RUNNERS

- 3" (7,6 cm) Screws angled into 4 x 4.
- (2) at each point frame and 4 x 4 touch.

Measurements to centers of 4x4's.

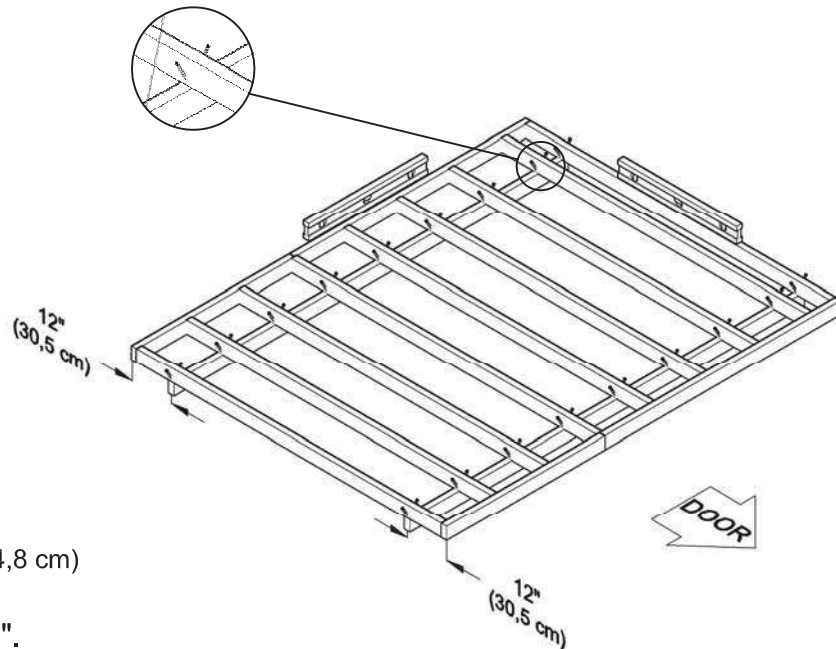

MATERIAL REQUIRED

x2 4" x 4" x 10' (10,2 x 10,2 x 304,8 cm) Treated Lumber

Fasteners for Frame to 4" x 4".

(3"(7,6 cm) Screws shown as one option.) Minimum (36) 3" (7,6 cm) screws / exterior grade.

Use only wood treated for ground contact and fasteners approved for use with treated wood.

Always support frame seams.

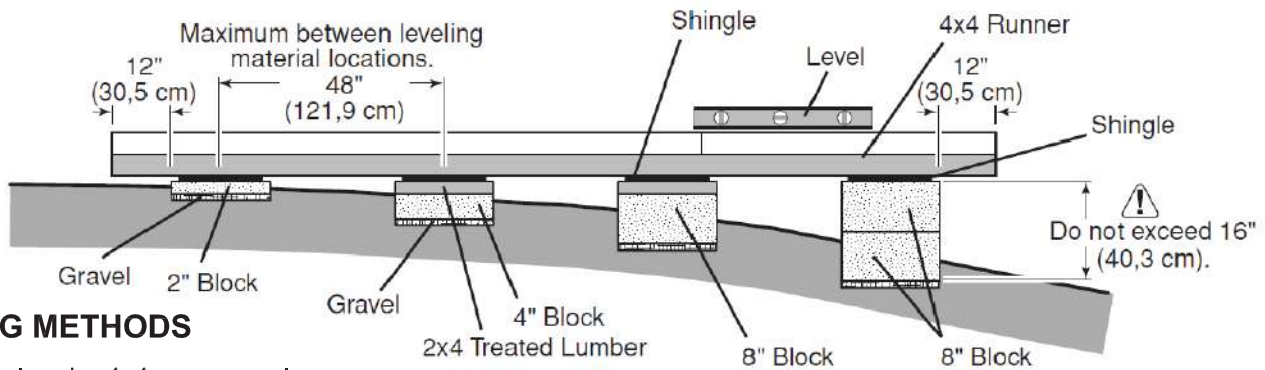

LEVELING METHODS

- Level under 4x4 runners only.
- Locate leveling material 12" (30,5 cm) from ends of runners and no more than 48" (121,9 cm) apart.
- Asphalt shingles should be used between 4x4 runners and blocks or treated lumber. Never use shingles in direct contact with ground.
- For best results and aiding in water drainage use gravel under each concrete block.

MATERIAL REQUIRED

Gravel

Solid Masonry Blocks in 1", 2", 4" or 8" thickness

2x4 Treated Lumber

Asphalt Shingles

Leveling higher than 16" (40,3 cm) is not recommended.

CONCRETE

- If you are building your shed on concrete foundation see following page.

CONCRETE FOUNDATION

If you choose to install your kit on a concrete slab refer to the diagram below.

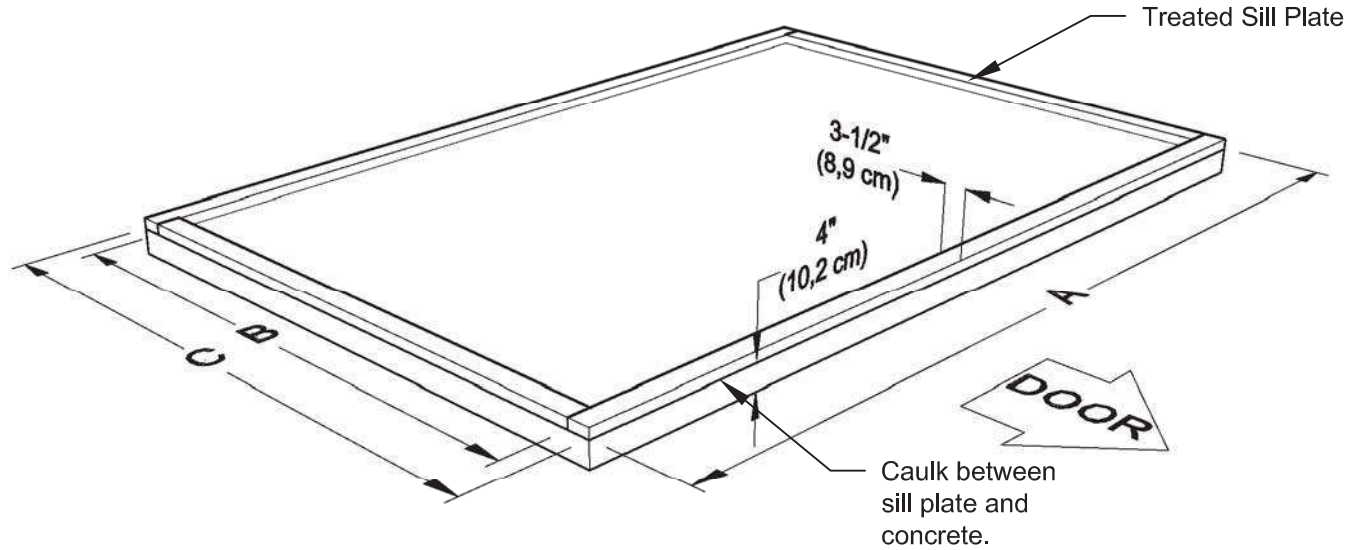

Building Size	Actual Size	A	B	C
10' x 8' (304,8 x 243,8 cm)	120" x 96" (304,8 x 243,8 cm)	120" (304,8 cm)	89" (226,1 cm)	96" (243,8 cm)

Requires:

- x2 2" x 4" x 10' (2,1 x 10,2 x 304,8 cm) ⚠
- x2 2" x 4" x 8' (2,1 x 10,2 x 243,8 cm) ⚠
- x1 Caulk

MUST be treated lumber.

MUST be treated lumber.

⚠ Allow new concrete slabs to cure for at least (7) days.

- A treated 2 x 4" (5,1 x 10,2 cm) sill plate is required when installing your shed on concrete.
- Use a high quality exterior grade caulk beneath all sill plates.
- Fasten 2 x 4" (5,1 x 10,2 cm) sill plates to slab using approved concrete anchors (**fasteners not included**).
- Check local code for concrete foundation requirements.

WOOD FLOOR FRAME (NOT INCLUDED)

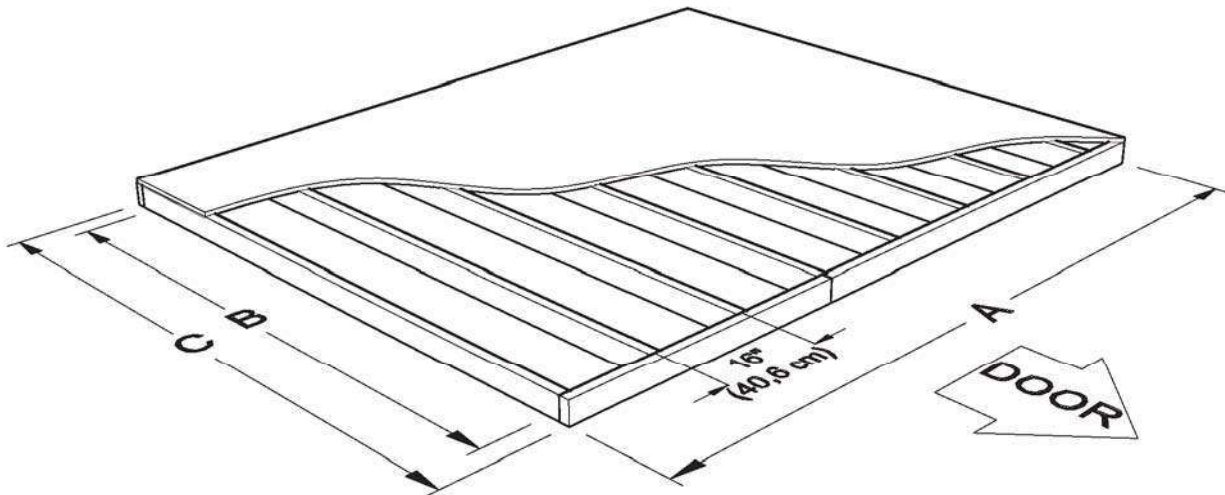

Building Size	Actual Size	A	B	C
10' x 8' (304,8 x 243,8 cm)	120" x 96" (304,8 x 243,8 cm)	120" (304,8 cm)	89" (226,1 cm)	96" (243,8 cm)

FLOOR FRAME

STOP!



LEVEL AND SQUARE FLOOR FRAME



STOP!

Before attaching floor decking, it is important to level and square the floor frame. A level and square floor frame is required to correctly construct your shed.



Begin

- 1) See page 7 for the preferred floor leveling method.
- 2) Use level and check the frame is level before applying floor panels
- 3) Check for frame squareness by measuring diagonally across the corners. If the measurements are the same, the frame is square. the diagonal measurement will be approximately 153-5/8" (390,3 cm).
- 4) When the frame is level at ends of each runner. Move to the opposite end of the frame. Secure the frame to 4x4 runners with one fastener at ends of each runner making sure the frame remains square **(Fig. A)**.
- 5) Once the floor is level and square fasten the frame at each point the frame contacts the 4x4 runners.

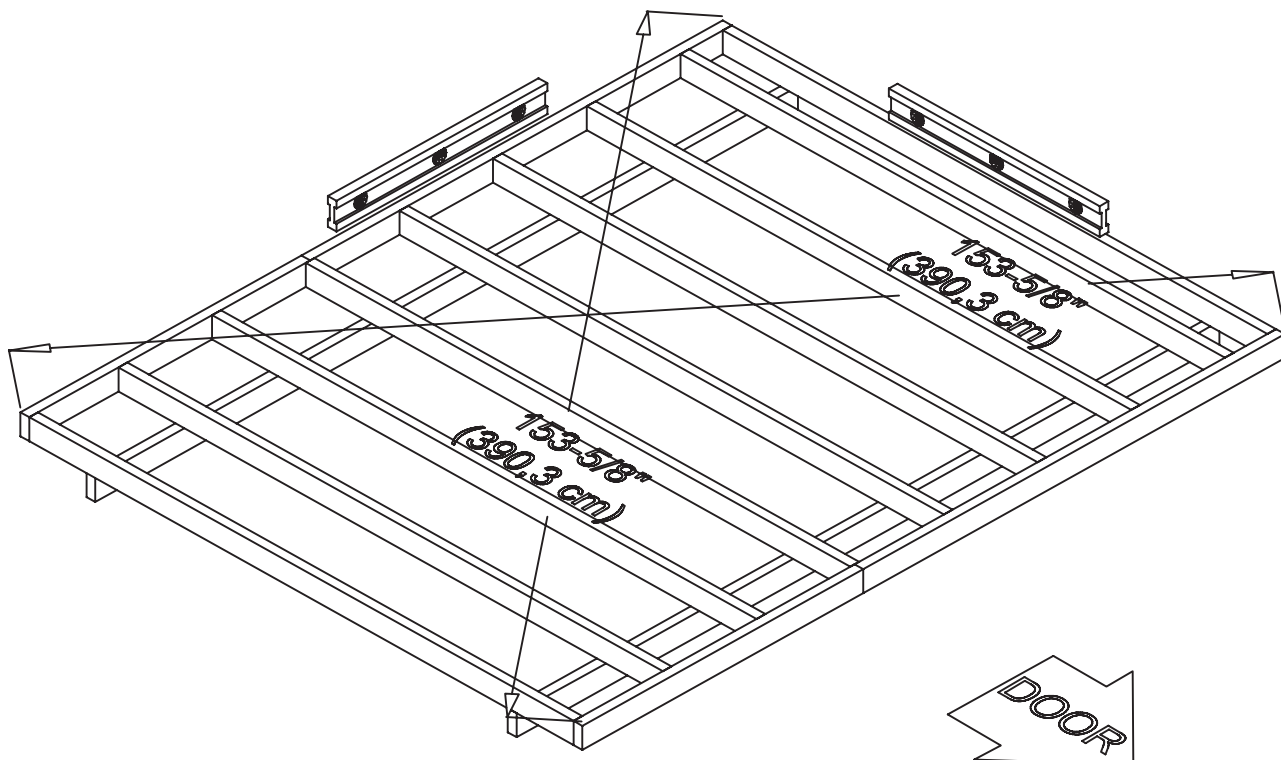



IMPORTANT!



Check the floor frame is level after installing floor panels. Re-level if needed.

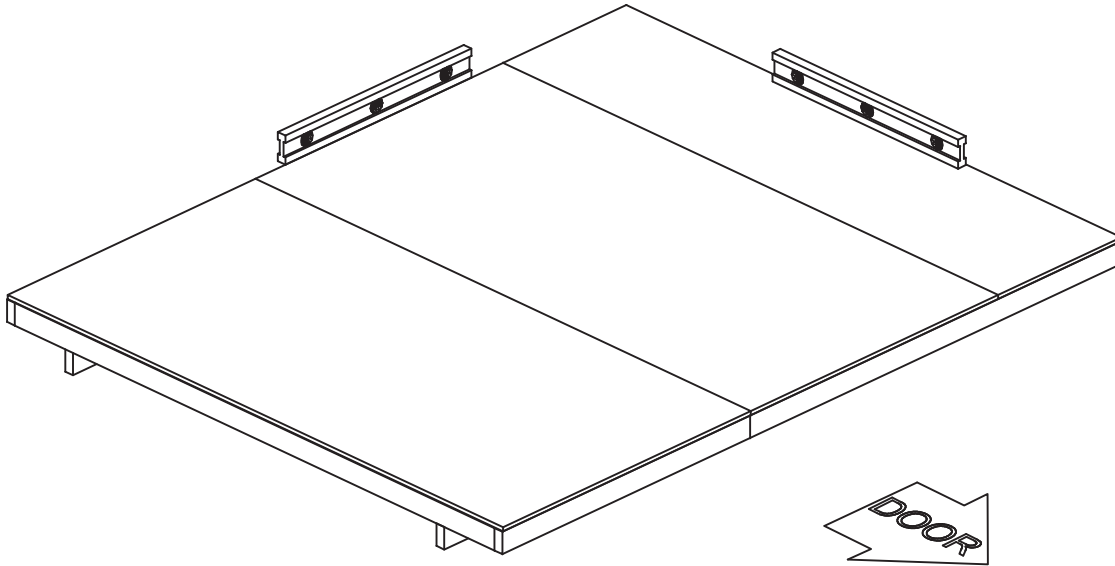

- The floor should be used as a stable work surface for wall construction.
- Organize your assembly procedure during the build process to avoid over-handling of the walls

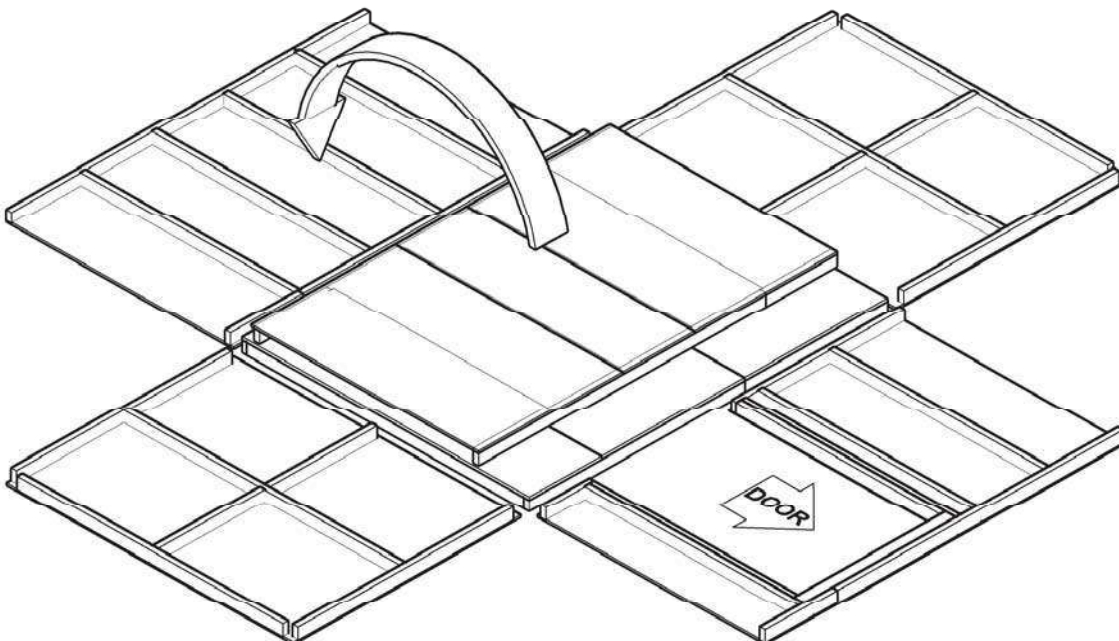

SIDE WALL

Parts Required:

X2	2 x 4 x 93"	AQA
X2	2 x 4 x 89"	SZ
X4	2 x 4 x 72"	TM
X4	2 x 4 x 36"	SL

Fasteners Required:

X16	3" Nails
X4	3" Screws

ASSEMBLY STEPS / NOTES:

!! YOU WILL BUILD TWO SIDE WALLS THE SAME !!

1. Orient parts on edge on floor as shown. Measure and mark. Attach upper part **SL** to **SZ** first.
2. Nail using two 3" nails at each connection. Except at center connection of lower **SL** - use 3" screws.

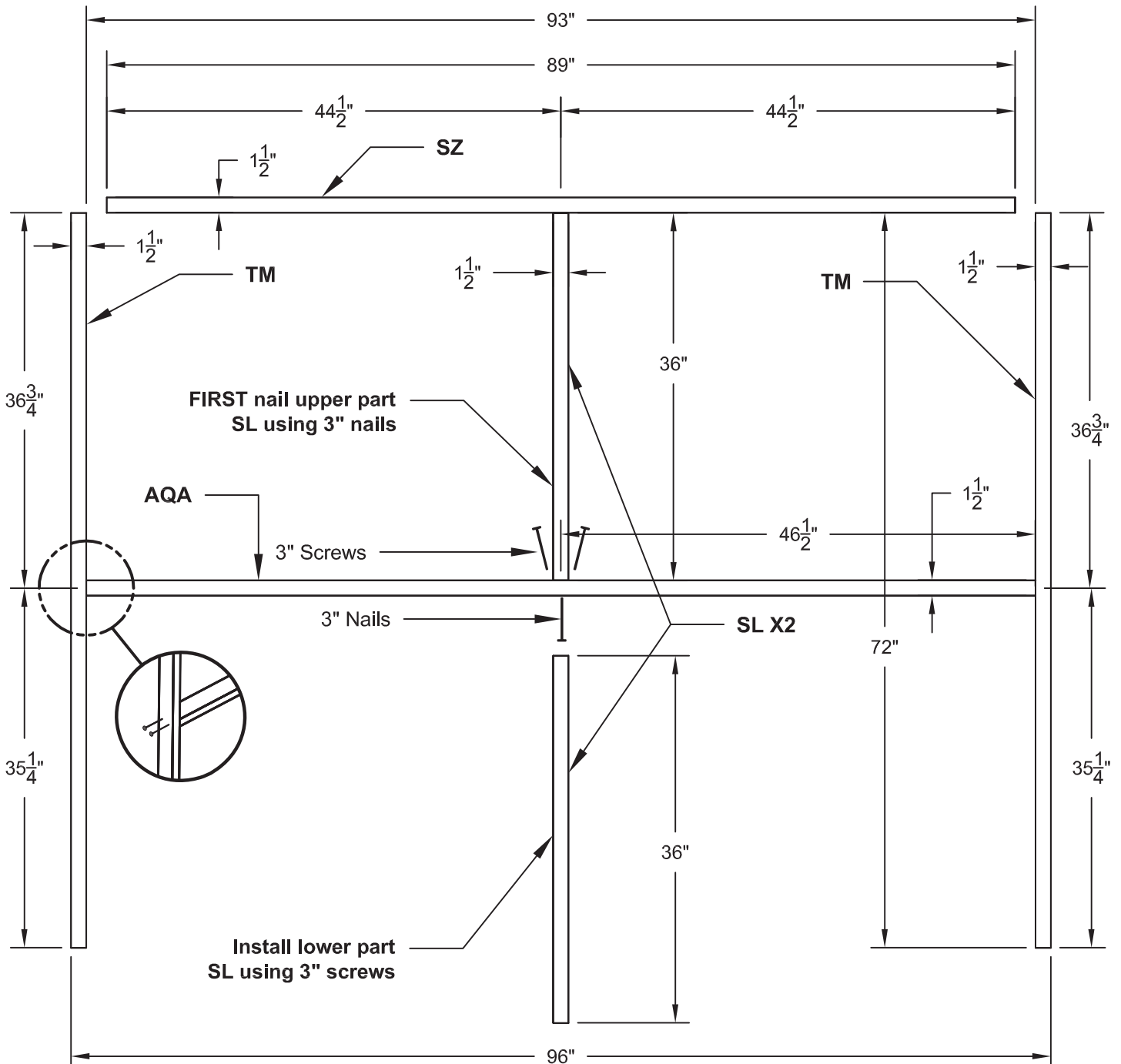

SIDE WALL

Parts Required:

X2 $\frac{3}{8}$ x 48 x 76" Wall Panel



Fasteners Required:

X72 2" Nails

ASSEMBLY STEPS / NOTES:

1. Place panel on frame as shown with primed side facing up.
2. Use a $\frac{3}{4}$ " gauge block at edge of panel. Panel is 1" down from center board and $2\frac{1}{2}$ " down from side board.
3. Nail using 2" nails 6" apart on edges and 12" apart inside panel.

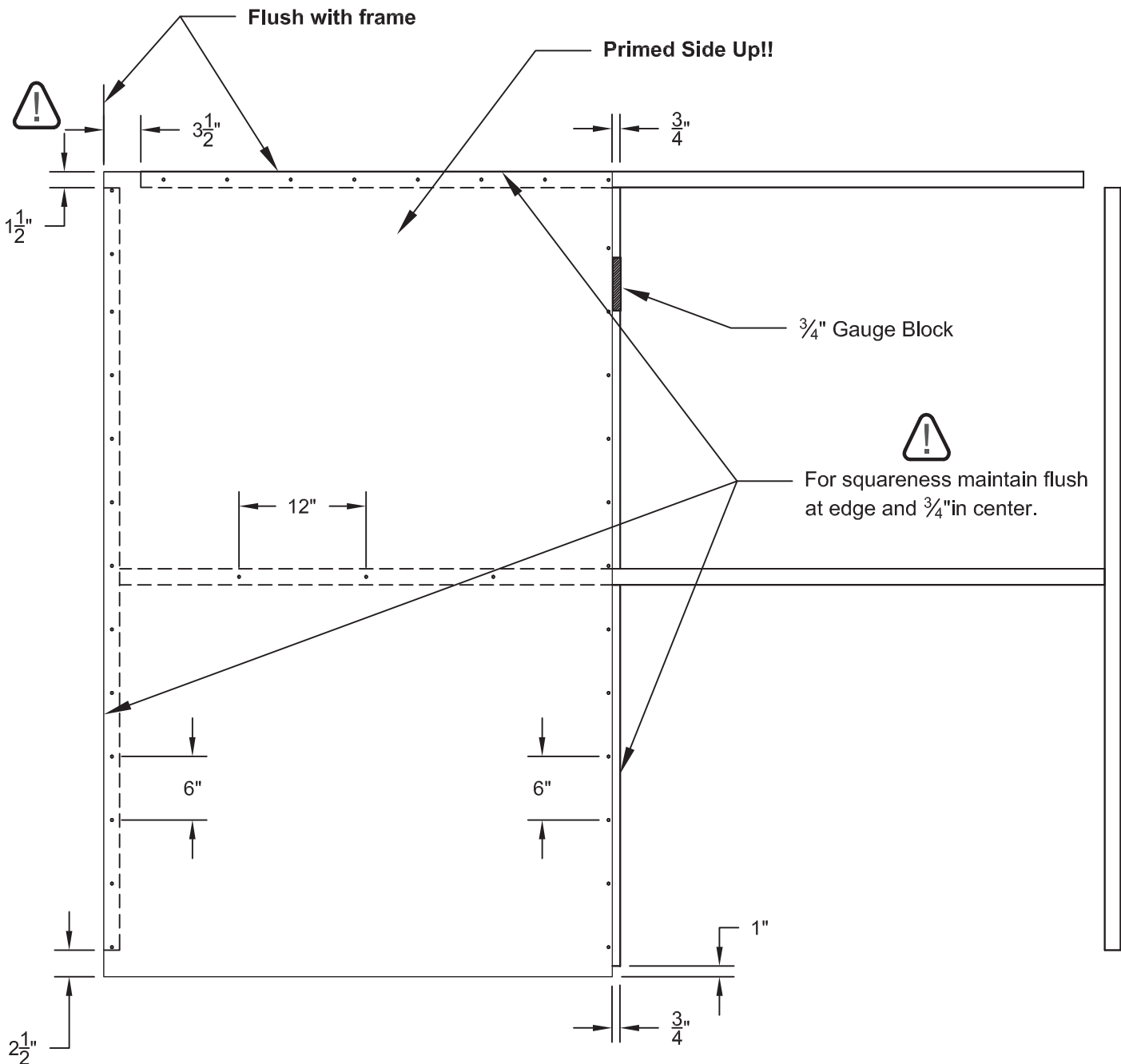

SIDE WALL

Parts Required:

X2 $\frac{3}{8}$ x 48 x 76" Wall Panel



Fasteners Required:

X72 2" Nails

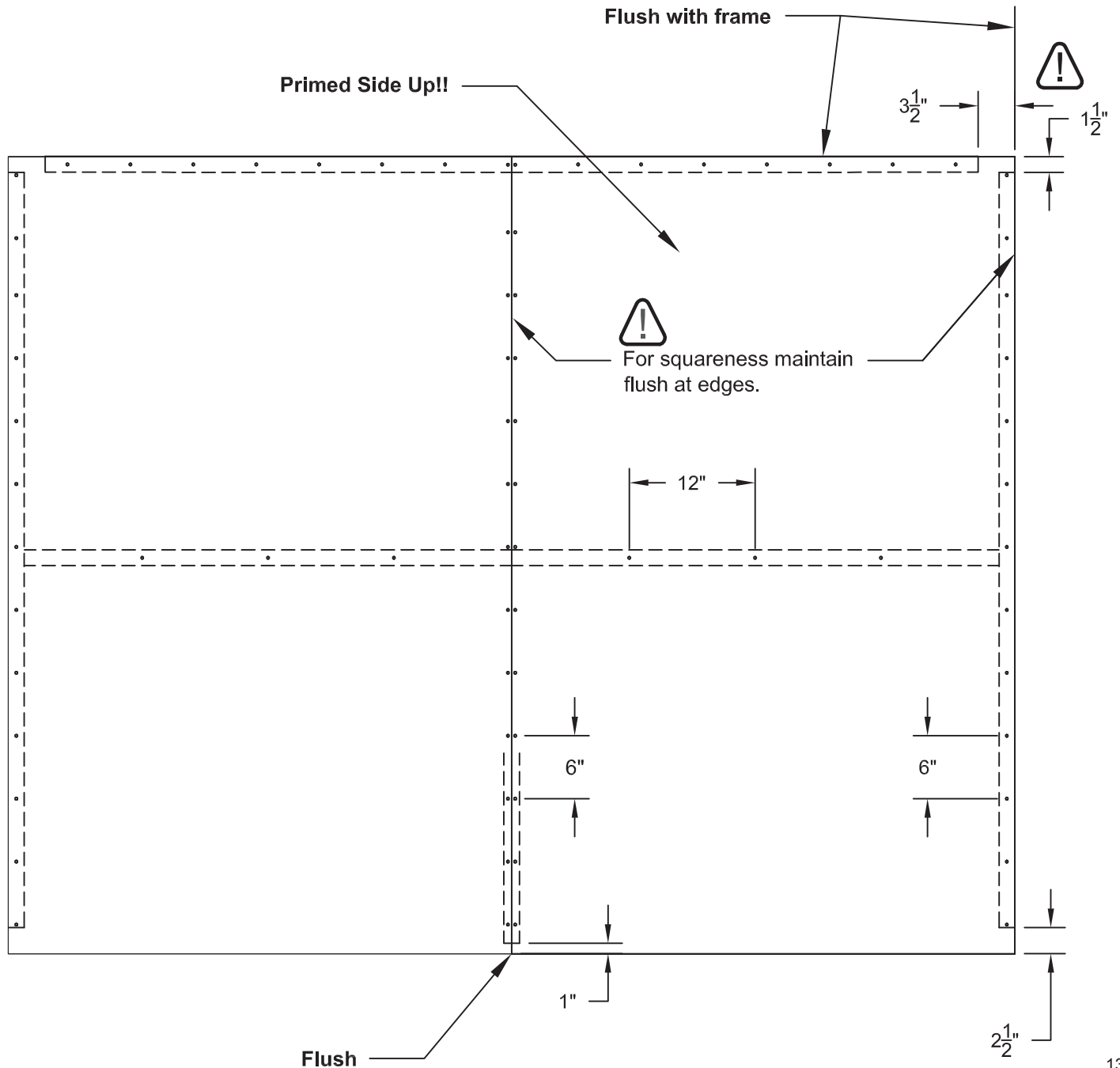

ASSEMBLY STEPS / NOTES:

1. Place panel on frame as shown with primed side facing up.
2. Keep panel flush to other panel and to side frame. Panel is 1" down from center board and 2-1/2" down from side frame.
3. You have finished your Side Wall. Carefully flip the wall over. 
4. Repeat Side Wall steps to build a second Side Wall.



BACK WALL

Parts Required:

X2	2 x 4 x 96"	TP	
X4	2 x 4 x 72"	TM	
X2	2 x 4 x 24"	RL	

Fasteners Required:

X20 3" Nails

ASSEMBLY STEPS / NOTES:

1. Orient parts on edge on floor as shown. Measure and mark.
2. Attach with 3" nails, two at each connection. Angle nails at seams.

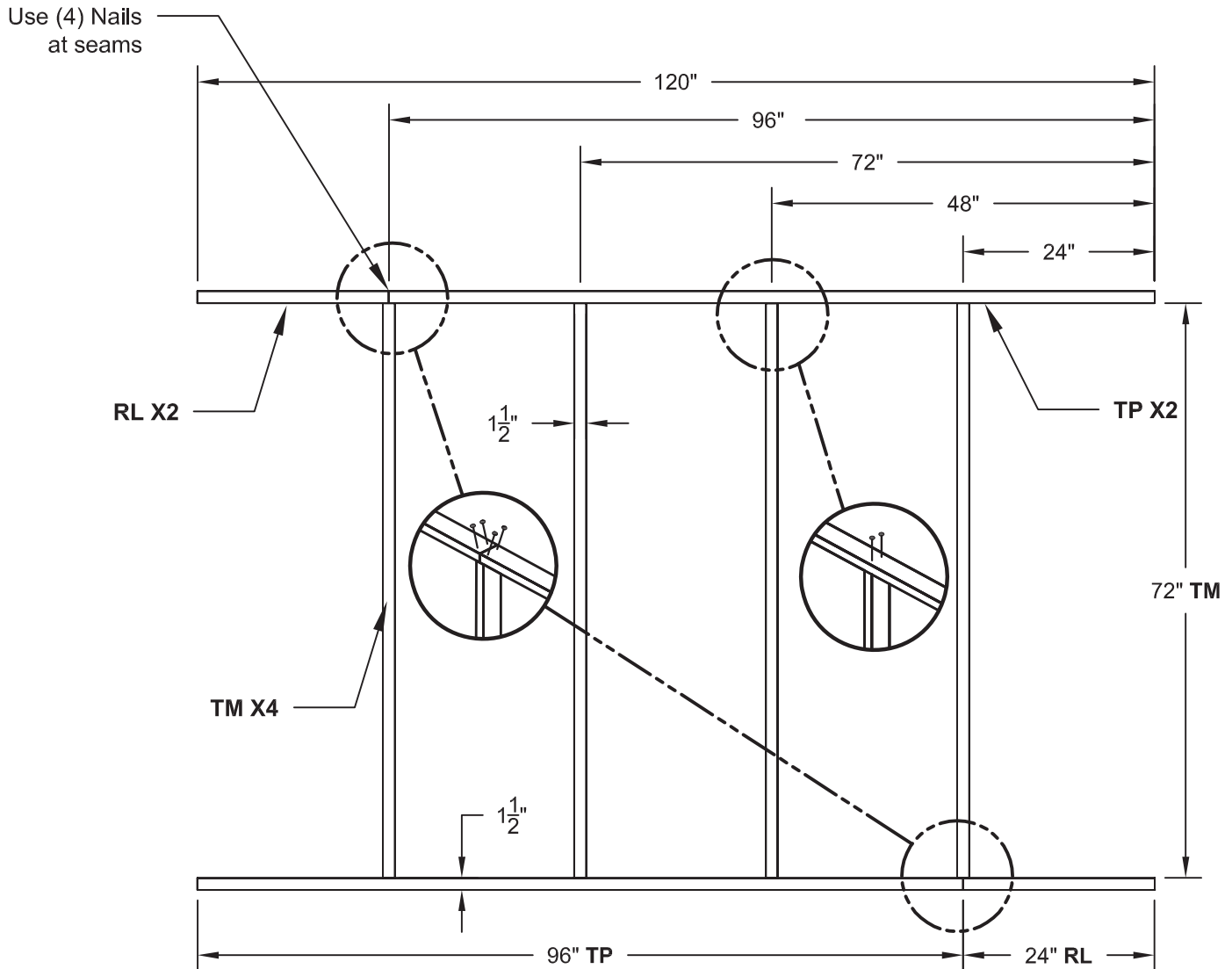

BACK WALL

Parts Required:

X1 $\frac{3}{8}$ x 48 x 76" Wall panel



Fasteners Required:

X36 2" Nails

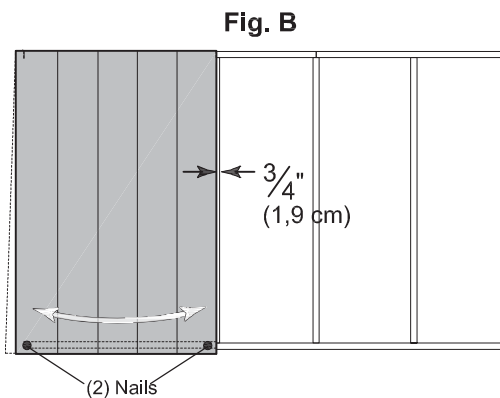
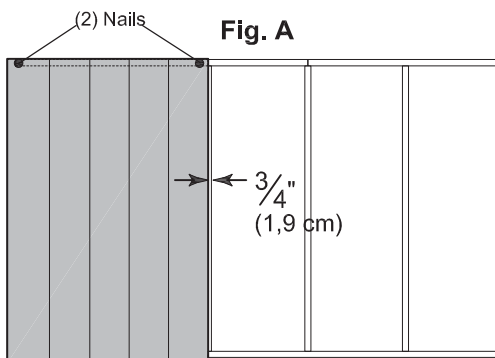
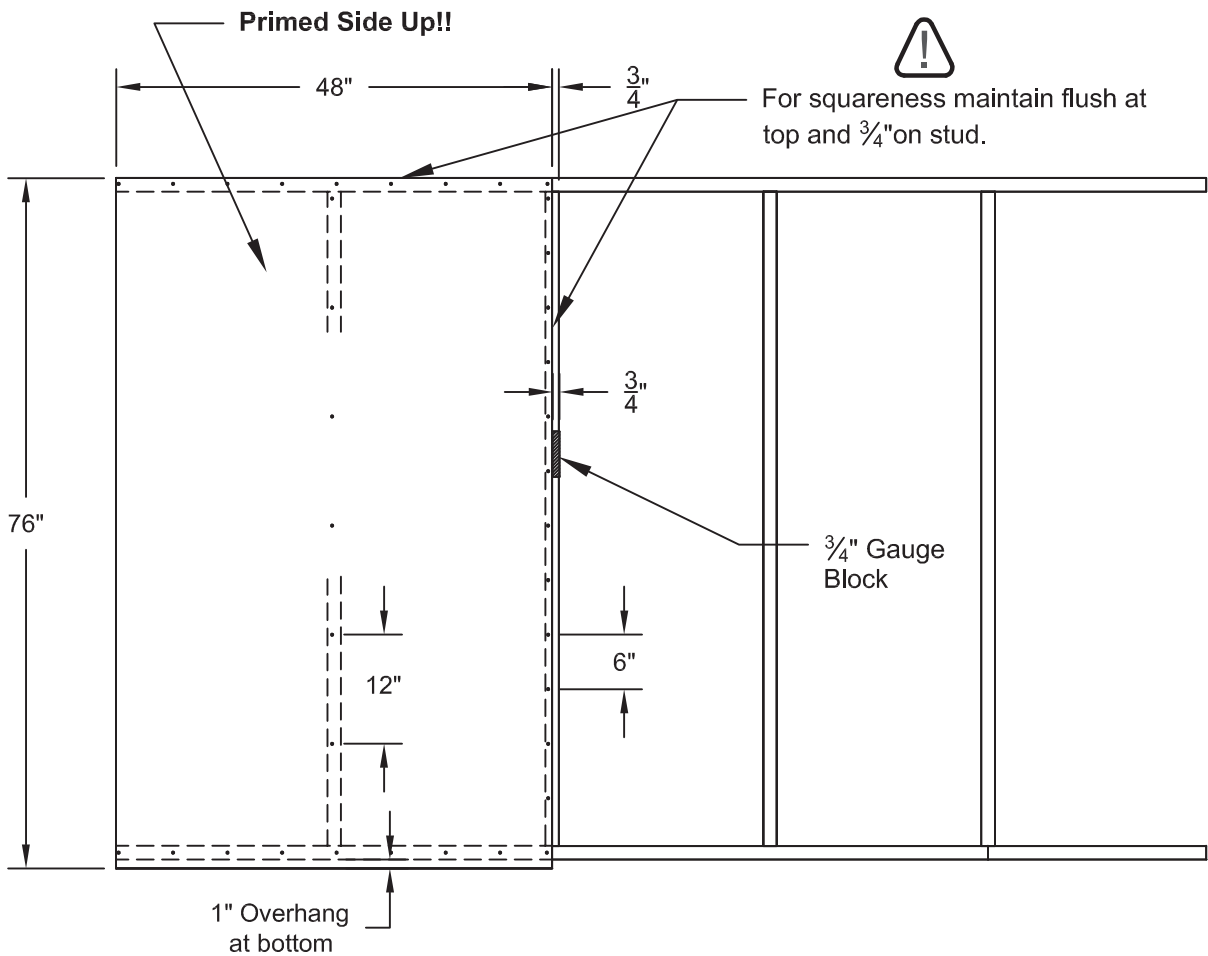

ASSEMBLY STEPS / NOTES:

1. Place the 48 x 76" panel onto the wall frame with primed side up as shown. Use the gauge block to mark the $\frac{3}{4}$ " measurement on the wall stud. Keep panel flush at top. Secure panel with two 2" nails in the corners (Fig. A).
2. Move to the opposite end. Using the long edge of the panel as a lever move the panel side-to-side until you have a $\frac{3}{4}$ " measurement on the wall stud. Secure corner with two 2" nails (Fig. B).
3. Nail the panel using 2" nails 6" apart on edges and 12" apart inside panel.



BACK WALL

Parts Required:

- X1 $\frac{3}{8}$ x 48 x 76" Wall panel 
- X1 $\frac{3}{8}$ x 23-7/8 x 76" Wall panel 

Fasteners Required:

X70 2" Nails

ASSEMBLY STEPS / NOTES:

1. Place the center 23-7/8 x 76" panel on frame as shown with primed side facing up. Nail the panel using 2" nails 6" apart on edges and 12" apart inside panel. Keep flush to the first panel and the top of the frame.
2. Repeat this for the last panel.
3. Carefully flip the wall over.

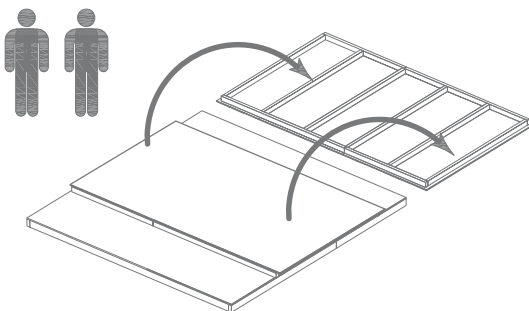
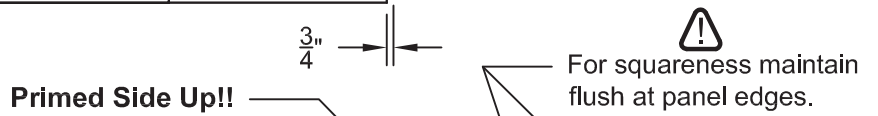
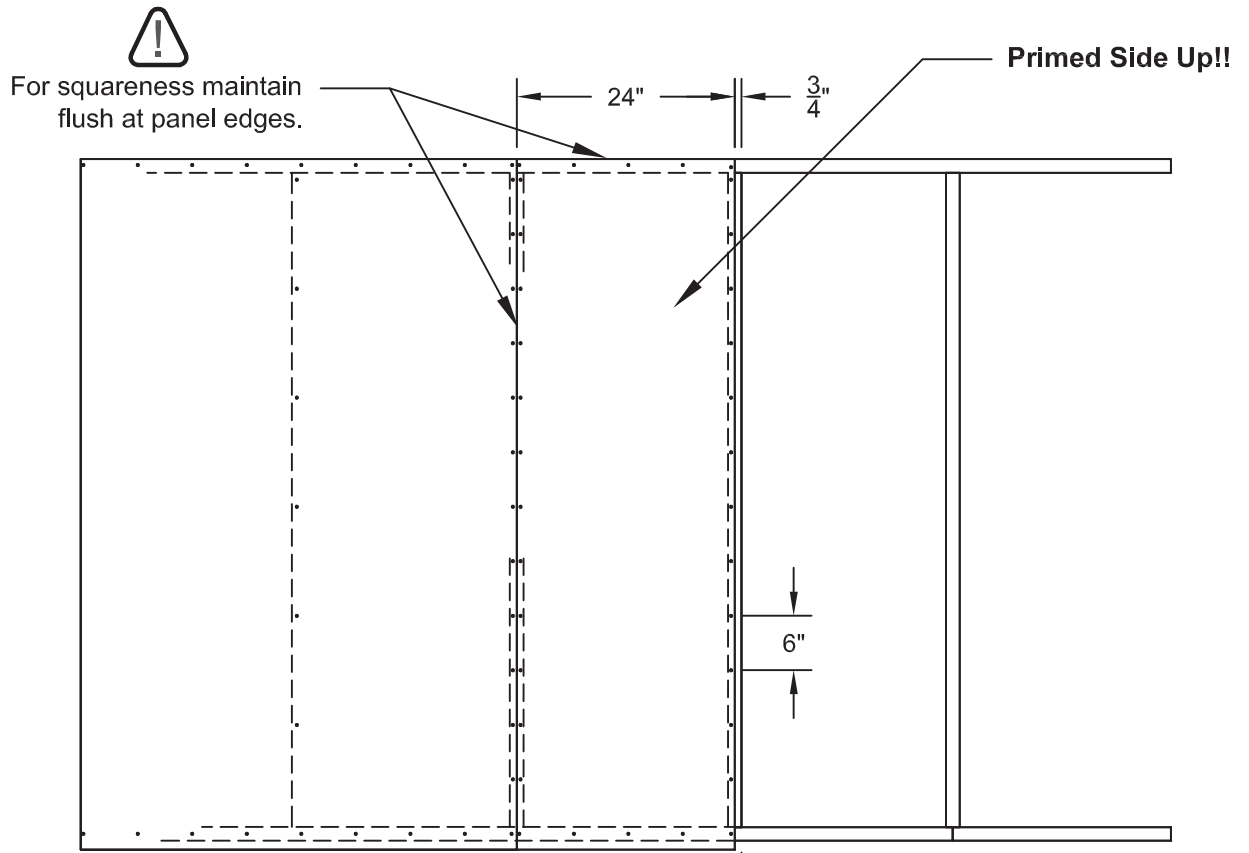

FRONT WALL

Parts Required:

X2 2 x 4 x 51" **TCA**
x1 $\frac{7}{16}$ X 2-1/2 X 48" OSB Spacer

Fasteners Required:

X9 3" Nails

ASSEMBLY STEPS / NOTES:

1. Orient parts on flat on floor as shown. Center the OSB filler on the 51" part **TCA**.
2. Assemble both halves and the filler using 3" (7,6 cm) nails from both sides.

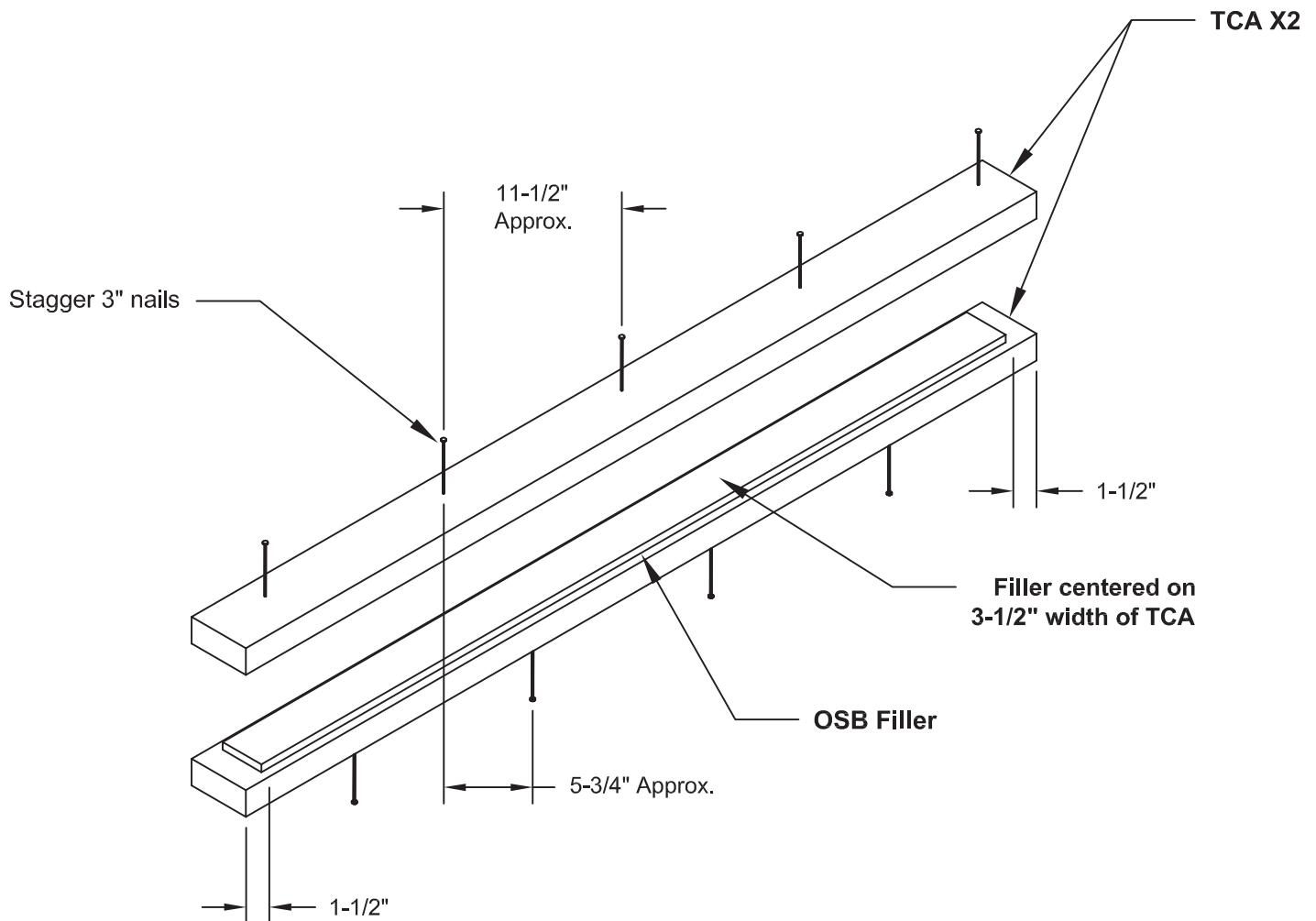

FRONT WALL

Parts Required:

X1	2 x 4 x 96"	TP	X1	2 x 4 x 24"	RL
X5	2 x 4 x 72"	TM	X1	2 x 4 x 16"	RB
X2	2 x 4 x 68-1/2"	YFA			
X1	2 x 4 x 56"	QU			

Fasteners Required:

X53 3" Nails

ASSEMBLY STEPS / NOTES:

1. Orient parts on edge on floor as shown. Measure and mark.
2. Nail the base plates **RB** and **QU** to the door frame **TM** and **YFA** using 3" nails, two at each connection.
3. Nail **TM** and **YFA** together as shown. Nail in at an angle to ensure the nail does not poke through the door frame.
4. Nail header assembly with four 3" nails at ends (**Fig A**).
5. Nail the top plates **RL** and **TP** to both **TM**'s using two 3" nails at each connection, and ten 3" nails staggered into the header assembly (Fig A).

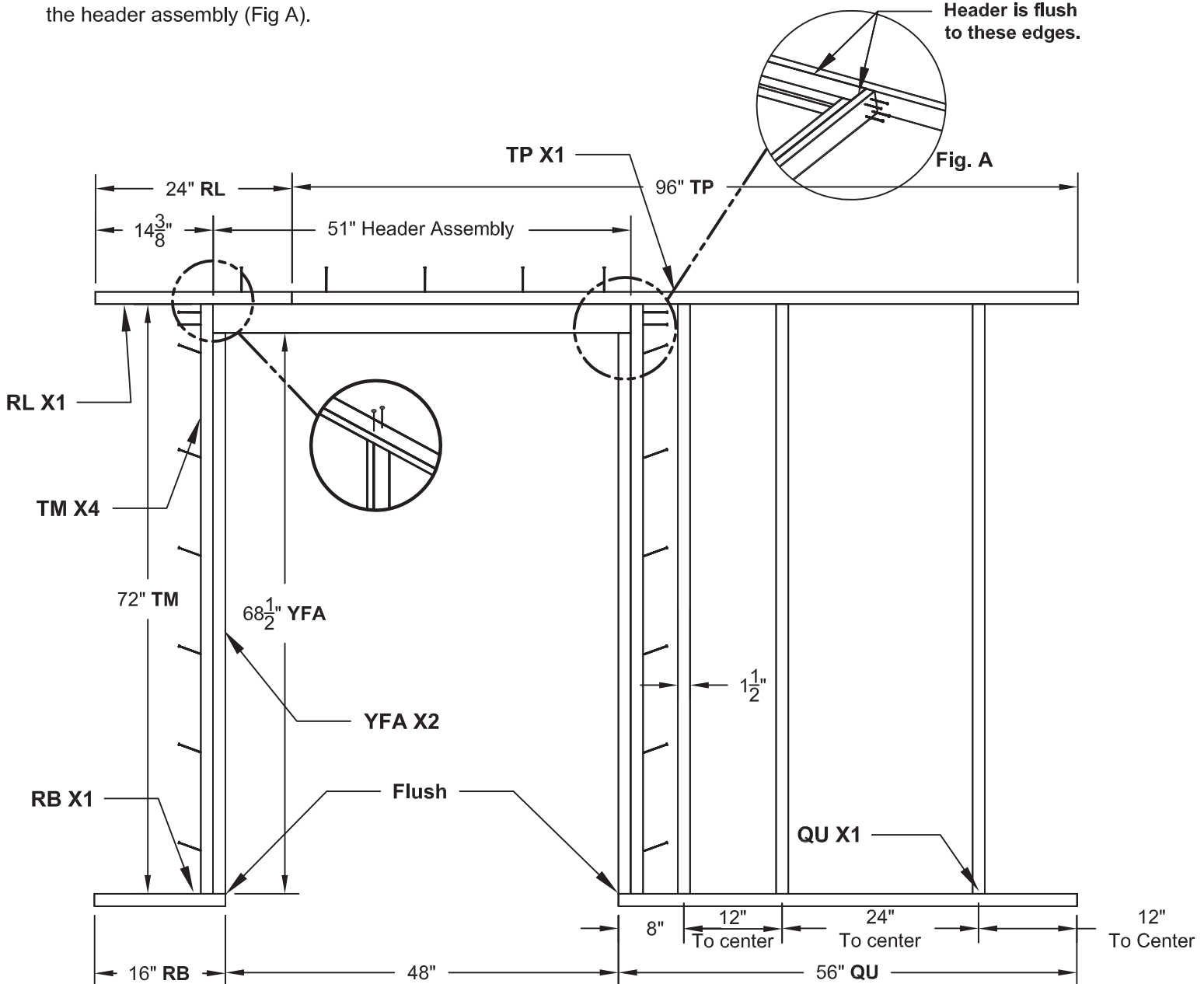

FRONT WALL

Parts Required:

X1 $\frac{3}{8}$ x 15-7/8 x 76"

Wall Panel 

Fasteners Required:

X18 2" Nails

ASSEMBLY STEPS / NOTES:

1. Place the 15-7/8 x 76" panel onto the wall frame with primed side up as shown. Keep panel flush at top and door framing edges with 1" overlap at the bottom.
2. Nail the panel using 2" nails 6" apart on edges.

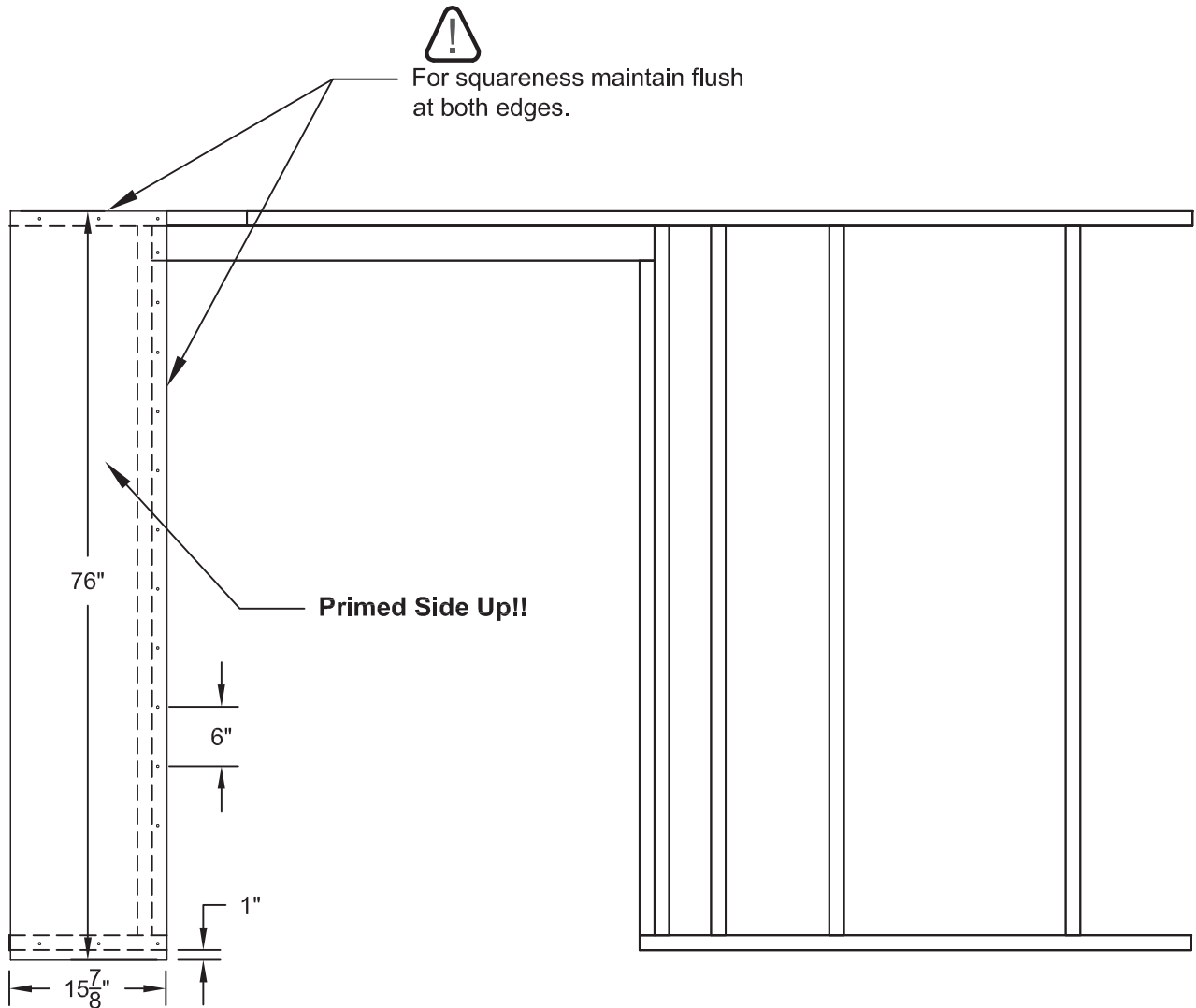

FRONT WALL

Parts Required:

- X1 $\frac{3}{8}$ x 7-7/8 x 76" Wall Panel 
X1 $\frac{3}{8}$ x 4 x 48" Over Door Panel 

Fasteners Required:

X42 2" Nails

ASSEMBLY STEPS / NOTES:

1. Place the 4" x 48" panel onto the wall frame with primed side up as shown. Keep panel flush at top edge.
2. Nail the panel using 2" nails 6" apart on edges.
3. Place the 7-7/8" x 76" panel flush at top and door framing with a 1" overhang at the bottom and nail using 2" nails 6" apart.



For squareness maintain flush at edges.

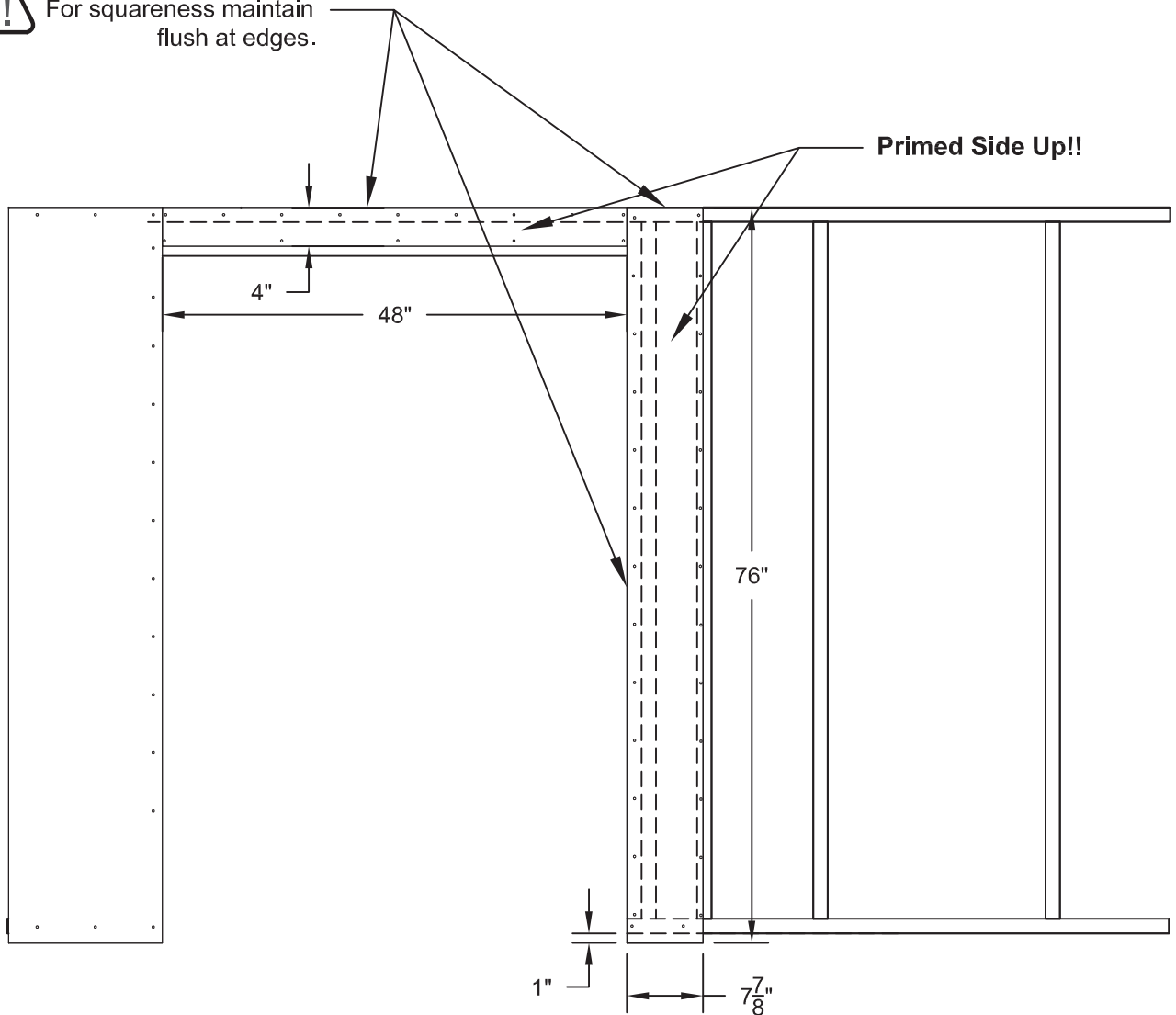

FRONT WALL

Parts Required:

X1 $\frac{3}{8}$ x 48 x 76" Wall Panel



X1 2 x 4 x 69" OO Temporary Brace



Fasteners Required:

X40 2" Nails
X2 3" Screws

ASSEMBLY STEPS / NOTES:

1. Place the 48 x 76" panel onto the wall frame with primed side up as shown. Keep panel flush at top and with other panel edge with a 1" overhang at the bottom.
2. Nail the panel using 2" nails 6" apart on edges and 12" apart inside panel.
3. Attach brace OO with one 3" screw at each end to hold the 48" door opening.
4. Follow instructions in the window kit to cut out window opening.
5. You have finished your front wall. Carefully flip the wall over.

Primed Side Up!!



For squareness maintain flush at both edges.

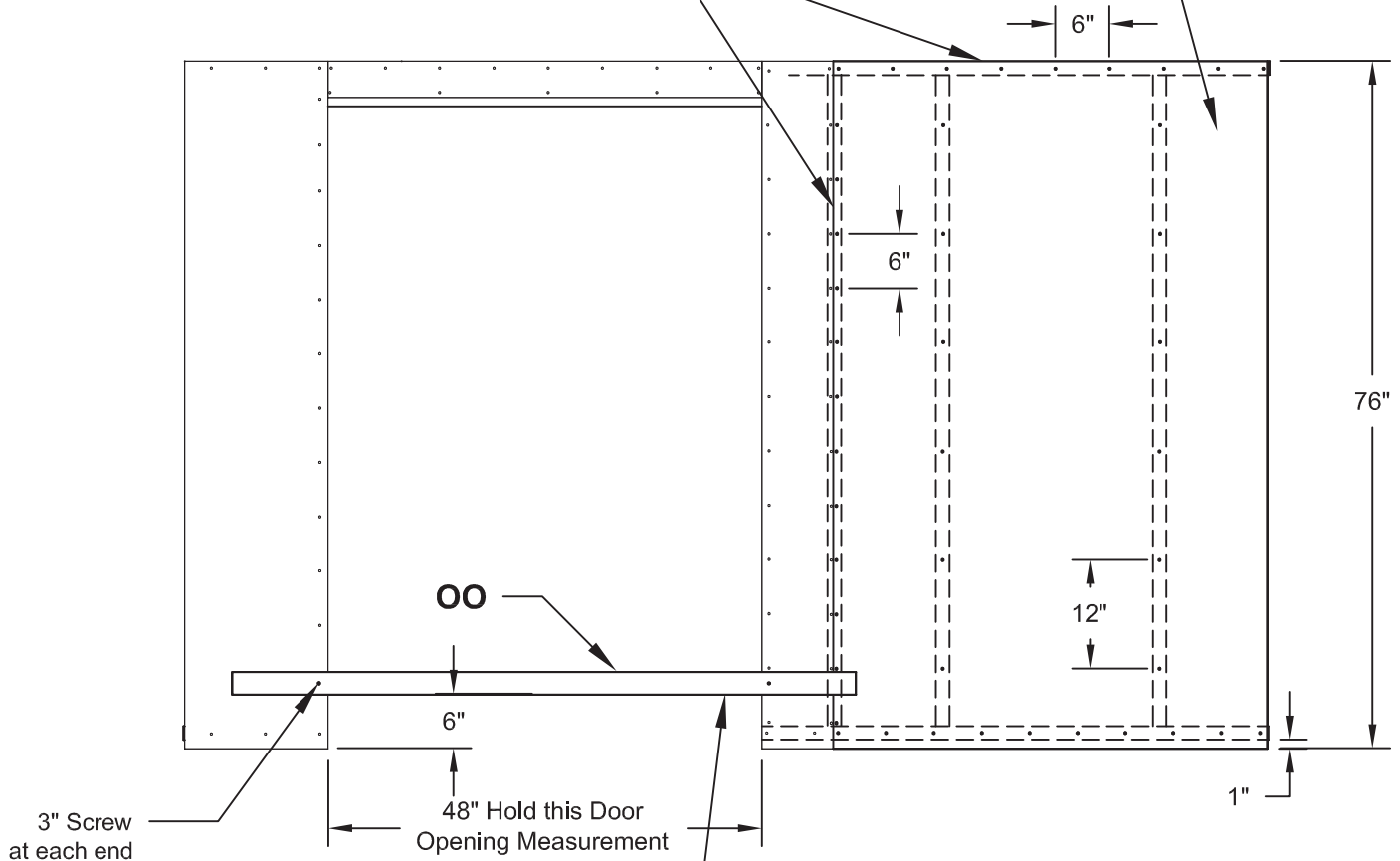

Hold 48" door opening by attaching brace OO using two 3" screws.

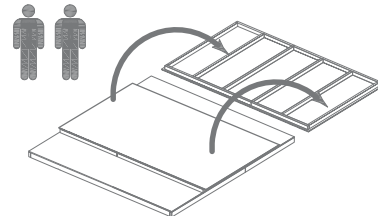

STANDING WALLS



WHILE INSTALLING THE WALLS IT IS IMPORTANT TO BE AWARE OF THE FOLLOWING FRAMING CONDITIONS AND DIMENSIONS ...

ALL WALLS ARE ...

- LEVEL
- PLUMB
- SQUARE

THE FINAL DIMENSIONS WILL BE EQUAL

- FRONT TO BACK
- SIDE TO SIDE
- CORNER TO CORNER

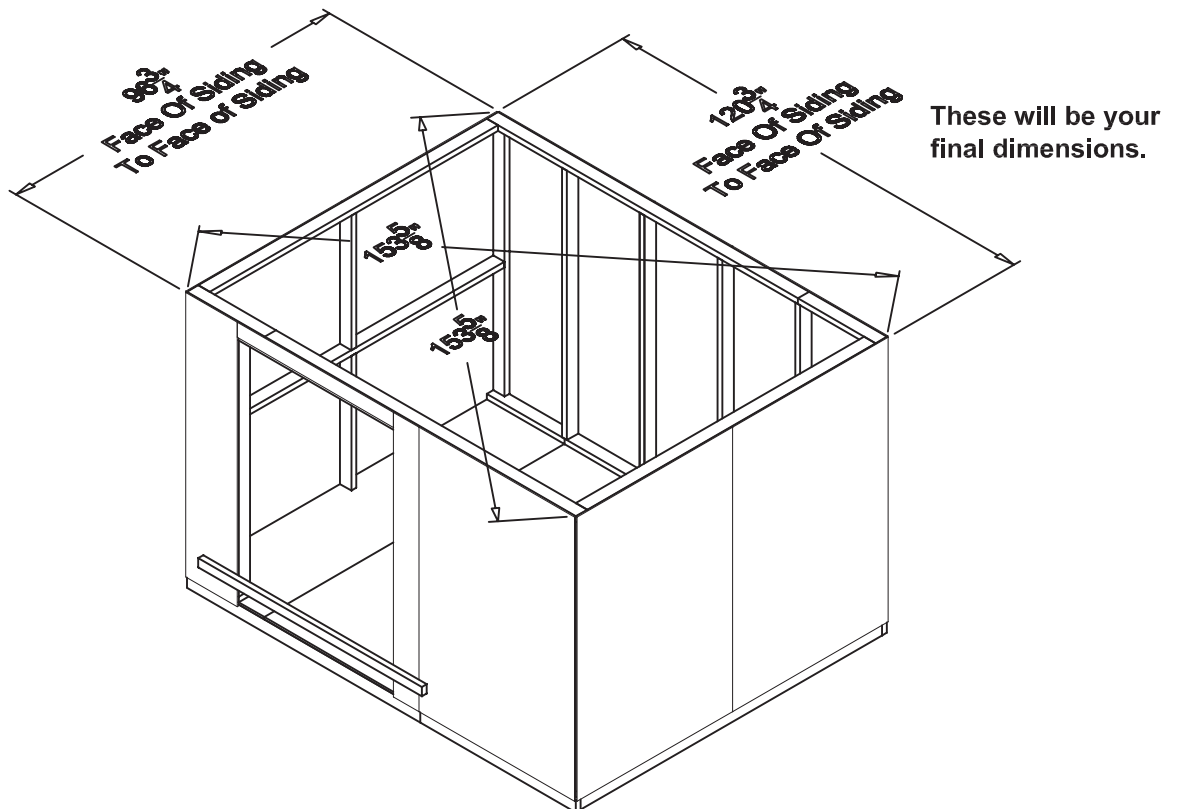

STANDING WALLS

Parts Required:

- X2 Back Wall Assembly
- X1 2 x 3 x 69" Temporary Brace OO

Fasteners Required:

- X2 3" Screw
- X21 2" Nails
- X10 3" Nails

ASSEMBLY STEPS / NOTES:

1. Stand back wall on floor. Overhang is to bottom of panel. Center back wall on the 120" floor dimension. 
2. Use **OO** as a temporary brace. Secure with two 3" screws.
3. First, nail along lower edge of panel to floor frame using 2" nails 6" apart. Angle nail to hit floor frame (Fig. A, B).
4. Second, nail through the bottom plate using two 3" nails between studs. Angle nails to hit floor frame. (Fig. A.)

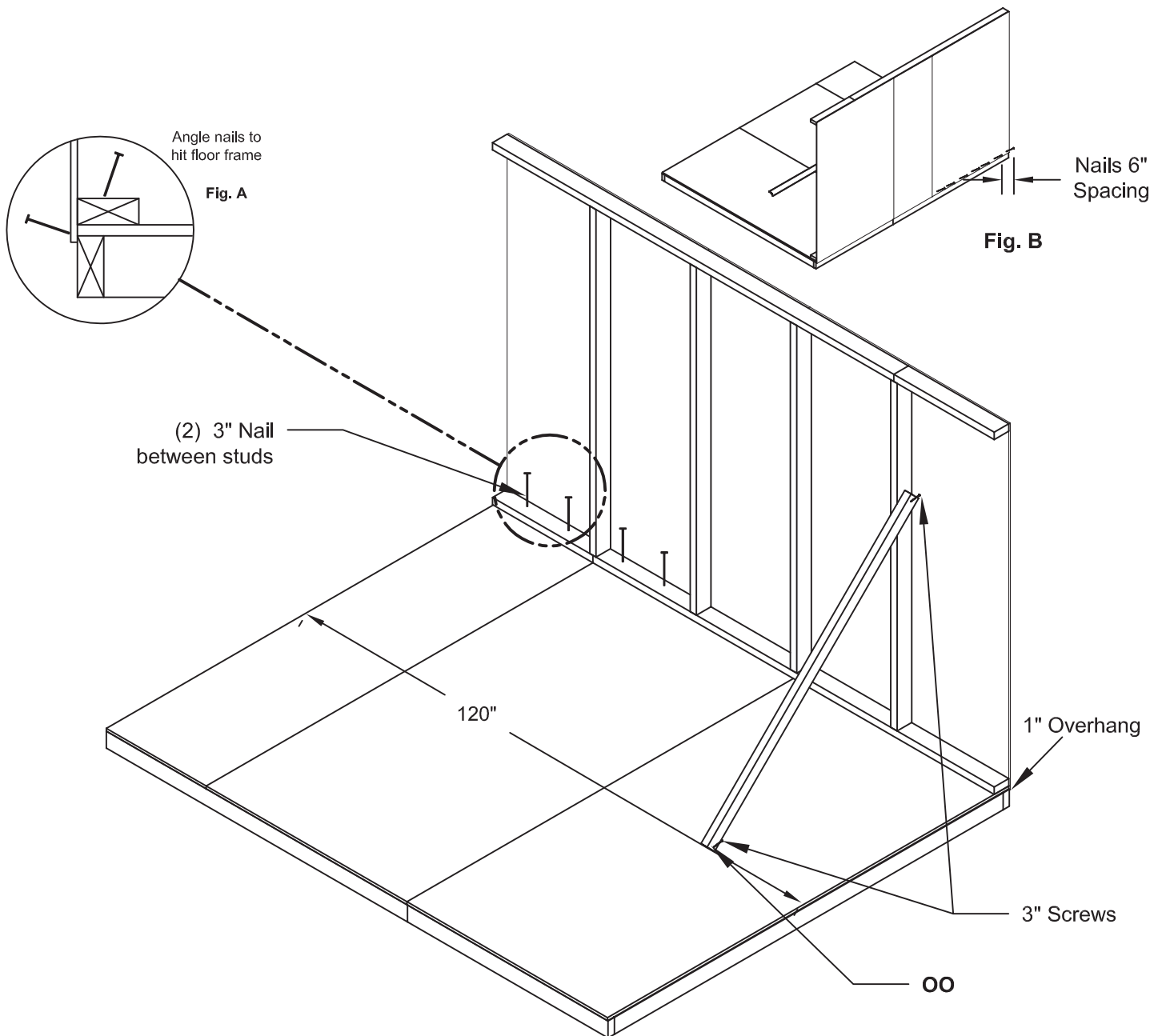

STANDING WALLS

Parts Required:

X2	Side Wall Assemblies	
X1	2 X 4 X 13-7/8"	URA

Fasteners Required:

X28	1-1/2" Nails
X36	2" Nails
x8	3" Screws

ASSEMBLY STEPS / NOTES:

It is important to secure the walls in the following order.

- Center side wall side-to-side on the 96" floor dimension.

In the corner make sure the side wall frame rests on the back wall bottom plate.

Nail the lower corners to the floor frame with one 2" nail each. Angle the nails to hit the floor frame (Fig. A)

Note: There should be a 1-1/2" gap at the opposite side. Use **URA** as a temporary support for the 1-1/2" gap before nailing the corners.

1 1/2"
Gap

URA

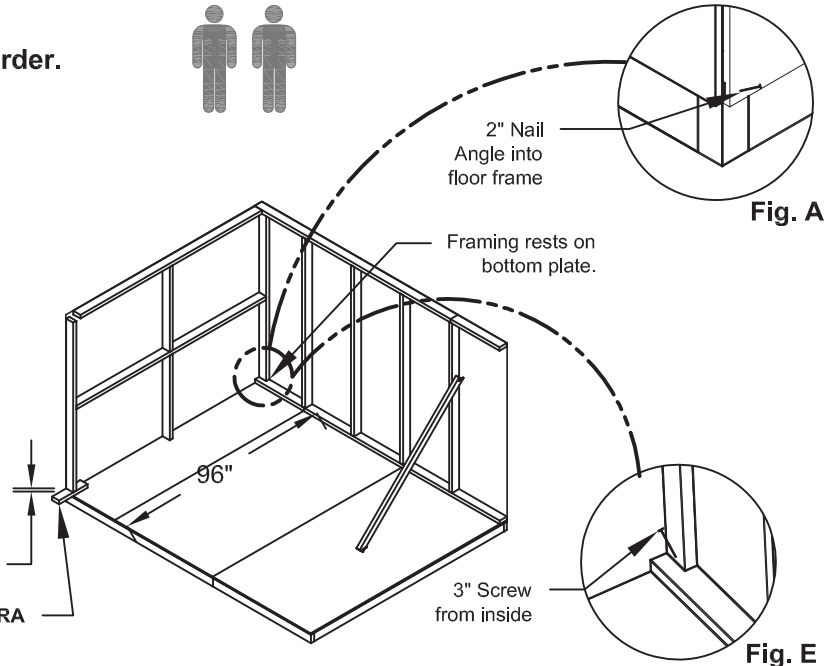

Fig. A

Fig. E

- Be sure the measurement between the panel edges is consistent along the entire length. Then secure with one 2" nail in the upper corner (Fig. B).

Nail along the back panel edge into the frame using 1-1/2" nails spaced 6" apart.

Nail along bottom of panel using 2" nails 6" apart. Angle nail to hit floor frame (Fig. C).

- From inside secure the side wall frame using 3" screws through the frame into the floor (Fig. C) and through the frame into the upper side wall plate (Fig D) and lower side wall plate (Fig E).

Remove the temporary brace.

Move to the opposite side and repeat steps to stand the opposite sidewall.

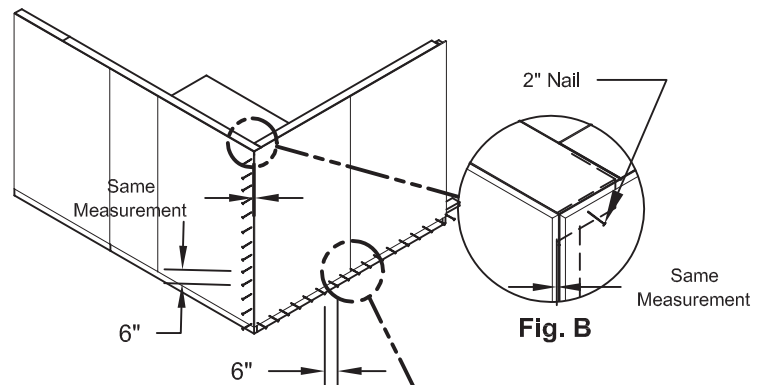

Fig. B

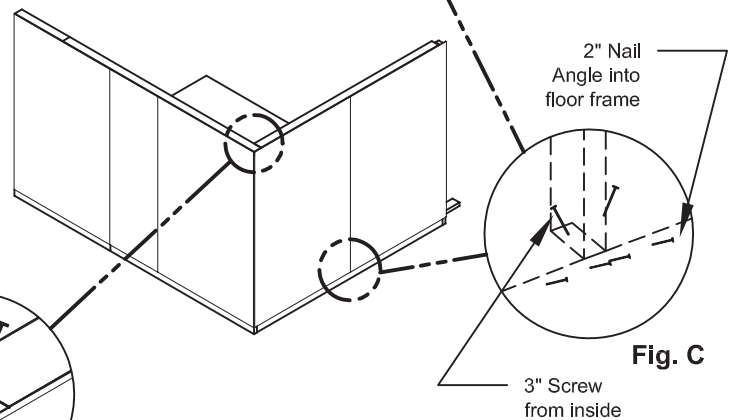
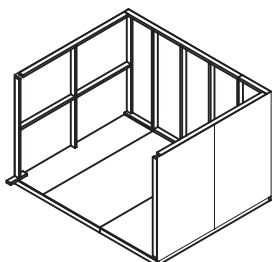

Fig. C



3" Screw
from inside

Fig. D

3" Screw
from inside

STANDING WALLS

Parts Required:

X1 Front Wall Assembly

Fasteners Required:

X28 1-1/2" Nails

X17 2" Nails

x8 3" Nails

x4 3" Screws

ASSEMBLY STEPS / NOTES:

It is important to secure the front wall in the following order.



Begin by standing the front wall on the floor.

- Center front wall on floor side-to-side. Make sure the bottom plate is securely in the 1-1/2" gaps at both side walls

Check the 48" door opening is held before nailing.

Nail the front wall flush to the floor using 2" nails 6" apart. Angle nails to hit floor frame (Fig. A).

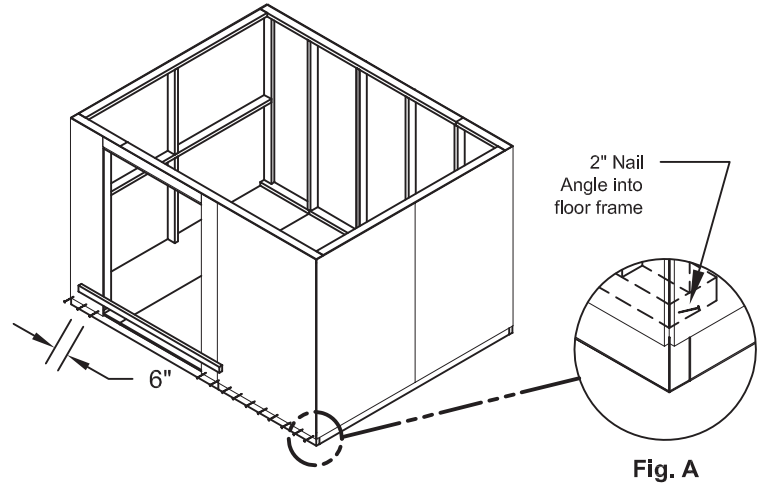

- Be sure the measurement between the panel edges is consistent along the entire length. Then secure with one 2" nail in the upper corner (Fig. B) and lower corner (Fig. A).

Nail along the panel edge into the frame using 1-1/2" nails spaced 6" apart.

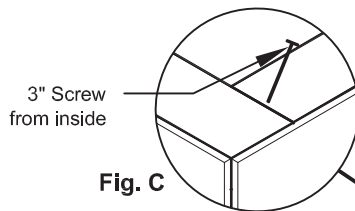
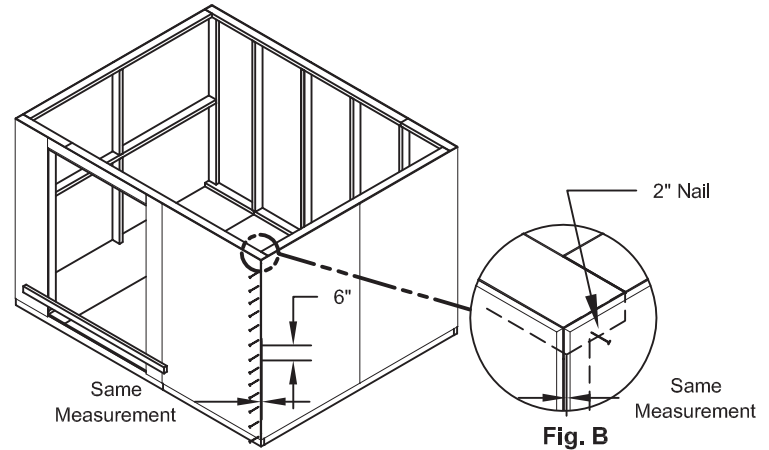

- From inside secure the front wall frame using 3" screws through the frame into the upper side wall rail (Fig C).

- Nail through the bottom plate using two 3" nails between studs. Angle nails to hit floor frame. (Fig. D.)

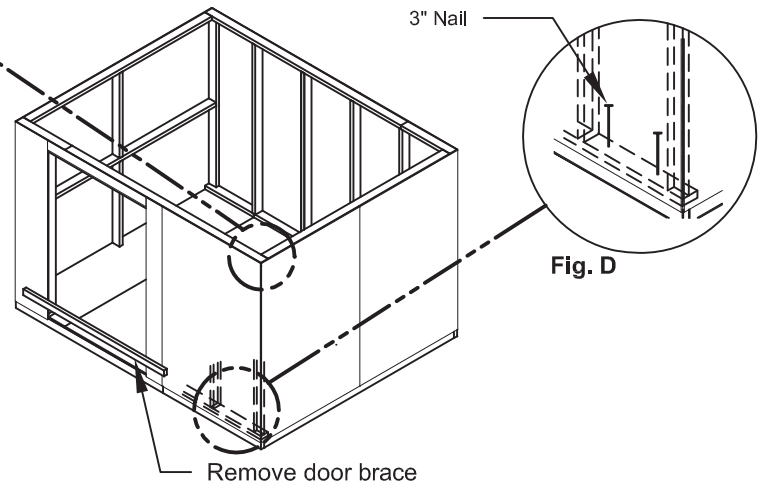

Move to the opposite side and repeat process.

Remove the temporary braces.

You have finished standing your walls.

TRUSSES

Parts Required:

X12 Trusses

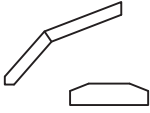

X10 Gussets



Fasteners Required:

X120 2" Nails

x2 3" Screws

ASSEMBLY STEPS / NOTES:

1. You will assemble (6) trusses. **(2) Trusses have only ONE gusset. (4) Trusses have TWO gussets**. Make a jig so trusses all have the same measurement using the shed floor and $\frac{3}{4}$ " gauge block.
2. Measure $96\frac{3}{4}$ " from the corner and screw down the $\frac{3}{4}$ " gauge block securely.
3. Place truss parts in jig as shown. Apply glue to trusses where the gusset will fit. Ends of trusses must touch at the peak. Nail gusset to trusses with a $\frac{1}{4}$ " offset using twelve 2" nails in pattern shown. (Fig. A)
4. On **TWO** trusses install **ONE** gusset. On **FOUR** trusses flip over rafter assembly and attach a **SECOND** gusset.

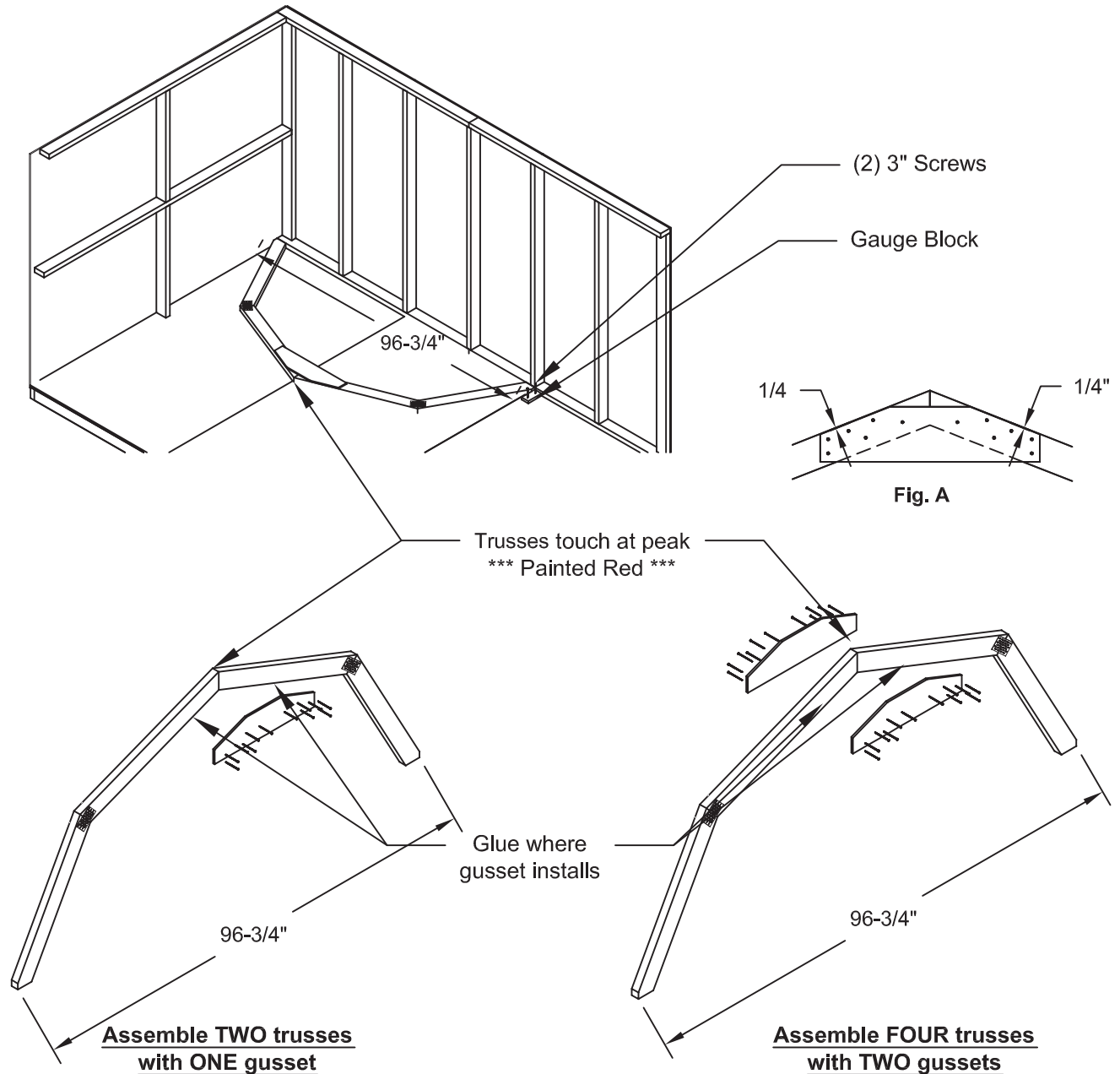

TRUSSES

Parts Required:

- X4 Truss Assemblies w/2-Gussets
- X2 Truss Assembly w/1-Gusset

Fasteners Required:

- X20 3" Screws

ASSEMBLY STEPS / NOTES:

1. Mark top of wall frames to measurement shown.
2. Locate end trusses flush against outside of wall panel. Secure end truss to wall panel using one 3" screw angled through truss into top plate. (Fig. A). Move to the opposite end and repeat to secure the other truss end.
3. Center middle trusses on marks. Hold rafter end flush to outside wall panel and secure using 3" screws angled through rafter into top plate. (Fig. A). Move to the opposite end and repeat to secure the other trusses end.
4. Repeat steps to attach all trusses.

 **Check that sidewalls are still straight after truss install. It may be necessary to use a temp brace to realign wall until roofing is installed.**

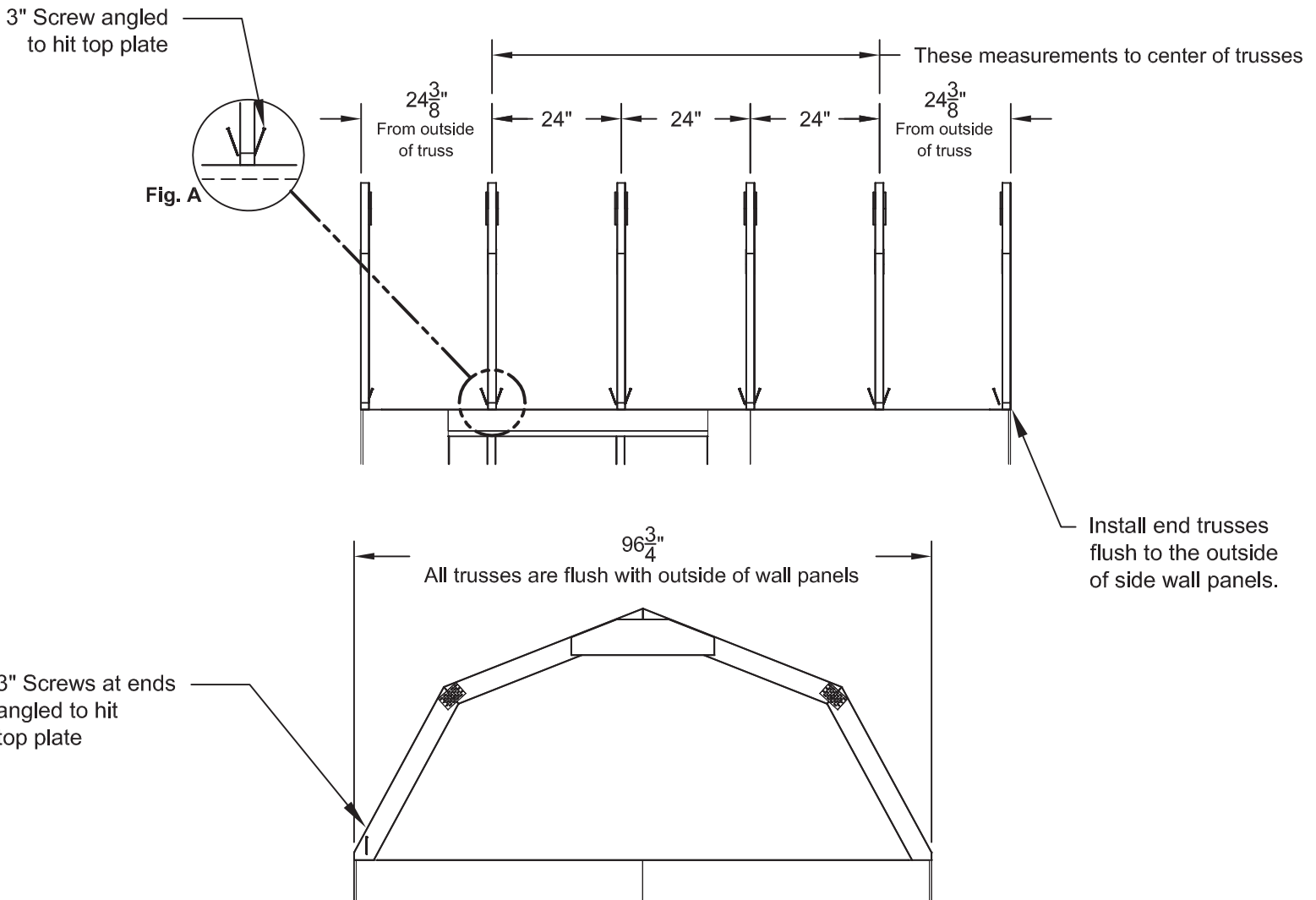
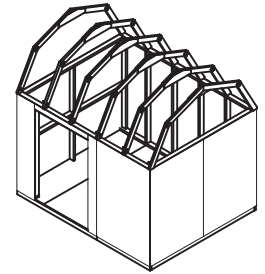

GAMBREL CAPS

Parts Required:

X2 Gable Panel Left
 X2 Gable Panel Right

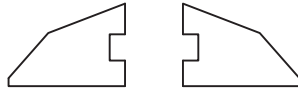

X4 2 x 4 x 13-7/8"



X1 2 x 3 x 69"

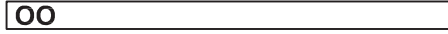

Fasteners Required:

X24 1-1/2" Nails

ASSEMBLY STEPS / NOTES:

- Center Gable Panel as shown across gable connectors **URA** primed side up. Leave 1" overhang on bottom.
- Use **OO** as a temporary support.
- Nail the panel using 1-1/2" nails 6" apart.
- Repeat Steps 1-3 for the other side of the panel. Keep the panels flush at the bottom.
- Repeat Steps 1-4 to assemble another gable.

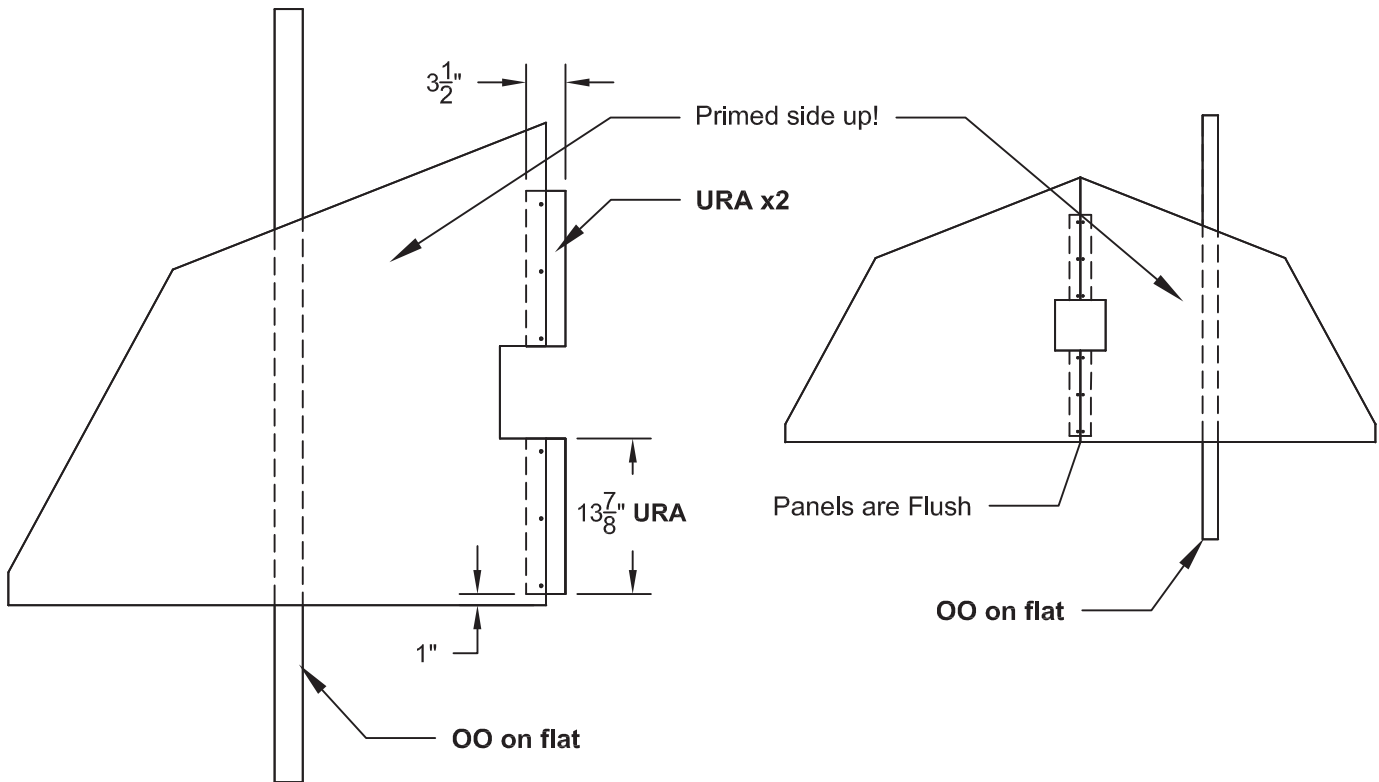

GABLE INSTALL

Parts Required:

X2 Gable Panel Assembly

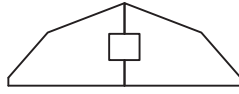

Fasteners Required:

X80 1-1/2" Nails

X4 3" Screws

ASSEMBLY STEPS / NOTES:

1. Lift side gable panel assembly into place. Center the gable on the front of the wall. Keep the gable connectors flush with the top plate.
2. Using 3" screws, angle the screw through the gable connector to hit the top plate (Fig A).
3. Nail the panel around the outside edge using 2" nails 6" apart.
4. Repeat steps for the other side.

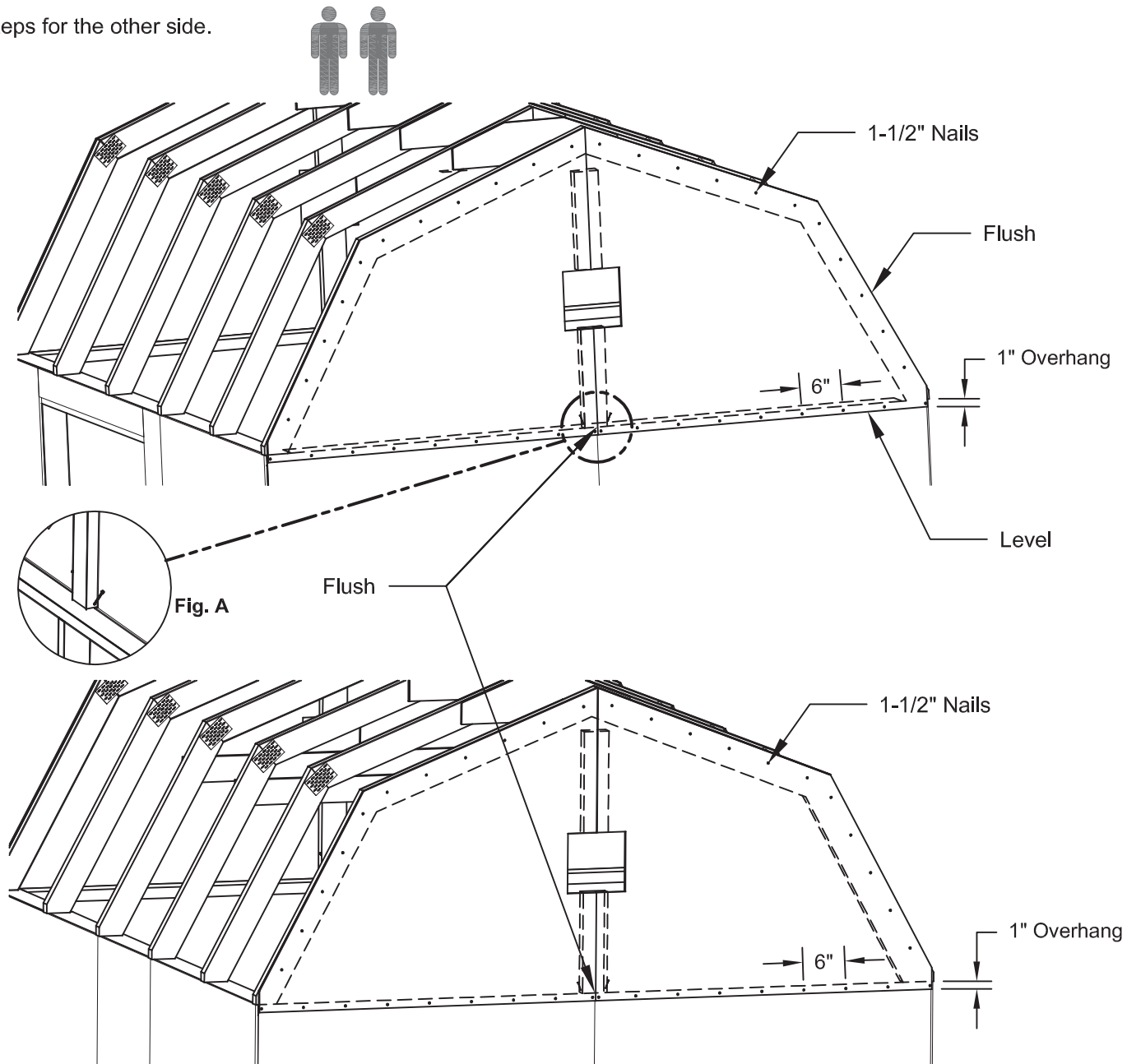

ROOF

Parts Required:

X1 $\frac{7}{16}$ x 35-7/8 x 96"

OSB Panel



Fasteners Required:

X4 2" Nails

ASSEMBLY STEPS / NOTES:

Roof panels may cause serious injury until securely fastened.



1. You must square the roof by attaching one panel first. You will use the panels' long edge as a lever to bring your roof into square. Commonly known as "racking".

2. Attach the $35 \frac{7}{8}$ x 96" panel with the rough side up (painted-grid lines side) with a $\frac{3}{4}$ " measurement on the truss (Fig A) and the panel flush at the peak (Fig. B).

Secure panel with two 2" nails in the corners.

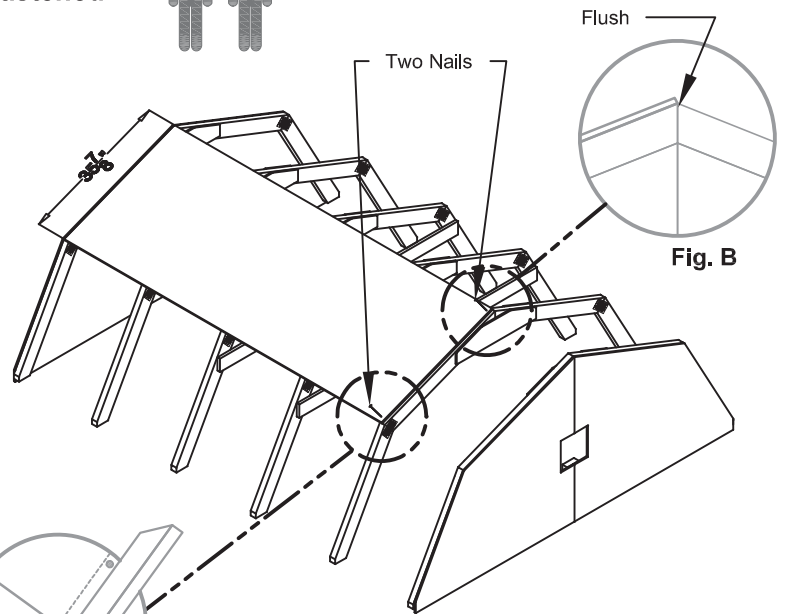

Fig. A

Fig. B

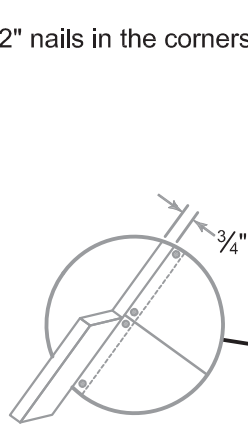

Fig. D

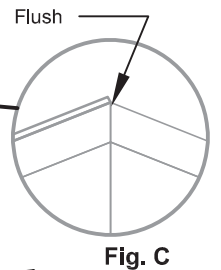
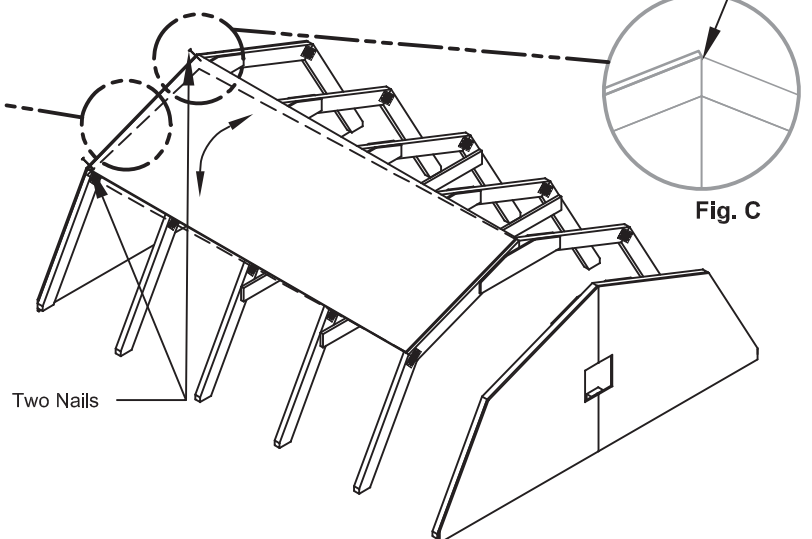

Fig. C

3. Move to the opposite end. Using the long edge of the panel as a lever move the panel side-to-side until the top corner is flush to the peak (Fig. C) and there is $\frac{3}{4}$ " measurement on the truss (Fig. D).





Secure panel with two 2" nails in the corners.

Two Nails



ROOF

Parts Required:

X2	$\frac{7}{16}$ x 35-7/8 x 23-7/8"	OSB Panel	
X2	$\frac{7}{16}$ x 23-7/8 x 96"	OSB Panel	
X2	$\frac{7}{16}$ x 23-7/8 x 23-7/8"	OSB Panel	
X1	$\frac{7}{16}$ x 35-7/8 x 96"	OSB Panel	



Fasteners Required:

X130 2" Nails

ASSEMBLY STEPS / NOTES:

Roof panels may cause serious injury until securely fastened.



- Keep spacing between the center of the trusses at the lower edge of the panel and secure with one 2" nail into each truss (Fig. E).

Move to the top of the panel and keep spacing between the center of the trusses. Secure with one 2" nail into each truss (Fig. E).

Nail the roof panel using 2" nails 6" apart on edges and 12" apart inside panel.

Attach the 35-7/8 x 23-7/8" roof panel flush to first panel along edge and with the peak of the roof along the top. With a 3/4" measurement between the roof panel and the front gable panel (Fig. G & F).

- Attach one lower 23-7/8 x 96" roof panel flush to the installed panel along the peak with a 3/4" measurement on the truss (Fig. H & I).

Nail the roof panels using 2" nails 6" apart on the outside and 12" apart on the inside.

- At one end attach a 23-7/8 x 23-7/8" roof panel flush to the installed lower panel along the edge and the upper panel along the peak (Fig. H).

Nail the roof panel using 2" nails 6" apart on the outside and 12" apart on the inside.

- Repeat these steps for the other side.

Note: The last row of roof panels will be added later.

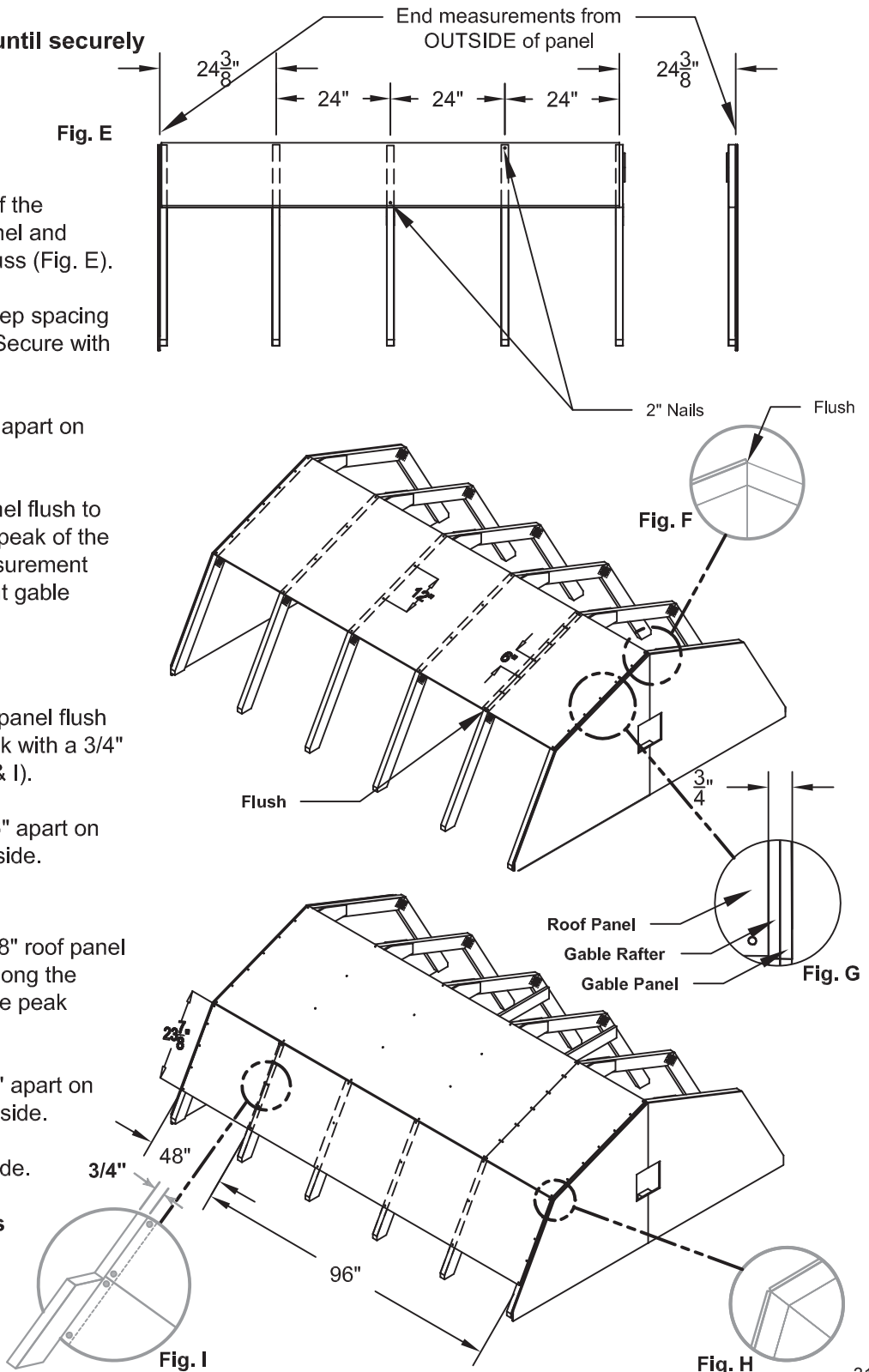

COLLAR TIES

Parts Required:

X2 1 x 4 x 72"

Fasteners Required:

X12 2" Nails

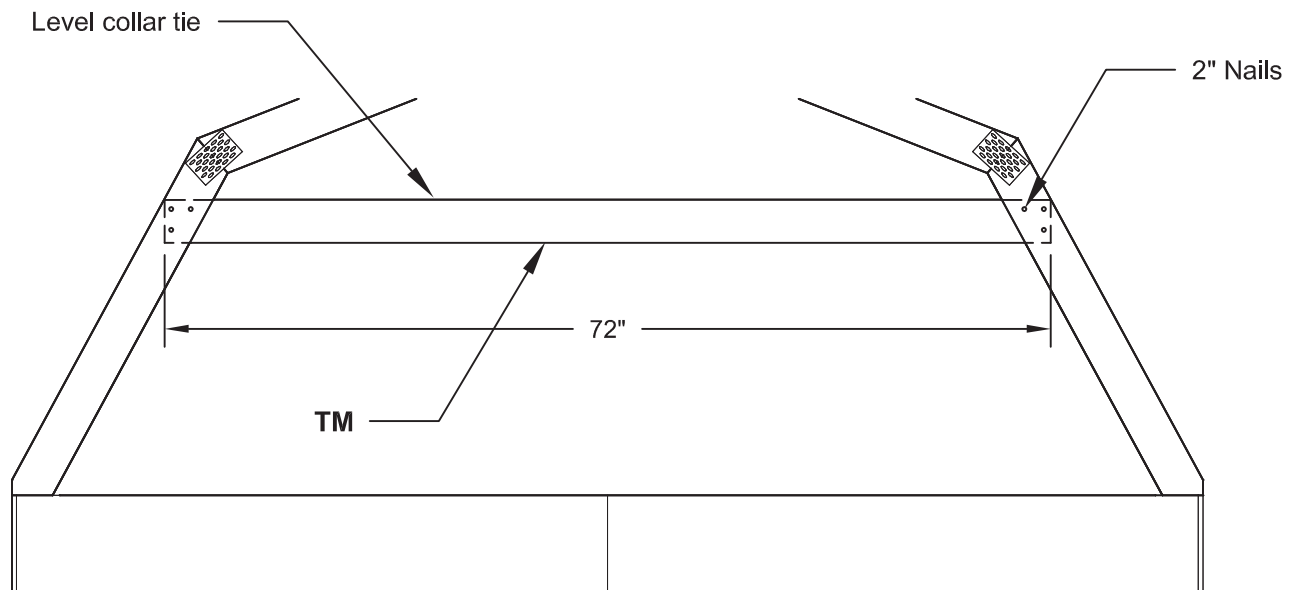
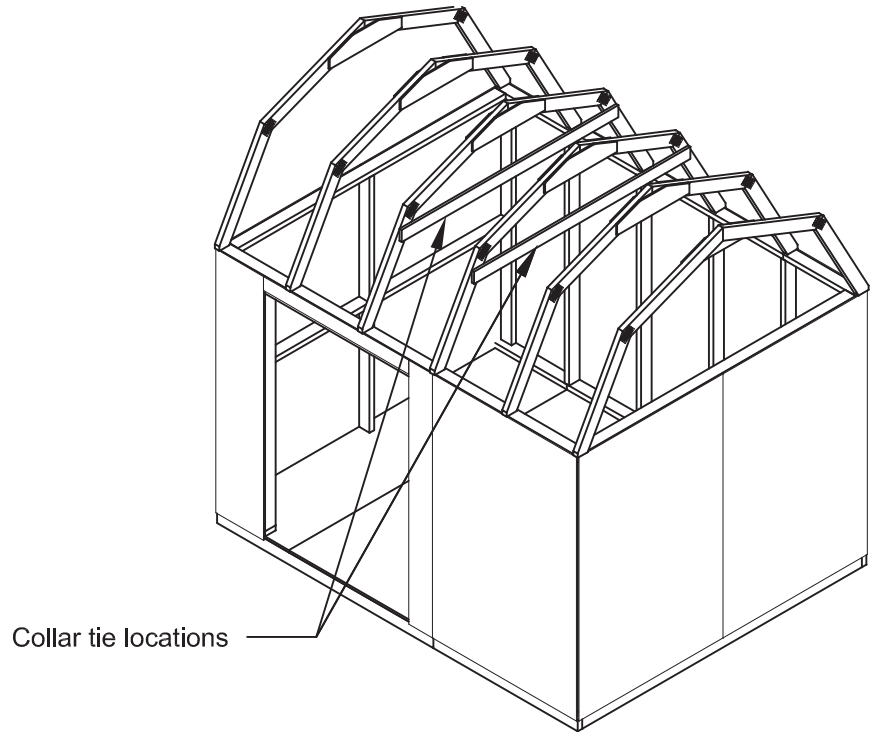

ASSEMBLY STEPS / NOTES:

1. Locate collar tie on the truss shown.
2. Level and then nail using 2" nails.



CORNER TRIM

Parts Required:

X4	$\frac{3}{8}$ " x 1-3/4" x 75"	
X4	$\frac{3}{8}$ " x 1-3/4" x 76-1/2"	

Fasteners Required:

X56 2" Finish Nails

ASSEMBLY STEPS / NOTES:

1. First - locate 75" trim on the side wall flush to outside of the front wall panel (Fig A, B) and against gable panel (Fig. C) with primed side facing out. Install using 2" finish nails 12" apart.
2. Second - locate 76-1/2" trim flush to the side 75" trim (Fig. B) and flush to the bottom of the wall panel with primed side facing out. Install using 2" finish nails 12" apart.
3. Repeat process at other corners to install all trim pieces.

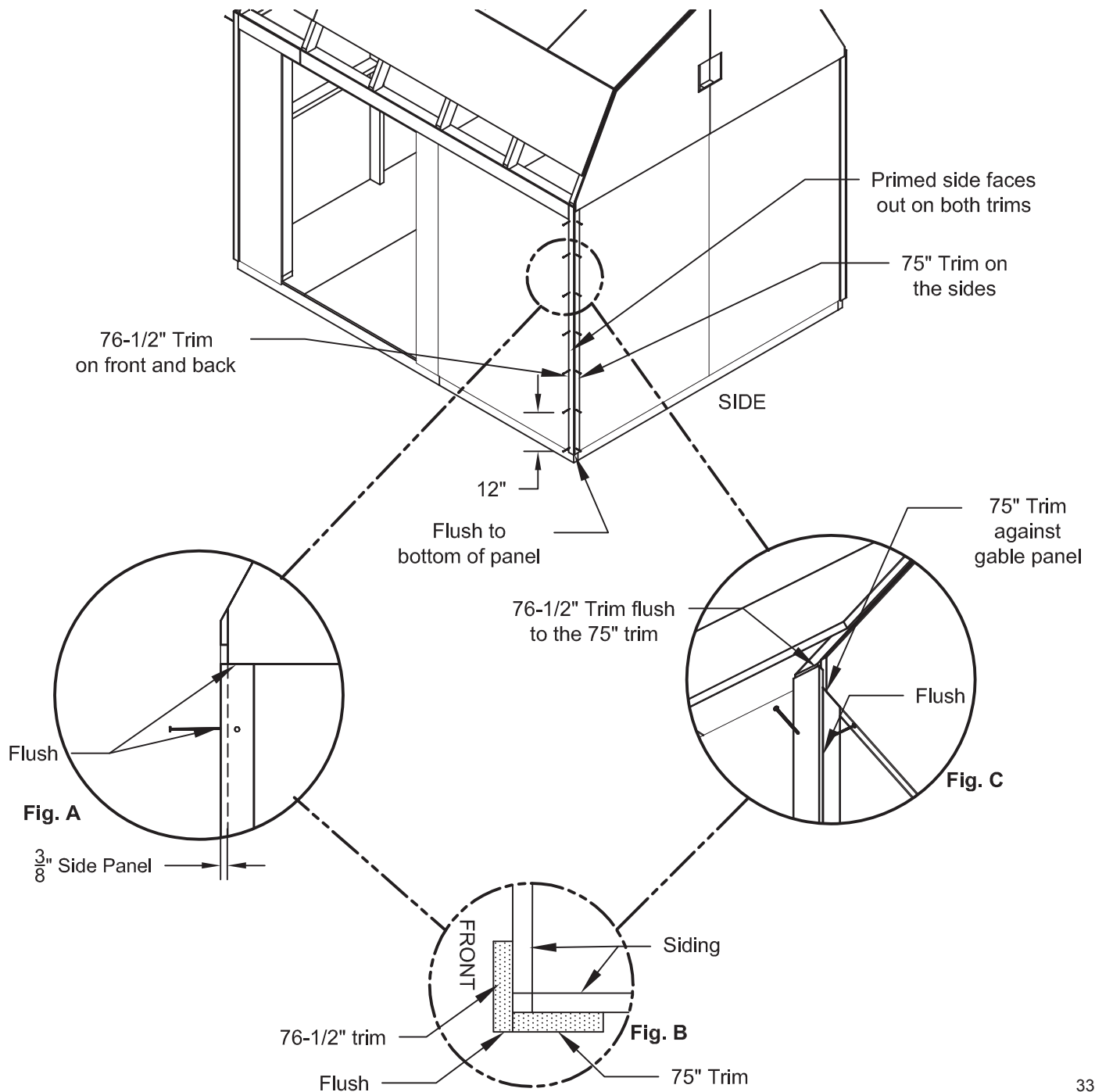

EAVE TRIM

Parts Required:

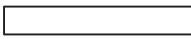
X2	$\frac{3}{8}$ " x 4-1/2" x 96"	
X2	$\frac{3}{8}$ " x 4-1/2" x 22"	

Fasteners Required:

X16 2" Finish Nails

ASSEMBLY STEPS / NOTES:

1. Measure and make several marks along the front of the shed 72" from the bottom of the wall panel (**Fig A**).
2. The 96" trim piece is nailed, primed side out, with 2" finish nails into studs flush against the front corner trim. Also the bottom of the trim on the 72" marks.
3. The 22" trim piece is nailed between the 96" piece and the corner trim with 2" finish nails into the studs. Keep the trim flush at the seam (**Fig B**).
4. Repeat the process on the other side.

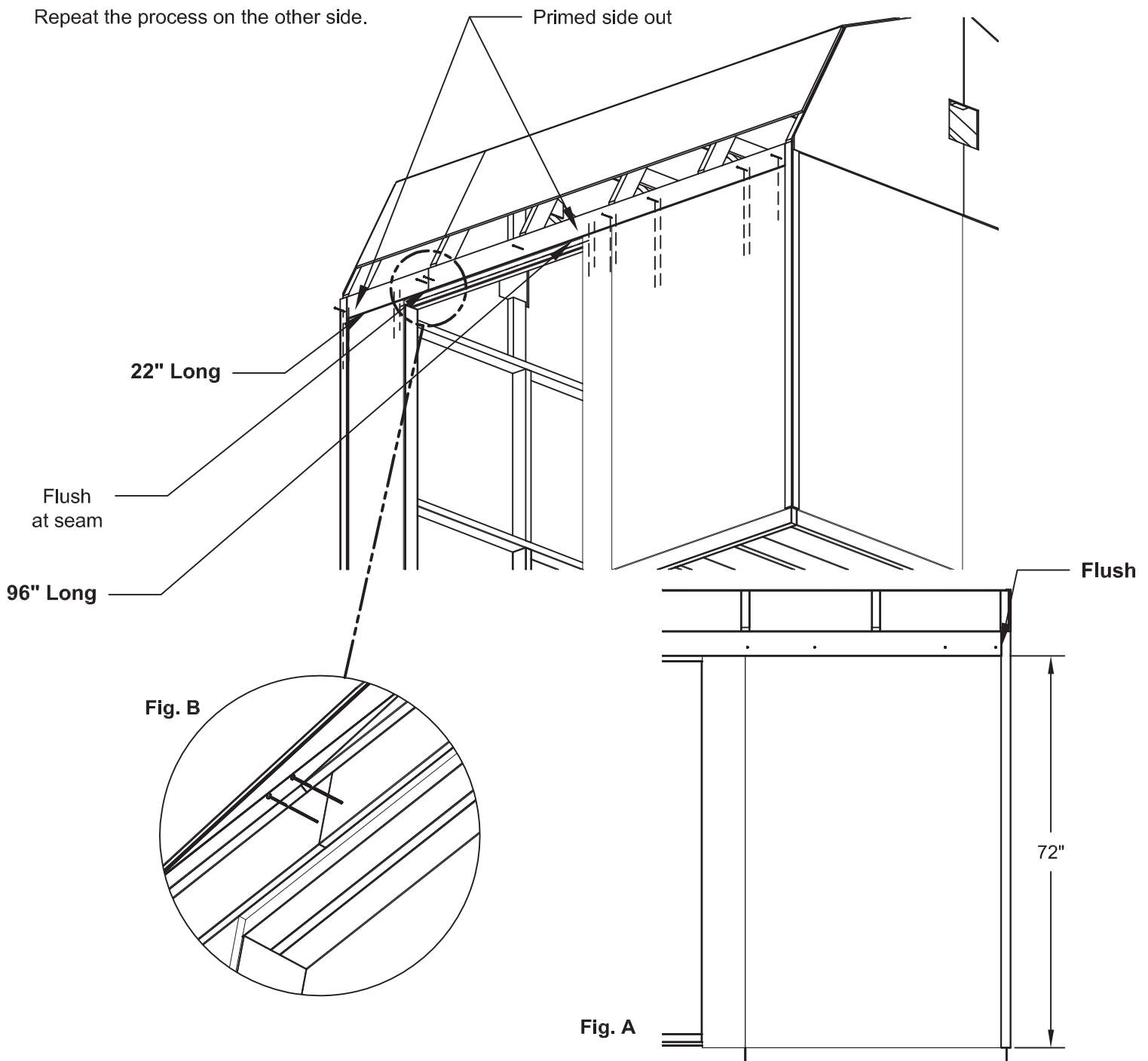

ROOF

Parts Required:

X2 $\frac{7}{16}$ x 11-7/8 x 72" OSB Panel 

X4 $\frac{7}{16}$ x 11-7/8 x 24-11/16" OSB Panel 



Fasteners Required:

X32 2" Nails

ASSEMBLY STEPS / NOTES:

Roof panels may cause serious injury until securely fastened.



1. Attach roof panel 11-7/8" x 72" flush with the installed roof panel, and with a 3/4" measurement on the trusses (Fig J).

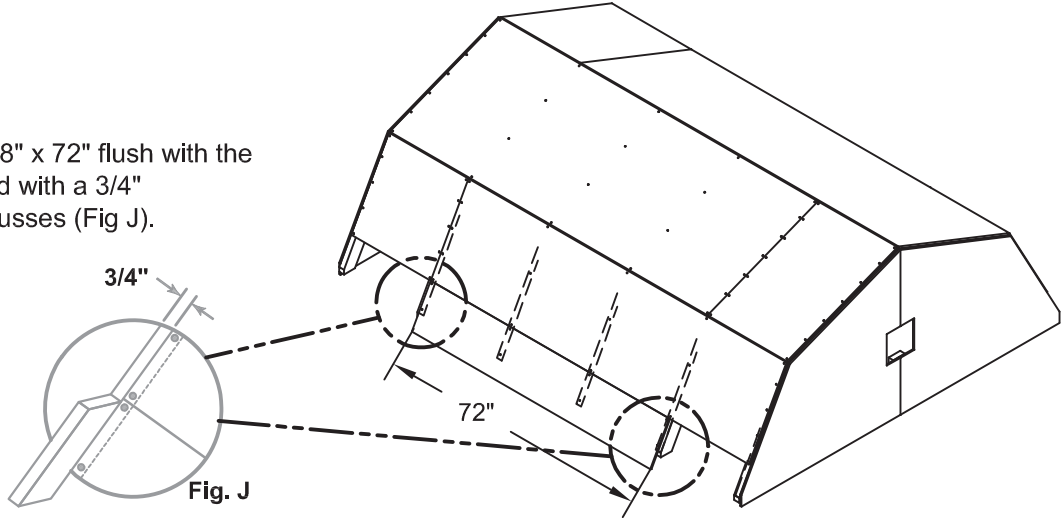

2. Attach the last two roof panels 11-7/8 x 24-11/16 flush with the installed roof panels.



These pieces will be longer than the previously installed panels, flushing out to the face of the gable panels (Fig K). This is to cover the gap between the gable and roof.

3. Repeat process to install roof panels on the opposite side.

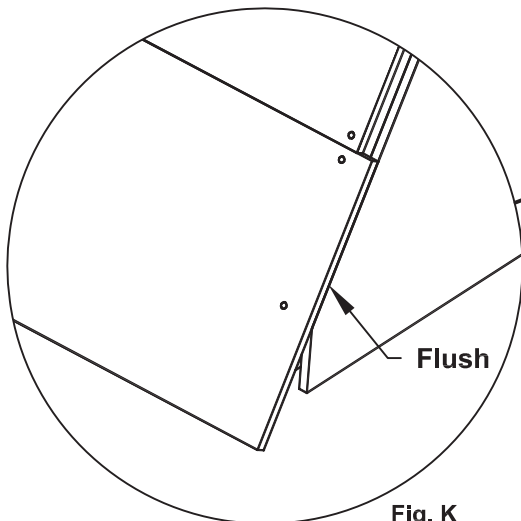
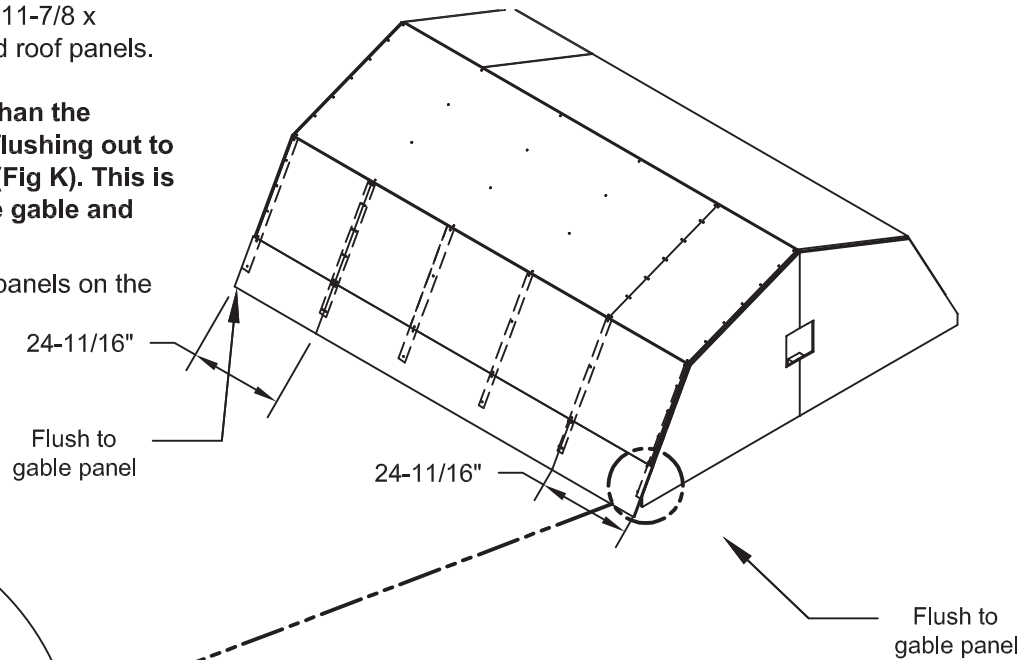

DOORS

Parts Required:

X1 Right Door

X1 Left Door



X1 2 x 3 x 69"

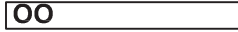

Fasteners Required:

X4 3" Screws

X2 1-1/4" Screws

X32 3/4" Screws

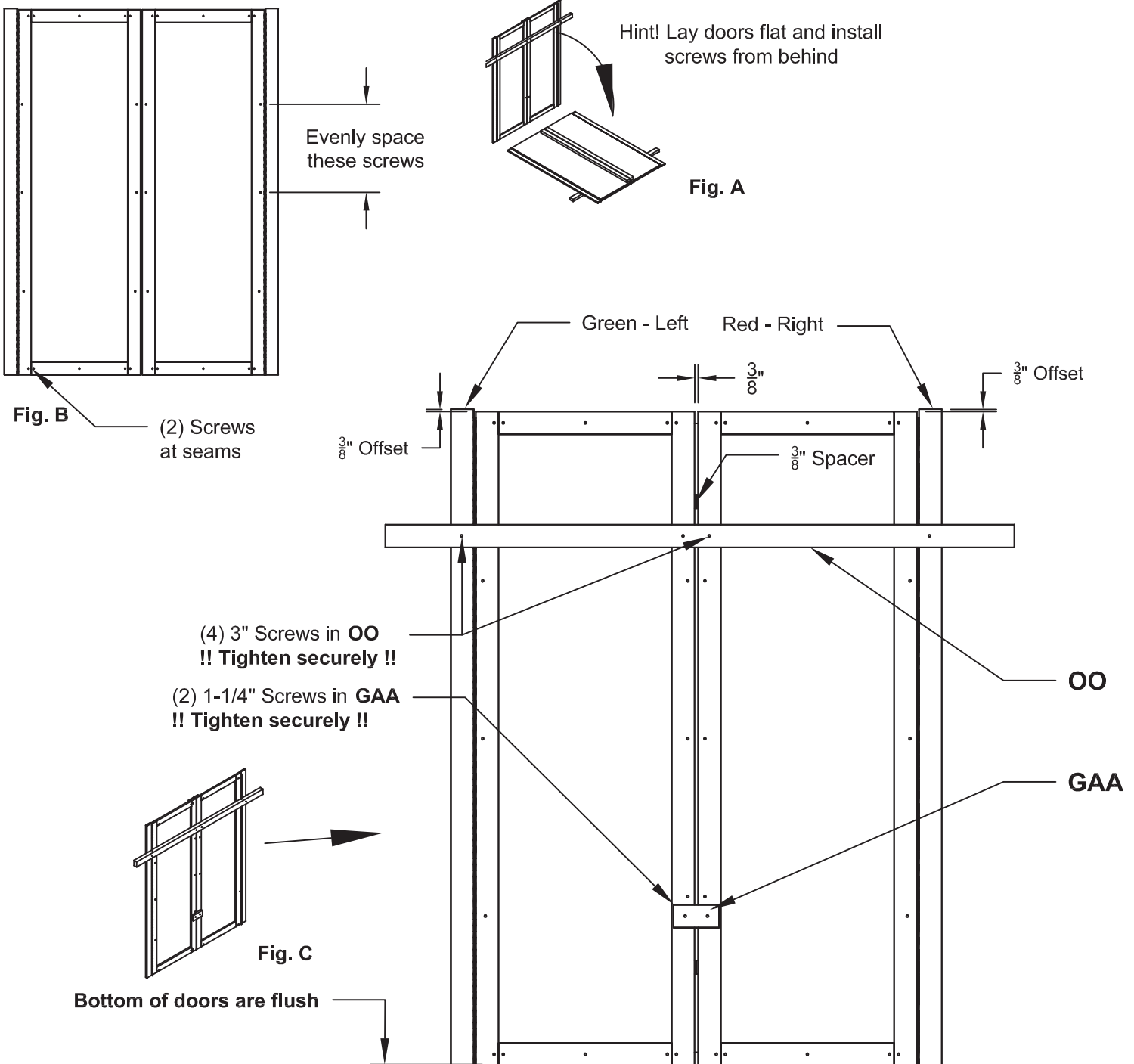

ASSEMBLY STEPS / NOTES:

1. Reinforce the doors using $\frac{3}{4}$ " screws from behind the door into the trim. Hint - lay doors flat (Fig. A) for easier screw installation. Install screws to the pattern shown (Fig B).
2. Flip doors back over and orient the doors together so the $\frac{3}{8}$ " offset is to the same side (Top of door) as shown. Look for GREEN for LEFT door and RED for the RIGHT door. The bottom edges of the doors are flush.
3. Screw on temporary supports across the door trim (Fig C). Use **OO** and **GAA** and tighten screws securely.



DOORS

Parts Required:

X1	$\frac{3}{8}$ x 2 1/2 x 55"	
X1	2 x 3 x 69"	
X1	Door Assembly	

Fasteners Required:

X5	2" Finish Nails
X12	3" Screws

ASSEMBLY STEPS / NOTES:

1. Mark the center of the 48" door opening. Then install **OO** flush under siding using two 3" screws (Fig. A). The doors will rest on **OO** for easier installation
2. Place the door assembly on **OO** with the $\frac{3}{8}$ " gap centered on the mark (Fig. B). Screw hinge boards into wall framing using 3" screws spaced evenly as shown (Fig. C). **!! Make sure screws go into framing !!**
3. Locate over door trim ($\frac{3}{8}$ x 2 1/2 x 55") centered over doors. Secure using five 2" finish nails (Fig. D).
4. Remove the door braces, ledger board and door spacers. Check the doors swing properly.

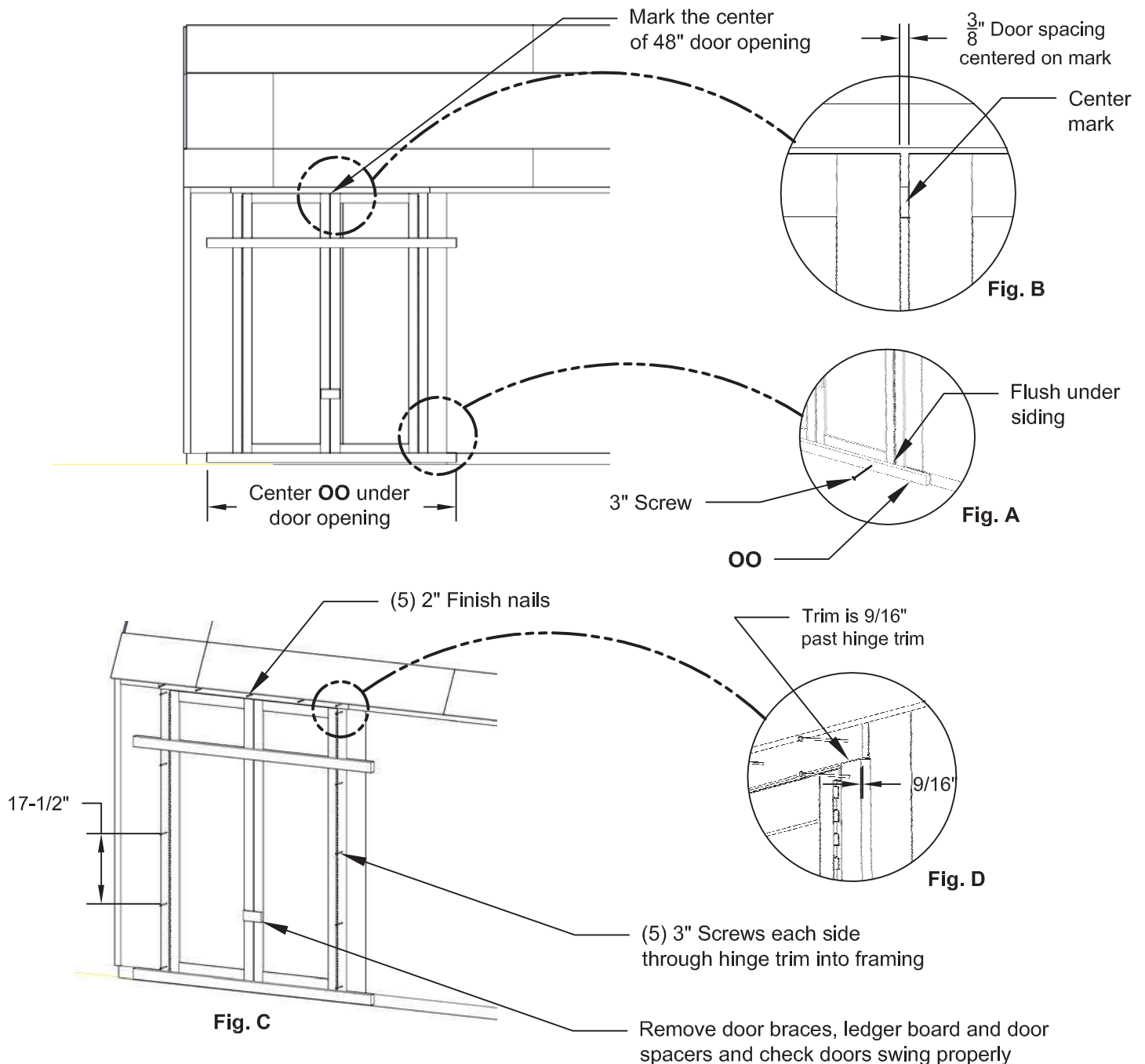

DOORS

Parts Required:

X2	2 x 3 x 69"	OO
X2	1 ⁹ / ₃₂ x 3 x 23"	UWA
X2	1 ⁹ / ₃₂ x 3 x 19"	BEA

Fasteners Required:

X14	2" Screws
X16	3/4" Screws
	(bagged seperately)

ASSEMBLY STEPS / NOTES:

1. With left door closed, center a weatherstrip **OO** vertically on the left door in the door opening (Fig. A). **OO** will offset the left door 1" **OUT** past the door (Fig. B). Secure **OO** using seven 2" screws through outside trim into **OO**.
2. On the right door center **OO** vertically in door opening (Fig. A). **OO** will offset the right door 1" **IN** from the door trim (Fig. C). Secure **OO** using seven 2" screws through outside.
3. Center **UWA** on the lower door trim and secure into from behind the door place using (4) 3/4" screws.
4. Locate **BEA** on top of **UWA** and secure into from behind the door place using (4) 3/4" screws.

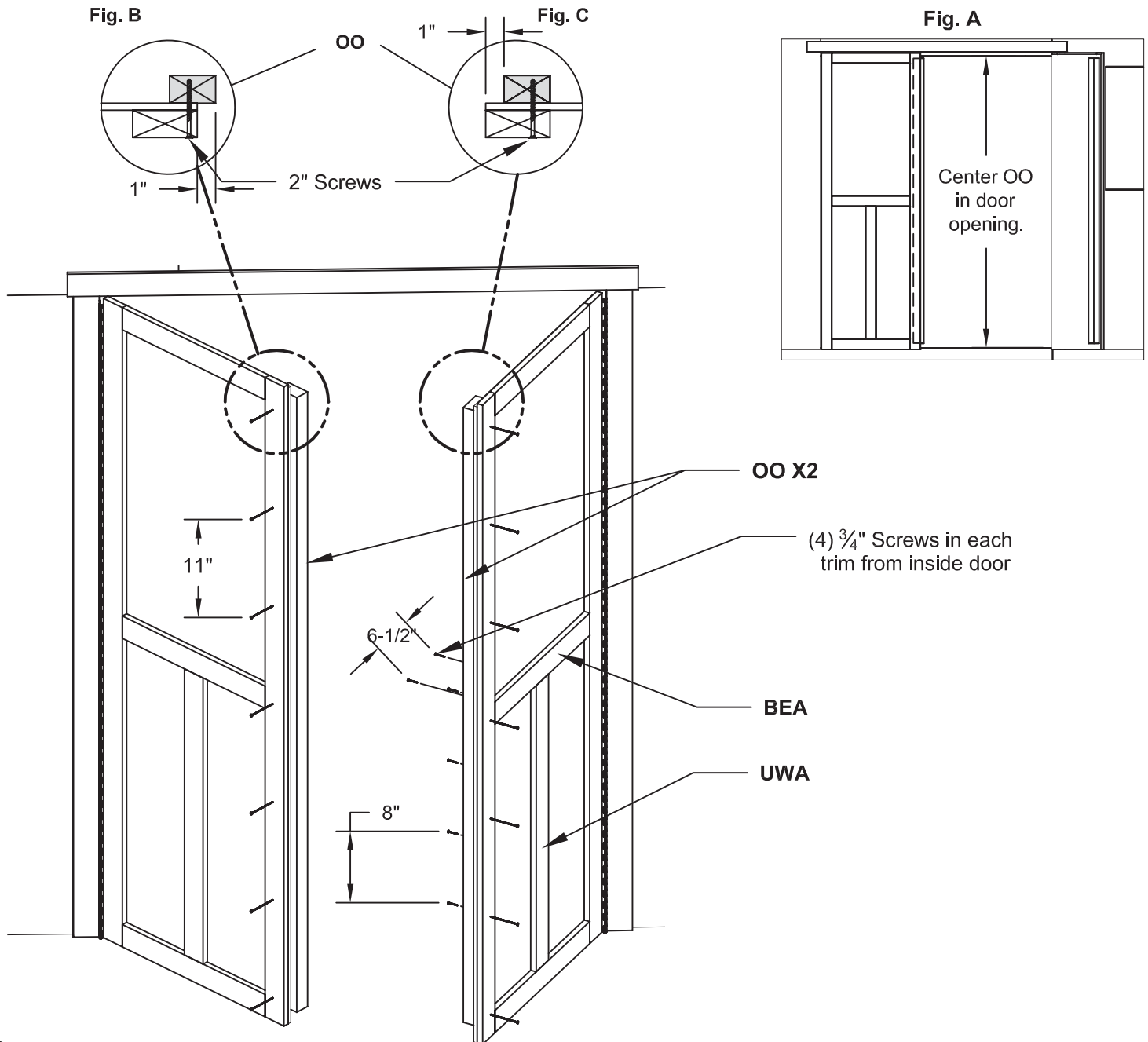

DOORS

Parts Required:

- X2 Spring Loaded Bolts w/Screws
- X1 Door Handle

Fasteners Required:

- X8 1" Screws
- X2 1-1/2" Screws

ASSEMBLY STEPS / NOTES:

1. Place upper bolt onto **OO** in open position with bolt end $\frac{3}{8}$ " down from frame. Bolt is open when loop is contacting base (Fig. A). Mark and pre-drill holes.
2. Install bolt with screws supplied and drill a $\frac{5}{16}$ " hole for bolt to extend into (Fig. A).
3. Place lower bolt onto **OO** in open position with bolt end $\frac{1}{2}$ " up from floor. Bolt is open when loop is contacting base. (Fig.B). Mark and pre-drill holes for screws.
4. Install bolt with screws supplied and drill a $\frac{5}{16}$ " hole for bolt to extend into (Fig. B)
5. Measure up $35\text{-}3/4$ " and drill a $\frac{1}{4}$ " hole thru door and part **OO** (Fig. C). Re-drill the hole larger with a $\frac{1}{2}$ " drill. Be careful to avoid breaking thru **OO**. Attach handle with screws supplied. (Fig. D).

Fig. A

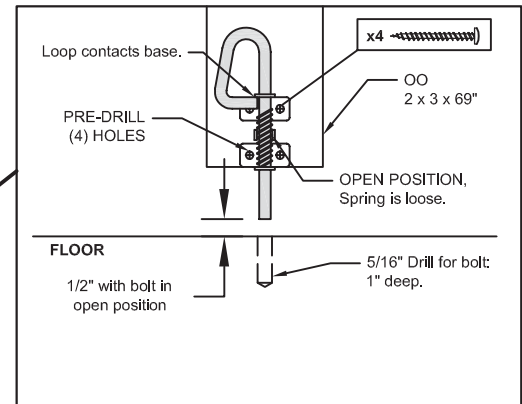
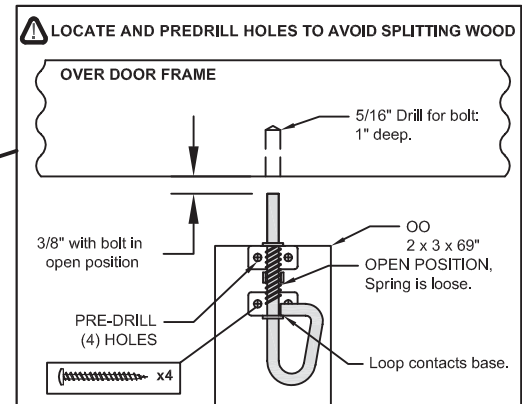
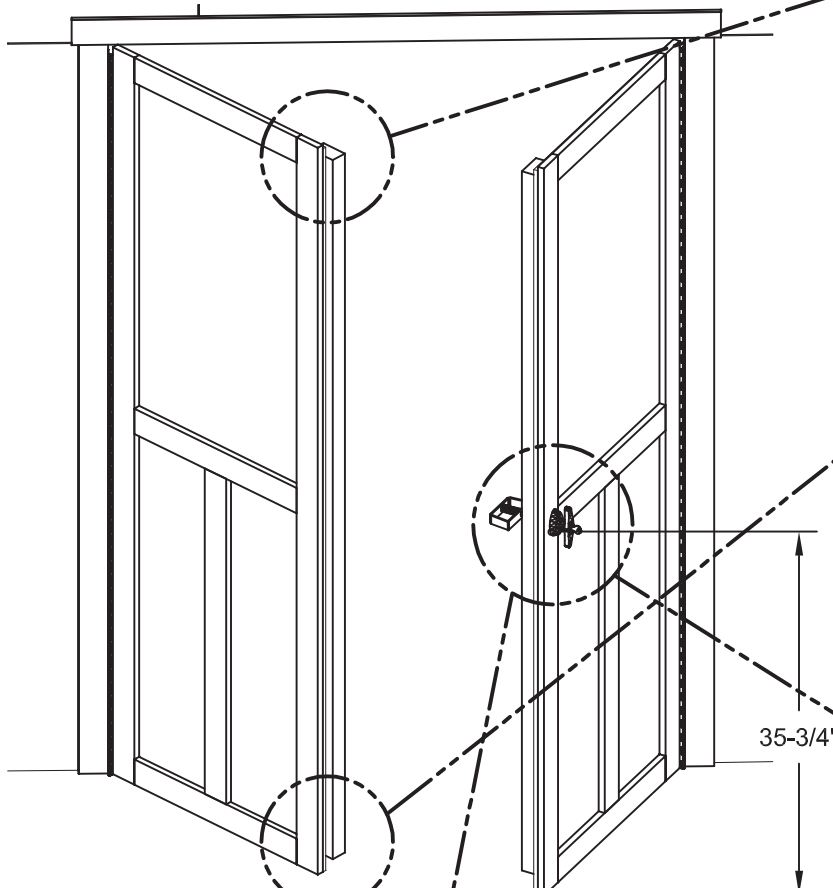

Fig. B



!
Keep drill square to avoid breaking through

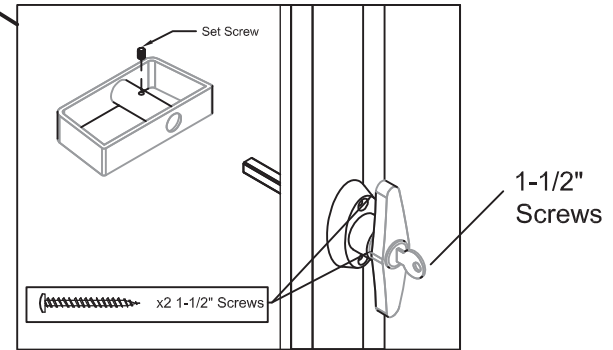
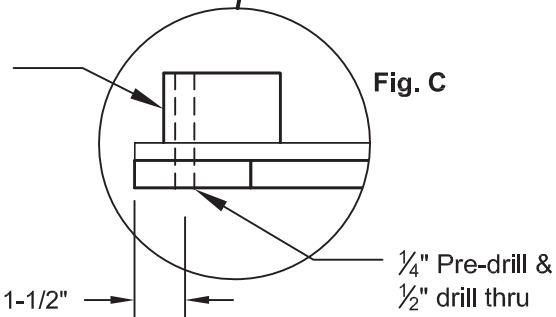

Fig. D

GABLE TRIM

Parts Required:

X2	$1\frac{9}{32} \times 3\frac{1}{2} \times 36\frac{15}{16}$ "	ZLR	
X2	$1\frac{9}{32} \times 3\frac{1}{2} \times 36\frac{15}{16}$ "	ZLL	
X2	$1\frac{9}{32} \times 3\frac{1}{2} \times 36\frac{1}{8}$ "	ZIR	
X2	$1\frac{9}{32} \times 3\frac{1}{2} \times 36\frac{1}{8}$ "	ZIL	
X4	$2 \times 4 \times 36\frac{15}{16}$ "	SCA	Angled End
X4	$2 \times 4 \times 36\frac{1}{8}$ "	SDA	Angled End

Fasteners Required:

X32 2" Nails

ASSEMBLY STEPS / NOTES:

- Nail gable trim (ZLR, ZIR, ZIL, and ZLL) to gable overhang (SCA, SDA) as shown below with 2" nails. The nails will be going through the back side of the trim pieces so the primed side will be facing out when hung on the shed.
- Complete two sets for both sides of the shed.

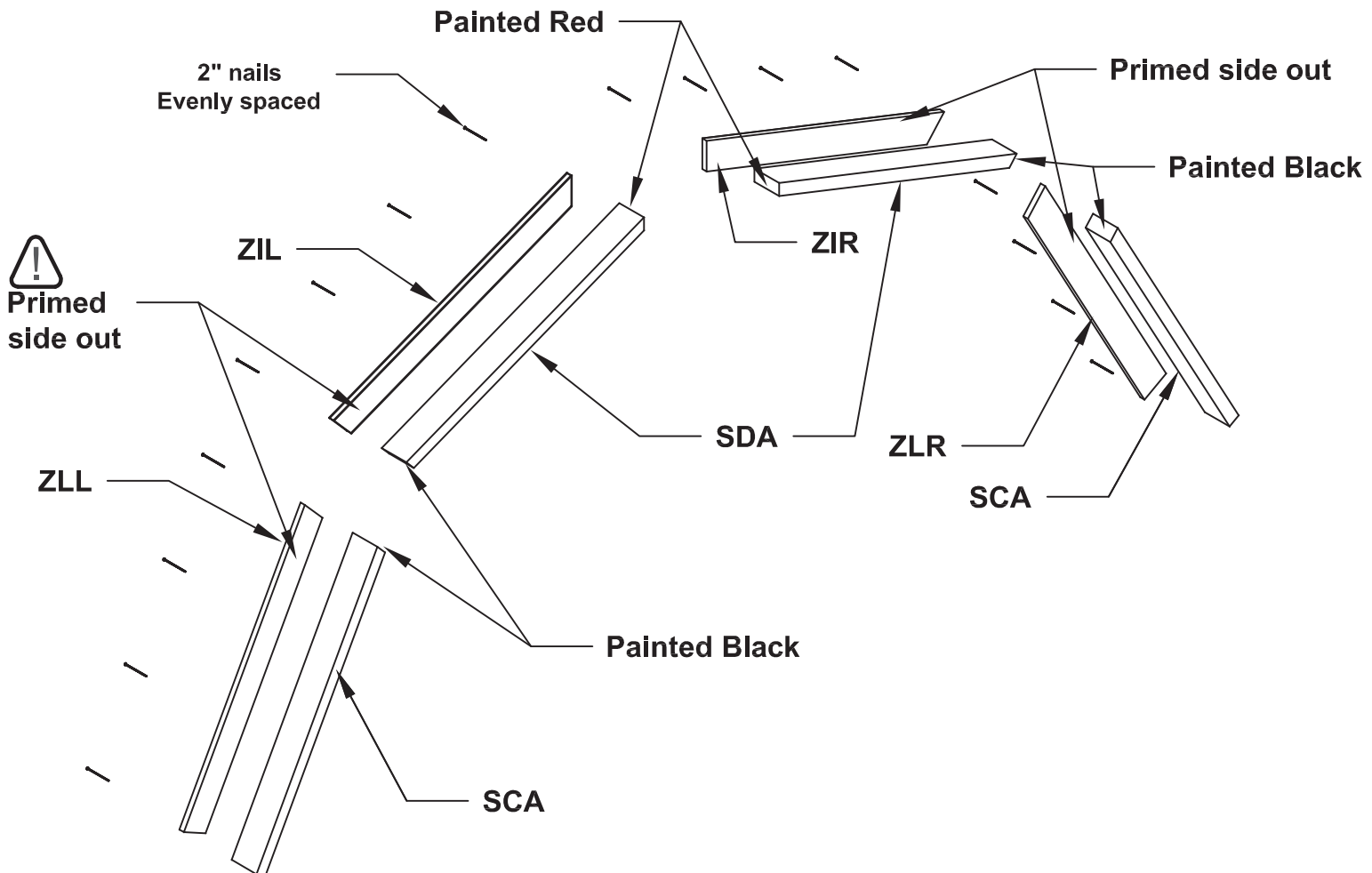

GABLE TRIM

Parts Required:

- X2 Upper Right Trim Assembly
- X2 Upper Left Trim Assembly
- X2 Lower Right Trim Assembly
- X2 Lower Left Trim Assembly

Fasteners Required:

- X32 2" Screws

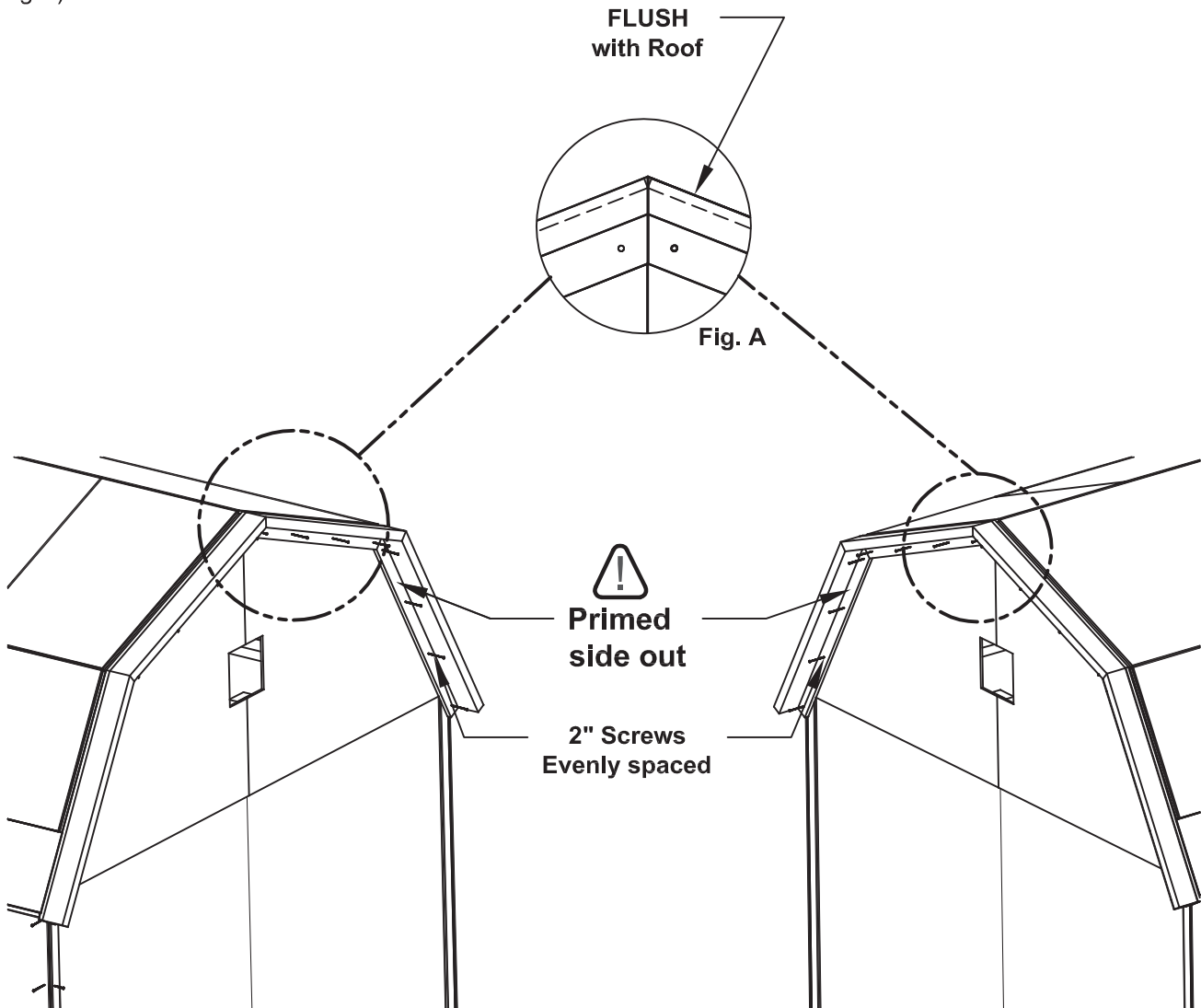

ASSEMBLY STEPS / NOTES:

1. Screw the gable assembly pieces to the sides of the shed with 2" screws. Flush each piece with the roof panels (Fig A).



VENT

Parts Required:

X2	Aluminum Gable Vent		
X4	3/8 x 1-3/4 x 9-5/8"	Vertical Vent Frames	
X4	3/8 x 1-3/4 x 13-1/8"	Horizontal Vent Frames	

Exterior Grade Caulk

Fasteners Required:

X20 3/4" Screws

ASSEMBLY STEPS / NOTES:

1. Caulk back of vent then locate vent in opening flush against siding.
2. Center the vertical vent frame (3/8 x 1-3/4 x 9-5/8") as shown. Screw into place using (2) 3/4" screws each.
3. Place the horizontal vent frame (3/8 x 1-3/4 x 13-1/8") on top and below the vertical frames with the edges flush. Screw into place using (3) 3/4" screws each.
4. Repeat this for both sides of the shed.

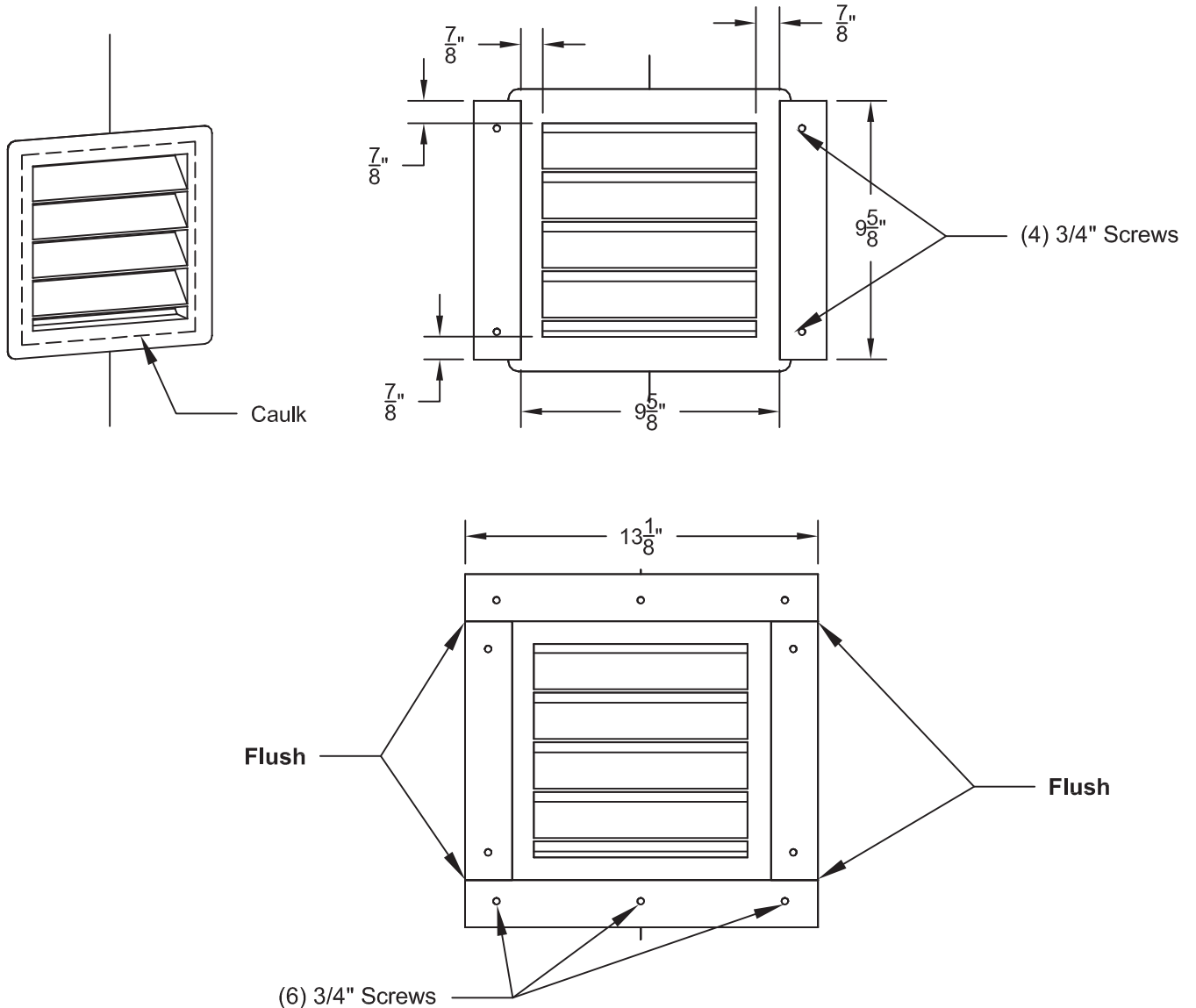

PAINT & CAULK

- NOT INCLUDED -



- Use acrylic caulk that is paintable. Caulk at all horizontal and vertical seams, between the trim and walls, and all around the door trim.
- Use a high quality exterior acrylic latex paint. When painting your building, there are a few key areas that can be easily overlooked that must be painted:
 - Bottom edge of all siding and trim
 - Inside of doors and all 4 edges

Note: Prime all in-primed exterior wood before painting. (Follow directions provided by manufacturer.)

ROOF FELT

- NOT INCLUDED -

- Install felt flush to all roof edges overlapping 3". Use minimal amount of roofing nails to hold in place.

OK to overlap at ridge.

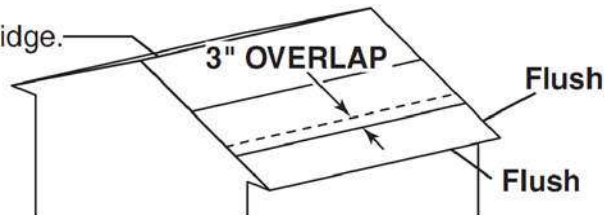

DRIP EDGE

- NOT INCLUDED -



- Install over roof on gable side (**Fig. A**).
- Do not use nails on side of drip edge that hangs over side of building.
- Only nail top of drip edge as shown.

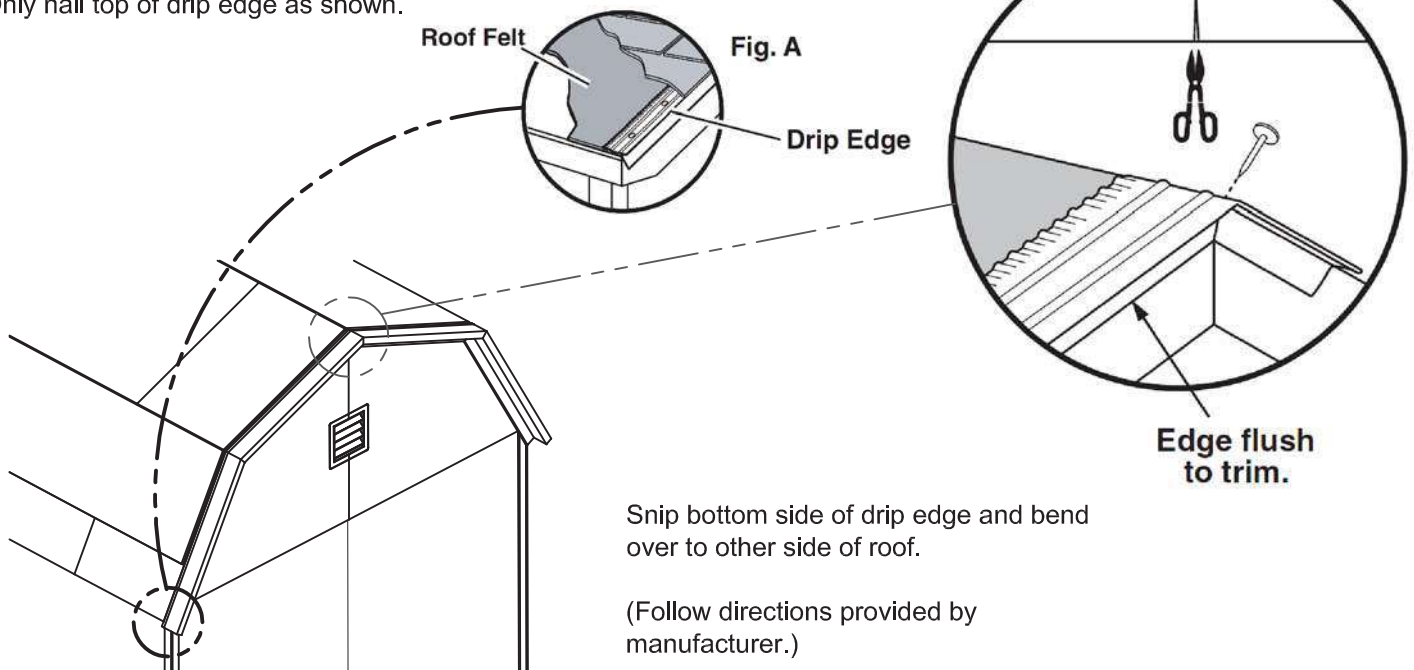

SHINGLES

- NOT INCLUDED -

- Follow directions provided by manufacturer and these instructions.

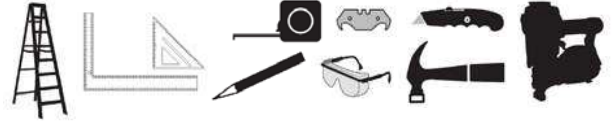

! Familiarize yourself with a 3-Tab Shingle.

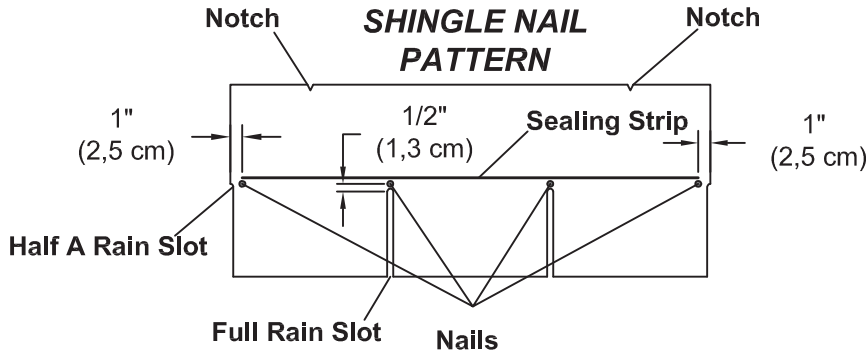

! NEVER DRIVE FASTENERS INTO OR ABOVE SEALING STRIPS.

✓ BEGIN

- Install first starter row upside down and color up with a 1" overhang at back and bottom of roof panel. Use (4) nails per shingle. **Starter row must be straight and level all the way across with lower edge of roof deck.**
NOTE: If you have installed drip edge install shingles flush with drip edge.

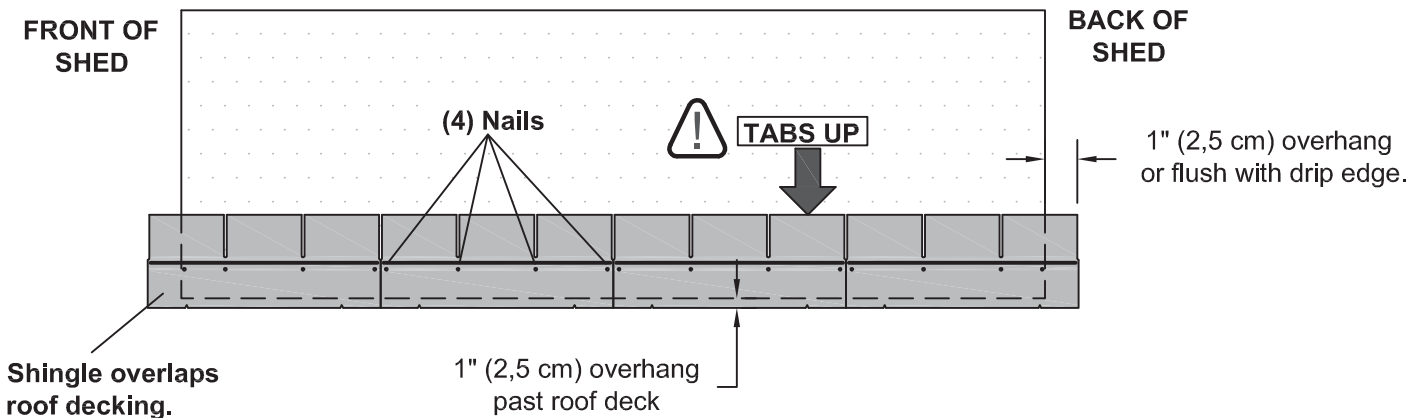

- Beginning at front of shed, install first row of shingles with notch at 1" past roof edge or flush with drip edge.

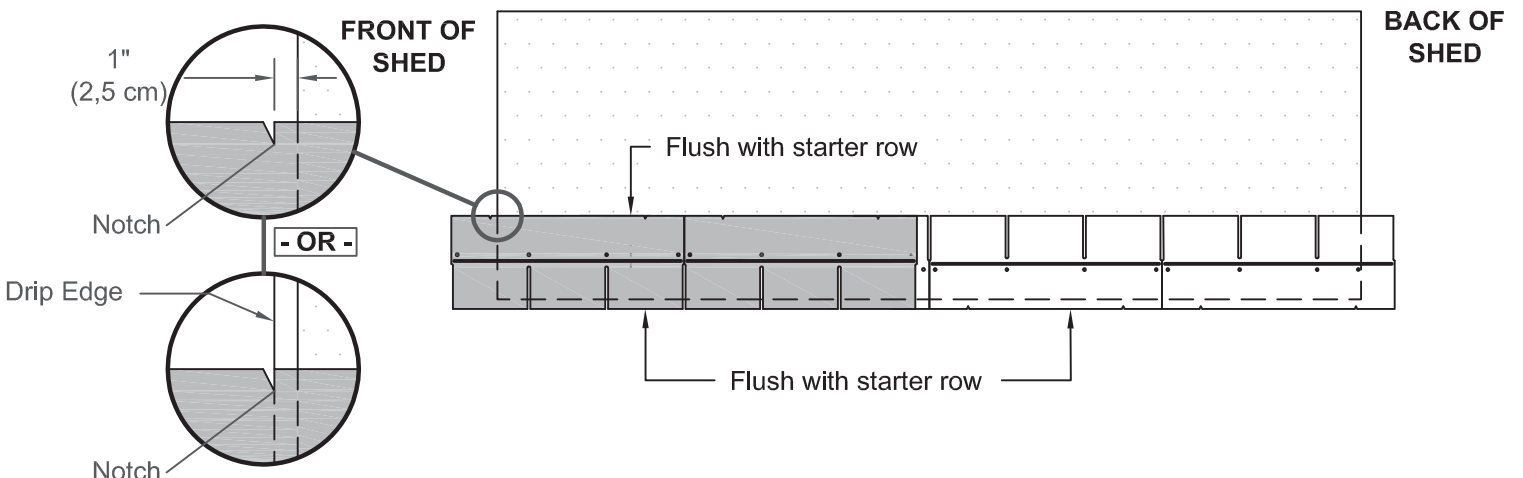

SHINGLES

continued...

3. Install second row of shingles flush at top of first row's rain slots. Ensure 1" overhang or flush to drip edge at front, stagger each row.

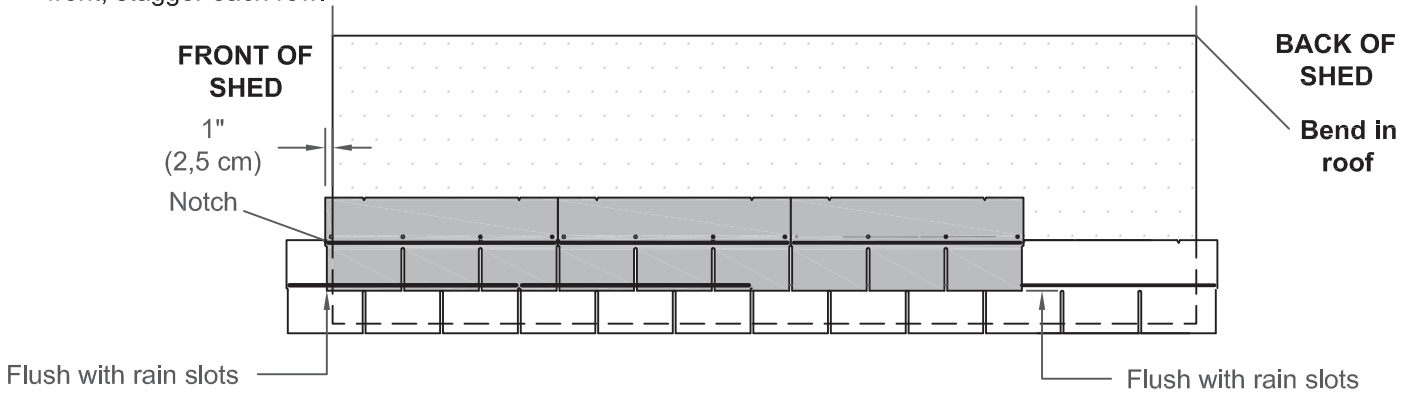

4. Continue installing rows of shingles by staggering at front.

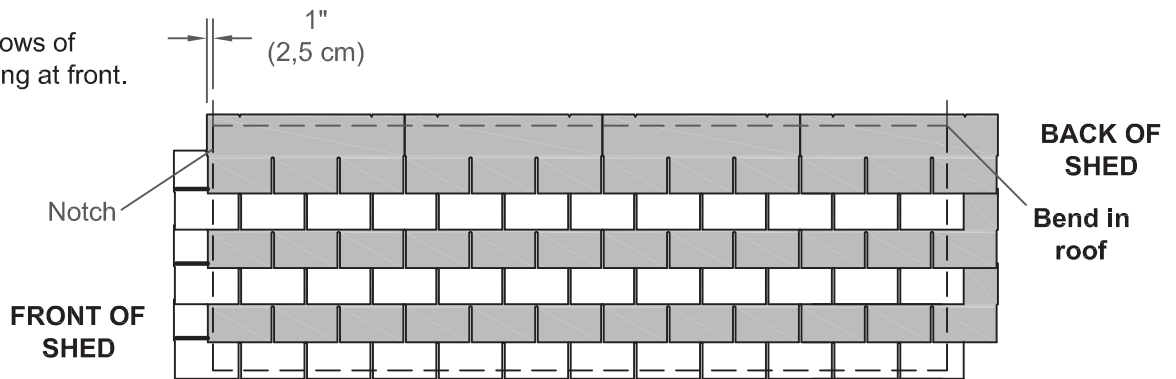

5. The shingle over the bend in the roof will be nailed down. You will need 3" to 4" of this shingle to extend downward over the bend for nailing.

Look for either if the following:

- If the rain slot of the shingle installed over the bend is ABOVE the bend and 3" to 4" of it overhangs down over the bend, continue shingling up to the peak. You have enough to nail the shingle down over the bend.

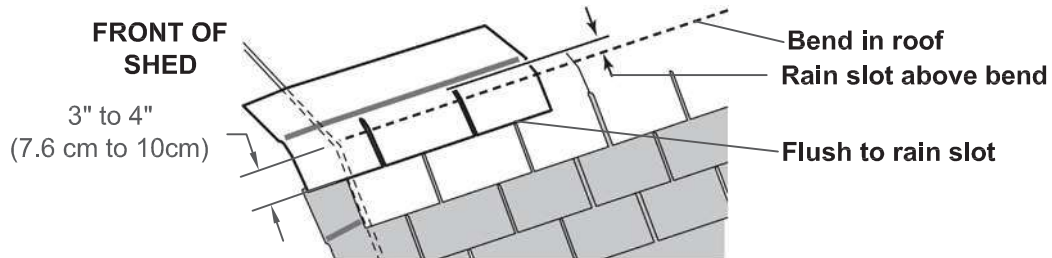

- OR -

- If the rain slot of the shingle installed over the bend is BELOW the bend, install the shingle over the bend and overlap the rain slot to get the 3" to 4" overlap.

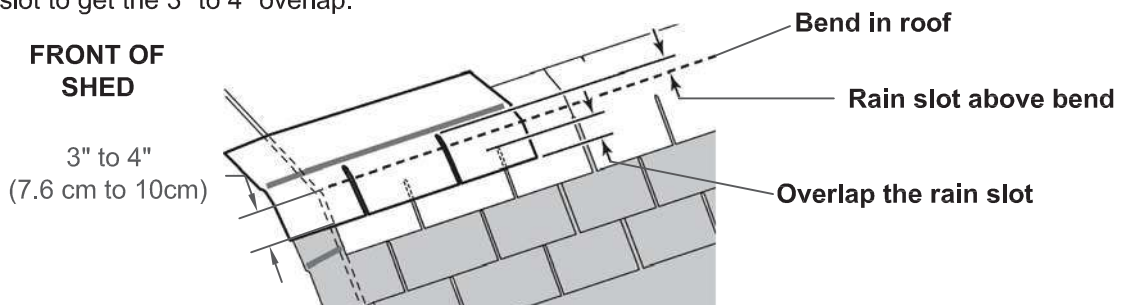

The shingle OVER the bend must be installed with 3" to 4" overlap **AND** the rain slot above the bend.

SHINGLES

continued...

- After shingles are installed over bend, nail down overlap using two roofing nails per tab.

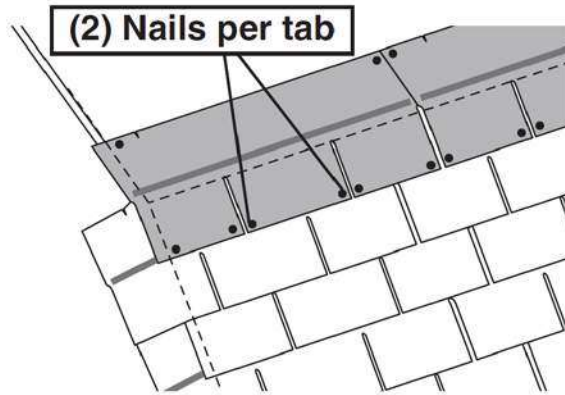

- Continue installing rows of shingles to the peak. At the peak make sure there is a maximum of 5" or less to the rain slot, as shown below. If shingles overlap at ridge cut to peak with a utility knife.

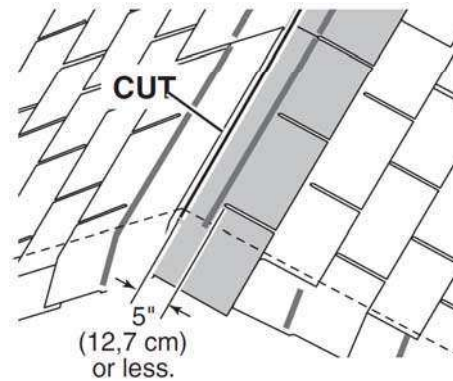
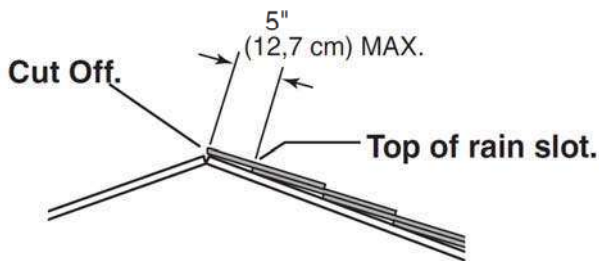

- If more than 5" to rain slot you must install another row of shingles.

- Repeat steps 1 - 7 to shingle the opposite side of your roof. Trim shingles at ridge.
- Once both sides are shingled you need to trim ends. Strike a chalk line 1" from the edge.
- Using your shingle hooked blade carefully cut along the chalk line.

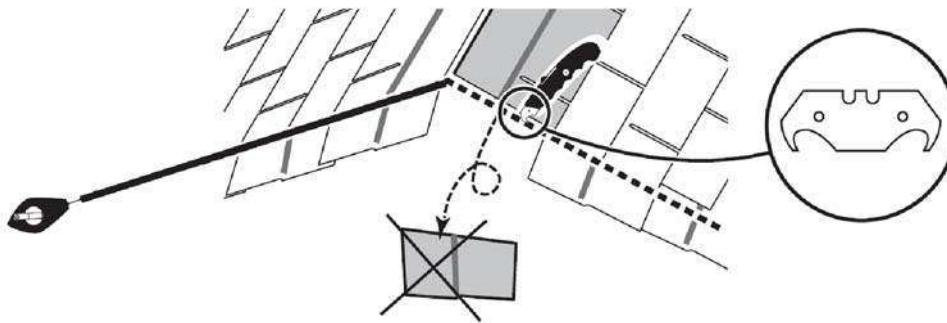

- You have finished shingling your roof. Proceed to capping the ridge.

SHINGLES - RIDGE CAP

- You will finish off the top of the roof with a ridge cap made from shingles.



✓ BEGIN

- Cut shingles into THREE pieces.

Hint: Use cut-off pieces first.

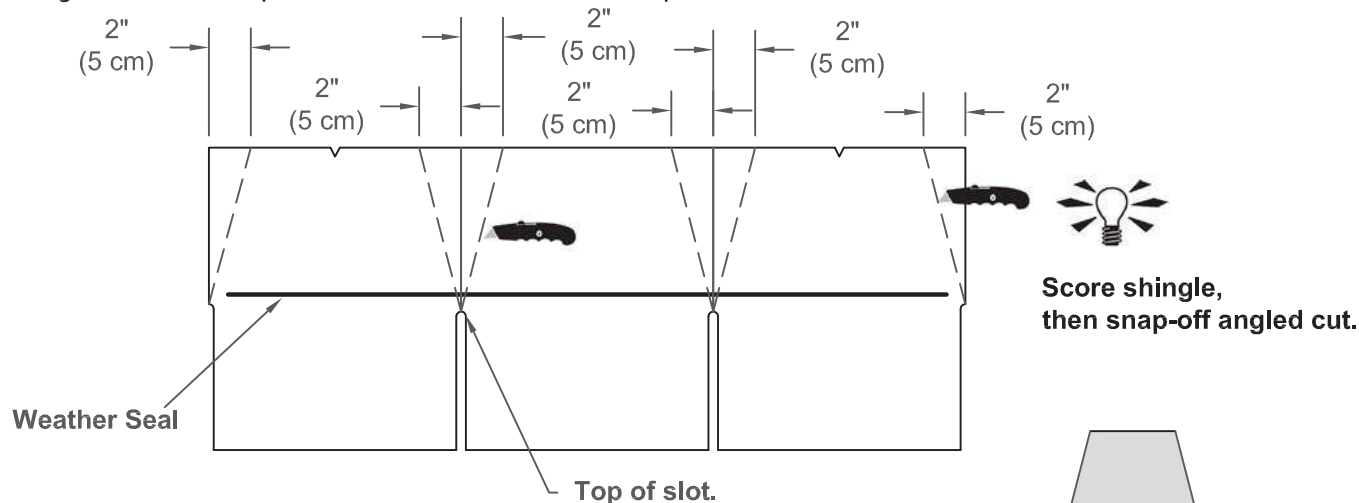

Note: You will need about 20 - 22 cut pieces.



- Install first ridge cap flush to shingles at front, as shown.

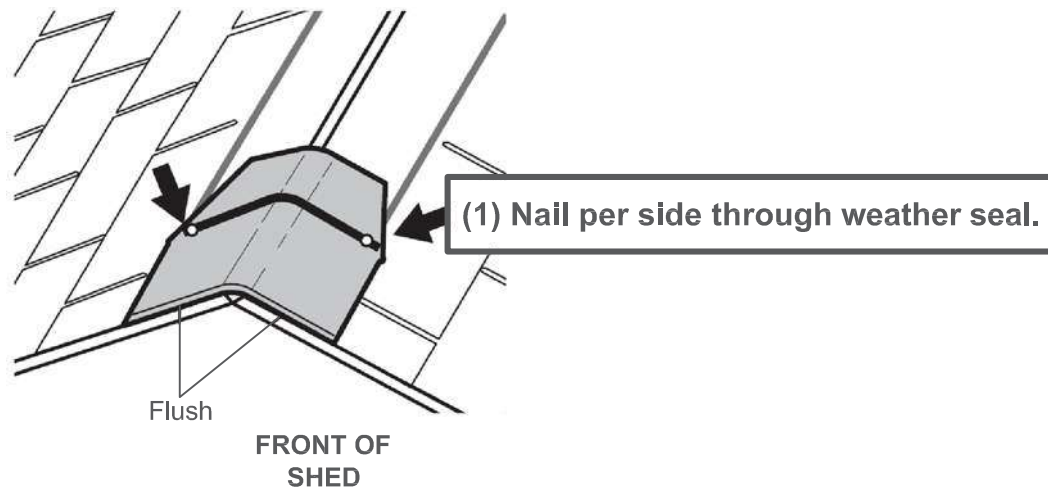

- Install second ridge cap 5" back as shown.

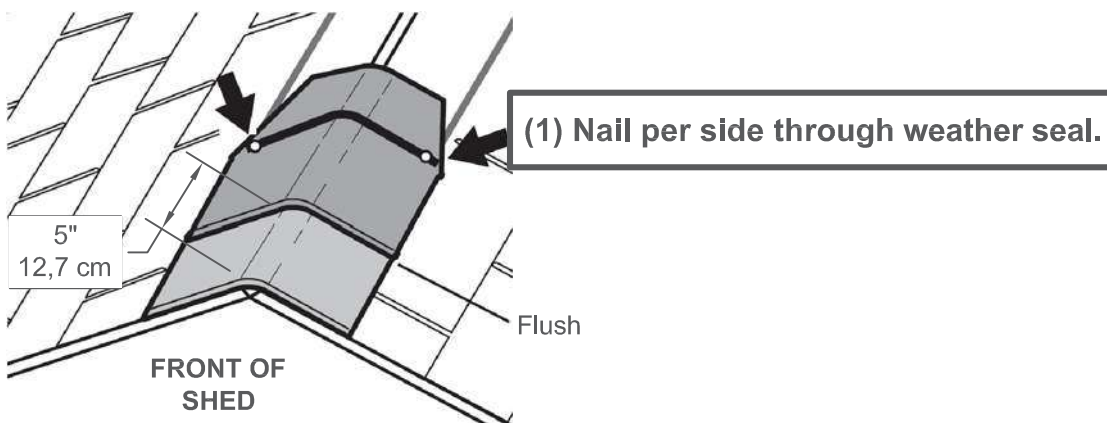

SHINGLES - Ridge Cap

continued...

4. Continue installing ridge cap to back of roof.

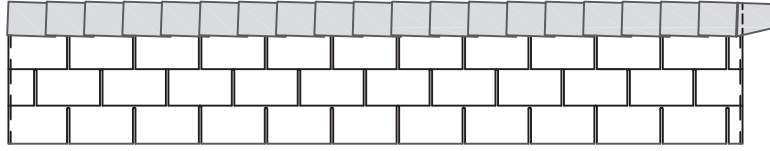

5. Make sure there is 4" between the shingle color and edge of shingles.

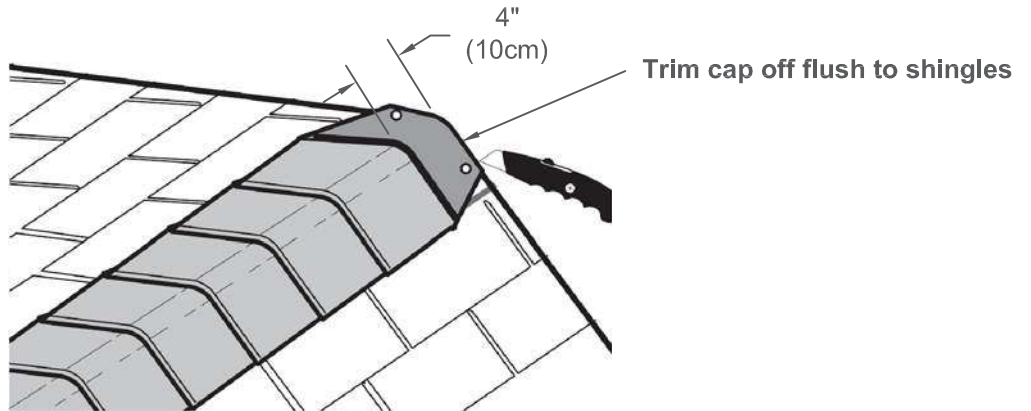

6. When you have 4" minimum of shingle color cut one piece to cap your roof.

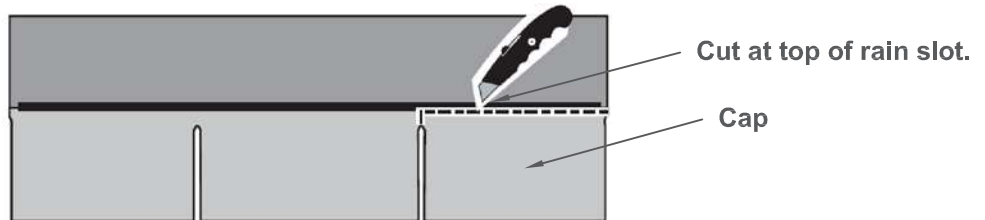

7. Install flush to shingles.

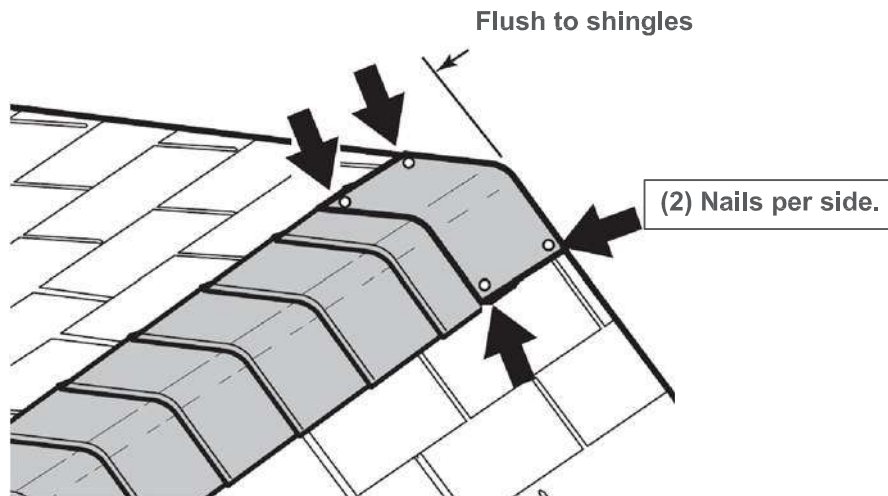

8. You have finished your ridge cap.

WARRANTY

Backyard Storage Solutions, LLC warrants the following:

1. Every product is warranted from defects in workmanship and manufacturing for one year.
2. All hardware and metal components are warranted for two years.
3. Trim is warranted for 10 years.
4. Waferboard siding and sheathing is warranted for two years.
5. SmartSide™ siding is warranted for 10 years on all Marco series buildings and 15 years on all Premier Series buildings.
6. Timber series buildings' siding and trim are warranted for 10 years.
7. Solar Shed windows are warranted for 1 year.
8. Cedar lumber is warranted for 15 years.
9. Cedar doors and Cedar Garden Center are warranted for 10 years.
10. Metal roof is warranted for 25 years.

**Limited Conditional
Warranty ***

Backyard Storage Solutions, LLC will repair, replace or pay for the affected part. In no event shall Backyard Storage Solutions, LLC pay the cost of labor or installation or any other costs related thereto. All warranties are from date of purchase. If a cash refund is paid on an affected part, it will be prorated from the date of purchase.

CONDITIONS

The warranty is effective only when:

1. The unit has been erected in accordance with the assembly instructions.
2. The unit has been properly shingled and painted or stained and reasonably and regularly maintained thereafter.
3. The failure occurs when the unit is owned by the original purchaser.
4. Backyard Storage Solutions, LLC has received the warranty registration card within thirty (30) days of purchase and notification of the failure in writing within the warranty period specified above.
5. Backyard Storage Solutions, LLC has had reasonable opportunity during the sixty (60) days following receipt of notification to inspect and verify the failure prior to commencement of any repair work.

REQUIREMENTS

Storage Buildings & Playhouses

To validate your warranty, it is necessary to properly maintain your Backyard Storage Solutions, LLC unit; shingle the roof and paint or solid-colored stain the siding using 100% acrylic latex exterior product with a minimum of two (2) coats within thirty (30) days of assembly; caulk above all doors and all horizontal and vertical trim boards; paint and seal all exposed edges, sides and faces of SmartSide™ and waferboard siding to include all exterior walls and all sides and all edges of doors.

Gazebos, Pergolas & Timber Buildings

To validate your warranty, it is necessary to properly maintain your Backyard Storage Solutions, LLC unit. This includes treating all of the exposed cedar and pine surfaces on your gazebo or timber building with an exterior grade wood preservative, an exterior oil-based semi-transparent stain, an acrylic latex exterior paint or an acrylic latex solid color exterior stain within 30 days of assembly and as needed thereafter to maintain your warranty.

Keep vegetation trimmed away from building and make sure siding panels and trim do not come in contact with masonry or cement. The minimum ground clearance for siding must be one half inch (½ inch) from concrete slab or two and one half inches (2 ½") from the ground when building is erected or constructed on a treated wood floor kit. Water from sprinklers must be kept off unit. In no event will Backyard Storage Solutions, LLC be responsible for any indirect, incidental, consequential or special damages nor for failure(s) that are caused by events, acts or omissions beyond our control including, but not limited to, misuse or improper assembly, improper maintenance (which eventually leads to rot or decay) and acts of God. Backyard Storage Solutions, LLC will not be held responsible for any labor costs incurred to construct your unit. This warranty gives you certain specific rights that vary from state to state.

CLAIM PROCEDURE

To make a claim under this warranty, you can either call 1-888-827-9056 or prepare a letter. Please have ready the information below when you call or include the information when writing:

1. The model and size of the product.
2. A list of the part(s) for which the claim is made.
3. Proof of purchase of the Backyard Storage Solutions, LLC item, as shown on the original invoice.
4. Run code, as listed on the yellow warranty card enclosed in the product package.

Mail the above information to:

Backyard Storage Solutions, LLC
Attn: Customer Service
1000 Ternes
Monroe, MI 48162

***WARRANTY TERMS MAY VARY OUTSIDE THE U.S.A.**

IMPORTANT: This is your warranty certificate.

Please complete and mail your warranty card to properly validate your warranty.