

# Cedar Table - Model 24 Assembly Manual

Revision #9  
January 20, 2021

Estimated Assembly Time for  
the Cedar Table = 2 Hours

Thank you for purchasing a Cedar Table.  
Please take the time to  
identify all the parts prior to  
assembly.



Please use Safety Eye wear and Gloves while  
Assembling. Be sure to read and  
follow all operating instructions for any tools  
used during assembly.  
Remember- NO SAW CUTTING IS REQUIRED!

**Safety Points and Other Considerations**  
Our products are built for use based on proper  
installation and normal residential use, on level  
ground.  
Please follow the instruction manual when  
assembling your Cedar Picnic Table and retain  
the manual for future maintenance purposes.

**Weathering and Seasoning Characteristics**  
Western Red Cedar lumber, when exposed to the  
elements, will turn a silvery grey color within 1  
year. Seasoning splits in the surface of the wood  
can also occur.  
Many customers prefer the natural beauty of  
cedar wood but if you prefer to limit these  
characteristics from occurring, we recommend  
staining or painting the wood prior to assembly.  
Please do a rough sand using 100 grit sand  
paper first.

-Have a regular maintenance plan to ensure all  
components are screwed together tight.

## Cedar Table Dimensions:

A: Table Height = 30 3/4"  
B: Table Width = 34" to 34 1/4"  
C: Table Length = 66"  
D: Bench Height = 17 1/2"  
E: Bench Width = 11 1/4"  
F: Bench Length = 66"  
G: Overall Width = 64 3/4"

## Important:

Once assembled, check and tighten  
carriage bolts as required. Wood may  
shrink over time causing the table to  
loosen somewhat.

In the event of a missing or broken piece, simply call the Outdoor Living Today Customer Support  
Line @ 1-888-658-1658 within 30 days of the delivery of your purchase. It is our commitment to you  
to courier replacement parts, free of charge, within 10 business days of this notification.  
Replacement parts will not be provided free of charge after the 30 day grace period.

# Exploded View and Parts List for Cedar Table

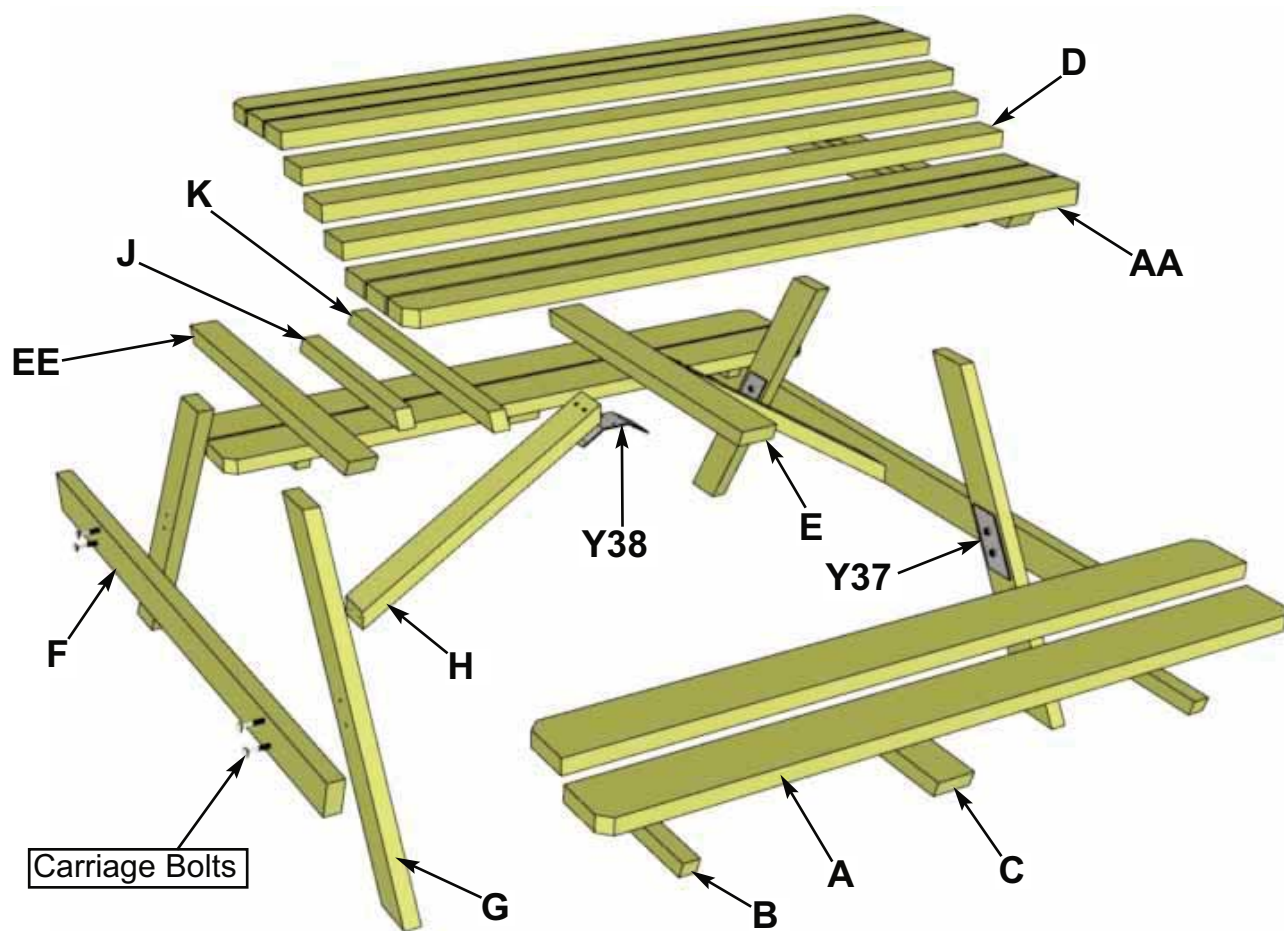

**Important:** When unpacking your Table from the shipping box, be sure to inventory all parts. If you discover missing or damaged pieces, please call our Toll Free Customer Support Line @ 1-888-658-1658 for fast and courteous Customer Service.

**Note:** Use Cardboard from the Shipping Box to lay on the ground while assembling your Picnic Table to avoid scratching wood surfaces.

Thank you for purchasing one of our Cedar Picnic Tables. Please take the time to identify all the parts prior to assembly.

Parts Lists:	Finished Size			Qty.
	T	W	L	
<b>A - Bench Boards</b> (Angled Corners on one side)	1 1/2"	5 1/2"	66"	4
<b>AA-Table Top Outside Boards</b> (Angled Corners on one side)	1 1/2"	3 1/2"	66"	2
<b>B - Bench Cleats - End</b>	1 1/2"	1 1/2"	9 1/2"	4
<b>C - Bench Cleats - Middle</b>	1 1/2"	3 1/2"	9 1/2"	2
<b>D - Table Top Boards</b>	1 1/2"	3 1/2"	66"	7
<b>E - Table Top Cleat - Middle</b>	1 1/2"	3 1/2"	33 1/2"	1
<b>EE - Table Top Cleats - End</b>	1 1/2"	2 1/2"	33 1/2"	2
<b>F - Bench Supports</b>	1 1/2"	3 1/2"	62 1/2"	2
<b>G - Legs</b>	1 1/2"	3 1/2"	33 3/4"	4
<b>H - Angle Brackets</b>	1 1/2"	3 1/2"	27 7/8"	2
<b>I - Spacer Blocks (not shown)</b>	3/8"	2"	2"	16
<b>J - Leg Cleats - End</b>	1 1/2"	1 1/2"	20"	2
<b>K - Leg Cleats - Middle</b>	1 1/2"	1 1/2"	28"	2

**Specifications:**  
 Wood Species - Western Red Cedar  
 Grade - Architectural Knotty or Better  
 Carriage Bolts & Washers - Zinc Plated  
 2 1/2" Screws - Brown MagnaGuard

# CEDAR TABLE HARDWARE PACKAGE

## Hardware Kit (Provided)

S1 - 2 1/2" Screws  x 136

S2 - 1 1/4" Screws  x 7

BR1 - Square Drive Bit  x 1

BC1 - 5/16" Carriage Bolts  x 8

NU1 - 5/16" Nuts  x 8

WA2 - 5/16" Washers  x 8

Y37 - 3" x 6" Reinforcement Bracket  x 4

Y38 - Middle Reinforcement Bracket  x 1

## Tools Required (Not Provided)



Screw Gun/Drill



Tape Measure



Wood Clamp



1/2" Wrench



Pliers



Level



1/8" Drill Bit

## Safety Equipment Required (Not Provided)



Safety Glasses



Work Gloves

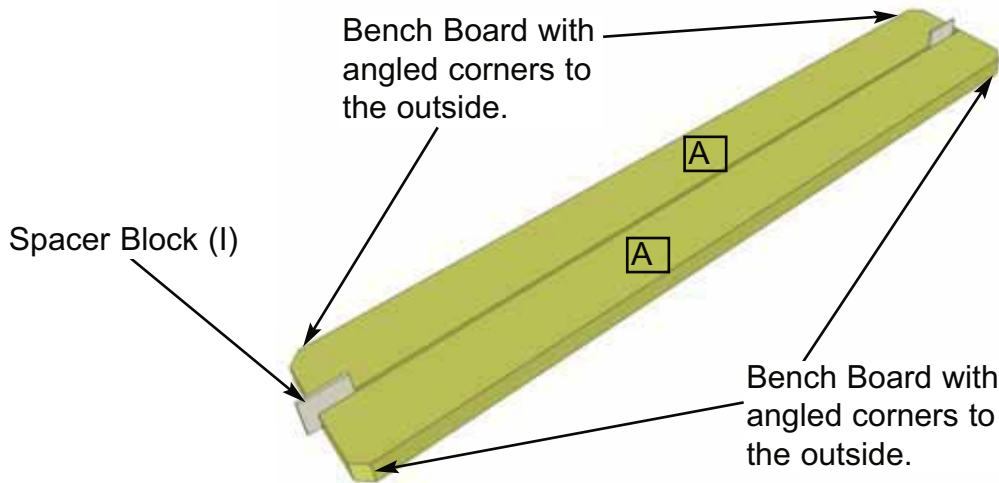

**1.** Start by inspecting all **Bench Boards**. There are 4 pieces with angle cut corners on 1 side. Lay 2 pieces down on a flat smooth surface. We suggest laying the cardboard packaging underneath to prevent unnecessary scratching of the wood surface. Place best face to the ground as Picnic Table will be flipped over when assembly is complete. Locate **Spacer Blocks** and slide between both Bench Board Pieces.

Parts	
<b>A - Bench Boards</b>	(1 1/2" x 5 1/2" x 66") x 4
<b>I - Spacer Blocks</b>	(3/8" x 2" x 2") x 4

**Important:** Choose Bench Boards for Quality and Color. Place Best Face Down as Table will be flipped over when Assembly is complete.

**Important:** Pilot hole prior to screwing with 1/8" Drill Bit to prevent wood from slitting.

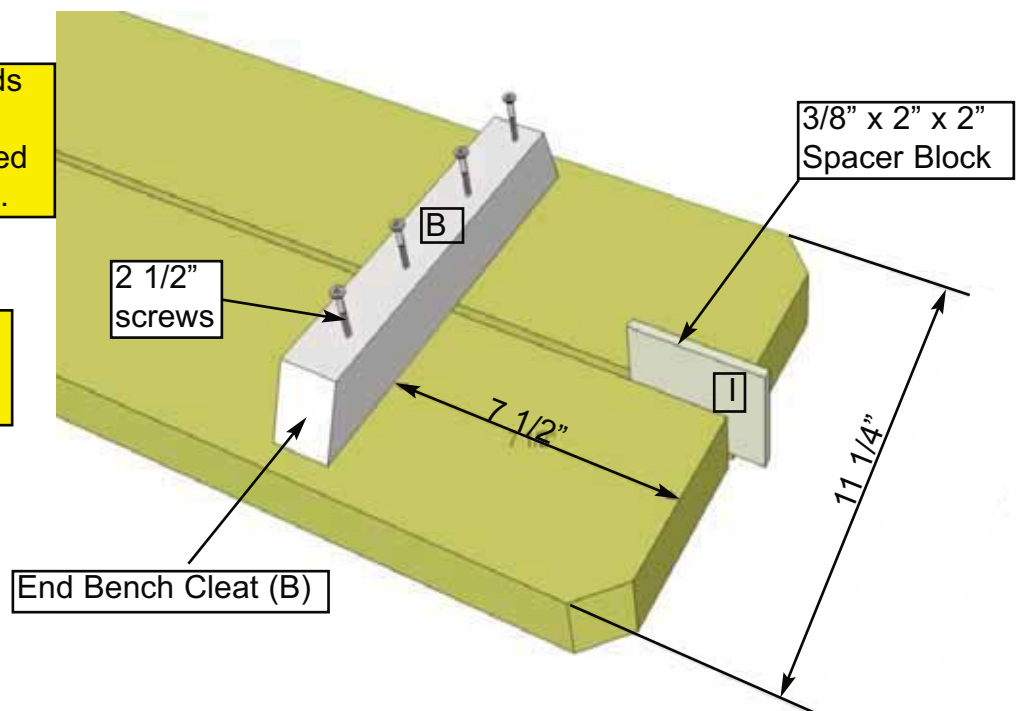

**2.** Measure 11 1/4" wide with Bench Boards and Space Blocks tight together. Attach **End Bench Cleat** 7 1/2" from the end with **4 - 2 1/2" Screws**. Center Clear from side to side. Do not fasten screws completely until **Step 3**.

Parts (Steps 2 - 3)	
<b>B - End Bench Cleats</b>	(1 1/2" x 1 1/2" x 9 1/2") x 4
<b>C - Middle Bench Cleats</b>	(1 1/2" x 3 1/2" x 9 1/2") x 2

Hardware (Steps 2 - 3)	
<b>S1 - 2 1/2" Screws</b>	x 24 total

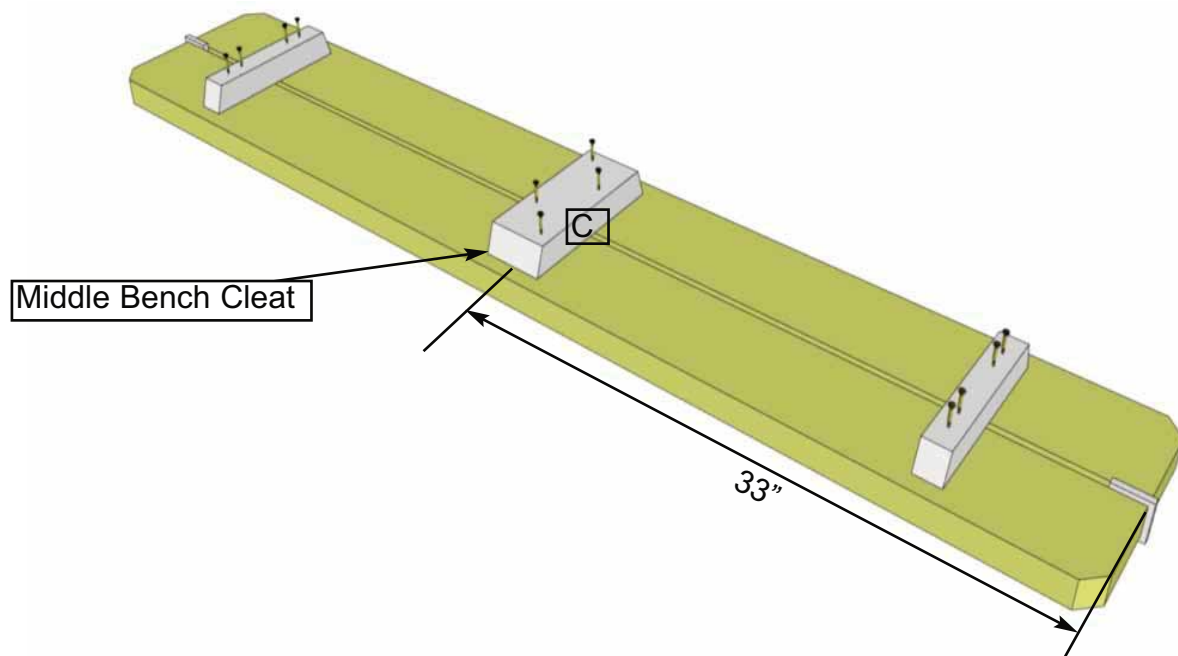

**3.** Complete the 2nd Bench Assembly as per **Step 2**. Measure 33" from end to center point and attach **Middle Bench Cleat (C)** with **4 - 2 1/2" Screws**. Complete attachment of all Cleat Screws. Complete 2nd Bench Assembly as previously described before moving forward.

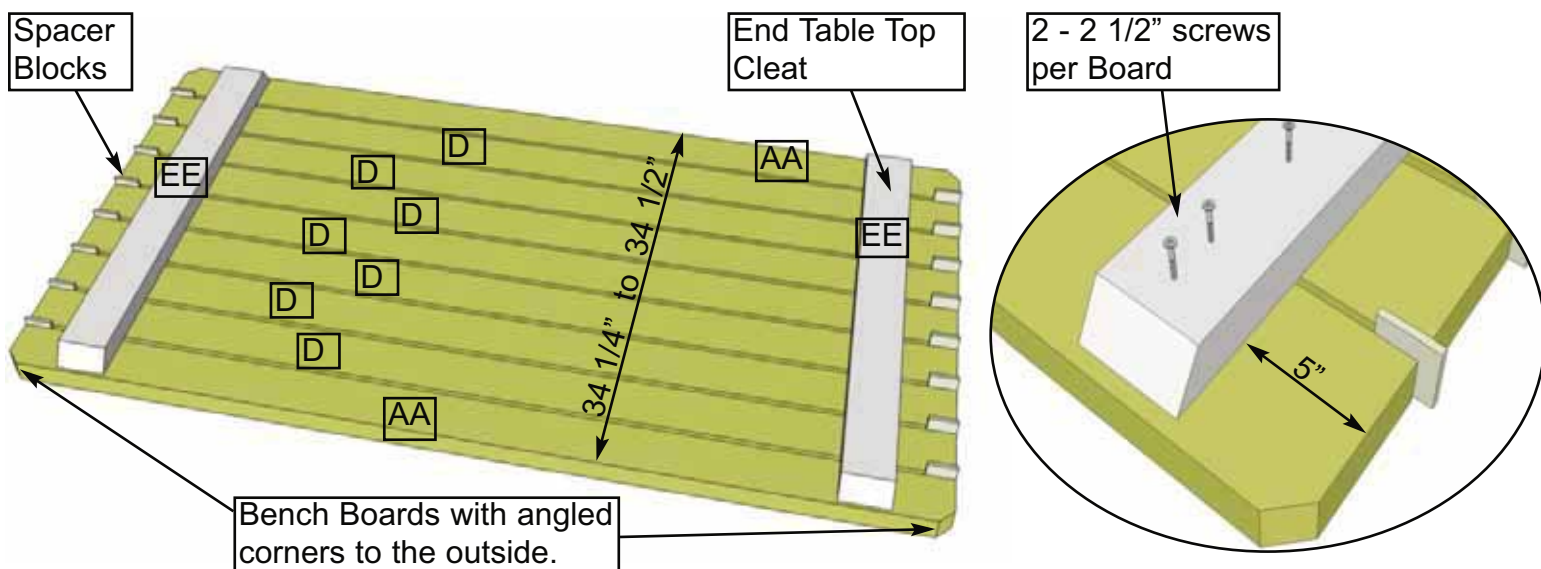

**4.** Lay out 2 **Table Top Outside Boards** and 7 **Table Top Boards** as illustrated above. Use 3/8" thick **Spacer Blocks** to evenly space boards so the total **Table Top Width** is between **34 1/4"** and **34 1/2"**.

Position 2 **End Table Top Cleats** 5" from the ends and secure to Table Top with **2 - 2 1/2" Screws** per board (**18 Screws per cleat**).

Parts	
<b>AA</b>	<b>Table Top Outside Boards</b> (1 1/2" x 3 1/2" x 66") x 2
<b>D</b>	<b>Table Top Boards</b> (1 1/2" x 3 1/2" x 66") x 7
<b>EE</b>	<b>End Table Top Cleats</b> (1 1/2" x 2 1/2" x 33 1/2") x 2
<b>I</b>	<b>Spacer Blocks</b> (3/8" x 2" x 2") x 16
Hardware	
<b>S1</b>	<b>2 1/2" Screws</b> x 36 total



**5.** Locate **Bench Support** and 2 **Legs**. Slide **Carriage Bolts** through pre-drilled holes in each piece. Place **Reinforcement Bracket** on inward face of Bench Support, slip **Washer** on, and tighten **Nut** with 1/2" Wrench to complete. Complete 2 sets of Bench Support / Leg Assemblies.

Parts (Steps 5 - 6)

**F - Bench Supports** (1 1/2" x 3 1/2" x 62 1/2") x 2

**G - Legs** (1 1/2" x 3 1/2" x 33 3/4") x 4

Hardware (Steps 5 - 6)

**BC1 - Carriage Bolt** (5/16") x 8 total

**NU1 - Nut** (5/16") x 8 total

**WA2 - Washer** (5/16") x 8 total

**Y37 - Reinforcement Bracket** (3" x 6") x 4 total

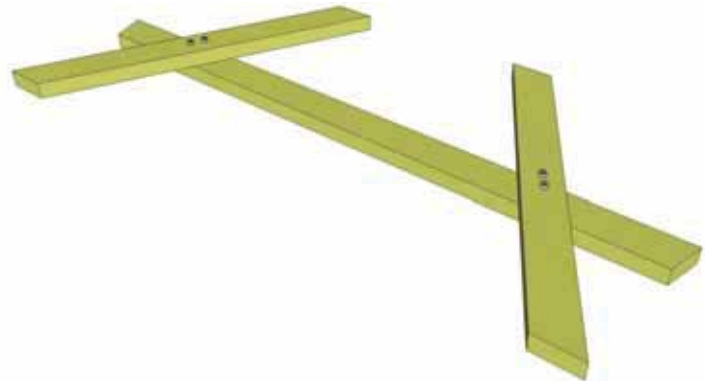
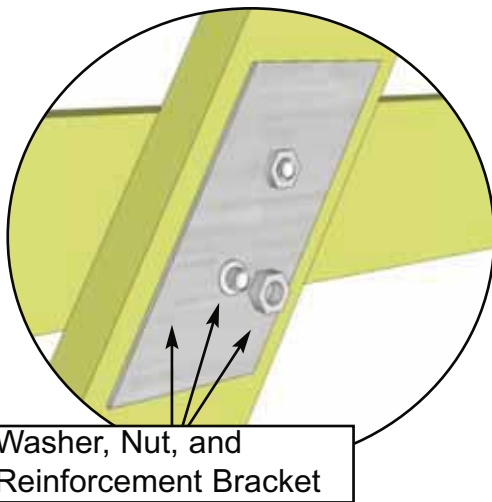
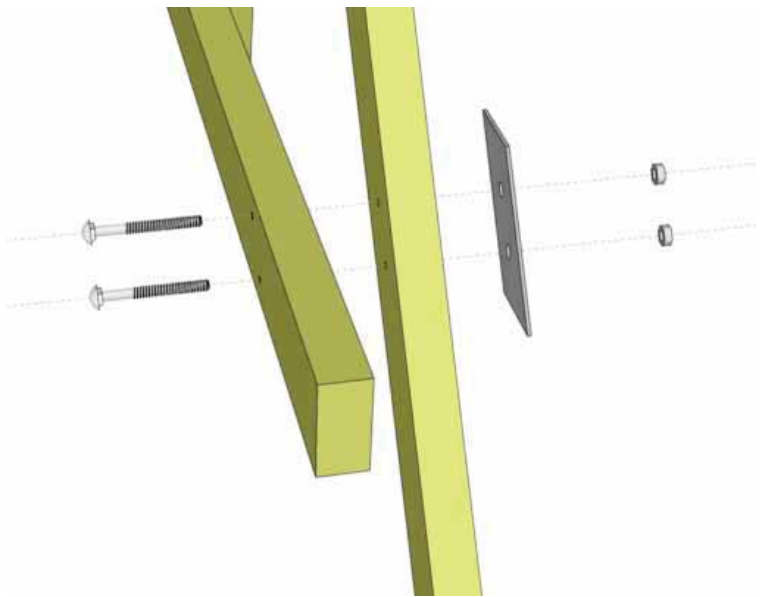
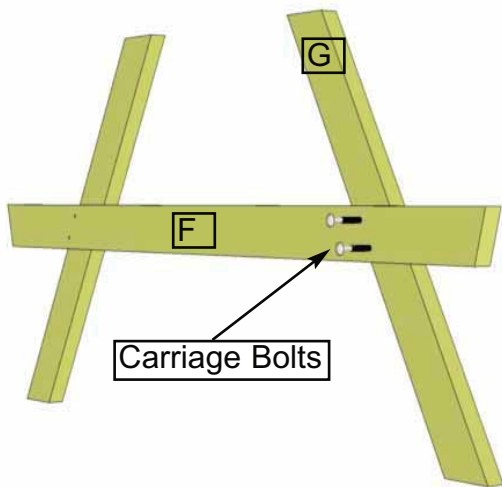

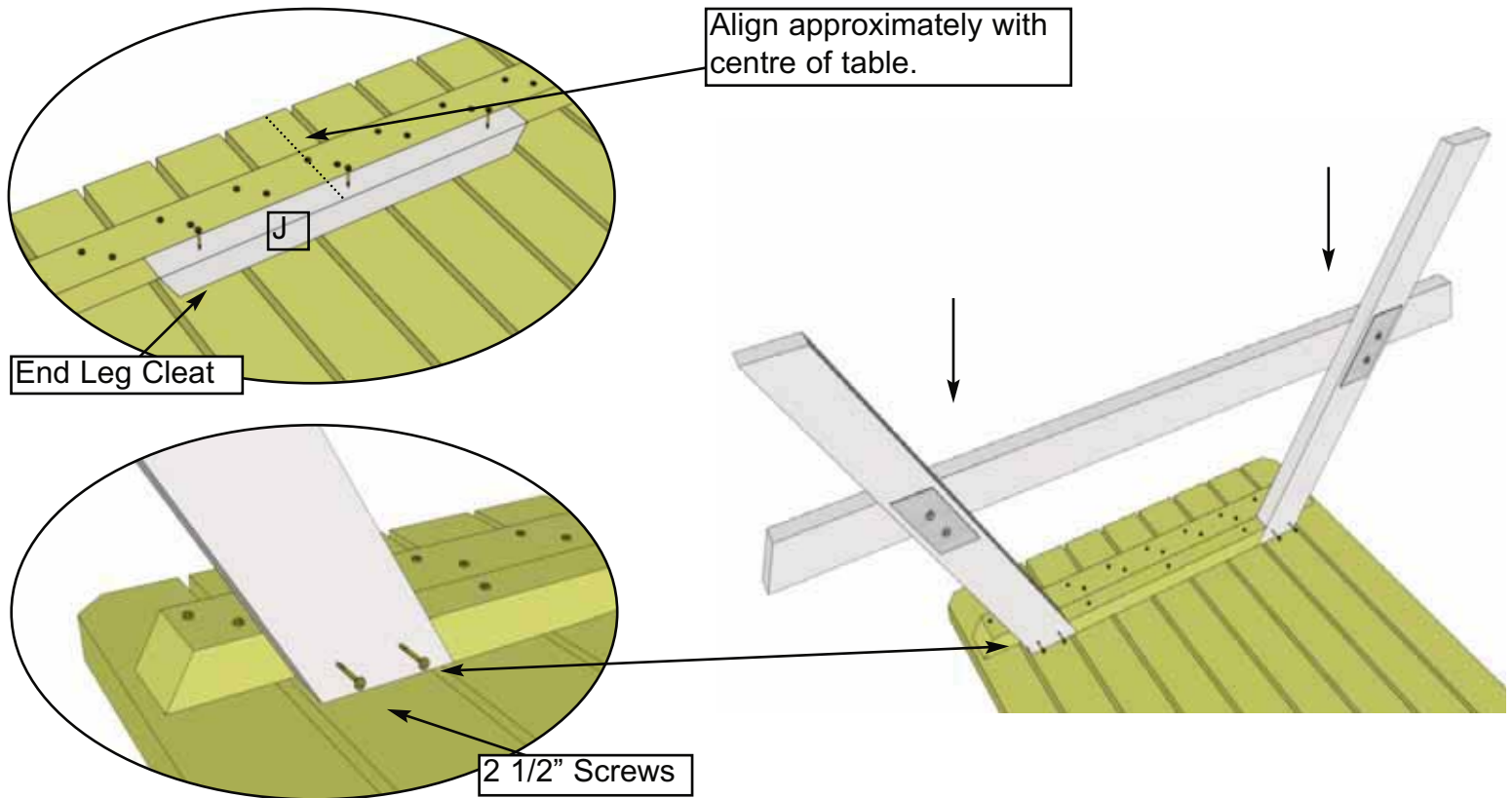

**6.** Locate **End Leg Cleats** and **Legs**. Place End Leg Cleat beside Table Top Cleat, aligned with centre of table, and secure with **3 - 2 1/2" Screws**.

Position Bench Support / Leg Assembly around End Leg Cleat. When in correct position, pilot hole 2 holes with 1/8" Drill Bit and secure with **2 - 2 1/2" Screws** per Leg. Complete this again on other side of table.

<u>Parts (Steps 6 - 7)</u>	
<b>J - End Leg Cleats</b>	(1 1/2" x 1 1/2" x 20") x 2
<b>K - Middle Leg Cleats</b>	(1 1/2" x 1 1/2" x 28") x 2
<u>Hardware (Steps 6 - 7)</u>	
<b>S1 - 2 1/2" Screws</b>	x 24 total

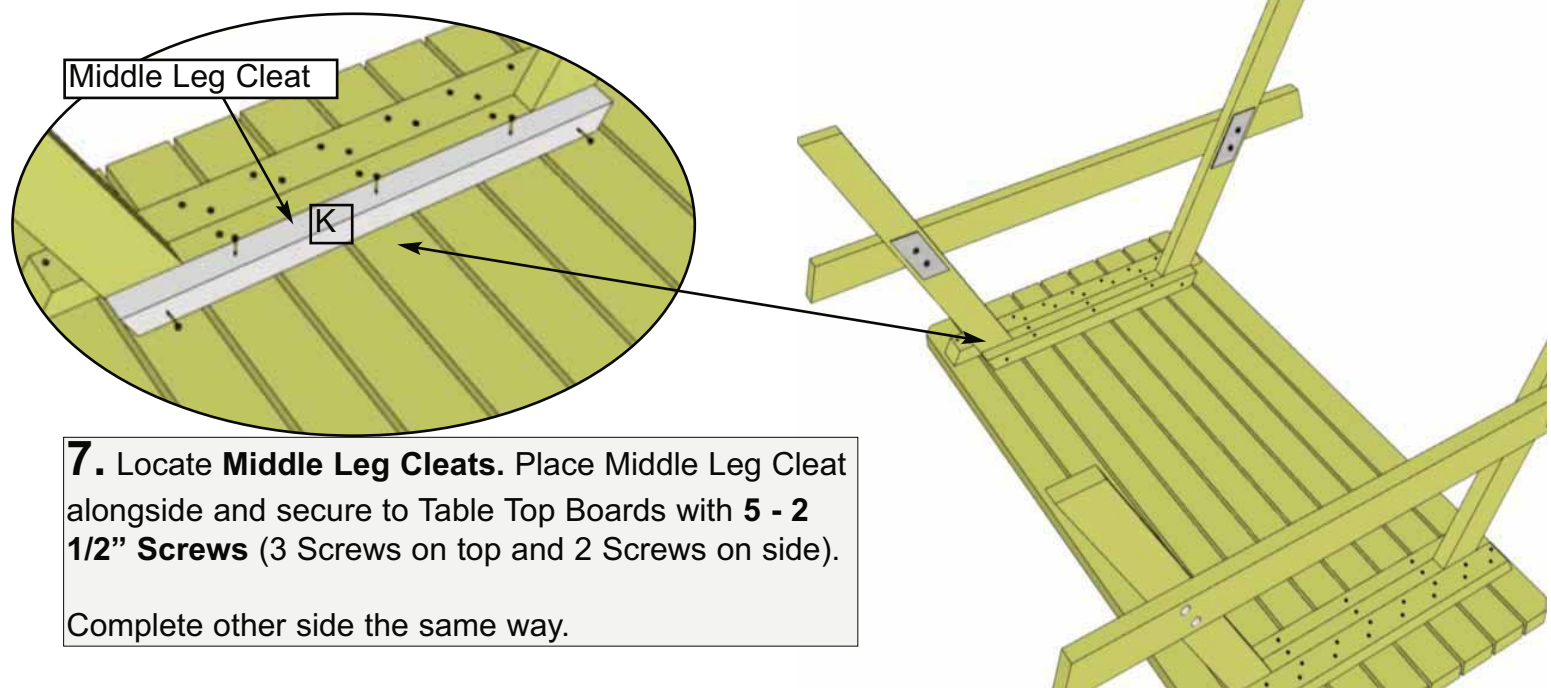

**7.** Locate **Middle Leg Cleats**. Place Middle Leg Cleat alongside and secure to Table Top Boards with **5 - 2 1/2" Screws** (3 Screws on top and 2 Screws on side).  
Complete other side the same way.

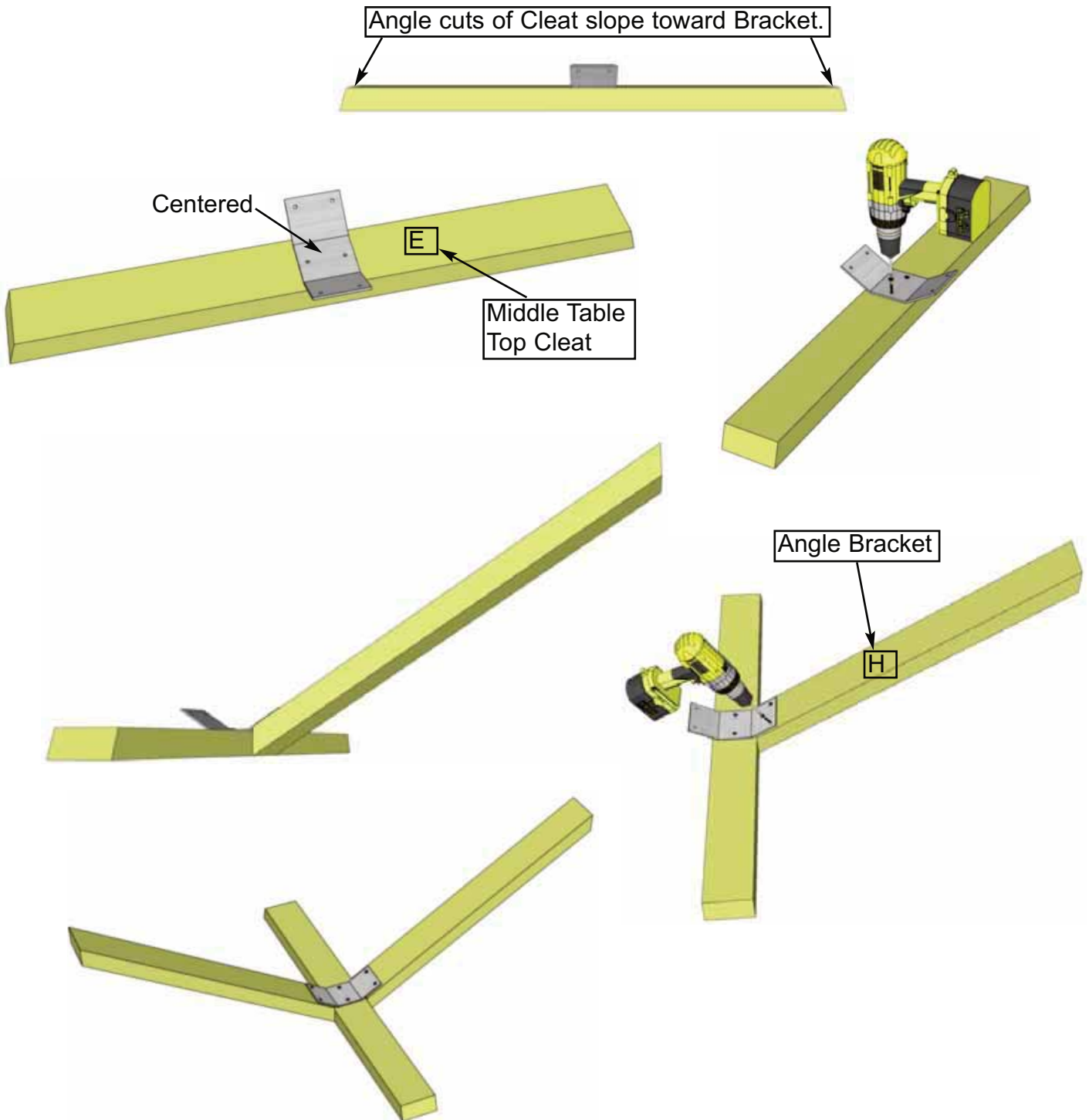

**8.** Center **Middle Reinforcement Bracket** on **Middle Table Top Cleat** as shown and attach with **2 - 1 1/4" Screws**.

Align an **Angle Bracket** onto the side of Middle Table Top Cleat as shown and attach to Middle Reinforcement Bracket with **2 - 1 1/4" Screws**. Attach second **Angle Bracket** on other side the same.

Parts

**E - Middle Table Top Cleat**  
(1 1/2" x 3 1/2" x 33 1/2") x 1

**H - Angle Brackets**  
(1 1/2" x 3 1/2" x 27 7/8") x 2

Hardware

**S2 - 1 1/4" Screws** x 6 total  
**Y38 - Middle Reinforcement Bracket** x 1 total



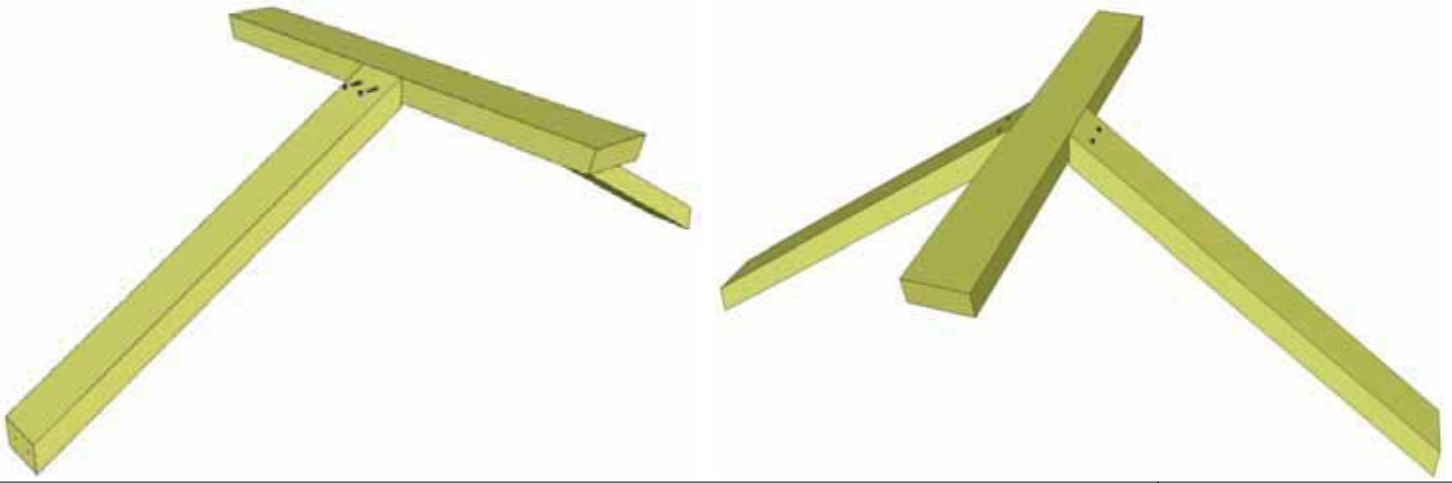

**9.** To further secure the Cleat / Angle Bracket Assembly, attach **2 - 2 1/2" Screws** per side horizontally through the pre-drilled hole on the end of the Angle Bracket and into the Middle Table Top Cleat.

Hardware  
**S1 - 2 1/2" Screws**  
 x 4 total

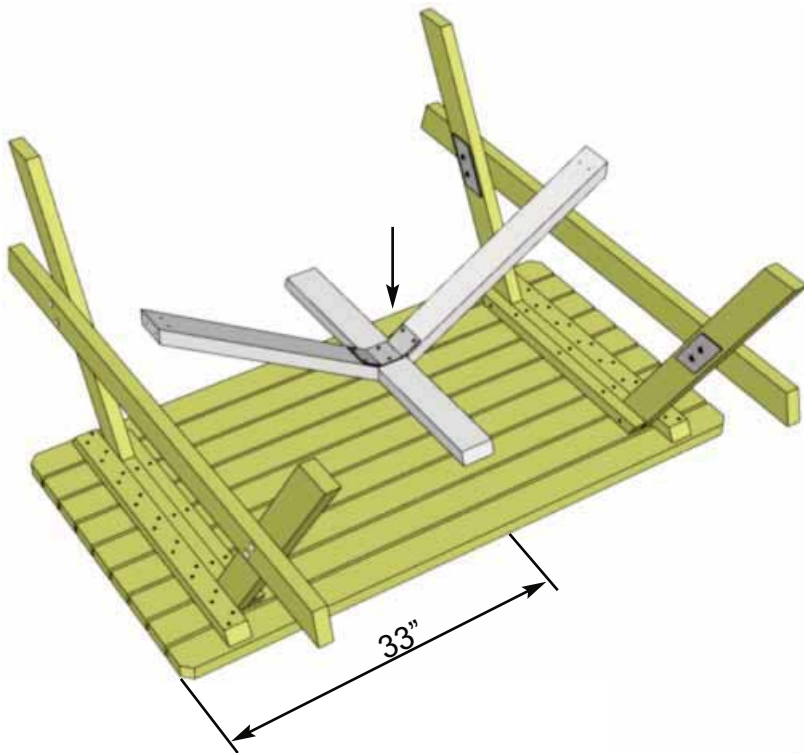

**Important:** Do not attach Angle Brackets until **Step 12.**

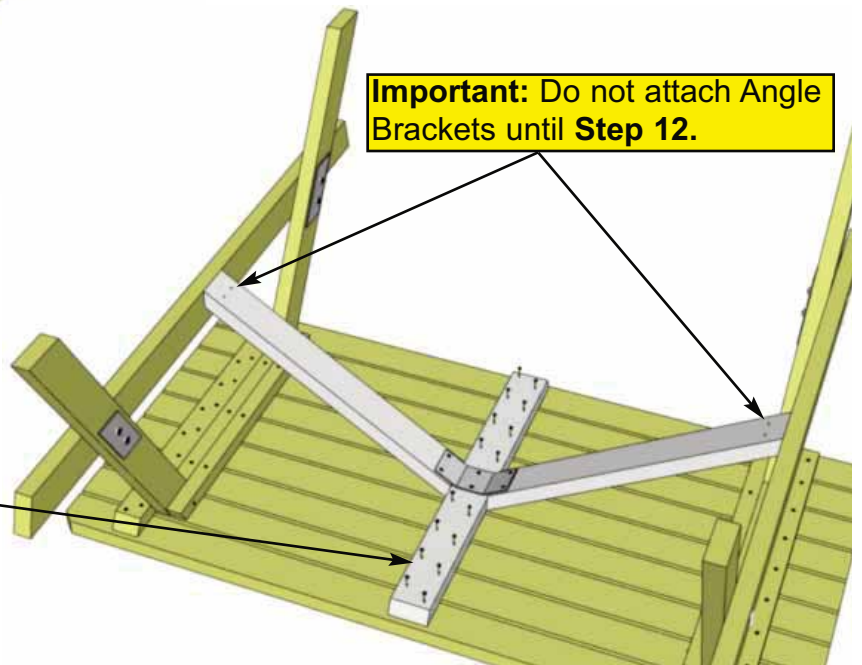
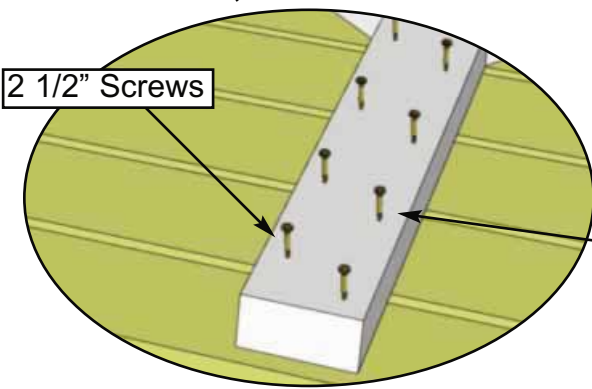

**10.** Flip Cleat / Angle Bracket Assembly over and center on Table Top Boards. The ends of Angle Brackets will sit flush against Bench Supports. Secure Cleat to Table Top Boards with **2 - 2 1/2" Screws** per Board.

Hardware  
**S1 - 2 1/2" Screws**  
 x 16 total

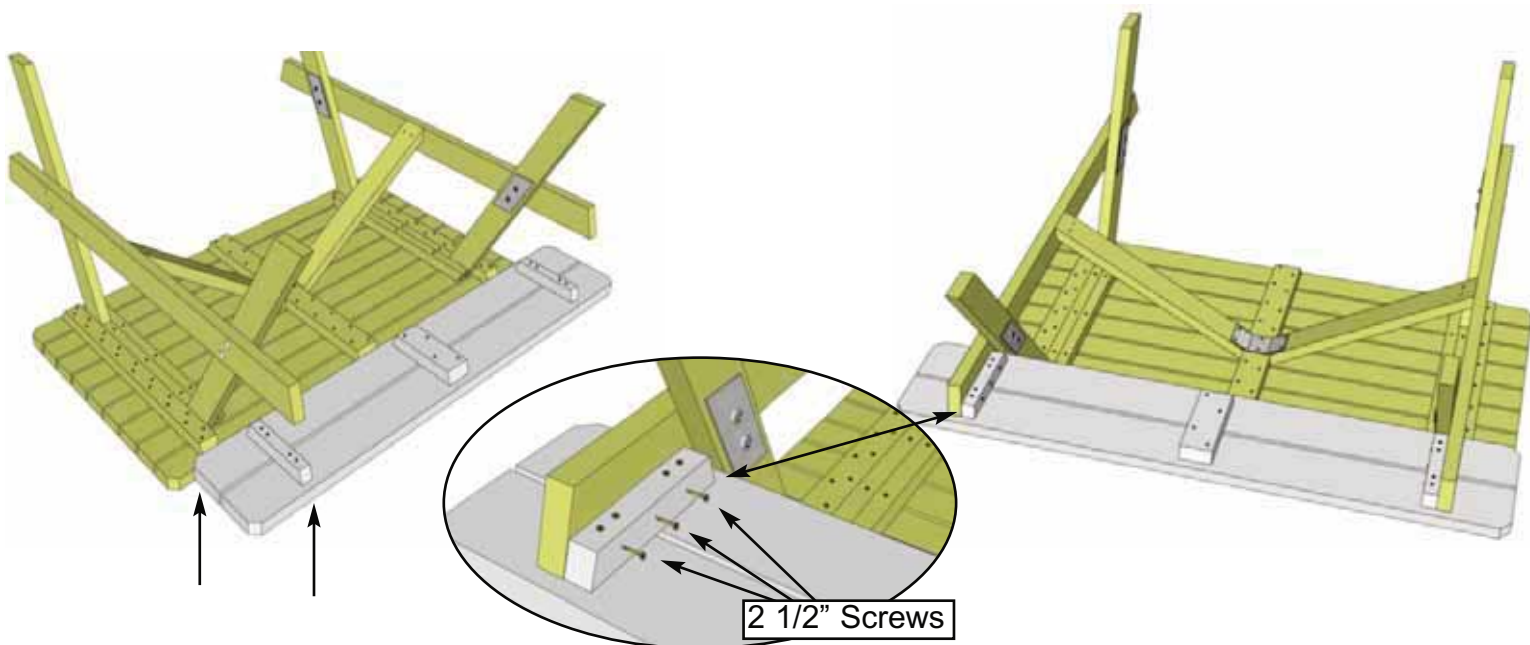

**11.** Lift and position pre-built Benches from **Step 3** onto Bench Supports as shown above. Screw End Bench Cleats into Bench Supports with **3 - 2 1/2" Screws** per side. Drill 1/8" pilot holes first to prevent wood from splitting. Complete attachment of 2nd Bench on opposite side.

Hardware  
**S1 - 2 1/2" Screws**  
 x 12 total

**Hint:** Have a helper assist you to support the Bench while screwing Bench End Cleat into Bench Support.

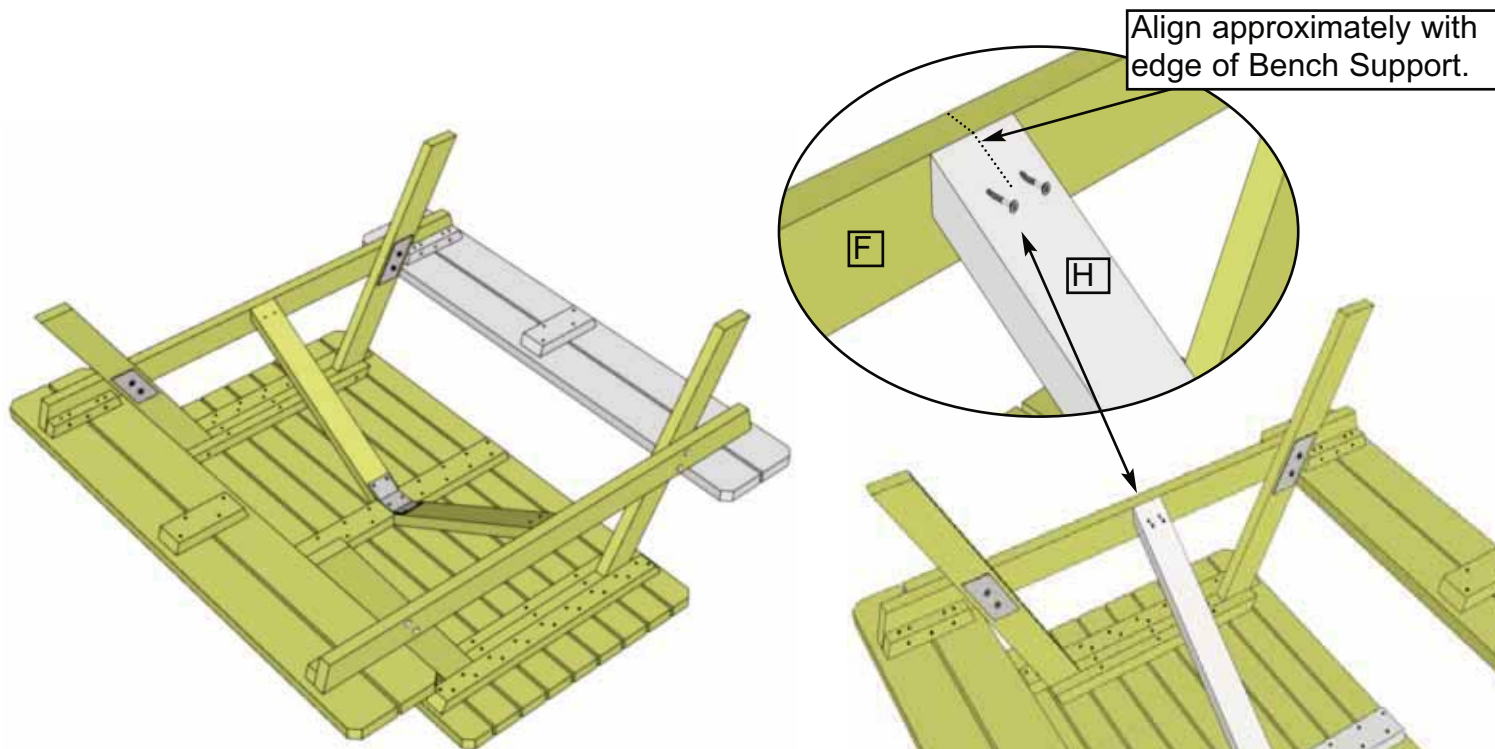

**12.** Attach Angle Brackets (H) to Bench Supports (F) securing each Angle Bracket with **2 - 2 1/2" Screws** into pre-drilled holes located at the end of each piece. Complete both sides.

Hardware  
**S1 - 2 1/2" Screws**  
 x 4 total



**13.** Carefully flip completed Picnic Table over with your helper and place legs on firm level ground. Adjust as required.



## Congratulations on assembling your Cedar Table

**Note;** The Cedar Table is shipped as an unfinished product. If exposed to the elements, the western red cedar lumber will weather to a silvery-gray color. If you plan on treating the wood, we recommend that you consult with a paint and stain dealer in your area for their recommendations.

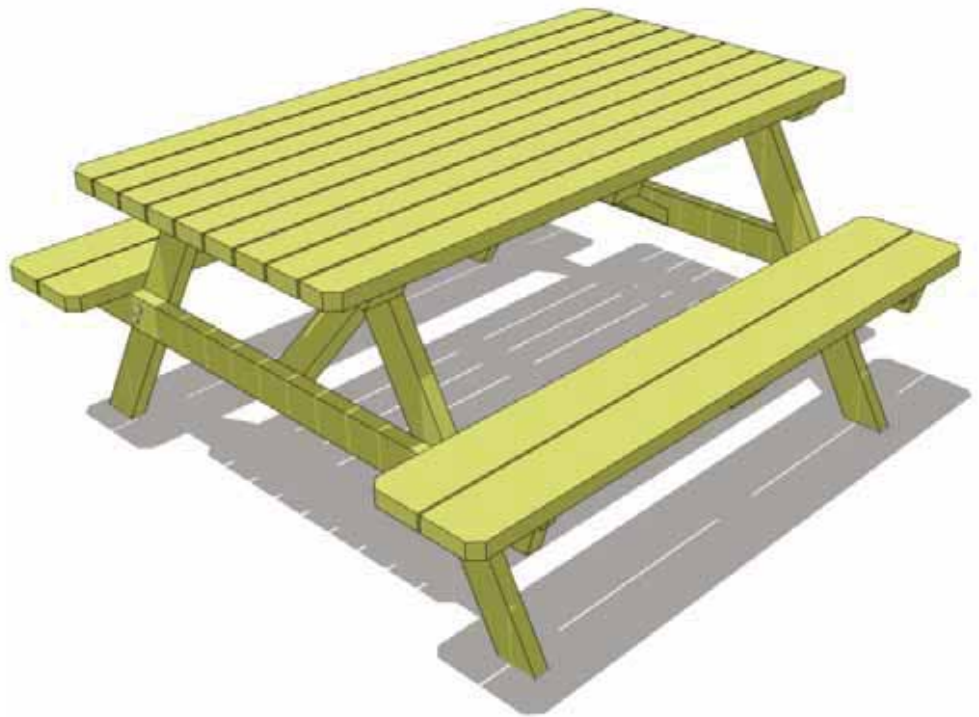

We hope your experience assembling your Cedar Table has been both positive and rewarding.

We value your feedback and would like to hear back from you on how well we are doing in the following areas:

1. **Customer Service**
2. **On Time Shipping**
3. **Motor Freight Delivery**
4. **Quality of Materials**
5. **Assembly Manual**
6. **Overall Satisfaction.**



Please call, write or email us at:

### Outdoor Living Today

Canadian Address  
9393 287th Street  
Maple Ridge, British Columbia  
Canada V2W 1L1

United States Address  
P.O. Box 96  
Sumas, Washington  
USA 98295

The materials contained in this Assembly Manual may be downloaded or copied provided that ALL copies retain the copyright and any other proprietary notices contained on the materials. No material may be modified, edited or taken out of context such that its use creates a false or misleading statement or impression as to the positions, statements or actions.