



ASSEMBLY INSTRUCTIONS

Pour le français, voir la page 2. Para el español, ver la página 3.

11' x 11', 11' x 18.5', or 11' x 21' OUTDOOR SHED

MODELS 60187 / 60236 / 60237

BEFORE ASSEMBLY:

- Assemble on a level platform
- At least 3 people recommended for setup



For Customer Service in mainland Europe and the United Kingdom:
E-mail: cs@lifetimeproducts.eu

TOOLS REQUIRED

7/16" (11 mm) wrench
3/8" (10 mm) wrench

5/16" (8 mm) Wood Drill Bit
5/16" (8 mm) Masonry Drill Bit

TABLE OF CONTENTS

Icon Legend.....	4
Warnings & Notices.....	5
Platform Construction.....	6
Truss Assembly.....	15
Gable Assembly.....	19
Door Assembly.....	21
Domed Skylight Assembly.....	38
Floor Assembly.....	43
Wall Assembly.....	47
Truss Installation.....	53
Parts Identifier.....	57
Shelving Installation.....	69
Door Frame Installation.....	71
Trim Installation.....	85
Gable Installation.....	89
Roof Assembly.....	91
Window Installation.....	101
Pegboard Strip Installation.....	109
Shed Alignment.....	111
Shed Anchoring.....	114
Cleaning & Care.....	119
Registration.....	120
Warranty.....	121

QUESTIONS? CONTACT LIFETIME CUSTOMER SERVICE:

Call: **1-800-225-3865**
7:00 am–5:00 pm (Monday–Friday) MST
and 9:00 am–1:00 pm Saturday MST

Live Chat: www.lifetime.com
(click on "LIVE CHAT" tab)

Video Instructions: www.youtube.com/lifetimeproducts

MODEL# AND PRODUCT ID (both are needed when contacting us)
Model Number: **60187 / 60236 / 60237**
Product ID:



INSTRUCTIONS D'ASSEMBLAGE

For English, see page 1. Para el español, ver la página 3.

ABRI EXTÉRIEUR DE 3,35 x 3,35 m, 3,35 x 5,63 m ou 3,35 x 6,4 m

MODÈLES n° 60187 / 60236 / 60237

AVANT L'ASSEMBLAGE :

- Assembler sur une plate-forme nivelée
- Nous recommandons, au moins, 3 adultes pour l'assemblage



Pour nos services à la clientèle du continent européen et au Royaume-Uni :
É-mail : cs@lifetimeproducts.eu

OUTILS REQUIS

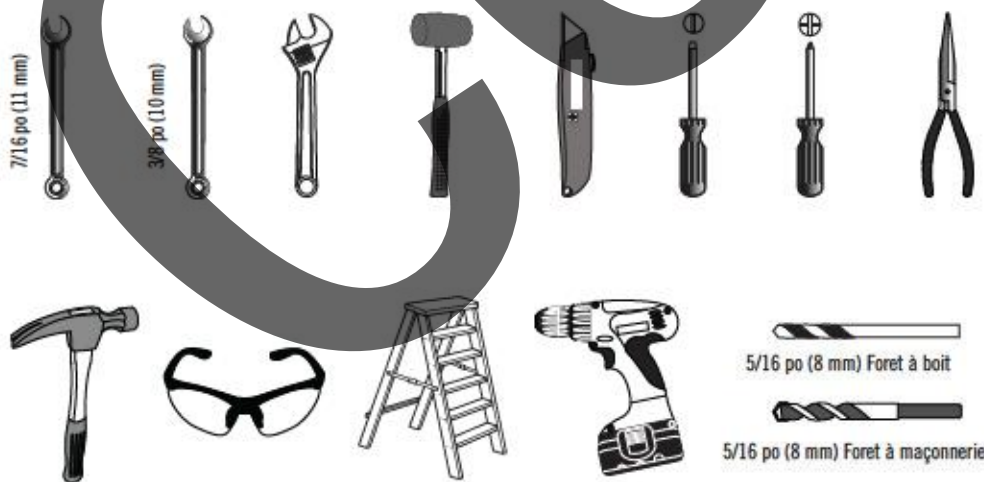

SOMMAIRE

Légende des icônes.....	4
Avertissements et avis.....	5
Assemblage de la plate-forme.....	6
Assemblage des fermes.....	15
Assemblage des pignons.....	19
Assemblage des portes.....	21
Assemblage des lucarnes.....	38
Assemblage du plancher.....	43
Assemblage des murs.....	47
Installation des fermes.....	53
Identificateur de pièces.....	57
Installation du rayonnage.....	69
Installation des portes.....	71
Installation des moulures.....	85
Installation des pignons.....	89
Assemblage du toit.....	91
Installation des carreaux.....	101
Installation des organisateurs.....	109
Alignement des portes.....	111
L'ancrage de l'abri.....	114
Nettoyage et entretien.....	119
Enregistrement.....	120
Garantie.....	122

QUESTIONS ?

CONTACTER AUX SERVICES À LA CLIENTÈLE LIFETIME® :

Composer le **1-800-225-3865**
Du lundi au vendredi 7:00 hr – 17:00 hr (HNR)
et samedi 9:00 hr – 13:00 hr (HNR)

Entretien en direct: www.lifetime.com
(cliquer sur la languette « LIVE CHAT »)
Vidéos éducatifs: www.youtube.com/lifetimeproducts

N° DE MODÈLE ET RÉFÉRENCE DU PRODUIT (il faut avoir les deux au moment de nous contacter)
N° de modèle : 60187 / 60236 / 60237
Référence du produit :



INSTRUCCIONES DE ENSAMBLE

For English, see page 1. Pour le français, voir la page 2.

CASETA EXTERIOR DE 3,35 x 3,35 m, 3,35 x 5,63 m o 3,35 x 6,4 m

MODELOS n° 60187 / 60236 / 60237

ANTES DEL ENSAMBLE:

- Ensamblar sobre una plataforma nivelada
- Recomendamos, por lo menos, 3 adultos para el ensamble



Para nuestros servicios a clientes en el continente europeo y el Reino Unido:
Correo electrónico: cs@lifetimeproducts.eu

INSTRUMENTAL REQUERIDO



ÍNDICE

Leyenda de iconos.....	4
Advertencias y avisos.....	5
Ensamble de la plataforma.....	6
Ensamble de las cerchas.....	15
Ensamble de las fachadas.....	19
Ensamble de las puertas.....	21
Ensamble de los tragaluces.....	38
Ensamble del piso.....	43
Ensamble de los muros.....	47
Instalación de las cerchas.....	53
Identificador de piezas.....	57
Instalación de la estantería.....	69
Instalación de las puertas.....	71
Instalación de las molduras.....	85
Instalación de las fachadas.....	89
Ensamble del tejado.....	91
Instalación de las hojas de ventana.....	101
Instalación de los organizadores.....	109
Alineación de las puertas.....	111
Anclaje de la caseta.....	114
Limpieza y cuidado.....	119
Registro.....	120
Garantía.....	123

¿PREGUNTAS?

PONERSE EN CONTACTO CON LOS SERVICIOS DE CLIENTES LIFETIME®:

Marcar : 1-800-225-3865
De lunes hasta viernes 7:00 h–17:00 h (MST)
y sábado 9:00 h–13:00 h (MST)

Chat en vivo: www.lifetime.com
(clicar en la lengüeta «LIVE CHAT»)
Instrucciones en vídeo: www.youtube.com/lifetimeproducts

MODEL E ID DEL PRODUCTO (se necesitan los dos al contactarnos)
Número de modelo: 60187 / 60236 / 60237
ID del producto:



ICON LEGEND / LÉGENDE DES ICÔNES / LEYENDA DE ÍCONOS



- Indicates special heed should be taken when reading.
- Indique qu'une attention spéciale doit être portée à la lecture.
- Indica que uno debe prestar atención al leer.



- Indicates the parts to be used for a section.
- Indique les pièces à utiliser pour une section.
- Indica las piezas que se usarán en una sección.



- Indicates no parts required for a specific section.
- Indique qu'aucune pièce n'est requise pour une section précise.
- Indica que no se necesitan partes en una sección específica.



- Indicates the hardware to be used for a section.
- Indique la quincaillerie à utiliser pour une section.
- Indica el herraje que se usará en una sección.



- Indicates no hardware required for a specific page.
- Indique qu'aucun matériel n'est requis pour une page précise.
- Indica que no se necesita herraje en una página específica.



- Indicates the tools to be used for a section.
- Indique les outils à utiliser pour une section.
- Indica el instrumental que se usará en una sección.



- Indicates to use/not to use an electric drill for a specific step.
- Indique quand utiliser ou ne pas utiliser une perceuse électrique pour une étape précise.
- Indica usar o no usar un taladro eléctrico en un paso específico.



- These nuts are centerlock nuts. They are designed to be tight; therefore, they will be harder to tighten. Tighten until flush with the metal or plastic.
- Ces écrous sont des écrous de blocage central. Ils sont conçus pour être serrés; de ce fait, ils seront plus difficiles à resserrer. Serrer jusqu'à ce qu'ils soient au ras du métal ou du plastique.
- Estas tuercas son tuercas de bloqueo central. Ellas son diseñadas para ser apretadas; entonces, ellas serán más difícil



READ CAREFULLY / VEILLER LIRE ATTENTIVEMENT / LEER EL SIGUIENTE CUIDADOSAMENTE

• English:

These instructions cover three different sized sheds. You purchased model 60187, 60236, or 60237:

Model 60187 is the 11' x 11' (3,35 x 3,35 m) shed with three doors.

Model 60236 (11' x 18,5' shed) is model 60187 plus one kit 0125 containing one 30" extension and one kit 6426 containing two 30" extensions with two windows (three total extensions).

Model 60237 (11' x 21' shed) is model 60187 plus two kits 6426 containing two 30" extensions with two windows (four total extensions).

• Français :

Ces instructions traitent trois abris de longueurs différents. Vous avez acheté le modèle 60187, 60236, ou 60237:

Le modèle 60187 est un abri de 3,35 x 3,35 m avec trois portes.

Le modèle 60236 (3,35 x 5,64 m) est le modèle 60187 et un kit 0125 qui contient une extension de 76,2 cm (30") et un kit 6426 qui contient deux extensions de 76,2 cm (30") avec deux fenêtres dans chaque le kit (trois kits au total).

Le modèle 60237 (3,35 x 6,4 m) est le modèle 60187 et deux kits 6426 kits qui contiennent deux extensions de 76,2 cm (30") et deux fenêtres dans chaque kit (quatre extensions au total).

• Español:

Estas instrucciones cubren tres casetas de diferentes largos. Usted ha comprado el modelo 60187, 60236, o 60237:

El modelo 60187 es una caseta de 3,35 x 3,35 m y viene con tres puertas.

El modelo 60236 (3,35 x 6,4 m) es el modelo 60187 más un kit 0125 que contiene una ampliación de 76,2 cm y un kit 6426 que contiene dos ampliaciones de 76,2 cm (30") y dos ventanas (tres ampliaciones en total).

El modelo 60237 (3,35 x 6,4 m) es el modelo 60187 más dos kits 6426 que contienen dos ampliaciones de 76,2 cm (30") y dos ventanas en cada kit (cuatro ampliaciones en total).



WARNINGS & NOTICES / AVERTISSEMENTS ET AVIS / ADVERTENCIAS Y AVISOS

English:

- **Failure to follow these warnings may result in serious injury or property damage and will void warranty.**
- To ensure safety, do not attempt to assemble this product without following the instructions carefully.
- Consult all local building codes to verify if the shed requires a building permit.
- Verify the foundation is completely level before assembling the shed.
- Be aware that plastic pieces can be damaged by overtightening the screws. To avoid damage, we strongly recommend the use of a drill with a low torque setting. A #2 Phillips screwdriver may also be used.
- Three capable adults are required for assembly.
- All who participate in the assembly process should wear safety glasses throughout the assembly.
- If using a ladder during assembly, use extreme caution.
- In heavy snowfall areas, we recommend removing snow from the roof.
- Do not use or store hot objects near the product.
- Proper and complete assembly are essential to reduce the risk of accident or injury.
- We strongly recommend anchoring your shed when it is finished. The last section, Shed Anchoring, in this manual, shows the hardware you will need to complete the anchoring. You can find the hardware at your local hardware store.
- **Most injuries are caused by misuse and/or not following instructions. Use caution when using this product.**

Français :

- **Ne pas suivre ces avertissements peut entraîner des blessures graves ou des dommages à la propriété et annulera la garantie.**
- Afin d'assurer la sécurité, ne pas tenter d'assembler ce produit sans suivre attentivement les instructions.
- Consulter tous les codes du bâtiment afin de vérifier si l'abri nécessite un permis de construire.
- Vérifier que la fondation est complètement à niveau avant l'assemblage de l'abri.
- Ne pas oublier que les pièces de plastique peuvent être endommagées en serrant trop les vis. Afin d'éviter les dommages, nous recommandons fortement l'utilisation d'une perceuse à faible couple. Un tournevis cruciforme n° 2 peut aussi être utilisé.
- Trois adultes en bonne condition physique sont nécessaires pour l'assemblage.
- Tout ceux qui participent au processus de l'assemblage doivent porter des lunettes de sécurité tout au long de l'assemblage.
- Si une échelle est utilisée pour l'assemblage, il faut être extrêmement prudent.
- Dans les zones de fortes tombées de neige, il est recommandé de dégager le toit.
- Ne pas utiliser ou entreposer des objets très chauds près de ce produit.
- Un bon assemblage complet est nécessaire pour réduire le risque d'accident ou de blessure.
- Il est fortement recommandé d'ancrer l'abri lorsque l'assemblage est terminé. La dernière section, Ancrage de l'abri, de ce manuel, indique les matériaux nécessaires pour l'ancrage. Les matériaux se trouvent dans la quincaillerie locale.
- **La majorité des blessures sont causées par une mauvaise utilisation et/ou le non suivi des instructions. Soyez prudent lorsque vous utilisez ce produit.**

Español:

- **No seguir estas advertencias puede resultar en lesiones graves o daños a la propiedad y anulará la garantía.**
- A fin de garantizar la seguridad, no intentar ensamblar este producto sin seguir cuidadosamente las instrucciones.
- Consultar todos los códigos de construcción locales para verificar si la caseta requiere un permiso de construcción.
- Verificar que el concreto esté nivelado completamente antes de ensamblar la caseta.
- Tener en cuenta que las piezas de plástico pueden dañarse si los tornillos se aprietan de más. A fin de evitar daños, lo exhortamos a que use un taladro con función de torque bajo. También puede usarse un desatornillador Phillips no. 2.
- Se necesitan tres adultos para el ensamble.
- Todos los que participen en el proceso de ensamble debe usar anteojos de seguridad durante todo el ensamble.
- Si se usa una escalera durante el ensamblado, es preciso tener cuidado.
- En áreas de nevadas fuertes, recomendamos retirar la nieve del techo.
- No usar ni guardar objetos calientes cerca del producto.
- El ensamble correcto y completo son esenciales para reducir el riesgo de accidente o lesión.
- Lo exhortamos a anclar la caseta al terminar el ensamble. La última sección, Anclaje de la caseta, en este manual muestra el herraje necesaria para terminar el anclaje. Se encuentra el herraje en la ferretería local.
- **La mayoría de las lesiones suceden a causa del mal uso y/o por no seguir las instrucciones. Tener precaución al usar este producto.**

PLATFORM CONSTRUCTION / CONSTRUCTION DE LA PLATE-FORME / CONSTRUCCIÓN DE LA PLATAFORMA



• You must provide a platform on which to assemble your 11', 18.5', or 21' shed. Proper building permit documentation may be required in your neighborhood. Consult all local building codes prior to assembling the shed. Before beginning assembly, you must pour or construct a platform. There are two types:

- Concrete
- Wood Frame

Select the type, but know the surface must be leveled and flat before installation. If the surface is not properly leveled and flat, the shed will not assemble correctly. Proper surface leveling will save you time in the long run, so please do not ignore this step. **We recommend a Concrete platform. It will be the most durable and long-lasting choice. The platform you choose must be built above ground in order to avoid water pooling inside the shed. All lumber must be rated for outdoor use!**



• Il faut construire une plate-forme sur laquelle vous devez assembler votre abri de 3,35, 5,64, ou 6,4 m. Il est possible que le quartier exige une documentation visant les permis de construire. Consulter tous les codes du bâtiment locaux, ainsi que les décrets des villes et comtés, pour vérifier que la construction de l'abri extérieur n'exige pas un permis de construire. Avant de commencer l'assemblage, il faut couler ou construire une plate-forme. Il y a deux styles :

- Béton
- Cadre à bois

Sélectionner le style, mais il faut savoir que la surface d'installation doit être de niveau et plate. Si la surface n'est pas correctement de niveau et plate, l'assemblage de l'abri ne se fera pas correctement. On gagnera du temps sur le long terme grâce à une surface bien de niveau, on ne doit donc pas négliger cette étape. **Nous recommandons une plate-forme en béton. Ce choix sera le plus durable. La plate-forme que vous choisissez doit être construite au-dessus du sol afin d'éviter l'accumulation d'eau à l'intérieur de l'abri. Tous le bois d'oeuvre doit être approuvé pour l'usage à l'extérieur!**



• Es preciso construir una plataforma sobre la cual usted debe ensamblar su caseta de 3,35, 5,64, o 6,4. Puede suceder que en su vecindario se requiera la documentación apropiada de un permiso de construcción. Consultar todos los códigos locales de construcción y los reglamentos de la ciudad y el municipio para asegurarse de que la construcción de la caseta no requiere un permiso de construcción. Antes de comenzar el ensamble, es necesario verter o construir una plataforma. Hay dos clases:

- Concreto
- Armazón de madera

Seleccione la clase, mas sepa que la superficie debe estar nivelada y plana antes de comenzar el ensamble. Si la superficie no está nivelada y plana de manera adecuada, la caseta no podrá ensamblarse correctamente. La nivelación de la superficie le ahorrará tiempo de trabajo, por lo tanto, le pedimos que no ignore este paso. **Recomendamos una plataforma hecho de concreto. Será la elección más perdurable. La plataforma debe ser construida arriba del suelo para evitar el aflujo de agua dentro de la caseta. ¡Toda la madera debe estar clasificada para el uso externo!**



► SECTION 1 (CONTINUED) / SECTION 1 (SUITE) / SECCIÓN 1 (CONTINUACIÓN)

CONCRETE REQUIRED / BÉTON REQUIS / CONCRETO REQUERIDO



1.3 yd³ (0,99 m³)

1.1

CONCRETE PLATFORM / PLATE-FORME EN BÉTON / PLATAFORMA DE CONCRETO

- The concrete should be approximately 4" (10,2 cm) thick.

The actual dimensions of the 11' x 11' shed, at its widest and longest points, are 132" x 132" (3,35 m x 3,35 m).
The actual dimensions of the 11' x 18.5' shed, at its widest and longest points, are 132" x 222" (3,35 m x 5,64 m).
The actual dimensions of the 11' x 21' shed, at its widest and longest points, are 132" x 252" (3,35 m x 6,4 m).
Ensure you select a site that will accommodate these measurements. **The floor dimensions are a bit smaller than those of the roof; therefore, you will need to build a level surface of:**

11' x 11'—123 1/2" x 123 1/2" (3,14 m x 3,14 m).

11' x 18.5'—123 1/2" x 214 1/4" (3,14 m x 5,44 m).

11' x 21'—123 1/2" x 244" (3,14 m x 6,2 m).

- Le béton doit être une épaisseur de 10,2 cm (4 po).

Les dimensions réelles de votre abri, aux points les plus large et long, sont 3,35 m x 3,35 m (132 po x 132 po).

Les dimensions réelles de votre abri, aux points les plus large et long, sont 3,35 m x 5,64 m (132 po x 222 po).

Les dimensions réelles de votre abri, aux points les plus large et long, sont 3,35 m x 6,4 m (132 po x 252 po).

Veillez à sélectionner un site qui accommodera ces dimensions. **Les dimensions du plancher de votre abri sont plus petites que le toit; ensuite, il faut créer une surface nivelée de:**

11 x 11 pi — 3,14 m x 3,14 m (123 1/2 po x 123 1/2 po).

11 x 18.5 pi — 3,14 m x 5,44 m (123 1/2 po x 214 1/4 po).

11 x 21 pi — 3,14 m x 6,2 m (123 1/2 po x 244 po).

- El concreto debe tener, por lo menos, 10,2 cm (4 in.) de espesor.

Las dimensiones reales de la caseta, a sus puntos más ancho y largo, son 3,35 m x 3,35 m (132 in. x 132 in.).

Las dimensiones reales de la caseta, a sus puntos más ancho y largo, son 3,35 m x 5,64 m (132 in. x 222 in.).

Las dimensiones reales de la caseta, a sus puntos más ancho y largo, son 3,35 m x 6,4 m (132 in. x 252 in.).

Asegurarse de seleccionar un sitio que acomodará estas medidas. **Las dimensiones del piso de la caseta son más pequeñas que el tejado; entonces, necesitará crear una superficie nivelada de:**

11 x 11 ft—3,14 m x 3,14 m (123 1/2 in. x 123 1/2 in.).

11 x 18.5 ft—3,14 m x 5,44 m (123 1/2 in. x 214 1/4 in.).

11 x 21 ft—3,14 m x 6,2 m (123 1/2 in. x 244 in.).

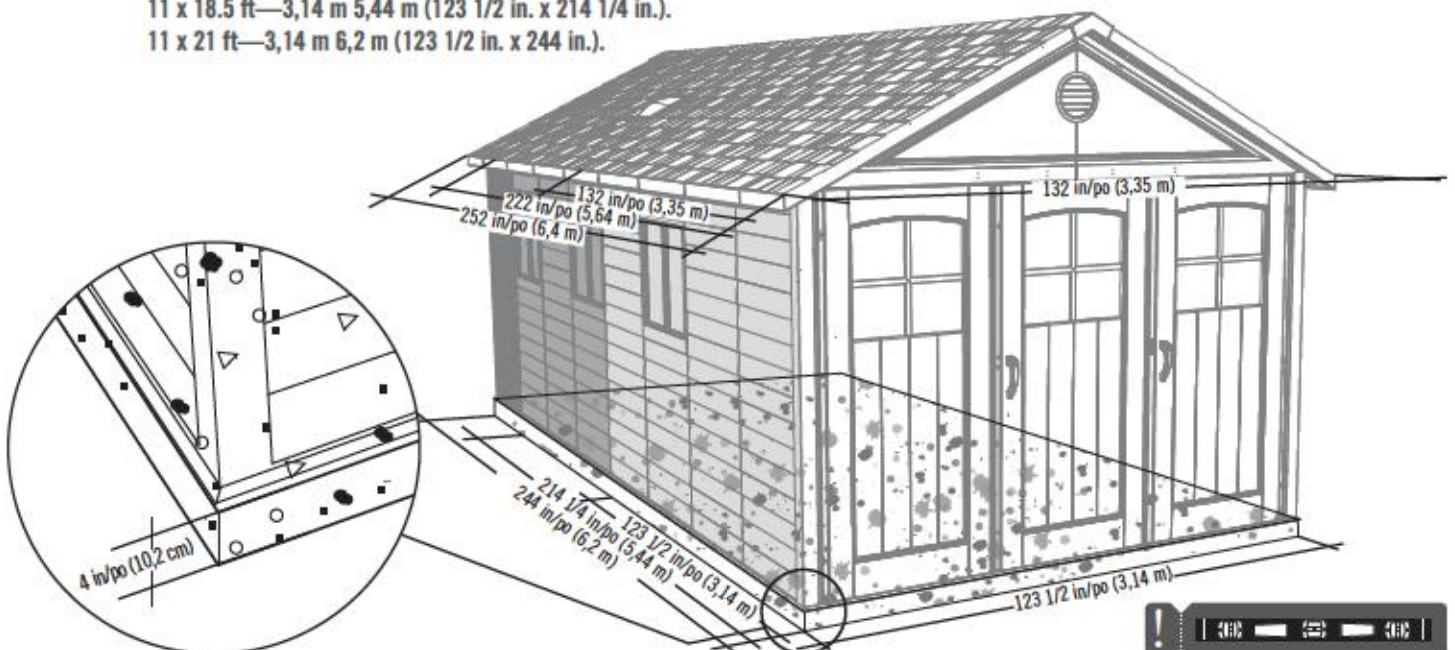

► SECTION 1 (CONTINUED) / SECTION 1 (SUITE) / SECCIÓN 1 (CONTINUACIÓN)

WOOD REQUIRED / BOIS REQUIS / MADERA REQUERIDA



1.2

WOOD PLATFORM / PLATE-FORME EN BOIS / PLATAFORMA DE MADERA

- All lumber must be rated for outdoor use!

The actual dimensions of shed model 60187, at its widest and longest points, are 132" x 132" (3,35 m x 3,35 m).
The actual dimensions of shed model 60236, at its widest and longest points, are 132" x 222" (3,35 m x 5,64 m).
The actual dimensions of shed model 60237, at its widest and longest points, are 132" x 252" (3,35 m x 6,4 m).
Ensure you select a site that will accommodate these measurements. **The floor dimensions are a bit smaller than those of the roof; therefore, you will need to build a level surface of:**

60187: 11' x 11'—123 1/2" x 123 1/2" (3,14 m x 3,14 m). If your shed has these dimensions, see pages 4–5.

60236: 11' x 18.5'—123 1/2" x 214 1/4" (3,14 m x 5,44 m). If your shed has these dimensions, see pages 6–7.

60237: 11' x 21'—123 1/2" x 244" (3,14 m x 6,2 m). If your shed has these dimensions, see pages 8–9.

- Tous le bois d'oeuvre doit être approuvé pour l'usage à l'extérieur!

Les dimensions réelles du modèle 60187, aux points les plus large et long, sont 3,35 m x 3,35 m (132 po x 132 po).
Les dimensions réelles du modèle 60236, aux points les plus large et long, sont 3,35 m x 5,64 m (132 po x 222 po).
Les dimensions réelles du modèle 60237, aux points les plus large et long, sont 3,35 m x 6,4 m (132 po x 252 po).
Veiller à sélectionner un site qui accommodera ces dimensions. **Les dimensions du plancher de votre abri sont plus petites que le toit; ensuite, il faut créer une surface nivelée de:**

60187 : 11 x 11 pi — 3,14 m x 3,14 m (123 1/2 po x 123 1/2 po). Pour un abri avec ces dimensions, voir les page 4 – 5.

60236 : 11 x 18.5 pi — 3,14 m x 5,44 m (123 1/2 po x 214 1/4 po). Pour un abri avec ces dimensions, voir les pages 6 – 7.

60237 : 11 x 21 pi — 3,14 m x 6,2 m (123 1/2 po x 244 po). Pour un abri avec ces dimensions, voir les pages 8 – 9.

- ¡Toda la madera debe estar clasificada para el uso externo!

Las dimensiones reales del modelo 60187, a sus puntos más ancho y largo, son 3,35 m x 3,35 m (132 in. x 132 in.).
Las dimensiones reales del modelo 60236, a sus puntos más ancho y largo, son 3,35 m x 5,64 m (132 in. x 222 in.).
Las dimensiones reales del modelo 60237, a sus puntos más ancho y largo, son 3,35 m x 6,4 m (132 in. x 252 in.).
Asegurarse de seleccionar un sitio que acomodará estas medidas. **Las dimensiones del piso de la caseta son más pequeñas que el tejado; entonces, necesitará crear una superficie nivelada de:**

60187: 11' x 11'—3,14 m x 3,14 m (123 1/2 in. x 123 1/2 in.). Para una caseta con estas dimensiones, ver las páginas 4–5.

60236: 11' x 18.5'—3,14 m x 5,44 m (123 1/2 in. x 214 1/4 in.). Para una caseta con estas dimensiones, ver las páginas 6–7.

60237: 11' x 21'—3,14 m x 6,2 m (123 1/2 in. x 244 in.). Para una caseta con estas dimensiones, ver las páginas 8–9.

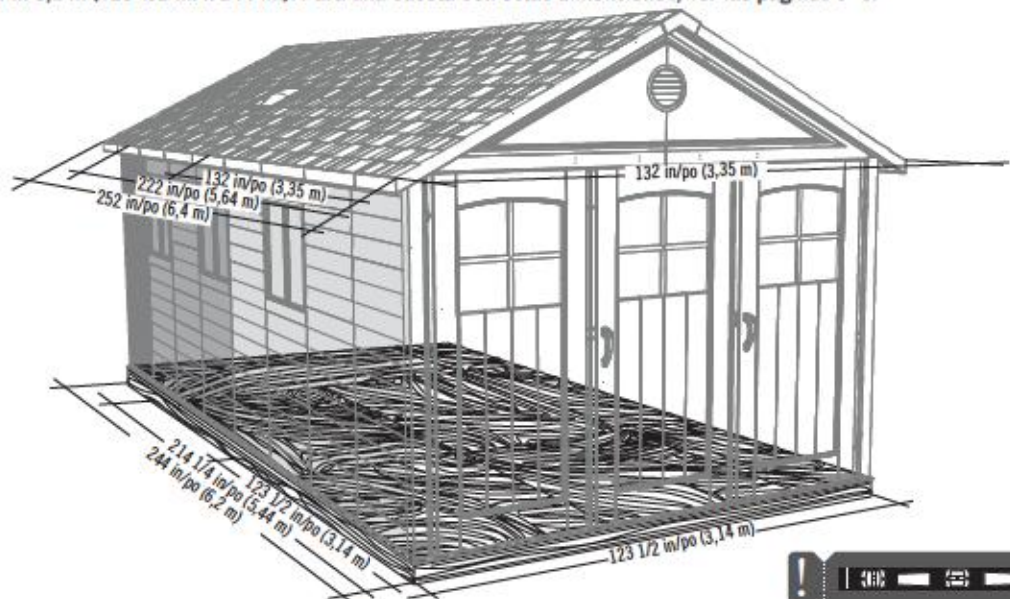

▶ SECTION 1 (CONTINUED) / SECTION 1 (SUITE) / SECCIÓN 1 (CONTINUACIÓN)

TOOLS, PARTS, AND HARDWARE REQUIRED / OUTILS, PIÈCES, ET QUINCAILLERIE REQUIS / INSTRUMENTAL, PIEZAS, Y HERRAJE REQUERIDOS



11 ft/pi x 11 ft/pi
(3,35 x 3,35 m)

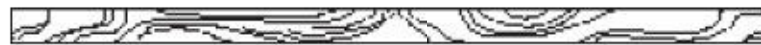

2 in/po x 4 in/po x 120 1/2 in/po (5,1 cm x 10,2 cm x 3,06 m) (x9)



2 in/po x 4 in/po x 123 1/2 in/po (5,1 cm x 10,2 cm x 3,14 m) (x2)

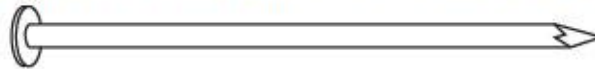

16d 3 in/po (16d x 7,62 cm) (x36)

1.2.1

11 ft/pi x 11 ft/pi (3,35 x 3,35 m) WOOD PLATFORM / PLATAFORMA DE MADERA / PLATE-FORME EN BOIS

- Ensure all lumber is treated and approved for outdoor use. Build frame to 123 1/2" x 123 1/2" (3,14 m x 3,14 m) (outside dimensions). You can also use the plywood as a flat surface when building this frame.
- Vérifier que votre bois d'œuvre à été traité et approuvé pour l'utilisation à l'extérieur. Construire un cadre de 3,14 m x 3,14 m (123 1/2 x 123 1/2 po) (dimensions extérieures). On peut aussi utiliser le contreplaqué comme une surface plate pendant l'assemblage de ce cadre.
- Asegurar de usar madera tratada y aprobada para el uso externo. Construir el armazón a 3,14 m x 3,14 m (123 1/2 x 123 1/2 in) (dimensiones exteriores). Se puede también usar el contrachapado como una superficie plana al ensamblar este armazón.

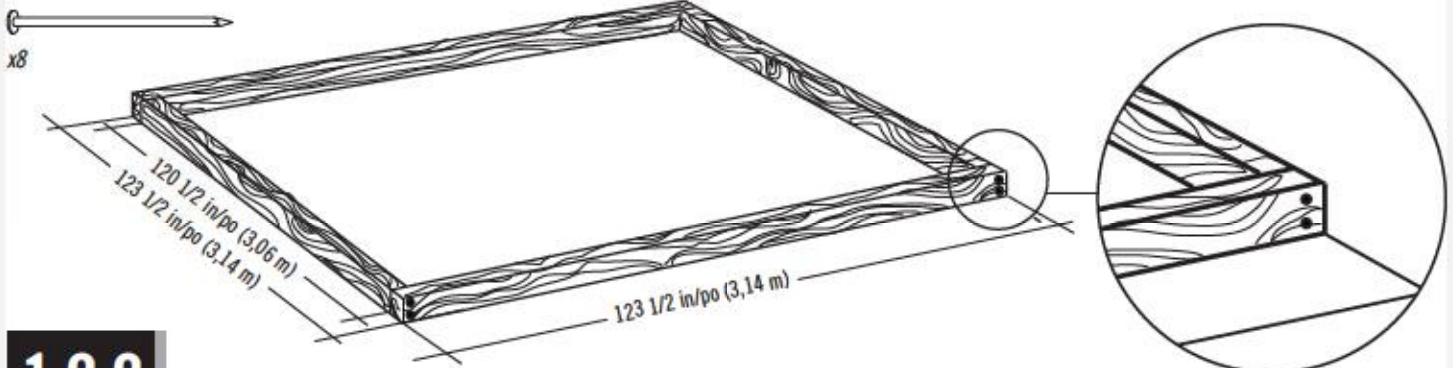

1.2.2

- To ensure studs are in the correct location for nailing plywood in the next step, start measuring from the corner 16" (40,1 cm), and then measure from center to center.
- Pour être sûr d'avoir les montants à l'endroit correct pour clouer le contreplaqué dans la prochaine étape, commencer à mesurer à partir de cette montant 40,1 cm (16 po) vers le centre du deuxième montant. Ensuite, mesurer de centre à centre pour les montants restants.
- Para asegurarse que los montantes están en las ubicaciones correctas para el contrachapado en el paso siguiente, comenzar a medir desde el borde del montante hasta el centro del próximo montante 40,1 cm (16 in.). Luego, tomar la medida de centro a centro en los montantes restantes.

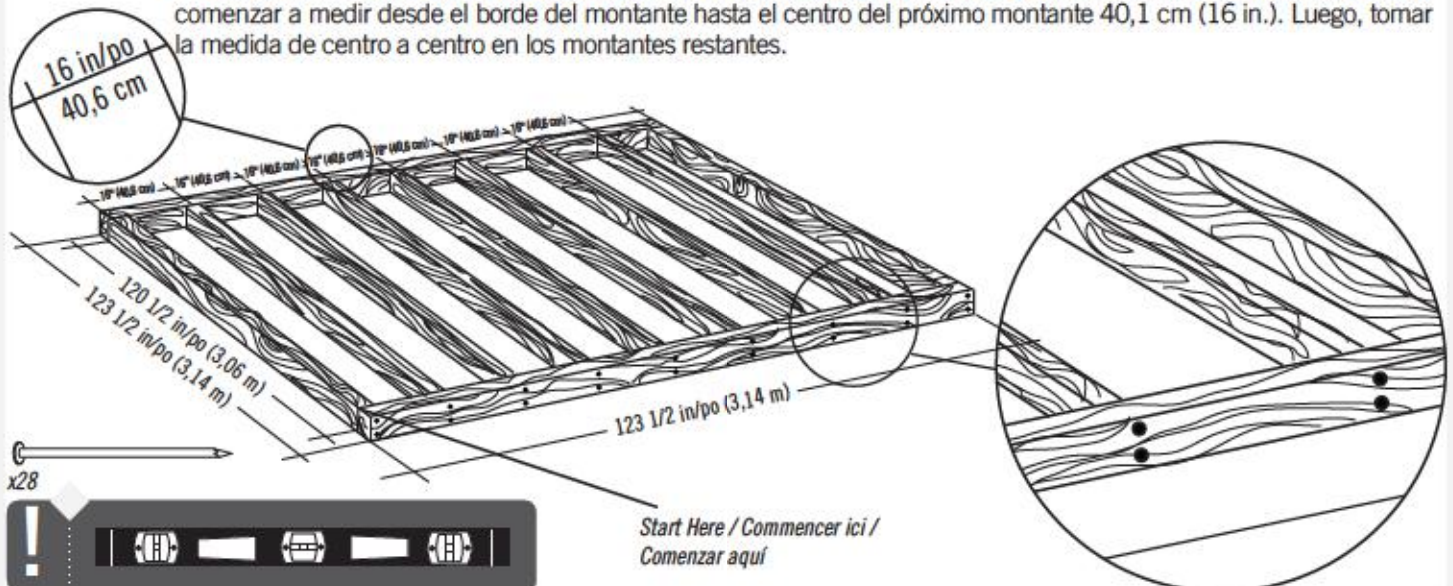

Start Here / Commencer ici /
Comenzar aquí

SECTION 1 (CONTINUED) / SECTION 1 (SUITE) / SECCIÓN 1 (CONTINUACIÓN)

TOOLS, PARTS, AND HARDWARE REQUIRED / OUTILS, PIÈCES, ET QUINCAILLERIE REQUIS / INSTRUMENTAL, PIEZAS, Y HERRAJE REQUERIDOS



5/16 in/po (8 mm)
Bit/Manche/Broca



48 in/po x 96 in/po x 3/4 in/po
(1,22 m x 2,44 m x 19 mm) (x2)



27 1/2 in/po x 96 in/po x 3/4 in/po
(69,9 cm x 2,44 m x 19 mm) (x2)



27 1/2 in/po x 27 1/2 in/po x 3/4 in/po
(69,9 cm x 70 cm x 19 mm) (x1)



8d 1 1/2 in/po Common Nail / clou / clavo (8d x 4 cm) (x76)

1.2.3

- Square the frame, measuring from corner to corner. **Measurement A & B should be about the same length.**
- Carrer le cadre en mesurant d'angle à angle. **La mesure « A » et « B » doivent être à peu près la même longueur.**
- Cuadrar el armazón midiendo de esquina a esquina. **La medida «A» y «B» deben ser aproximadamente el mismo largo.**

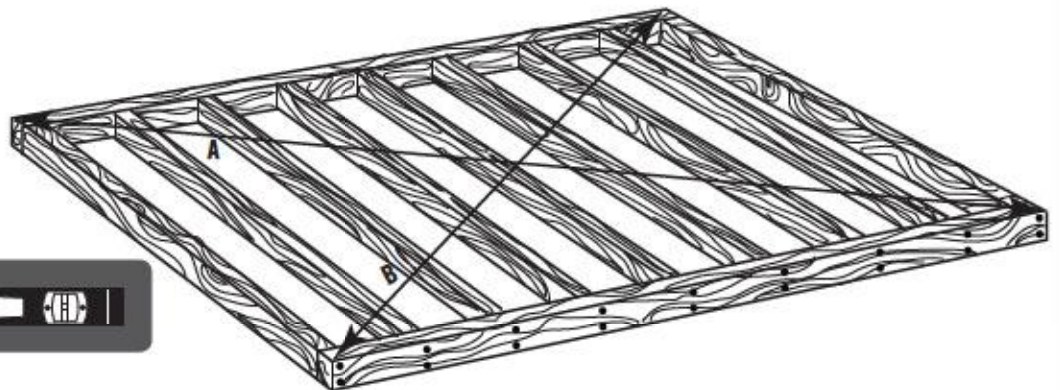

! A = B



1.2.4

- Using nails, fasten the plywood to the frame. Then, drill 5/16" (8 mm) holes for drainage.
- En utilisant des clous, attacher bien le contreplaqué au cadre. Ensuite, percer des trous de 8 mm pour le drainage.
- Usando unos clavos, sujetar el contrachapado al armazón. Entonces, taladrar agujeros de 8 mm para el drenaje.



x76

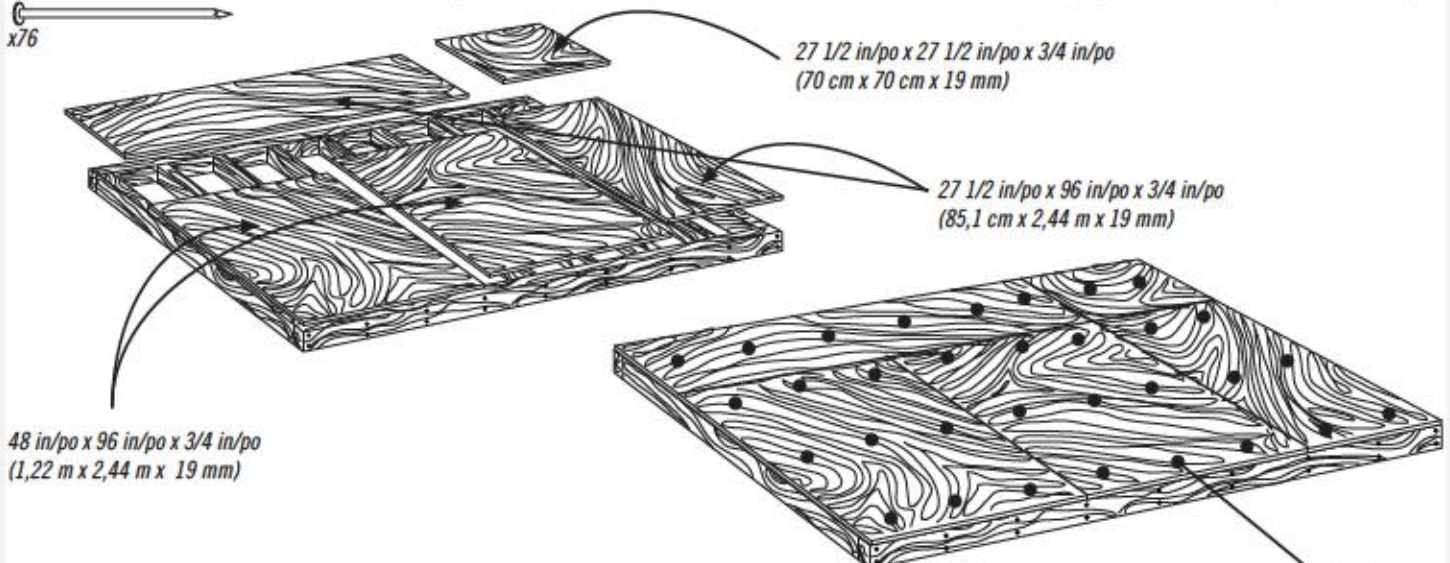

48 in/po x 96 in/po x 3/4 in/po
(1,22 m x 2,44 m x 19 mm)

27 1/2 in/po x 27 1/2 in/po x 3/4 in/po
(70 cm x 70 cm x 19 mm)

27 1/2 in/po x 96 in/po x 3/4 in/po
(85,1 cm x 2,44 m x 19 mm)

Drainage Holes
Trous de drainage
Agujeros para canalización

x32!



▶ SECTION 1 (CONTINUED) / SECTION 1 (SUITE) / SECCIÓN 1 (CONTINUACIÓN)

TOOLS, PARTS, AND HARDWARE REQUIRED / OUTILS, PIÈCES, ET QUINCAILLERIE REQUIS / INSTRUMENTAL, PIEZAS, Y HERRAJE REQUERIDOS



 2 in/po x 4 in/po x 120 1/2 in/po (5,1 cm x 10,2 cm x 3,06 m) (x15)

 2 in/po x 4 in/po x 214 1/4 in/po (5,1 cm x 10,2 cm x 5,44 m) (x2)

 16d 3 in/po (16d x 7,62 cm) (x60)

11 ft/pi x 18.5 ft/pi
(3,35 x 5,64 m)

1.2.1

11 ft/pi x 18.5 ft/pi (3,35 x 5,64 m) WOOD PLATFORM / PLATE-FORME EN BOIS / PLATAFORMA DE MADERA

- Ensure all lumber is treated and approved for outdoor use. Build frame to 123 1/2" x 123 1/2" (3,14 m x 3,14 m) (outside dimensions). You can also use the plywood as a flat surface when building this frame.
- Vérifier que le bois d'œuvre a été traité et approuvé pour l'utilisation à l'extérieur. Construire un cadre de 3,14 m x 3,14 m (123 1/2 x 123 1/2 po) (dimensions extérieures). On peut aussi utiliser le contreplaqué comme une surface plate pendant l'assemblage de ce cadre.
- Asegurarse de usar madera tratada y aprobada para el uso externo. Construir el armazón a 3,14 m x 3,14 m (123 1/2 x 123 1/2 in) (dimensiones exteriores). Se puede también usar el contrachapado como una superficie plana al ensamblar este armazón.

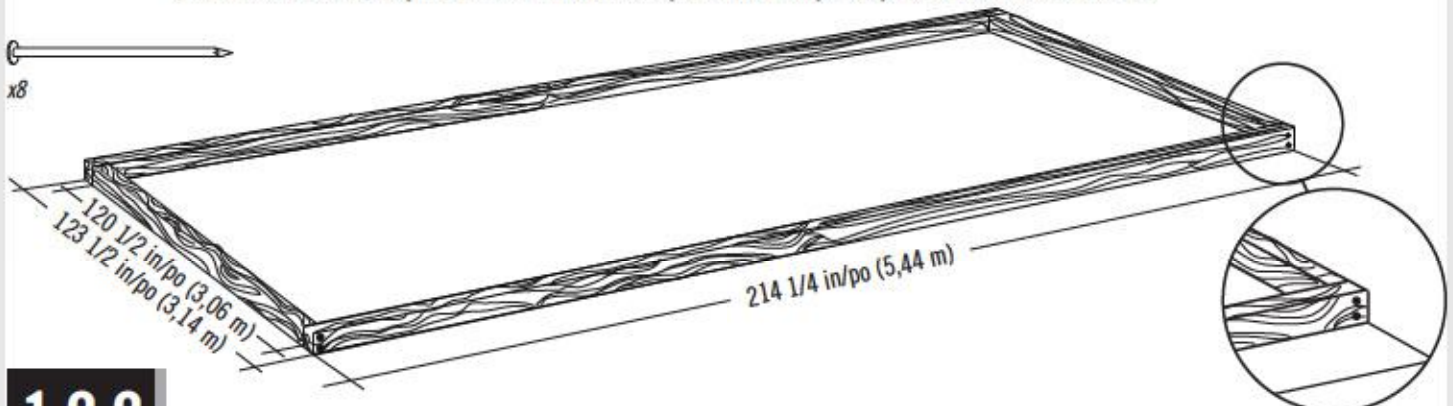

1.2.2

- To ensure studs are in the correct location for nailing plywood in the next step, start measuring from the corner 16" (40,1 cm), and then measure from center to center.
- Pour être sûr d'avoir les montants à l'endroit correct pour clouer le contreplaqué dans la prochaine étape, commencer à mesurer à partir de cette montant 40,1 cm (16 po) vers le centre du deuxième montant. Ensuite, mesurer de centre à centre pour les montants restants.
- Para asegurarse que los montantes están en las ubicaciones correctas para el contrachapado en el paso siguiente, comenzar a medir desde el borde del montante hasta el centro del próximo montante 40,1 cm (16 in.). Luego, tomar la medida de centro a centro en los montantes restantes.

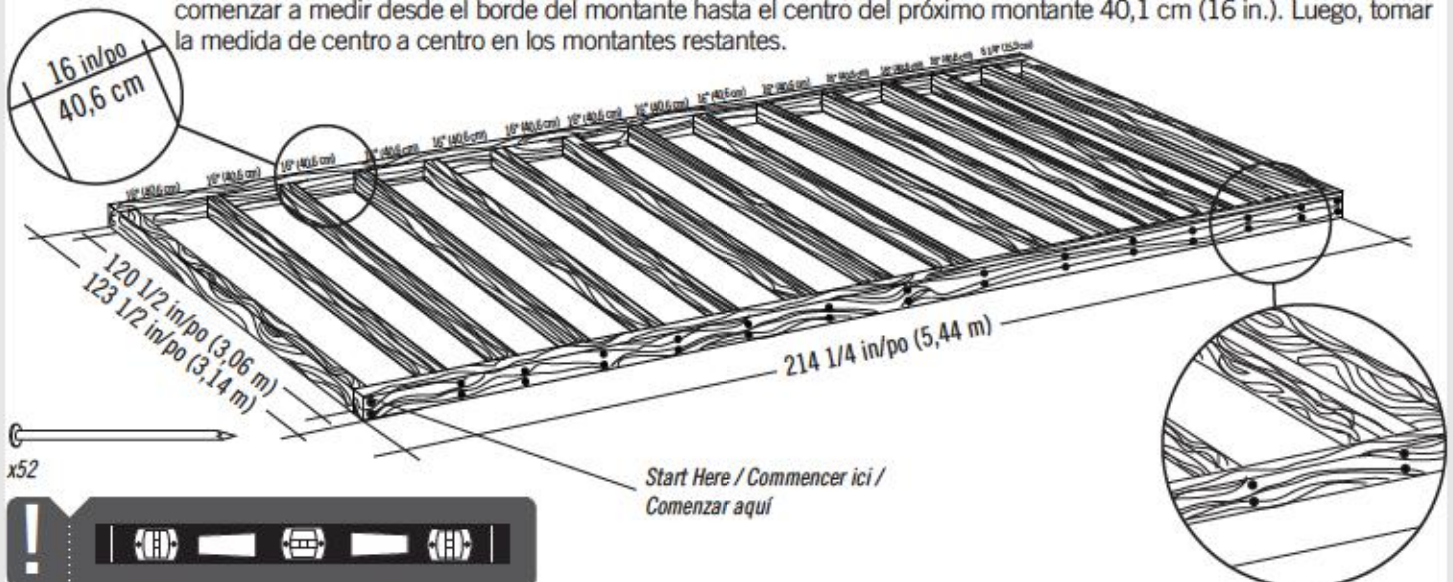

x52

Start Here / Commencer ici /
Comenzar aquí



SECTION 1 (CONTINUED) / SECTION 1 (SUITE) / SECCIÓN 1 (CONTINUACIÓN)

TOOLS, PARTS, AND HARDWARE REQUIRED / OUTILS, PIÈCES, ET QUINCAILLERIE REQUIS / INSTRUMENTAL, PIEZAS, Y HERRAJE REQUERIDOS



5/16 in/po (8 mm)
Bit/Manche/Broca



48 in/po x 96 in/po x 3/4 in/po
(1,22 m x 2,44 m x 19 mm) (x4)



27 1/2 in/po x 96 in/po x 3/4 in/po
(69,9 cm x 2,44 m x 19 mm) (x2)



22 1/4 in/po x 96 in/po x 3/4 in/po
(56,5 cm x 2,44 m x 19 mm) (x2)



27 1/2 in/po x 22 1/4 in/po x 3/4 in/po
(69,9 cm x 56,5 cm x 19 mm) (x1)



8d 1 1/2 in/po Common Nail / clou / clavo (8d x 4 cm) (x170)

1.2.3

- Square the frame, measuring from corner to corner. **Measurement A & B should be about the same length.**
- Carrer le cadre en mesurant d'angle à angle. **La mesure « A » et « B » doivent être à peu près la même longueur.**
- Cuadrar el armazón midiendo de esquina a esquina. **La medida «A» y «B» deben ser aproximadamente el mismo largo.**

! A = B

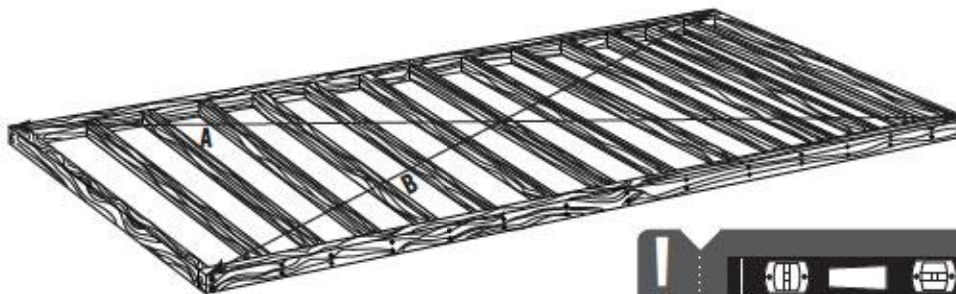

1.2.4

- Using nails, fasten the plywood to the frame. Then, drill 5/16" (8 mm) holes between the studs for drainage.
- En utilisant des clous, attacher bien le contreplaqué au cadre. Ensuite, percer des trous de 8 mm entre les montants pour le drainage.
- Usando unos clavos, sujetar el contrachapado al armazón. Entonces, taladrar agujeros de 8 mm entre los montantes para el drenaje.

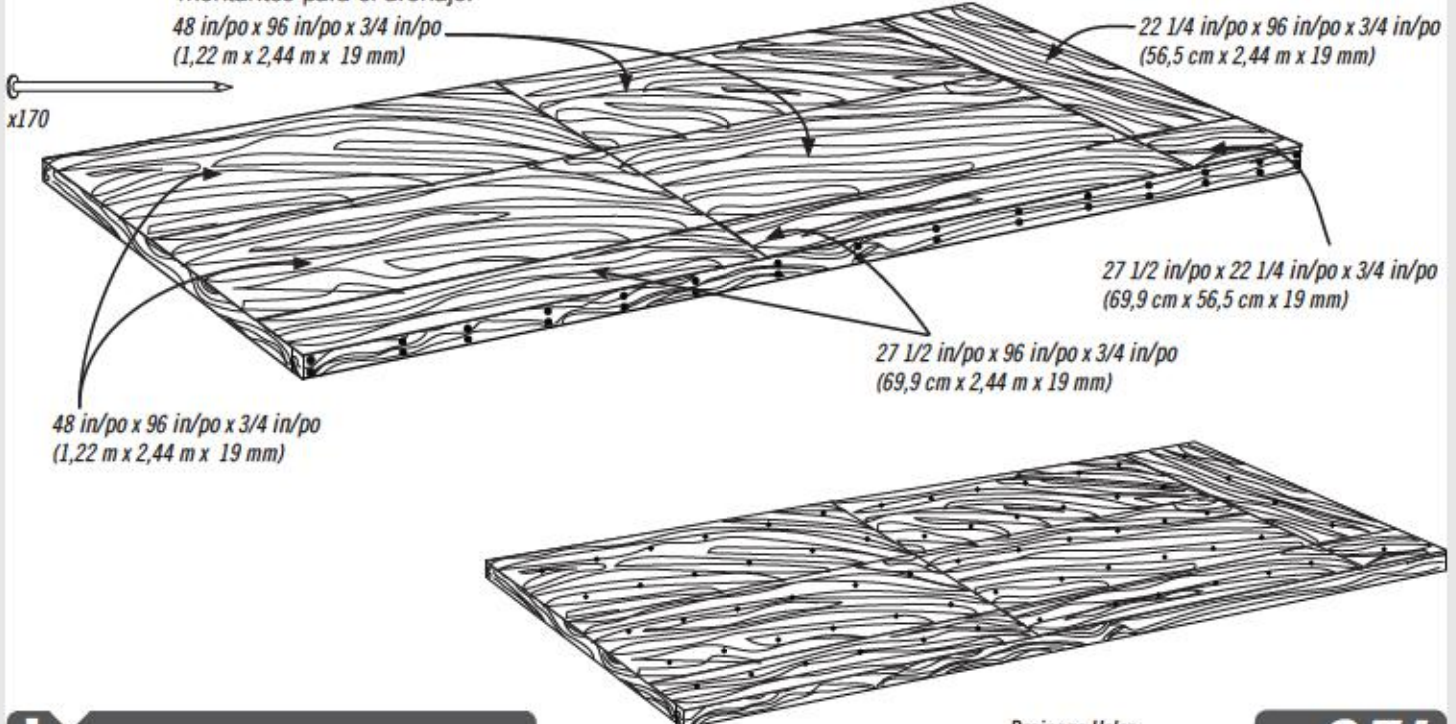

Drainage Holes
Trous de drainage
Agujeros para canalización

x65!

▶ SECTION 1 (CONTINUED) / SECTION 1 (SUITE) / SECCIÓN 1 (CONTINUACIÓN)

TOOLS, PARTS, AND HARDWARE REQUIRED / OUTILS, PIÈCES, ET QUINCAILLERIE REQUIS / INSTRUMENTAL, PIEZAS, Y HERRAJE REQUERIDOS



2 in/po x 4 in/po x 120 1/2 in/po (5,1 cm x 10,2 cm x 3,06 m) (x17)



2 in/po x 4 in/po x 243 1/2 in/po (5,1 cm x 10,2 cm x 6,19 m) (x2)



16d 3 in/po (16d x 7,62 cm) (x76)

11 ft/pi x 21 ft/pi
(3,35 x 6,4 m)

1.2.1

11 ft/pi x 21 ft/pi (3,35 x 6,64 m) WOOD PLATFORM / PLATE-FORME EN BOIS / PLATAFORMA DE MADERA

- Ensure all lumber is treated and approved for outdoor use. Build frame to 123 1/2" x 123 1/2" (3,14 m x 3,14 m) (**outside dimensions**). You can also use the plywood as a flat surface when building this frame.
- Vérifier que le bois d'œuvre a été traité et approuvé pour l'utilisation à l'extérieur. Construire le cadre de 3,14 m x 3,14 m (123 1/2 po x 123 1/2 po) (**dimensions extérieures**). On peut aussi utiliser le contreplaqué comme une surface plate pendant l'assemblage de ce cadre.
- Asegurarse de usar madera tratada y aprobada para el uso externo. Construir el armazón a 3,14 m x 3,14 m (123 1/2 in x 123 1/2 in) (**dimensiones exteriores**). Se puede también usar el contrachapado como una superficie plana al ensamblar este armazón.

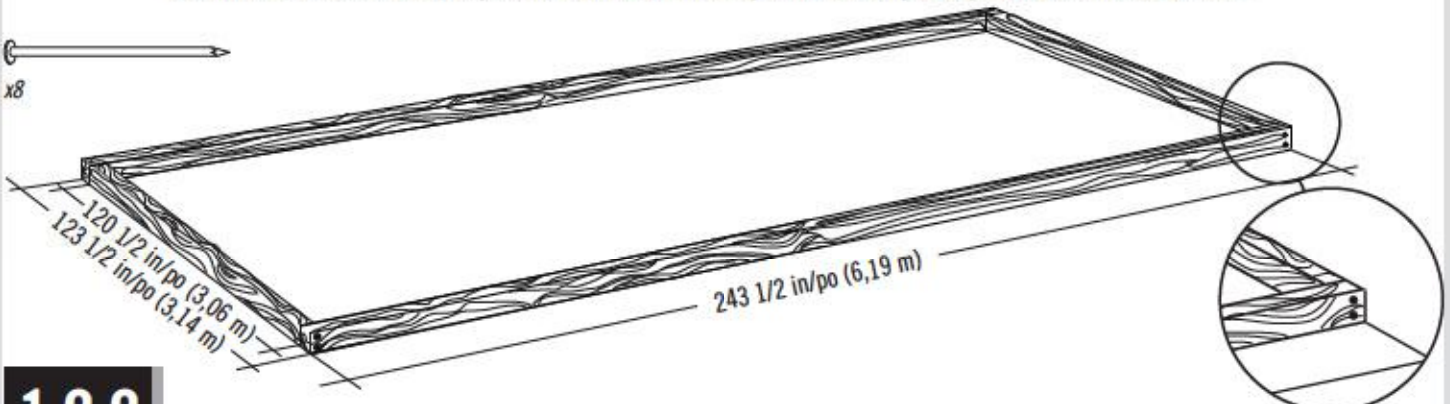

1.2.2

- To ensure studs are in the correct location for nailing plywood in the next step, start measuring from the corner 16" (40,1 cm), and then measure from center to center.
- Pour être sûr d'avoir les montants à l'endroit correct pour clouer le contreplaqué dans la prochaine étape, commencer à mesurer à partir de cette montant 40,1 cm (16 po) vers le centre du deuxième montant. Ensuite, mesurer de centre à centre pour les montants restants.
- Para asegurarse que los montantes están en las ubicaciones correctas para el contrachapado en el paso siguiente, comenzar a medir desde el borde del montante hasta el centro del próximo montante 40,1 cm (16 in.). Luego, tomar la medida de centro a centro en los montantes restantes.

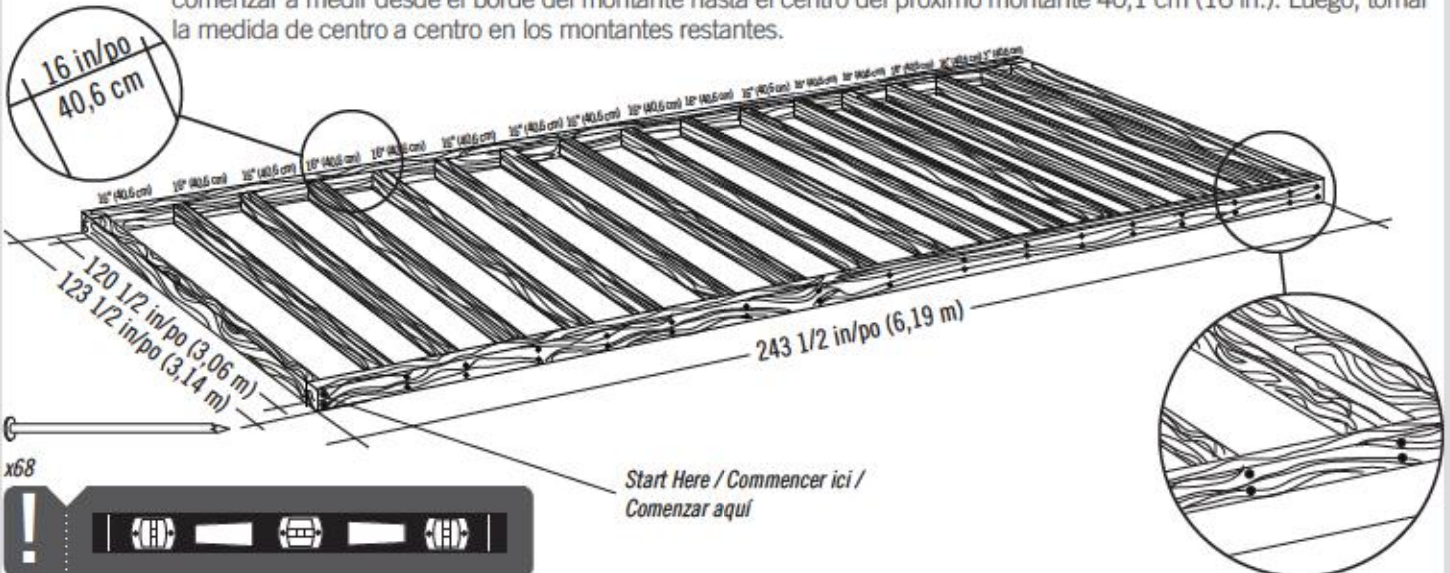

SECTION 1 (CONTINUED) / SECTION 1 (SUITE) / SECCIÓN 1 (CONTINUACIÓN)

TOOLS, PARTS, AND HARDWARE REQUIRED / OUTILS, PIÈCES, ET QUINCAILLERIE REQUIS / INSTRUMENTAL, PIEZAS, Y HERRAJE REQUERIDOS



5/16 in/po (8 mm)
Bit/Manche/Broca



48 in/po x 96 in/po x 3/4 in/po
(1,22 m x 2,44 m x 19 mm) (x4)



48 in/po x 51 1/2 in/po x 3/4 in/po
(1,22 m x 1,40 m x 19 mm) (x2)



27 1/2 in/po x 96 in/po x 3/4 in/po
(70 cm x 2,44 m x 19 mm) (x2)



27 1/2 in/po x 51 1/2 in/po x 3/4 in/po
(70 cm x 1,40 m x 19 mm) (x1)



8d 1 1/2 in/po Common Nail (8d x 4 cm) (x190)

1.2.3

- Square the frame, measuring from corner to corner. **Measurement A & B should be about the same length.**
- Carrer le cadre en mesurant d'angle à angle. **La mesure « A » et « B » doivent être à peu près la même longueur.**
- Cuadrar el armazón midiendo de esquina a esquina. **La medida «A» y «B» deben ser aproximadamente el mismo largo.**



! A = B

1.2.4

- Using nails, fasten the plywood to the frame. Then, drill 5/16" (8 mm) holes for drainage.
- En utilisant des clous, attacher bien le contreplaqué au cadre. Ensuite, percer des trous de 8 mm pour le drainage.
- Usando unos clavos, sujetar el contrachapado al armazón. Entonces, taladrar agujeros de 8 mm para el drenaje.



x190

48 in/po x 96 in/po x 3/4 in/po
(1,22 m x 2,44 m x 19 mm)

48 in/po x 96 in/po x 3/4 in/po
(1,22 m x 2,44 m x 19 mm)

48 in/po x 51 1/2 in/po x 3/4 in/po
(70 cm x 70 cm x 19 mm)

27 1/2 in/po x 51 1/2 in/po x 3/4 in/po
(70 cm x 70 cm x 19 mm)

27 1/2 in/po x 96 in/po x 3/4 in/po
(85,1 cm x 2,44 m x 19 mm)

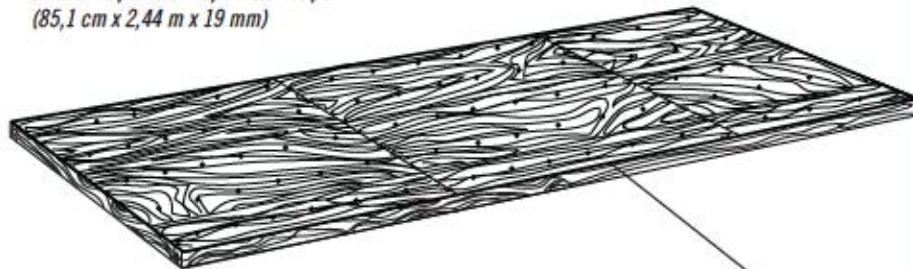

Drainage Holes
Trous de drainage
Agujeros para canalización

x75!



2

TRUSS ASSEMBLY / ASSEMBLAGE DES FERMES / ENSAMBLE DE LAS CERCHAS



HARDWARE REQUIRED / QUINCAILLERIE REQUISE / HERRAJE REQUERIDO

Hardware Bag / Sac de quincaillerie / Bolsa de herraje

(60187—11', 60236—18.5', 60237—21')



(60236—18.5')



(60237—21')



ADJ (x40, x70, x80)

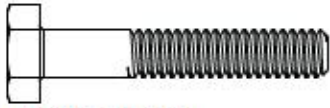

AAK (x40, x70, x80)



AHT (x8, x14, x16)

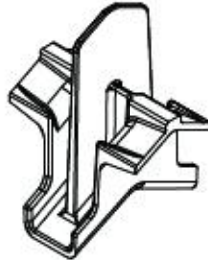

AIP (x4, x7, x8)



• The quantities of the hardware shown below vary due to the size of your shed. Bag **DTQ** is used for all three sheds. Bag **DTR** is used for the 18.5' (5,6 m) shed. Bags **DTR** are used for both the 18.5' (5,6 m) and 21' (6,4 m) sheds.
 • Les quantités de la quincaillerie illustrées à gauche varient selon le longueur de votre abri. Le sac **DTQ** est utilisé pour tous les trois abris. Le sac **BGV** est utilisé pour l'abri de 5,6 m. Les sacs **DTR** sont utilisés pour les abris de 5,6 m et 6,4 m.
 • Las cantidades de herraje ilustradas a la izquierda varían según el largo de su caseta. Se usa la bolsa **DTQ** para todas las tres casetas. Se usa la bolsa **BGV** para la caseta de 5,6 m. Se usan las bolsas **DTR** para la caseta de 6,4 m.



PARTS REQUIRED / PIÈCES REQUISES / PIEZAS REQUERIDAS

Metal Parts / Pièces en métal / Piezas de metal



71 11/16 in/po (1,82 m)

AFH (x8, x14, x16)



79 1/2 in/po (2,02 m)

AFG (x4, x7, x8)



79 1/2 in/po (2,02 m)

AFQ (x8, x14, x16)



20 1/8 in/po (51 cm)

AFP (x8, x14, x16)



TOOLS REQUIRED / OUTILS REQUIS / INSTRUMENTAL REQUERIDO



7/16 in/po (11 mm) (x2)

► SECTION 2 (CONTINUED) / SECTION 2 (SUITE) / SECCIÓN 2 (CONTINUACIÓN)

TOOLS AND HARDWARE REQUIRED / OUTILS ET QUINCAILLERIE REQUIS / INSTRUMENTAL Y HERRAJE REQUERIDOS

7/16 in/po (x2)
(11 mm (x2))

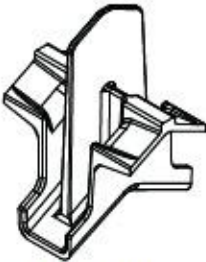

AIP (x4, x7, x8)

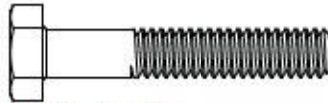

AAK (x8, x14, x16)



ADJ (x8, x14, x16)

2.1

- Place a **Truss Connector (AIP)** down inside the ends of two **Truss Gutter Channels (AFH)** as shown.
- Insérer un **connecteur de fermes (AIP)** dans les extrémités de deux **canaux de gouttière (AFH)** comme illustré.
- Colocar un **conector de canales (AIP)** en los extremos de dos **canalones de la cercha (AFH)** como se muestra.

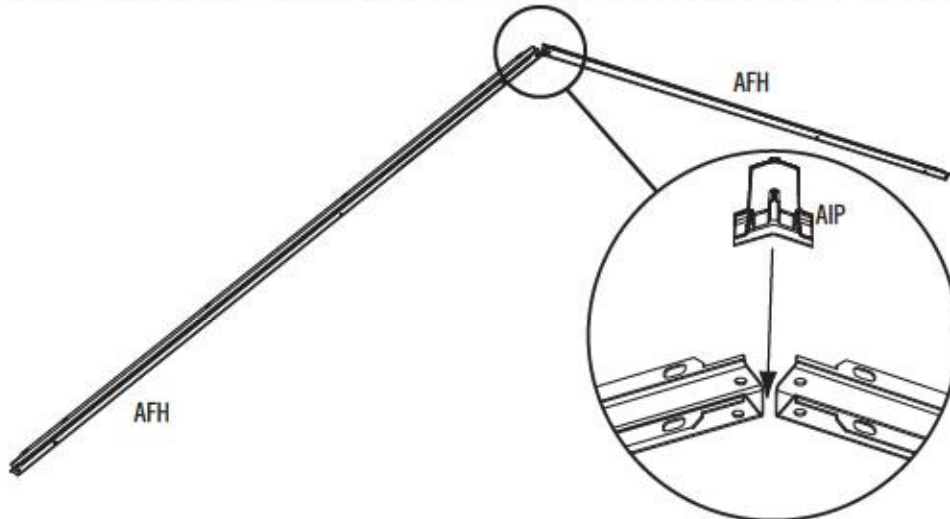

2.2

- Insert two (2) **Bolts (AAK)** through the first **Vertical Truss Brace (AFP)**, the holes in the Truss Gutter Channels, over the Truss Connector, and out through the Truss Gutter Channels and second **Vertical Truss Support (AFP)**. Secure with two **Cap Nuts (ADJ)**. **Do not overtighten the Nuts.**
- Insérer deux (2) **boulons (AAK)** à travers le premier **support vertical (AFP)**, les trous dans les canaux de gouttière, par-dessus le connecteur de fermes, et à travers les canaux et le deuxième **support vertical (AFP)**. Attacher-les bien à l'aide de deux **écrous borgnes (ADJ)**. **Ne pas trop serrer.**
- Insertar dos (2) **Pernos (AAK)** a través del primer **soporte vertical (AFP)**, los agujeros en los canalones de la cercha, encima del conector de canales, y a través de los canalones de la cercha y el segundo **soporte vertical (AFP)**. Sujetarlos con dos **tuercas ciegas (ADJ)**. **No apretar demasiado las tuercas.**

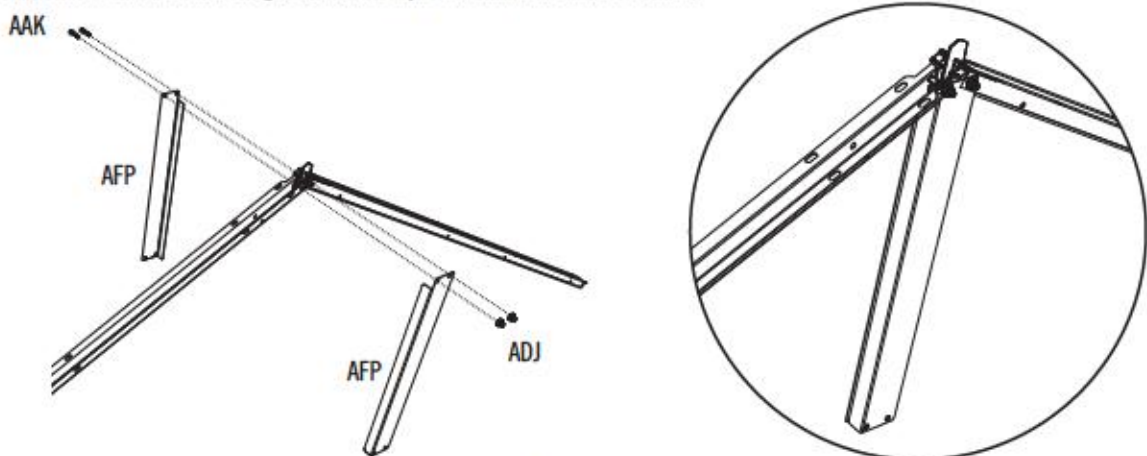

► SECTION 2 (CONTINUED) / SECTION 2 (SUITE) / SECCIÓN 2 (CONTINUACIÓN)

TOOLS AND HARDWARE REQUIRED / OUTILS ET QUINCAILLERIE REQUIS / INSTRUMENTAL Y HERRAJE REQUERIDOS



7/16 in/po (x2)
(11 mm (x2))

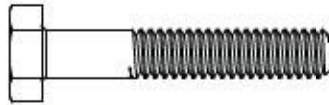

AAK (x16, x28, x32)



ADJ (x16, x28, x32)

2.3

- Secure a **Horizontal Truss Brace (AFG)** to the Channels and the Vertical Truss Braces using four (4) **Bolts (AAK)** and **Cap Nuts (ADJ)**. **Do not overtighten the Nuts.**
- Attacher bien un **support horizontal (AFG)** aux canaux et aux supports verticaux à l'aide de quatre (4) **boulons (AAK)** et **écrous borgnes (ADJ)**. **Ne pas trop serrer.**
- Sujetar un **soporte horizontal (AFG)** a los canalones y los soportes verticales usando cuatro (4) **pernos (AAK)** y **tuercas ciegas (ADJ)**. **No apretar demasiado las tuercas.**

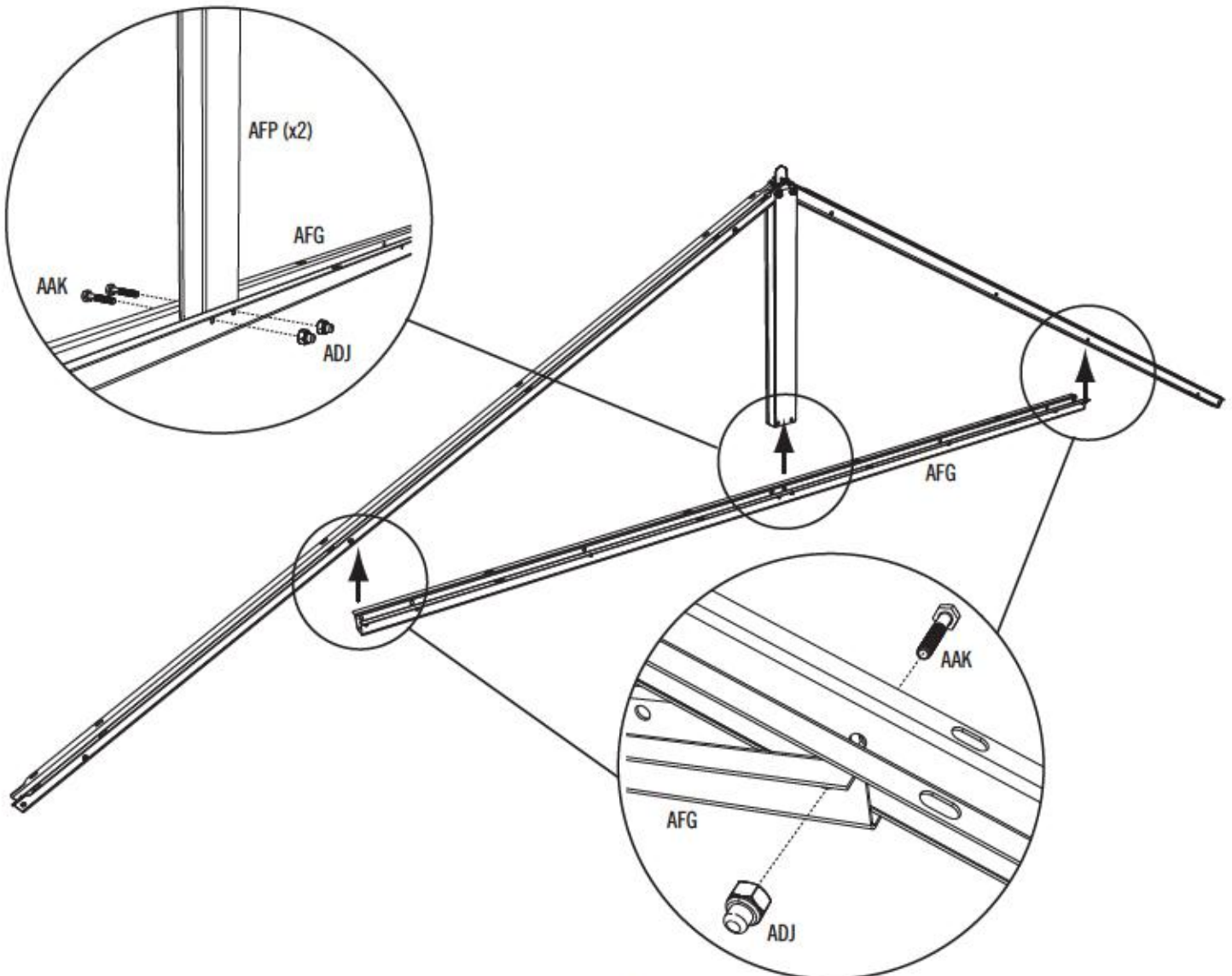

► SECTION 2 (CONTINUED) / SECTION 2 (SUITE) / SECCIÓN 2 (CONTINUACIÓN)

TOOLS AND HARDWARE REQUIRED / OUTILS ET QUINCAILLERIE REQUIS / INSTRUMENTAL Y HERRAJE REQUERIDOS



7/16 in/po (x2)
(11 mm (x2))

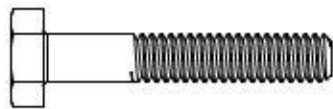

AAK (x16, x28, x32)



ADJ (x16, x28, x32)



AHT (x8, x14, x16)

2.4

- Attach a **Wall Support Channel (AFQ)** to each end of the Truss Assembly using the hardware included. **Do not overtighten.**
- Attacher un **canal de support à mur (AFQ)** à chaque extrémité de l'ensemble de la ferme à l'aide de la quincaillerie incluse. **Ne pas trop serrer.**
- Sujeter un **canal de soporte para el muro (AFQ)** a cada extremo del conjunto de la cercha usando el herraje incluido. **No apretar demasiado.**

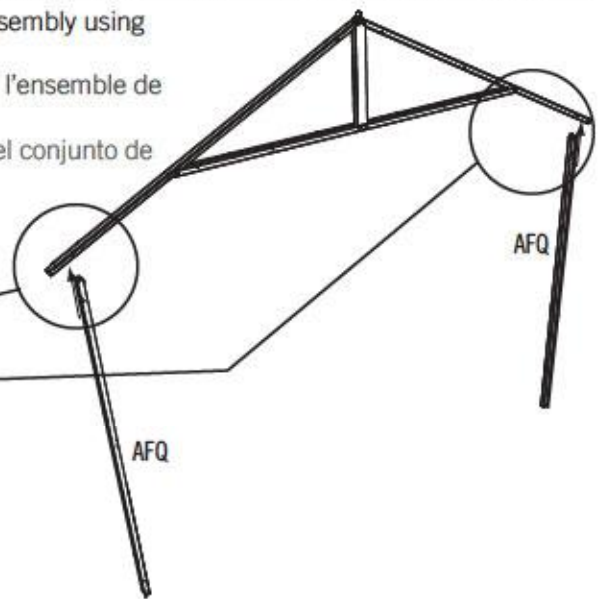
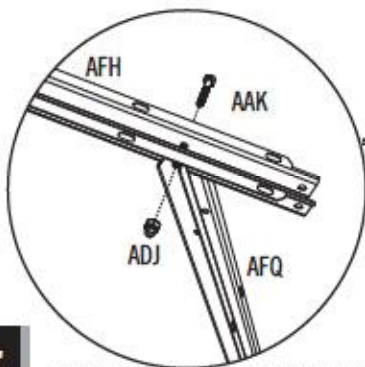

2.5

- Attach a **Floor Bracket (AHT)** to the bottom of each Wall Support Channel. **Hand tighten only at this point. Repeat this section three times for the 11'x11' (3.4 m x 3.4 m) shed, six times for the 11'x18.5' (3.4 m x 5.6 m) shed, or seven times for the 11'x21' (3.4 m x 6.4 m) shed.**
- Attacher un **support à plancher (AHT)** à l'extrémité inférieure de chaque canal de support à mur. **Serrer-les à la main en ce moment. Répéter cette section trois fois pour l'abri de 3,4 m x 3,4 m, six fois pour l'abri de 3,4 m x 5,6 m, ou sept fois pour l'abri de 3,4 m x 6,4 m.**
- Sujeter un **soporte para el piso (AHT)** al extremo inferior de cada canal de soporte para el muro. **Apretarlos sólo a mano en este momento. Repetir esta sección tres veces para la caseta de 3,4 m x 3,4 m, seis veces para la caseta de 3,4 m x 5,6 m, o siete veces para la caseta de 3,4 m x 6,4 m.**

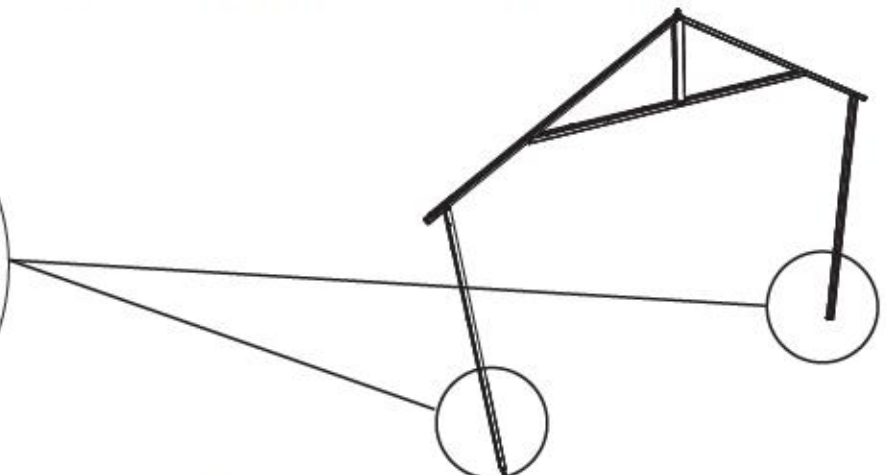
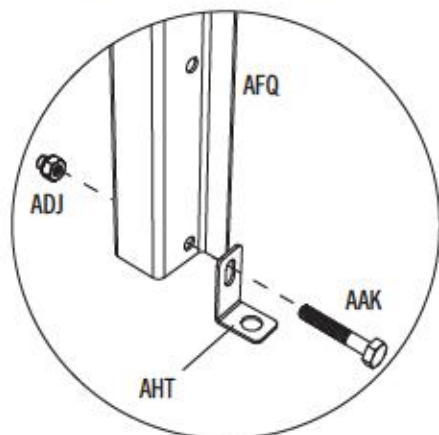

3

GABLE ASSEMBLY / ASSEMBLAGE DES PIGNONS / ENSAMBLE DE LAS FACHADAS



HARDWARE REQUIRED / QUINCAILLERIE REQUISE / HERRAJE REQUERIDO

Hardware Bag / Sac de quincaillerie / Bolsa de herraje



AEE (x10)

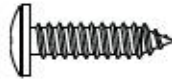

ADW (x10)

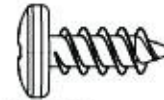

ADZ (x8)



AGP (x2)

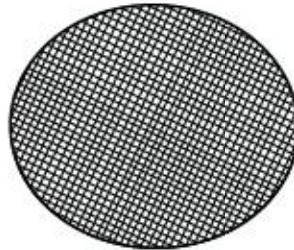

AIQ (x2)



PARTS REQUIRED / PIÈCES REQUISES / PIEZAS REQUERIDAS

Plastic Parts / Pièces en plastique / Piezas de plástico

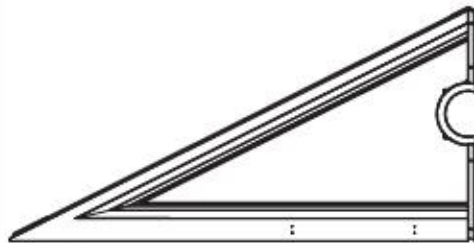

AGI (x2)

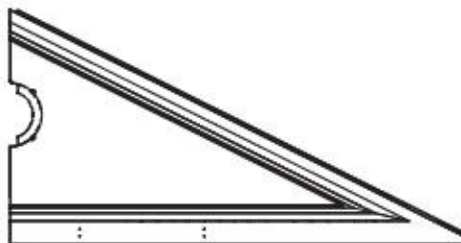

AGH (x2)



TOOLS REQUIRED / OUTILS REQUIS / INSTRUMENTAL REQUERIDO



► SECTION 3 (CONTINUED) / SECTION 3 (SUITE) / SECCIÓN 3 (CONTINUACIÓN)

TOOLS AND HARDWARE REQUIRED / OUTILS ET QUINCAILLERIE REQUIS / INSTRUMENTAL Y HERRAJE REQUERIDOS

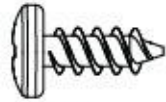

ADZ (x8)



AEE (x10)

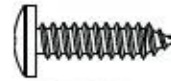

ADW (x10)

3.1

- Set the edge of **Gable Side A (AGI)** over the edge of **Gable Side B (AGH)**, and align the four holes.
- Mettre le bord du **pignon A (AGI)** sur le bord du **pignon B (AGH)**, et aligner les quatre trous.
- Colocar el borde de la **fachada A (AGI)** encima del borde de la **fachada B (AGH)**, y alinear los cuatro agujeros.

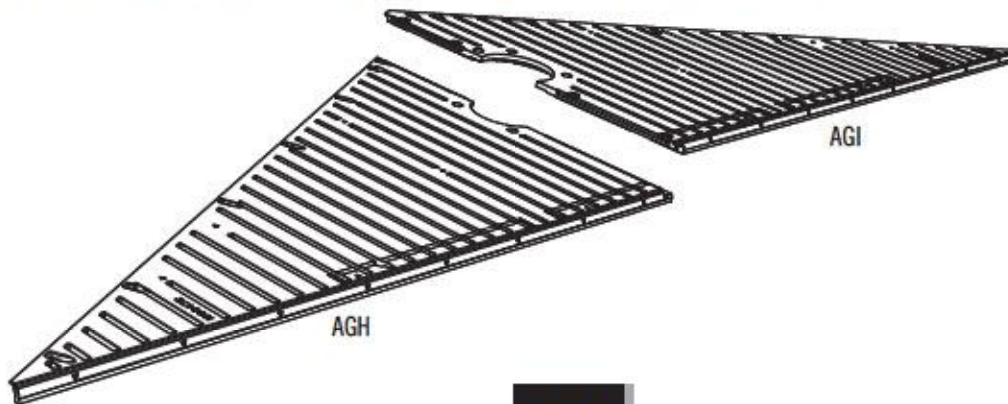

3.2

- Secure Gable Side A to Gable Side B using the hardware included.
- Attacher le pignon A au pignon B à l'aide de la quincaillerie incluse.
- Sujetar la fachada A a la fachada B usando el herraje incluido.

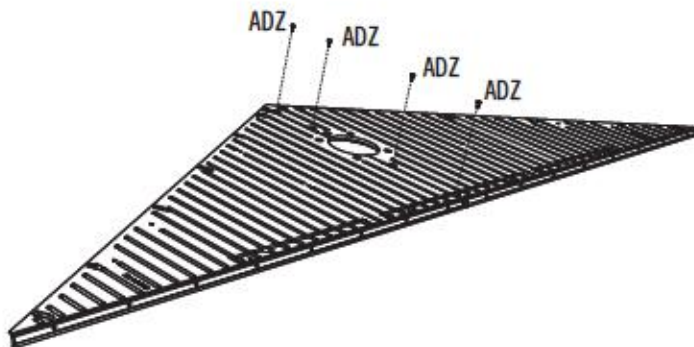

3.3

- Place a **Screen (AIQ)** over a **Vent (AGP)**. Set the Gable Assembly over the Screen and Vent so the holes in the Gable align with those in the Vent. Secure with the hardware included. **Repeat these steps for the second Gable.**
- Mettre un **mosquitaire (AIQ)** sur un **évent (AGP)**. Mettre le pignon sur le mosquitaire et l'évent pour que les trous dans le pignon s'alignent avec ceux de l'évent. Attacher l'évent au pignon à l'aide des accessoires inclus. **Répéter ces étapes pour le deuxième pignon.**
- Colocar un **mosquitero (AIQ)** encima de una **ventila (AGP)**. Colocar la fachada encima del mosquitero y la ventila para que los agujeros en la fachada se alineen con ellos en la ventila. Sujetar la la ventila a la fachada usando el herraje incluido. **Repitir estos pasos para la segunda fachada.**

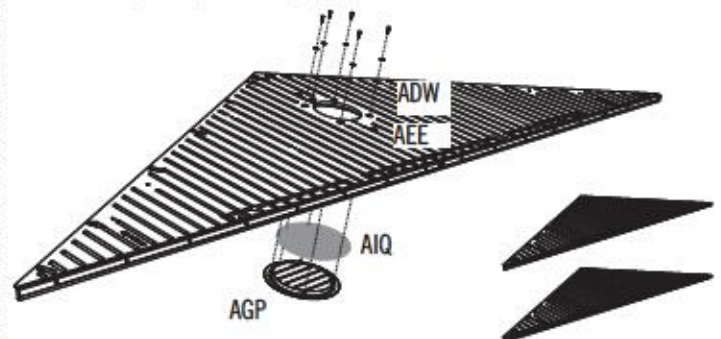

4 LEFT DOOR ASSEMBLY / ENSAMBLE DE LA PUERTA IZQUIERDA / ASSEMBLAGE DE LA PORTE GAUCHE



HARDWARE REQUIRED / HERRAJE REQUERIDO / QUINCAILLERIE REQUISE

Hardware Bags / Bolsas de herraje / Sacs de quincaillerie

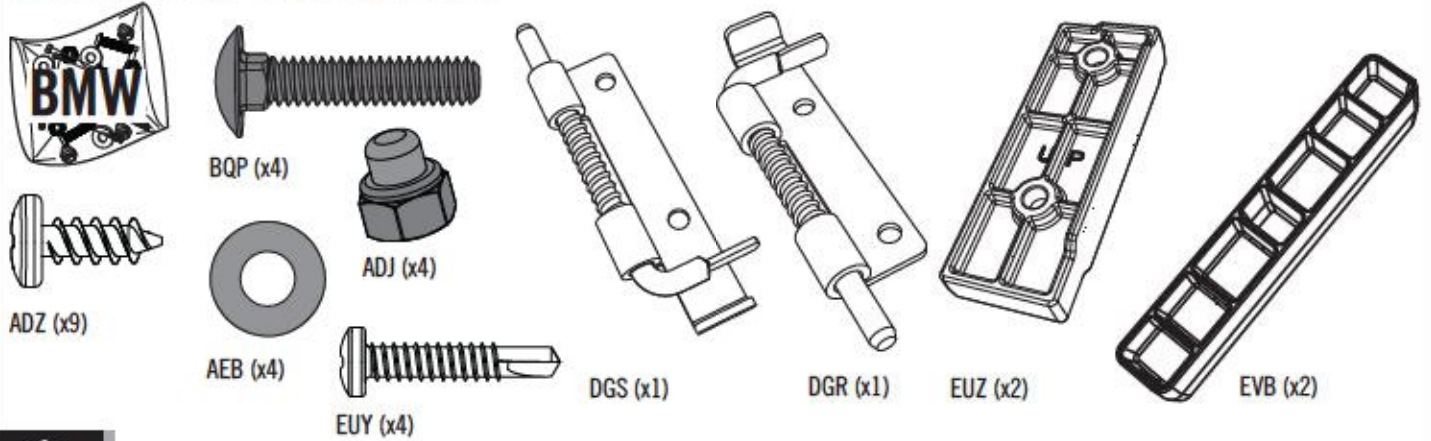

PARTS REQUIRED / PIEZAS REQUERIDAS / PIÈCES REQUISES

Metal Parts / Piezas de metal / Pièces en métal

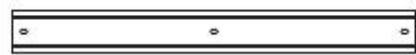

26 1/4 in/po (66,7 cm)

AFB (x3)

Plastic Parts / Piezas de plástico / Pièces en plastique

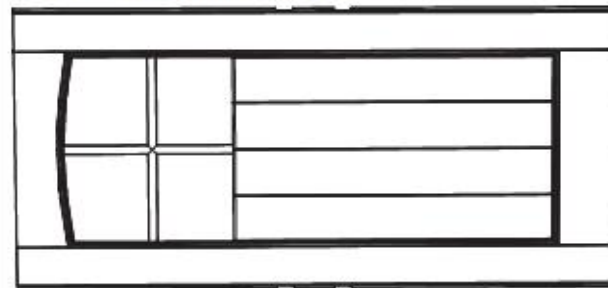

AGO (x1)



TOOLS REQUIRED / INSTRUMENTAL REQUERIDO / OUTILS REQUIS



7/16" (11 mm)



► SECTION 4 (CONTINUED) / SECCIÓN 4 (CONTINUACIÓN) / SECTION 4 (SUITE)

TOOLS AND HARDWARE REQUIRED / INSTRUMENTAL Y HERRAJE REQUERIDOS / OUTILS ET QUINCAILLERIE REQUIS

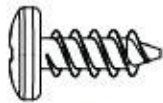

ADZ (x9)

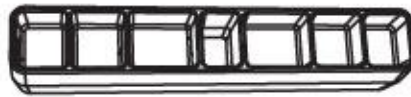

EVB (x2)

4.1

- Attach the three (3) **Metal Braces (AFB)** to the back of the **Left Door (AGO)**.
- Sujetar tres (3) **soportes de metal (AFB)** a la cara trasera de la **puerta izquierda (AGO)**.
- Attacher trois (3) **supports en métal (AFB)** au côté arrière de la **porte gauche (AGO)**.

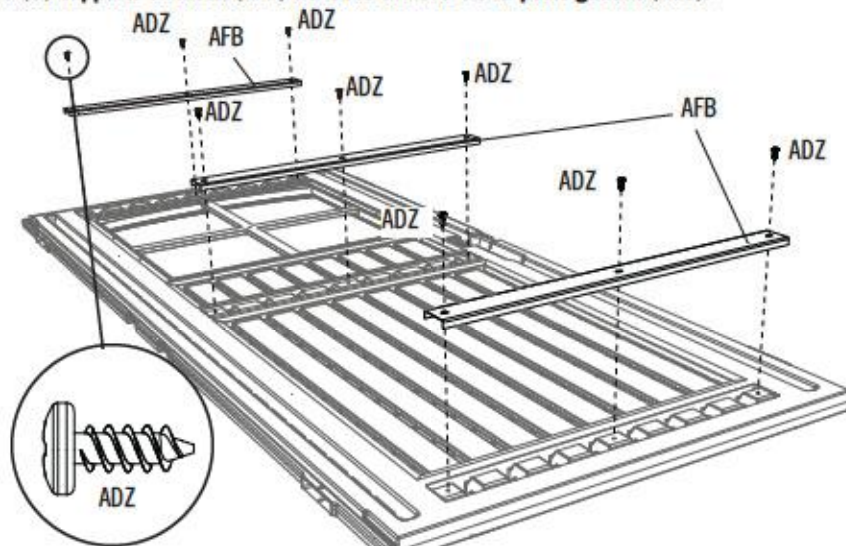

4.2

- Insert the **Spacers (EVB)** into the slots on the left side of the back of the **Left Door** as shown.
- Insérer les **pièces d'écartement (EVB)** dans les fentes sur le côté gauche du dos de la **porte gauche** comme illustré.
- Insertar los **espaciadores (EVB)** en las ranuras en el lado izquierdo del reverso de la **puerta izquierda** como se muestra.

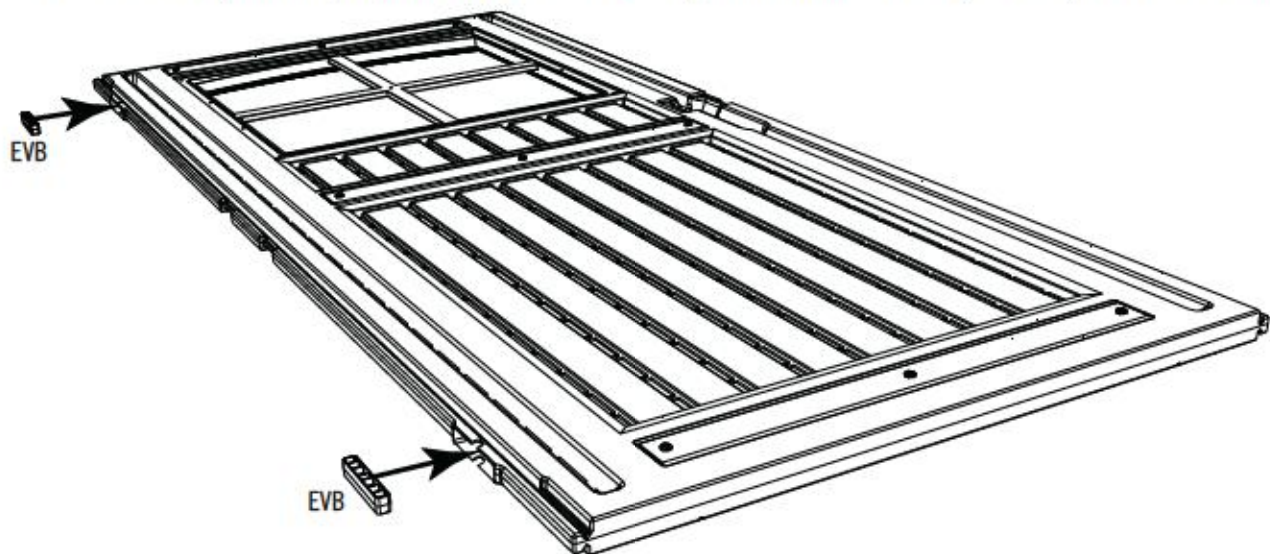

► SECTION 4 (CONTINUED) / SECCIÓN 4 (CONTINUACIÓN) / SECTION 4 (SUITE)

TOOLS AND HARDWARE REQUIRED / INSTRUMENTAL Y HERRAJE REQUERIDOS / OUTILS ET QUINCAILLERIE REQUIS



7/16"
(11 mm)



BQP (x4)



AEB (x4)



ADJ (x4)

4.3

- Slide the **Left-to-Center Door Hinge (EVA)** down over the left edge of the Left Door until the holes in the Hinge align with those in the edge of the Door. **Note the direction of the small Hinge.**
- Faire glisser la **charnière de la porte gauche/porte centrale (EVA)** sur le bord de la porte gauche jusqu'à ce que les trous dans la charnière s'alignent avec ceux dans le bord de la porte. **Notez la direction de la petite charnière.**
- Deslizar la **bisagra de la puerta izquierda/puerta central (EVA)** sobre el borde de la puerta izquierda hasta que los agujeros en la bisagra se alineen con ellos en el borde de la puerta. **Note la dirección de la bisagra pequeña.**

- Hinge
- Charnière
- Bisagra

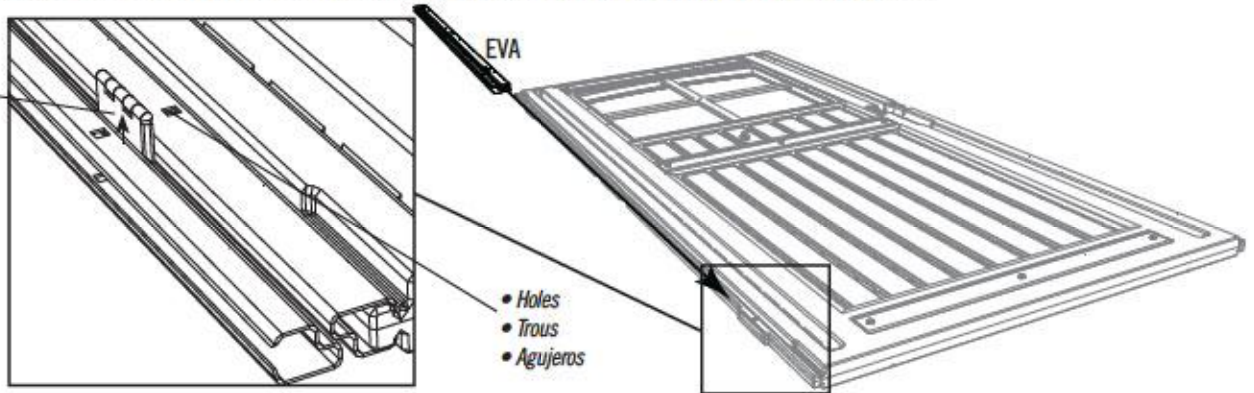

4.4

- Secure the Hinge to the Door using the required hardware. **Tighten securely.**
- Attacher la charnière à la porte gauche à l'aide de la quincaillerie indiquée. **Serrer bien la quincaillerie.**
- Sujetar la bisagra a la puerta usando el herraje indicado. **Apretar bien el herraje.**

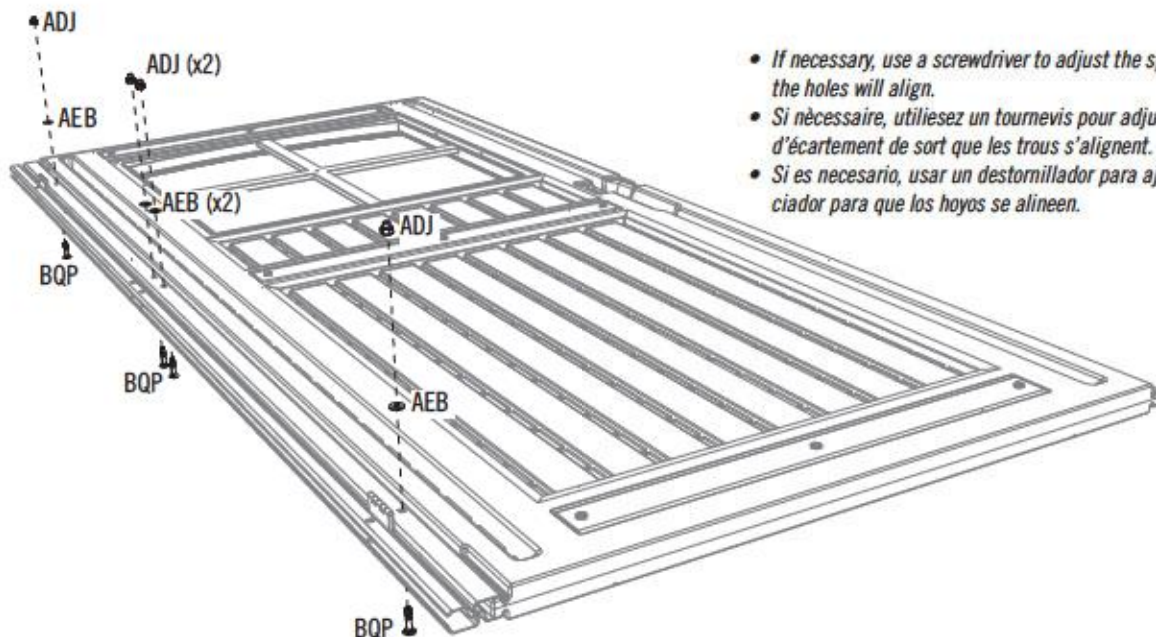

- If necessary, use a screwdriver to adjust the spacer so that the holes will align.
- Si nécessaire, utilisez un tournevis pour ajuster la pièce d'écartement de sorte que les trous s'alignent.
- Si es necesario, usar un destornillador para ajustar el espaciador para que los hoyos se alineen.

► SECTION 4 (CONTINUED) / SECCIÓN 4 (CONTINUACIÓN) / SECTION 4 (SUITE)

TOOLS AND HARDWARE REQUIRED / INSTRUMENTAL Y HERRAJE REQUERIDOS / OUTILS ET QUINCAILLERIE REQUIS

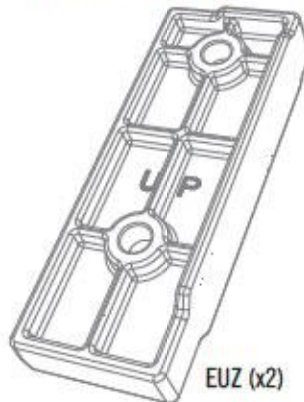

• There are two (2) Deadbolt Spacers (EUZ), but they are the same part. One side shows the word "UP" and the other side shows the word "DOWN". The side of the Spacer with the word "UP" should face you when attaching it to the **top end** of the Hinge (See Step 4.5). The side of the Spacer with the word "DOWN" should also face you when attaching it to the **bottom end** of the Hinge. Because of the direction the words are printed, the Spacers should point in opposite directions, but the words will still be right side up. The borders indicated below should fit flush against the borders of the Hinge.

• Il y a deux (2) pièces d'écartement (EUZ), mais ils sont la même pièce. Un côté affiche le mot « UP » (HAUT) pendant que l'autre côté affiche le mot « DOWN » (BAS). Le côté de la pièce d'écartement avec le mot « UP » doit faire face à vous lorsque vous l'attachez à l'**extrémité supérieure** de la charnière (voyez l'étape 4.5). Le côté de la pièce d'écartement avec le mot « DOWN » doit aussi faire face à vous lorsque vous l'attachez à l'**extrémité inférieure** de la charnière. En raison de la direction des mots imprimés, les pièces d'écartement doivent pointer en sens opposés, mais les mots devront être tête en haut. Les bords indiqués en bas doivent être au ras des bords de la charnière.

• Hay dos (2) espaciadores (EUZ), mas ellos son la misma pieza. Un lado muestra la palabra «UP» (PARA ARRIBA) mientras que el otro muestra la palabra «DOWN» (PARA ABAJO). El lado del espaciador con la palabra «UP» debe mirar hacia usted al sujetarlo al **extremo superior** de la bisagra (vea el paso 4.5). El lado del espaciador con la palabra «DOWN» también debe mirar hacia usted al sujetarlo al **extremo inferior** de la bisagra. Debida a la dirección de las palabras imprimidas, los espaciadores deben estar orientados en direcciones opuestas, mas las palabras estarán de cabeza arriba. Los bordes indicados abajo deben encajarse bien contra los bordes de la bisagra.

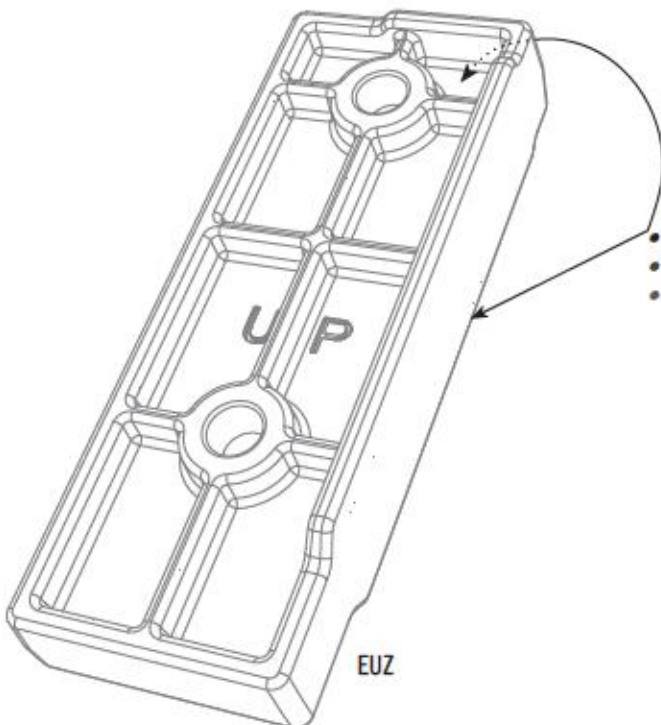

- Borders
- Bords
- Bordes

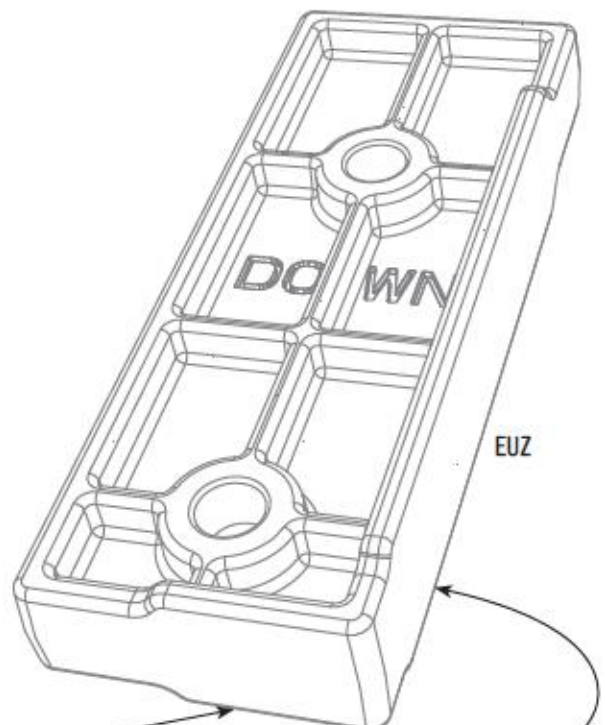

- Borders
- Bords
- Bordes

► SECTION 4 (CONTINUED) / SECCIÓN 4 (CONTINUACIÓN) / SECTION 4 (SUITE)

TOOLS AND HARDWARE REQUIRED / INSTRUMENTAL Y HERRAJE REQUERIDOS / OUTILS ET QUINCAILLERIE REQUIS

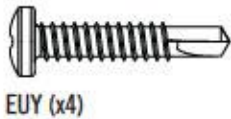

EUY (x4)

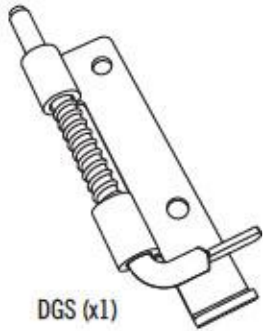

DGS (x1)

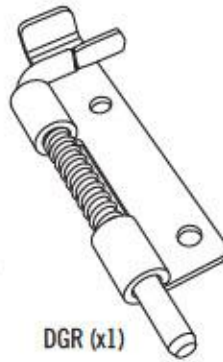

DGR (x1)

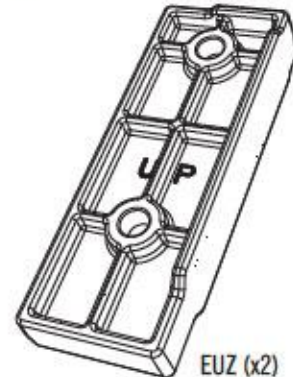

EUZ (x2)

4.5

- Use a drill to secure the **Deadbolts (DGR & DGS)** and **Spacers (EUZ)** to the Hinge and Left Door in the directions shown.
- Employer un perceuse électrique pour attacher bien les **verrous (DGR et DGS)** et les **pièces d'écartement (EUZ)** à la charnière et la porte gauche **dans les directions indiquées.**
- Usar un taladro eléctrico para sujetar bien los **cerrojos (DGR y DGS)** y los **espaciadores (EUZ)** a la bisagra y la puerta izquierda **en las direcciones indicadas.**

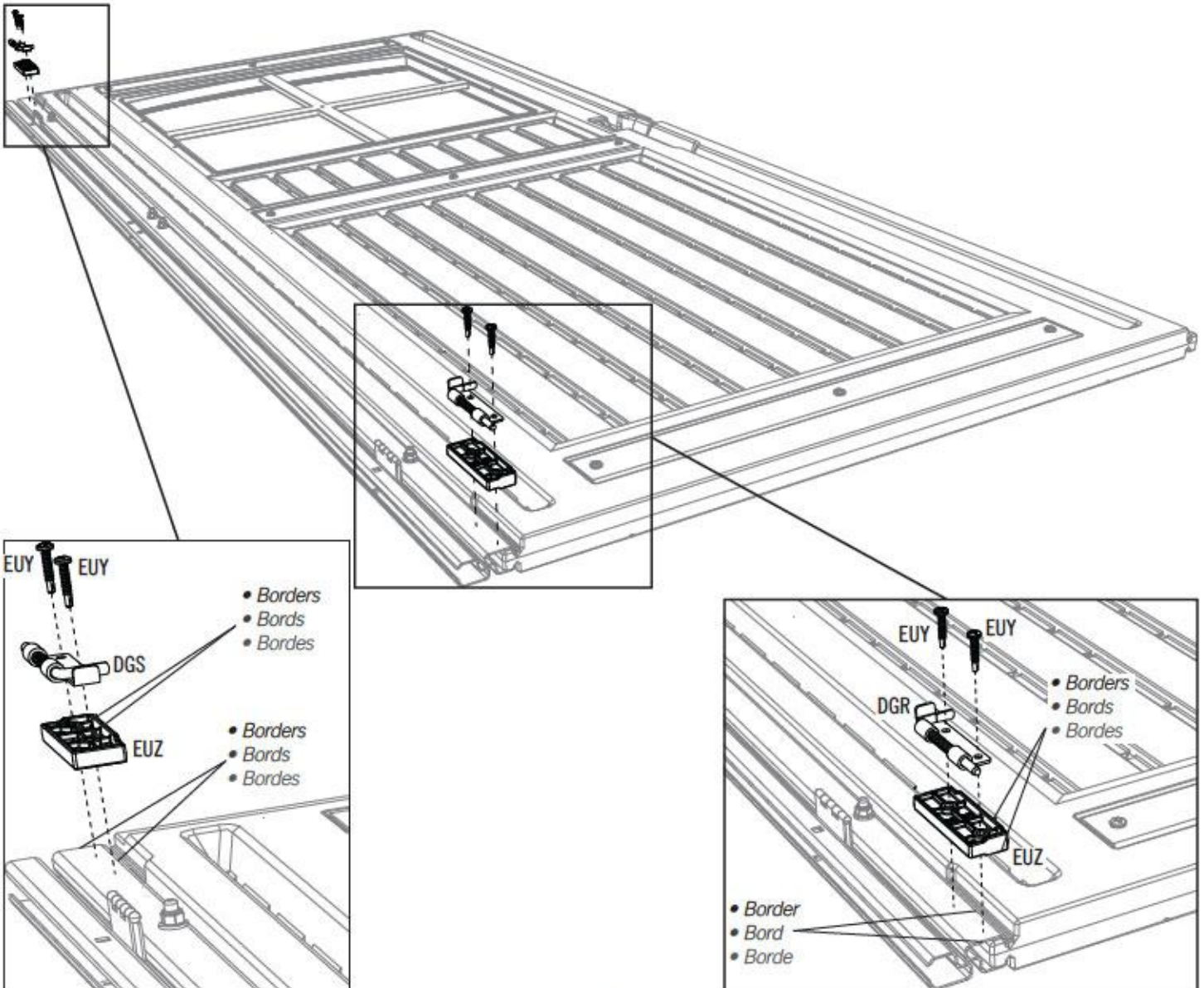

5

RIGHT DOOR ASSEMBLY / ASSEMBLAGE DE LA PORTE DROITE / ENSAMBLE DE LA PUERTA DERECHA



HARDWARE REQUIRED / QUINCAILLERIE REQUISE / HERRAJE REQUERIDO

Hardware Bags / Sacs de quincaillerie / Bolsas de herraje

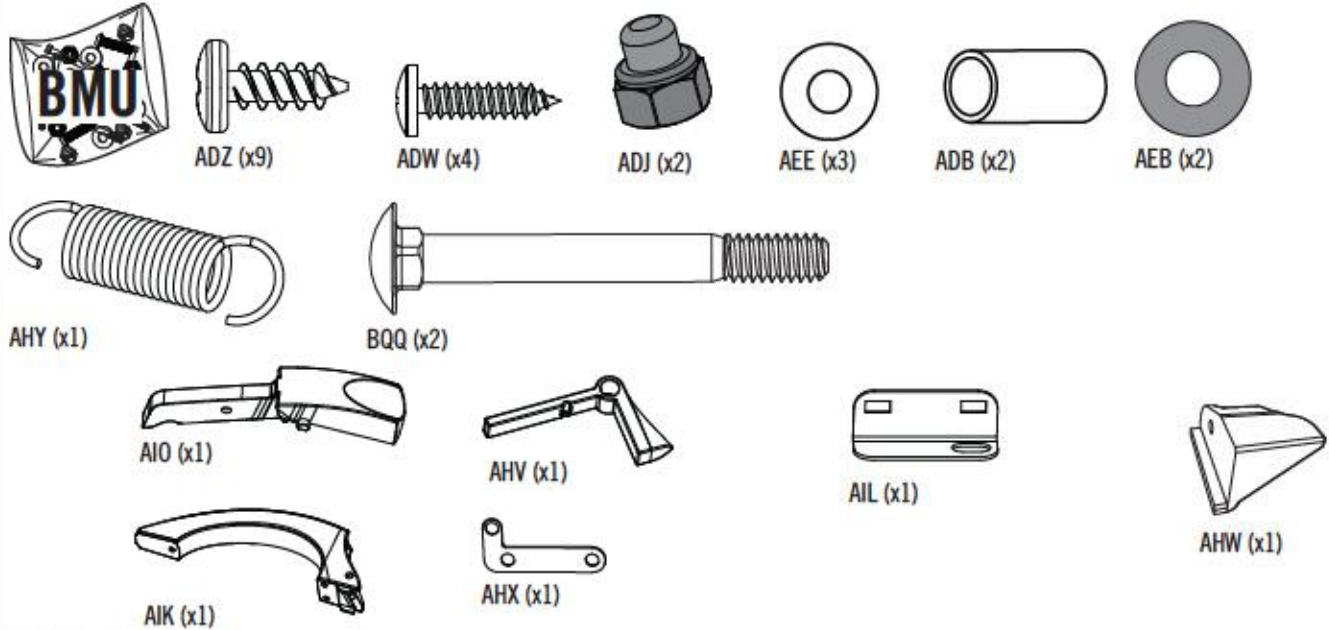

PARTS REQUIRED / PIÈCES REQUISES / PIEZAS REQUERIDAS

Metal Parts / Pièces en métal / Piezas de metal

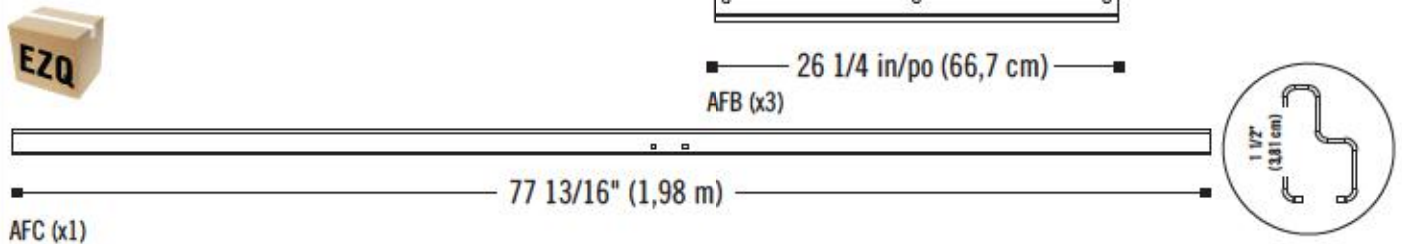

Plastic Parts / Pièces en plastique / Piezas de plástico

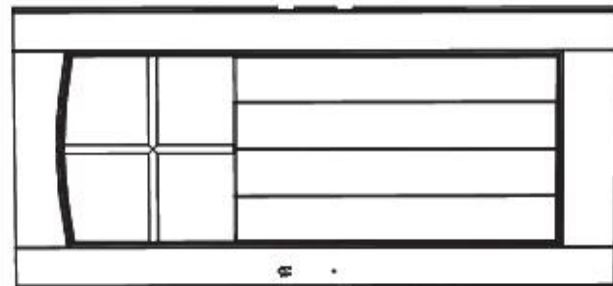

AGZ (x1)



TOOLS REQUIRED / OUTILS REQUIS / INSTRUMENTAL REQUERIDO



► SECTION 5 (CONTINUED) / SECTION 5 (SUITE) / SECCIÓN 5 (CONTINUACIÓN)

TOOLS AND HARDWARE REQUIRED / OUTILS ET QUINCAILLERIE REQUIS / INSTRUMENTAL Y HERRAJE REQUERIDOS

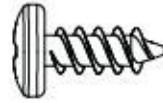

ADZ (9)

5.1

- Attach three (3) **Metal Braces (AFB)** to the back of the **Right Door (AGZ)**.
- Attacher trois (3) **supports en métal (AFB)** au côté arrière de la **porte droite (AGZ)**.
- Sujetar tres (3) **soportes de metal (AFB)** a la cara trasera de la **puerta derecha (AGZ)**.

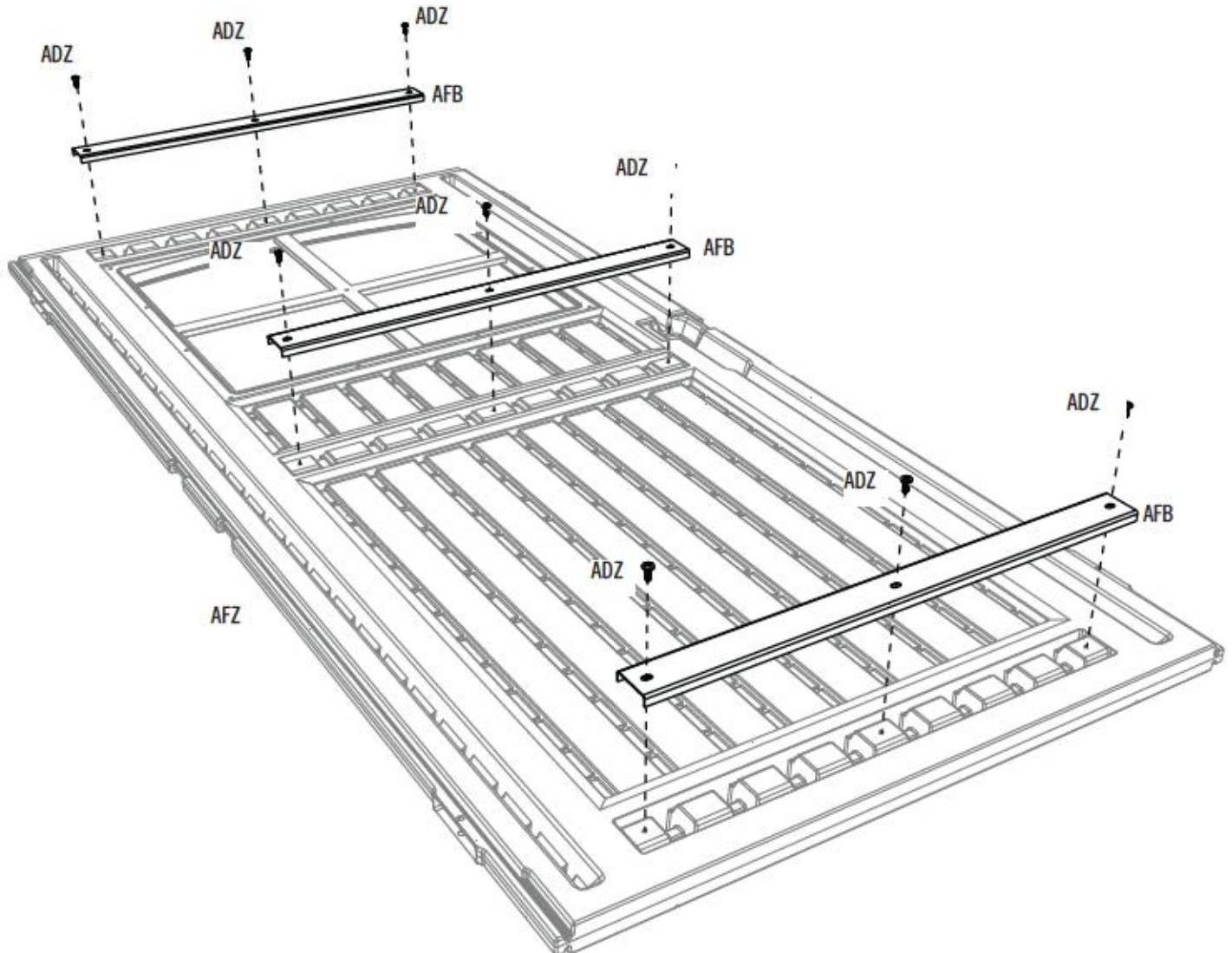

► SECTION 5 (CONTINUED) / SECTION 5 (SUITE) / SECCIÓN 5 (CONTINUACIÓN)

TOOLS AND HARDWARE REQUIRED / OUTILS ET QUINCAILLERIE REQUIS / INSTRUMENTAL Y HERRAJE REQUERIDOS

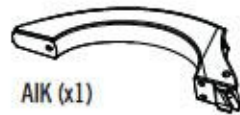

AIK (x1)

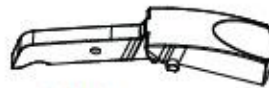

AIO (x1)



• **Door Channels (AFC)** are bowed by design, ensuring a tight fit when they are closed and latched, making your shed more secure. These channels are formed with a slight bend to the adjoining door edge—like parentheses facing each other: (). When the door handle is gently closed and latched, there should be a slight pressure sealing the doors and eliminating any gaps. Be sure to read the step-by-step instructions carefully to successfully install the door channels.

• **Les canaux pour le bord des portes (AFC)** sont courbés par design, en s'assurant un ajustage lorsque les portes se ferment, en faisant votre abri plus sûr. Ces canaux sont fabriqués avec une légère courbe au bord de la porte adjacent — comme les parenthèses qui font face l'une l'autre : (). Lorsque la poignée se ferme, il devrait un légère pression en rebouchant les portes et en éliminant des ouvertures. Assurez-vous de lire avec soin les instructions étape par étape pour pouvoir installer avec succès les canaux pour le bord des portes.

• **Los canales para el borde de las puertas (AFC)** son curvados por diseño, asegurando un ajuste fijo cuando las puertas estén cerrados con pestillo, haciendo su caseta más segura. Estos canales están formados con una curva ligera al borde de la puerta adyacente, como los paréntesis uno enfrente al otro: (). Cuando el picaporte esté ligeramente cerrado con pestillo, debería tener una presión ligera sellando las puertas y eliminando los espacios. Asegúrese de leer detenidamente las instrucciones paso a paso para poder instalar exitosamente los canales para el borde de las puertas.



5.2

AFC

• Slide the **Door Edge Channel (AFC)** over the edge of the Door until flush with the bottom border of the Door.

• Faire glisser le **canal pour le bord de la porte (AFC)** sur le bord de la porte jusqu'à ce qu'il soit au ras du bord inférieure de la porte.

• Deslizar el **canal para el borde de la puerta (AFC)** sobre el borde de la puerta hasta que esté a ras del borde inferior de la puerta.

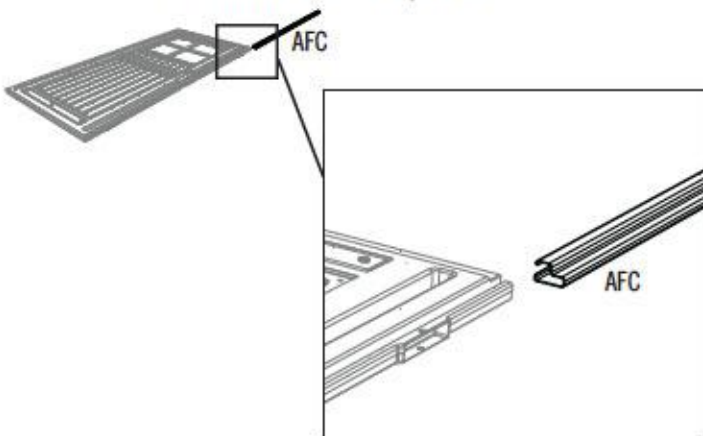

5.3

• Slide the **Thumb Lever (AIO)** down into the grooves in the **Door Handle (AIK)** until the nubs fit into the holes.

• Faire glisser le **levier poussoir (AIO)** dans les rainures de la **poignée (AIK)** jusqu'à ce que les petites bosses se fixent dans les trous.

• Deslizar la **palanca de pulgar (AIO)** en las ranuras del **picaporte (AIK)** hasta que los nudos se encajen en los agujeros.

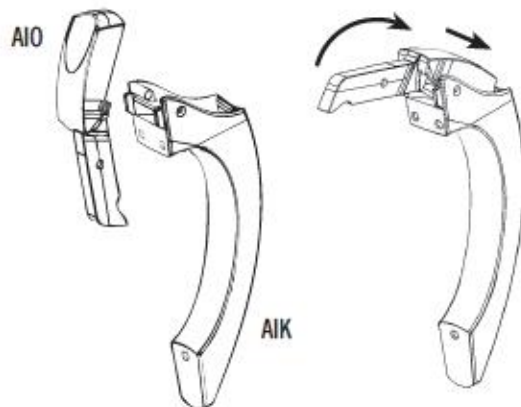

► SECTION 5 (CONTINUED) / SECTION 5 (SUITE) / SECCIÓN 5 (CONTINUACIÓN)

TOOLS AND HARDWARE REQUIRED / OUTILS ET QUINCAILLERIE REQUIS / INSTRUMENTAL Y HERRAJE REQUERIDOS

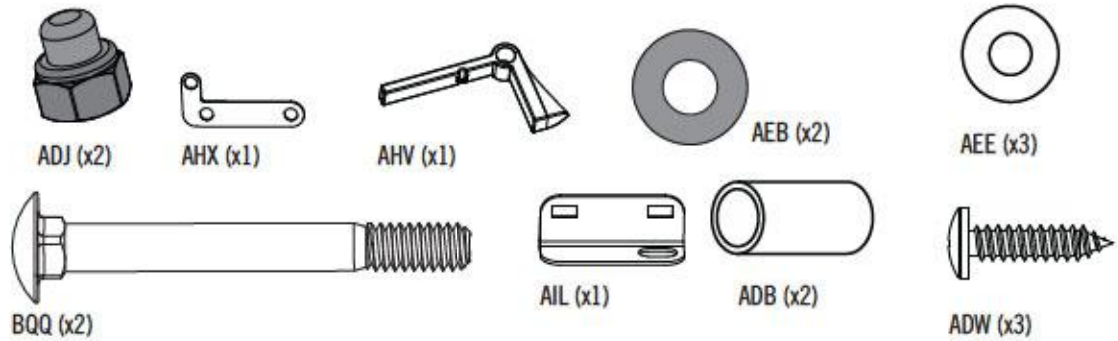

5.4

- Insert the Thumb Lever through the slot, and attach the Handle using the hardware provided.
- Insérer le levier poussoir à travers la fente, et attacher la poignée à l'aide des accessoires fournis.
- Insertar la palanca de pulgar a través de la ranura, y sujetar el picaporte usando el herraje incluido.

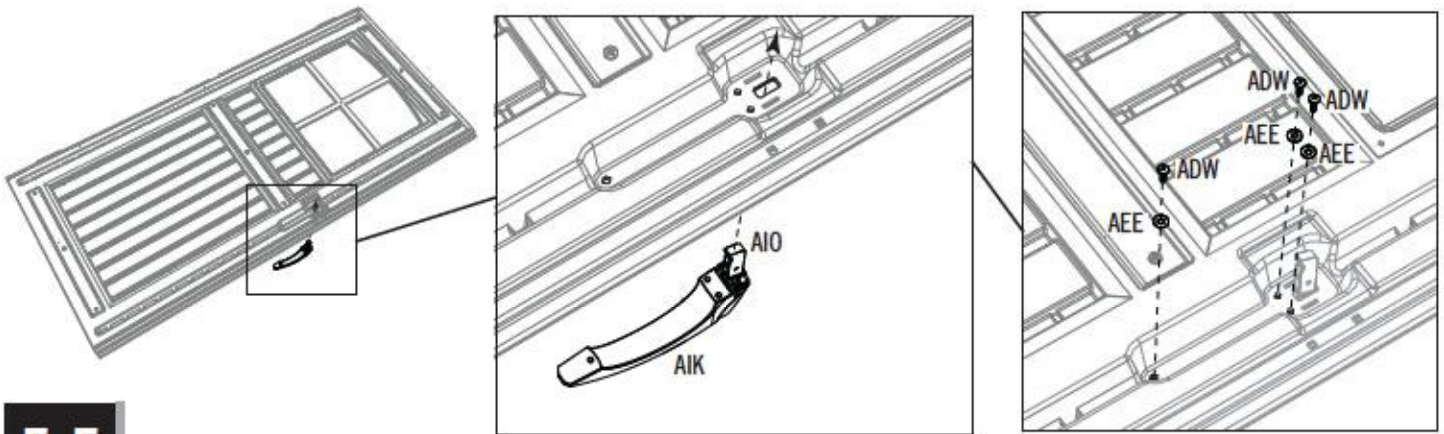

5.5

- Attach the Locking Hardware using the hardware provided. **The arm of the Latch rests on top of the Thumb Lever.**
- Attacher les accessoires de verrouillage à l'aide de la quincaillerie indiquée. **Le bras du loquet doit rester sur le levier poussoir.**
- Sujetar los accesorios de cierre usando el herraje incluido. **El brazo del pestillo se queda sobre la palanca de pulgar.**

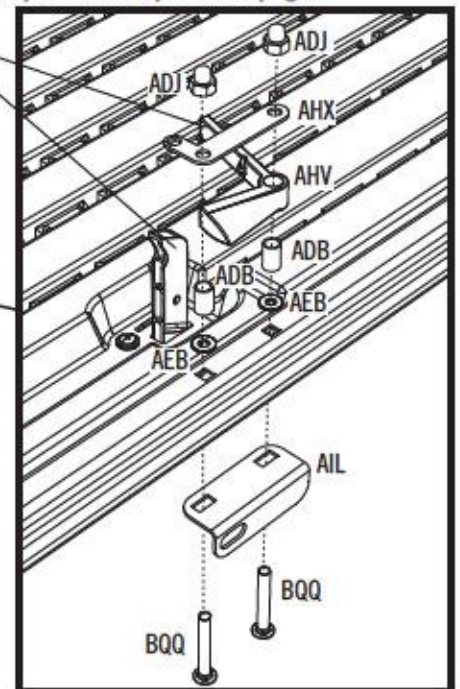
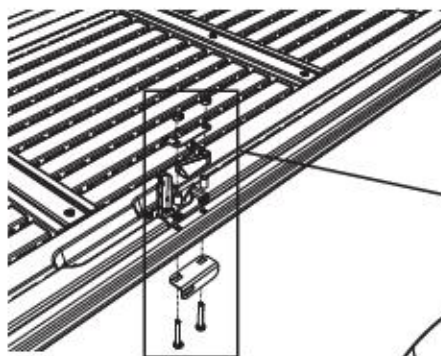

- **The arm of the Latch rests on top of the Thumb Lever.**
- **El brazo del pestillo se queda sobre la palanca de pulgar.**
- **Le bras du loquet doit rester sur le Levier poussoir.**

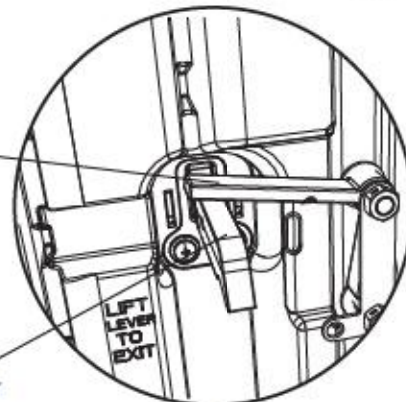

Thumb Lever / Levier poussoir / palanca de pulgar

► SECTION 5 (CONTINUED) / SECTION 5 (SUITE) / SECCIÓN 5 (CONTINUACIÓN)

TOOLS AND HARDWARE REQUIRED / OUTILS ET QUINCAILLERIE REQUIS / INSTRUMENTAL Y HERRAJE REQUERIDOS



ADW (x1)



AHW (x1)

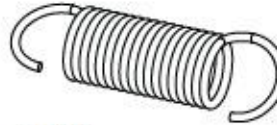

AHY (x1)

5.6

- Attach the **Thumb Lever Support (AHW)** to the **Thumb Lever (AIO)** using a **Screw (ADW)**. The edge of the Support goes underneath the Thumb Lever.
- Attacher le **support du levier poussoir (AHW)** au **levier poussoir (AIO)** à l'aide d'une **vis (ADW)**. Le bord du support se fixe sous le levier poussoir.
- Sujetar el soporte de la palanca de pulgar (AHW) a la palanca de pulgar (AIO) usando un tornillo (ADW). El borde del soporte se fija debajo la palanca de pulgar.

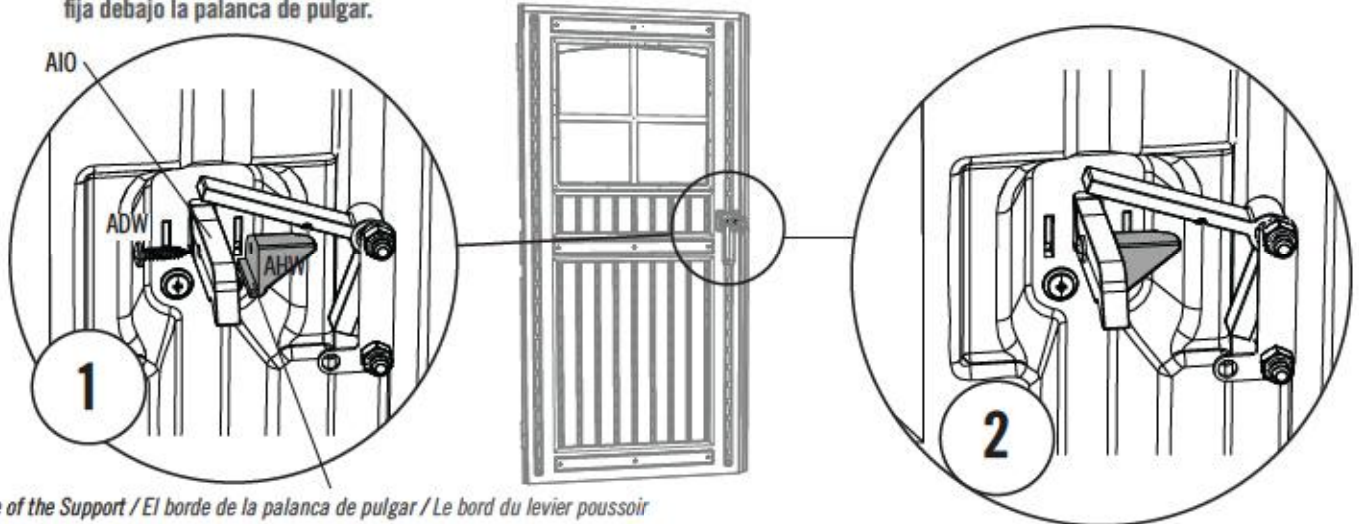

The Edge of the Support / El borde de la palanca de pulgar / Le bord du levier poussoir

5.7

- Attach the **Spring (AHY)** to the **Latch (AHV)** and **Latch Cover Plate (AHX)** as shown.
- Attacher le **ressort (AHY)** au **loquet (AHV)** et la **plaque protectrice du loquet (AHX)** comme illustré.
- Sujetar el resorte (AHY) al pestillo (AHV) y a la placa cubrepestillo (AHX) como se muestra.

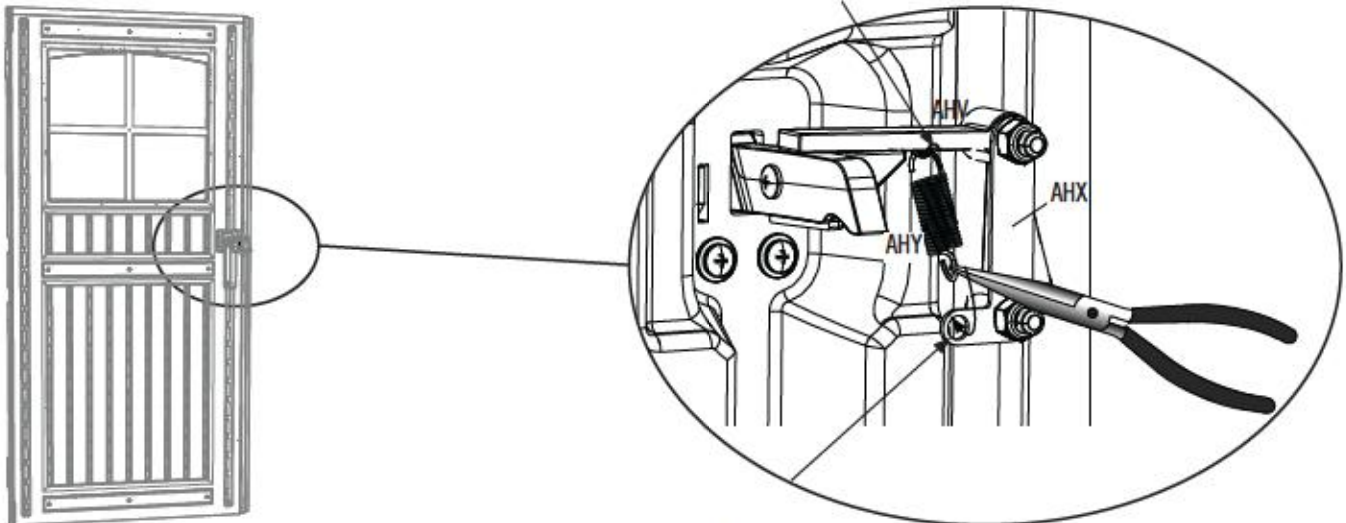

6

CENTER DOOR ASSEMBLY / ENSAMBLE DE LA PUERTA CENTRAL / ASSEMBLAGE DE LA PORTE CENTRALE



HARDWARE REQUIRED / HERRAJE REQUERIDO / QUINCAILLERIE REQUISE

Hardware Bag / Bolsa de herraje / Sac de quincaillerie

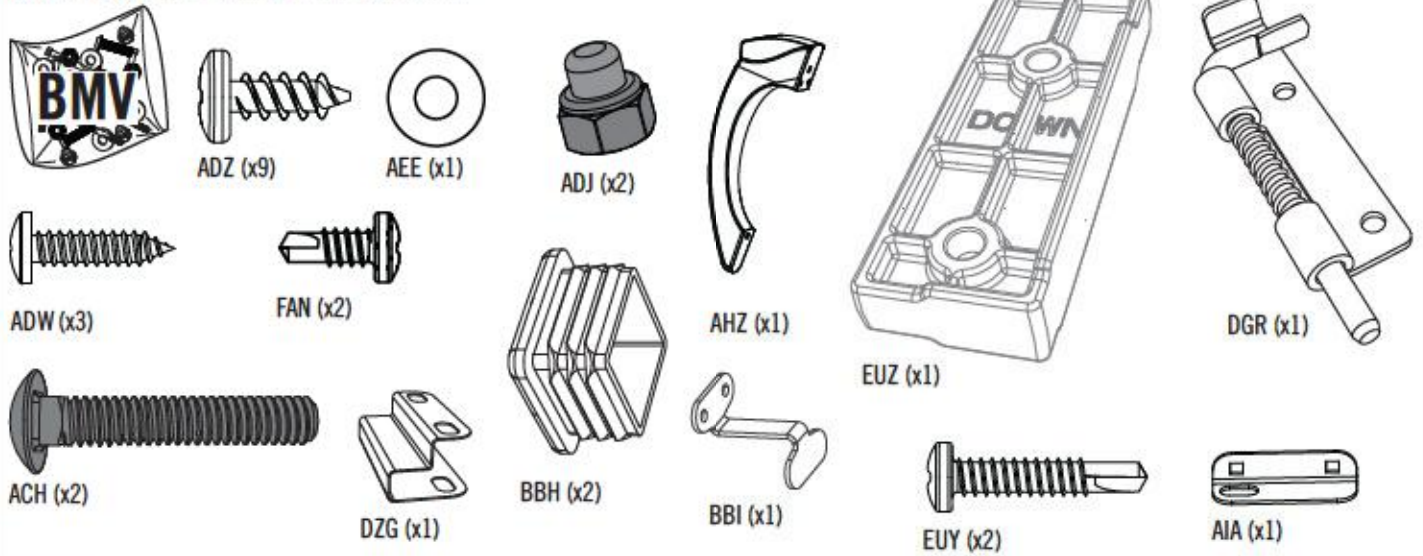

PARTS REQUIRED / PIEZAS REQUERIDAS / PIÈCES REQUISES

Metal Parts / Piezas de metal / Pièces en métal

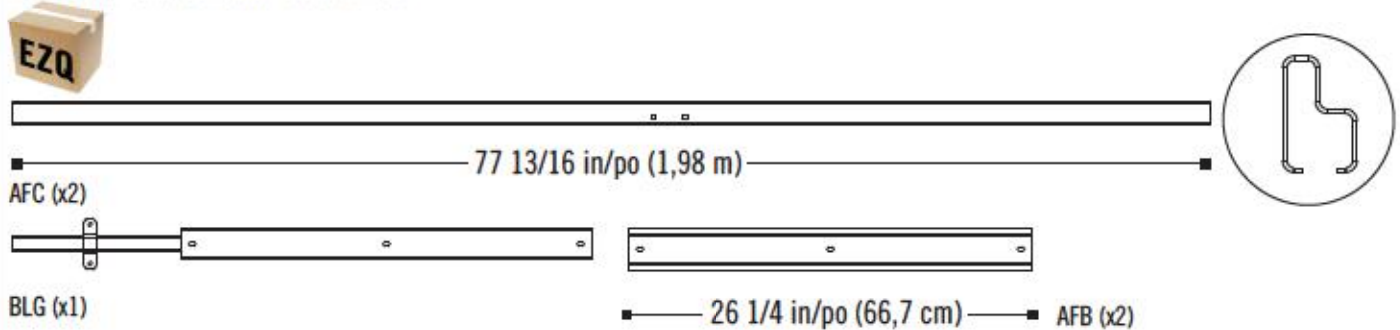

Plastic Parts / Piezas de plástico / Pièces en plastique

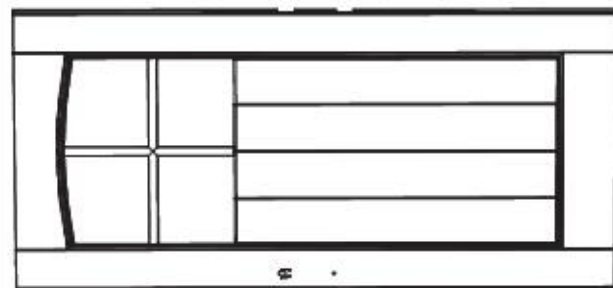

AGZ (x1)



TOOLS REQUIRED / INSTRUMENTAL REQUERIDO / OUTILS REQUIS



► SECTION 6 (CONTINUED) / SECCIÓN 6 (CONTINUACIÓN) / SECTION 6 (SUITE)

TOOLS AND HARDWARE REQUIRED / INSTRUMENTAL Y HERRAJE REQUERIDOS / OUTILS ET QUINCAILLERIE REQUIS



.....

- *Door Channels (AFC) are bowed by design, ensuring a tight fit when they are closed and latched, making your shed more secure. These channels are formed with a slight bend to the adjoining door edge—like parentheses facing each other: (). When the door handle is gently closed and latched, there should be a slight pressure sealing the doors and eliminating any gaps. Be sure to read the step-by-step instructions carefully to successfully install the door channels.*

- *Les canaux pour le bord des portes (AFC) sont courbés par dessein, en s'assurant un ajustage lorsque les portes se ferment, en faisant votre abri plus sûr. Ces canaux sont fabriqués avec une légère courbe au bord de la porte adjacent — comme les parenthèses qui font face l'une l'autre : (). Lorsque la poignée se ferme, il devrait un légère pression en rebouchant les portes et en éliminant des ouvertures. Assurez-vous de lire avec soin les instructions étape par étape pour pouvoir installer avec succès les canaux pour le bord des portes.*

- *Los canales para el borde de las puertas (AFC) son curvados por diseño, asegurando un ajuste fijo cuando las puertas estén cerrados con pestillo, haciendo su caseta más segura. Estos canales están formados con una curva ligera al borde de la puerta adyacente, como los paréntesis uno enfrente al otro: (). Cuando el picaporte esté ligeramente cerrado con pestillo, debería tener una presión ligera sellando las puertas y eliminando los espacios. Asegúrese de leer detenidamente las instrucciones paso a paso para poder instalar exitosamente los canales para el borde de las puertas.*



AFC

► SECTION 6 (CONTINUED) / SECCIÓN 6 (CONTINUACIÓN) / SECTION 6 (SUITE)

TOOLS AND HARDWARE REQUIRED / INSTRUMENTAL Y HERRAJE REQUERIDOS / OUTILS ET QUINCAILLERIE REQUIS



7/16 in/po
(11 mm)



ACH (x2)



ADJ (x2)

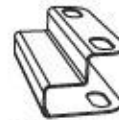

DZG (x1)



AIA (x1)

6.1

- Orient the **Door Edge Channel (AFC)** as shown, and slide it over the edge of the **Center Door (AGZ)** until it's flush with the bottom of the Center Door.
- Orienter le canal pour le bord de la porte (AFC) comme illustré, et faire glisser sur le bord de la porte centrale (AGZ) jusqu'à ce qu'il soit au ras du bord inférieur de la porte.
- Orientar el canal para el borde de la puerta (AFC) como se muestra, y deslizarlo sobre el borde de la puerta central (AGZ) hasta que esté a ras del borde inferior de la puerta.

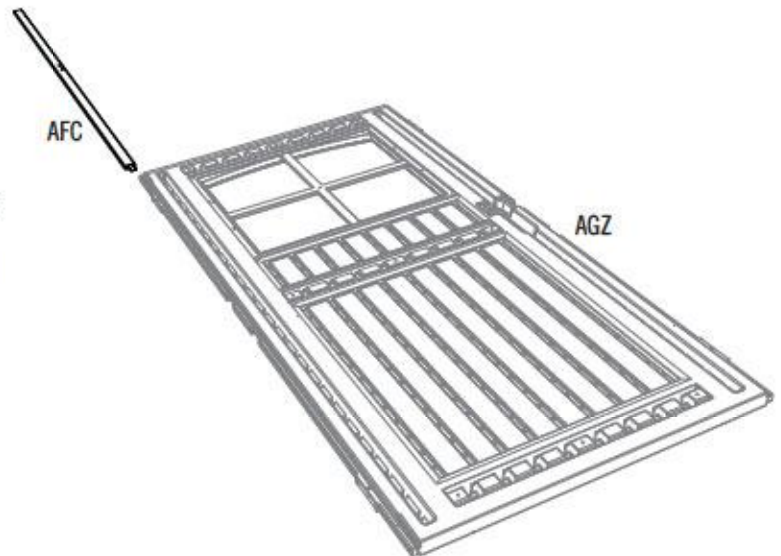

6.2

- Slide the **Center Door Strike Plate (DZG)** over the Door Edge Channel as shown, and align the holes in the Strike Plate with those in the Channel. Secure the **Center Door Latch (AIA)** to the Door using the hardware included. **Do not overtighten.**
- Faire glisser la gâche de la porte centrale (DZG) sur le canal pour le bord de la porte centrale comme illustré, et aligner les trous dans la gâche avec ceux du canal. Attacher bien le loquet central (AIA) à la porte à l'aide de la quincaillerie incluse. **Ne pas trop serrer.**
- Orientar la placa de impacto de la puerta central (DZG) sobre el canal para el borde de la puerta central como se muestra, y alinear los agujeros en la placa con ellos en el canal. Sujetar el pestillo de cierre central (AIA) a la puerta usando el herraje incluido. **No apretar demasiado.**

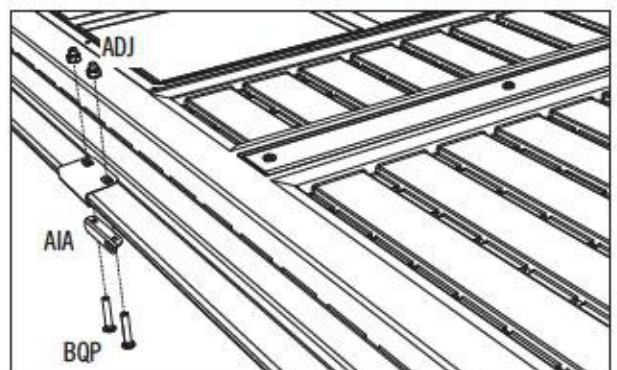
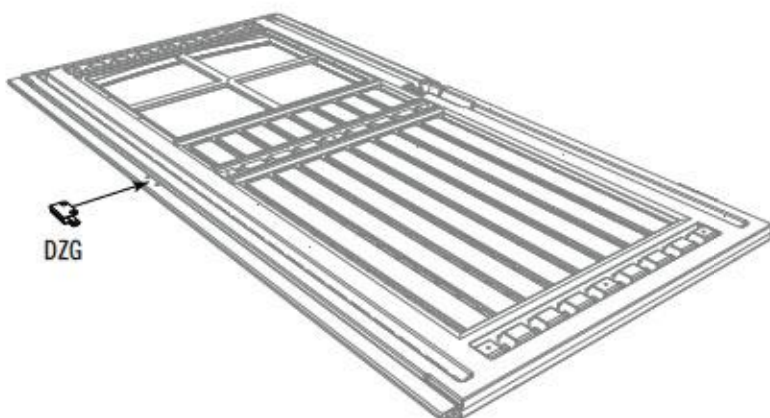

► SECTION 6 (CONTINUED) / SECCIÓN 6 (CONTINUACIÓN) / SECTION 6 (SUITE)

TOOLS AND HARDWARE REQUIRED / INSTRUMENTAL Y HERRAJE REQUERIDOS / OUTILS ET QUINCAILLERIE REQUIS

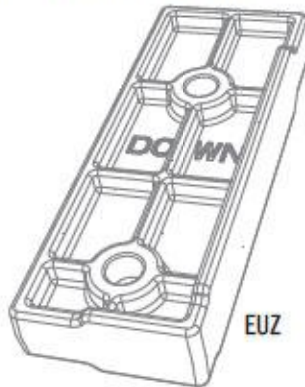

• There are two (2) Deadbolt Spacers (EUZ), but they are the same part. One side shows the word "UP" and the other side shows the word "DOWN". The side of the Spacer with the word "DOWN" should also face you when attaching it to the **bottom end** of the Door Edge Channel (See Step 6.3). Because of the direction the words are printed, the word "DOWN" will be right side up when installed correctly. The borders indicated below should fit flush against the borders of the lower end of the Door Edge Channel.

• Il y a deux (2) pièces d'écartement (EUZ), mais ils sont la même pièce. Un côté affiche le mot « UP » (HAUT) pendant que l'autre côté affiche le mot « DOWN » (BAS). Le côté de la pièce d'écartement avec le mot « DOWN » doit aussi faire face à vous lorsque vous l'attachez à l'**extrémité inférieure** du canal pour le bord de la porte (voyez l'étape 6.3). En raison de la direction des mots imprimés, le mot « DOWN » devrait être attaché tête en haut. Les bords indiqués en bas doivent être au ras des bords de la extrémité inférieure du canal pour le bord de la porte.

• Hay dos (2) espaciadores (EUZ), mas ellos son la misma pieza. Un lado muestra la palabra «UP» (PARA ARRIBA) mientras que el otro muestra la palabra «DOWN» (PARA ABAJO). El lado del espaciador con la palabra «DOWN» debe mirar hacia usted al sujetarlo al **extremo inferior** del canal para el borde de la puerta (vea el paso 6.3). Debida a la dirección de las palabras imprimidas, la palabra «DOWN» estará de cabeza arriba. Los bordes indicados abajo deben encajarse bien contra los bordes del extremo inferior del canal para el borde de la puerta.

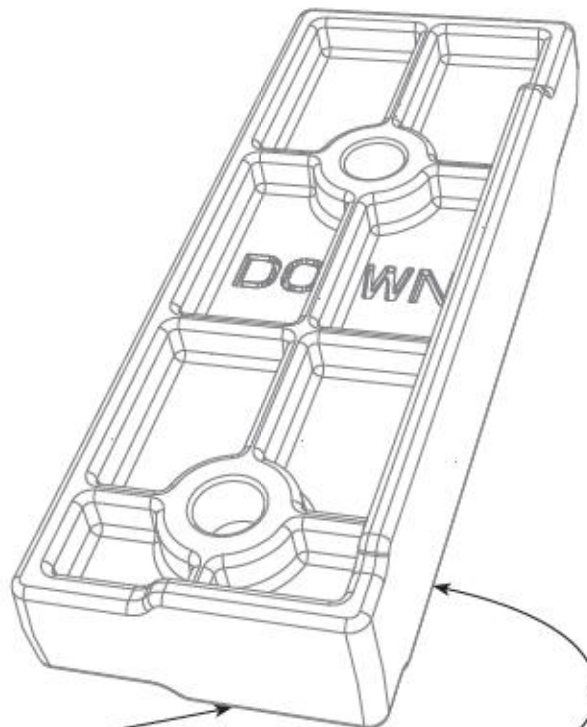

- Borders
- Bords
- Bordes

► SECTION 6 (CONTINUED) / SECCIÓN 6 (CONTINUACIÓN) / SECTION 6 (SUITE)

TOOLS AND HARDWARE REQUIRED / INSTRUMENTAL Y HERRAJE REQUERIDOS / OUTILS ET QUINCAILLERIE REQUIS

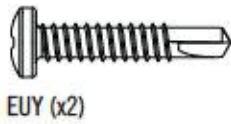

EUY (x2)

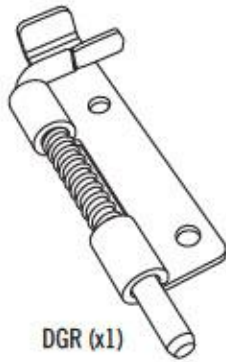

DGR (x1)

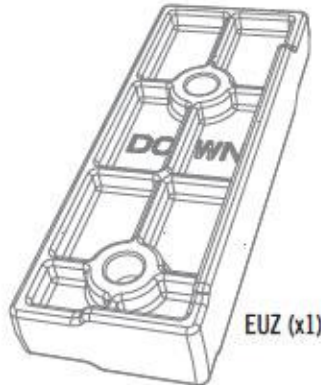

EUZ (x1)

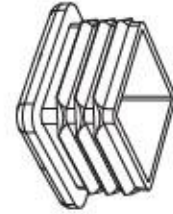

BBH (x2)

6.3

- Use an electric drill to secure the **Deadbolt (DGR)** and **Spacer (EUZ)** to the Door Edge Channel and Center Door **in the direction shown**.
- Employer un perceuse électrique pour attacher bien le **verrou (DGR)** et la **pièce d'écartement (EUZ)** au canal pour le bord de la porte et à la porte centrale **dans les directions indiquées**.
- Usar un taladre eléctrico para sujetar bien el **cerrojo (DGR)** y el **espaciador (EUZ)** al canal para el borde de la puerta y a la puerta central **en las direcciones indicadas**.

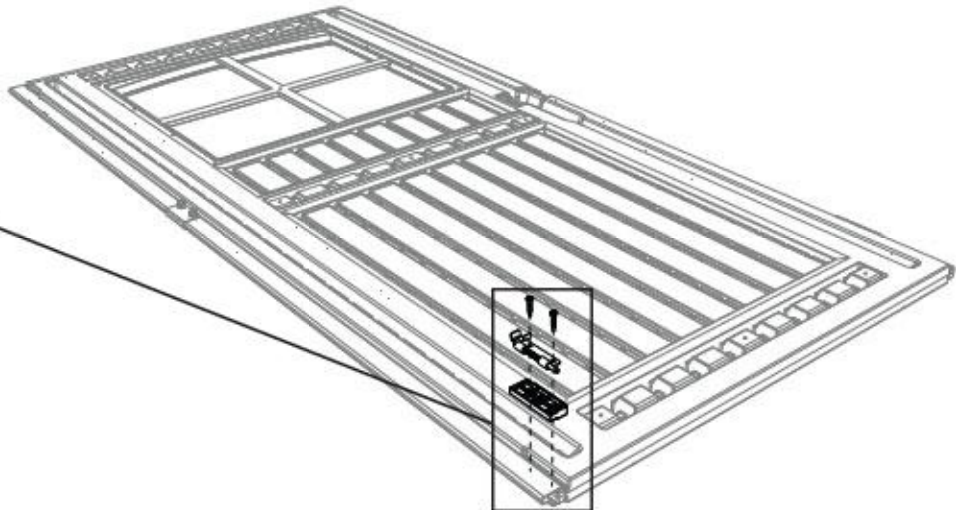
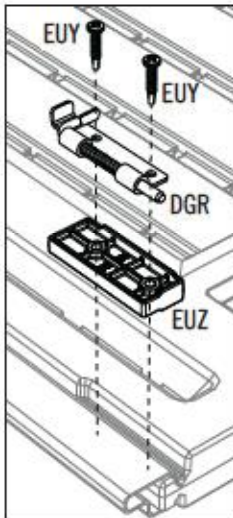

6.4

- Insert **End Caps (BBH)** into the ends of the **Upper Metal Brace (BLG)**.
- Insérer les **capuchons (AFB)** dans les extrémités du **support supérieur en métal (BLG)**.
- Insertar los **tapones (BBH)** en los extremos del **soporte superior de metal (BLG)**.

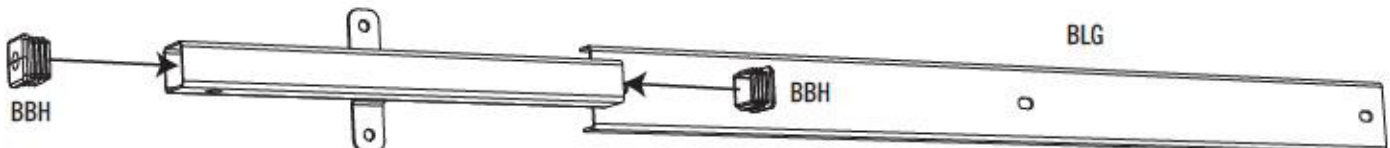

► SECTION 6 (CONTINUED) / SECCIÓN 6 (CONTINUACIÓN) / SECTION 6 (SUITE)

TOOLS AND HARDWARE REQUIRED / INSTRUMENTAL Y HERRAJE REQUERIDOS / OUTILS ET QUINCAILLERIE REQUIS

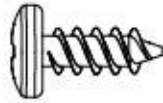

ADZ (x9)

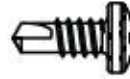

FAN (x2)

6.5

- Attach three (3) **Metal Braces (BLG & AFB)** to the back of the **Center Door (AGZ)** using three (3) **Screws (ADZ)** for each Brace.
- Attacher trois (3) **supports en métal (BLG et AFB)** au côté arrière de la **porte centrale (AGZ)** à l'aide de trois (3) **vis (ADZ)** pour chaque support.
- Sujetar tres (3) **soportes de metal (BLG y AFB)** a la cara trasera de la **puerta central (AGZ)** usando tres (3) **tornillos (ADZ)** para cada soporte.

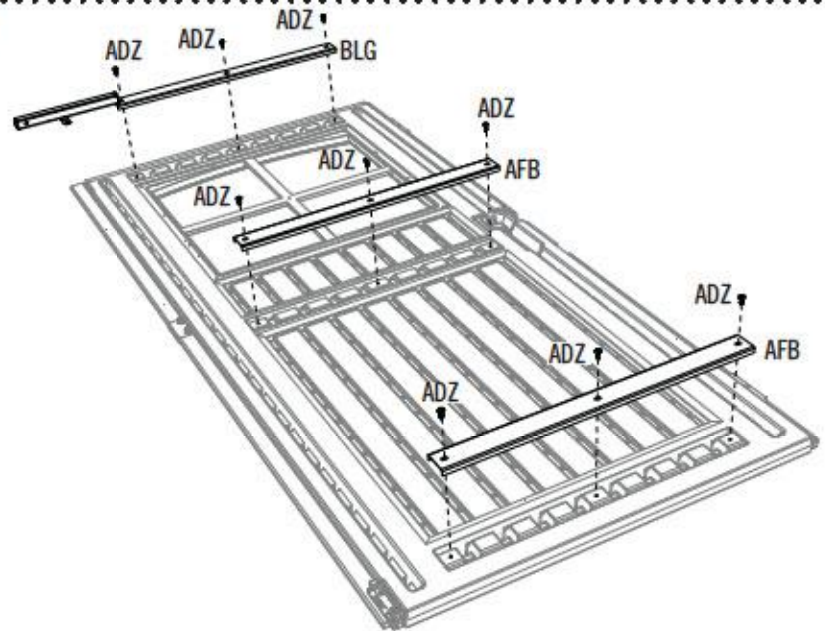

6.6

- Attach the left end of the **Upper Metal Support** to the Door using two (2) **Screws (FAN)**.
- Attacher l'extrémité gauche du **support supérieur en métal** à la porte à l'aide de deux (2) **vis (FAN)**.
- Sujetar el extremo izquierdo del **soporte superior de metal** a la puerta usando dos (2) **tornillos (FAN)**.

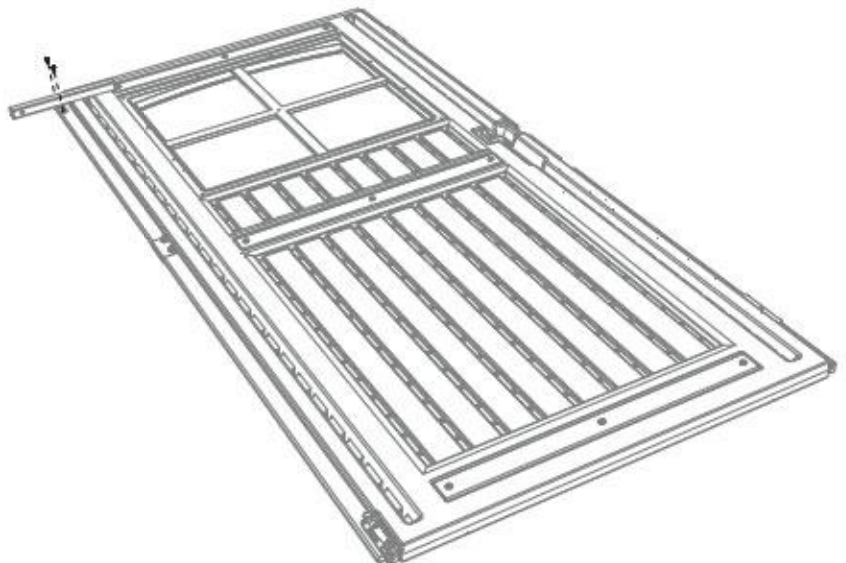
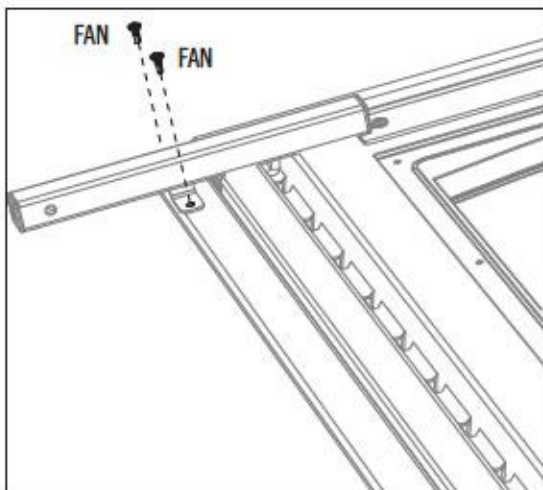

► SECTION 6 (CONTINUED) / SECCIÓN 6 (CONTINUACIÓN) / SECTION 6 (SUITE)

TOOLS AND HARDWARE REQUIRED / INSTRUMENTAL Y HERRAJE REQUERIDOS / OUTILS ET QUINCAILLERIE REQUIS



AHZ (x1)

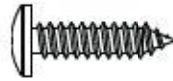

ADW (x3)



AEE (x1)

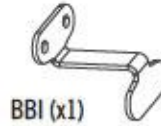

BBI (x1)

6.7

- Attach the **Handles (AHZ & BBI)** to the Door using the required hardware.
- Attacher les **poignées (AHZ et BBI)** à la porte à l'aide de la quincaillerie requise.
- Sujetar los **picaportes (AHZ y BBI)** a la puerta usando el herraje requerido.

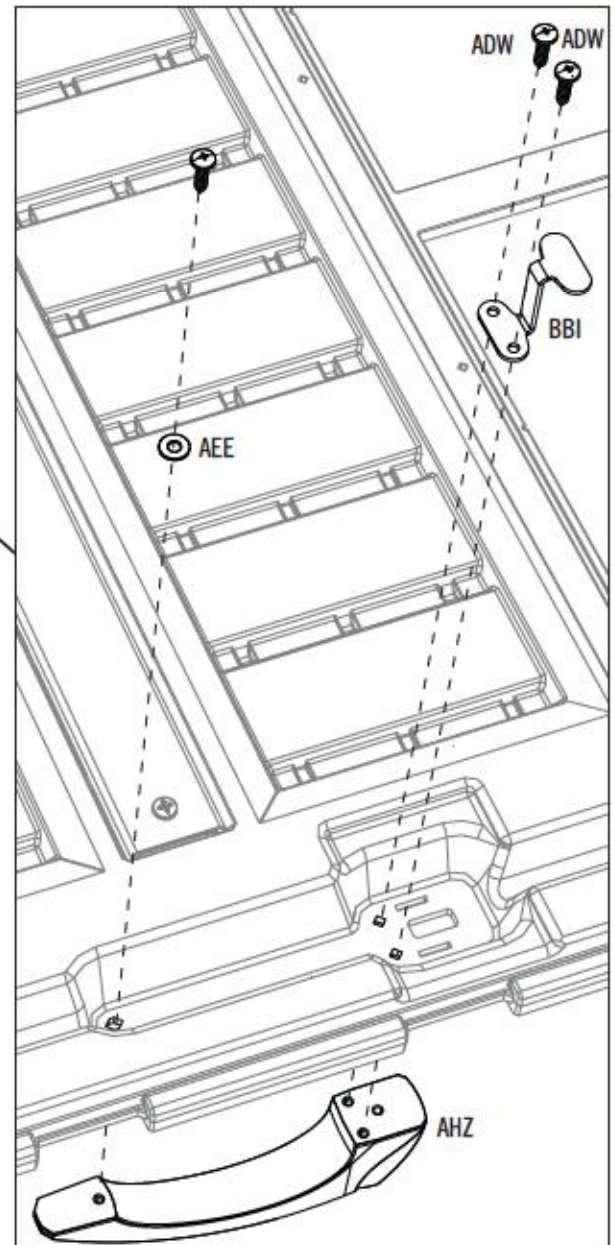
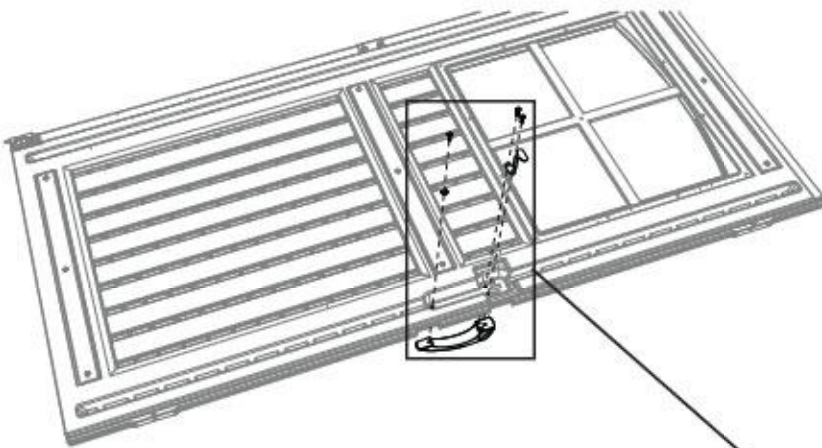

7

DOMED SKYLIGHT ASSEMBLY / ASSEMBLAGE DES LUCARNES EN FORME DE DÔME / ENSAMBLE DE LOS TRAGALUCES EN FORMA DE CÚPULA



HARDWARE REQUIRED / QUINCAILLERIE REQUISE / HERRAJE REQUERIDO

Hardware Bags / Sacs de quincaillerie / Bolsas de herraje



EFA (x24)



ADK (x24)



AEE (x48)



AHI (x2)



PARTS REQUIRED / PIÈCES REQUISES / PIEZAS REQUERIDAS

Plastic Parts / Pièces en plastique / Piezas de plástico

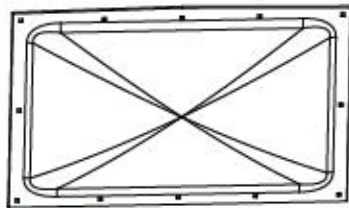

AGB (x2)

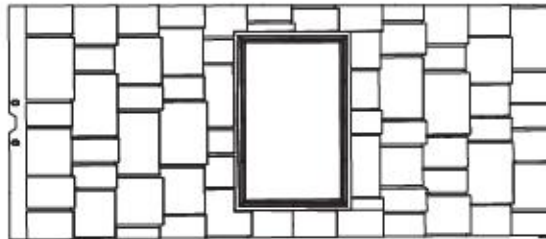

AHB (x2)



TOOLS REQUIRED / OUTILS REQUIS / INSTRUMENTAL REQUERIDO



3/8 in/po (10 mm)



► SECTION 7 (CONTINUED) / SECTION 7 (SUITE) / SECCIÓN 7 (CONTINUACIÓN)

TOOLS AND HARDWARE REQUIRED / OUTILS ET QUINCAILLERIE REQUIS / INSTRUMENTAL Y HERRAJE REQUERIDOS



AHI (x2)

7.1

- Remove any excess plastic from the holes along the opening.
- Enlever de l'excès de plastique des trous le long de l'ouverture.
- Retirar cualquier plástico en exceso de los agujeros a lo largo de la abertura.

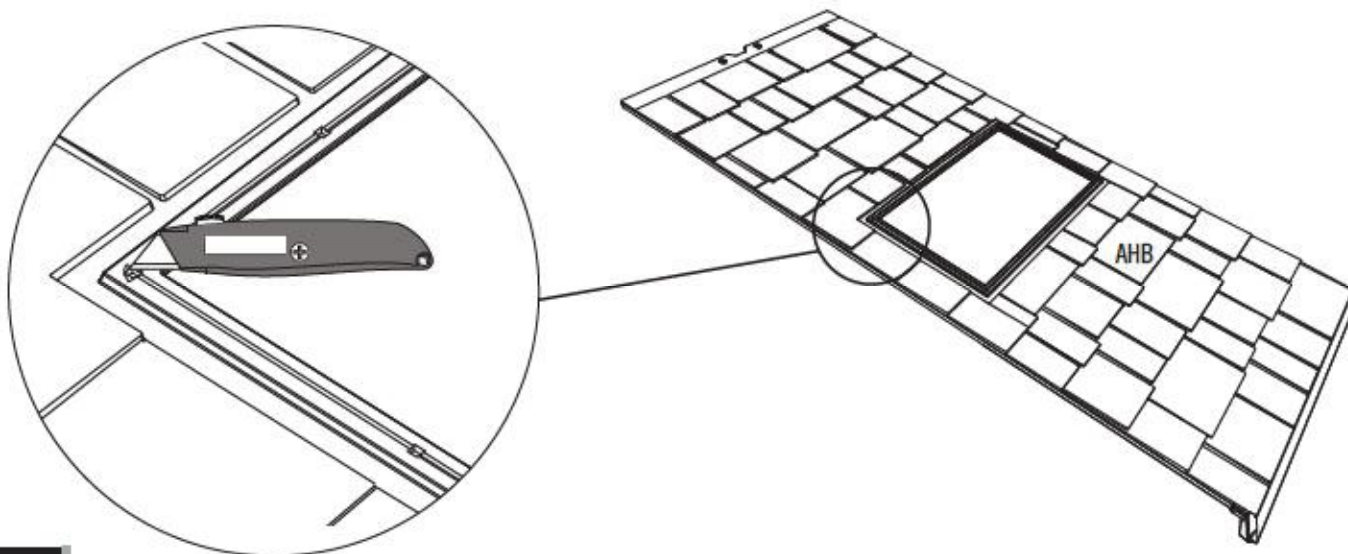

7.2

- Lay **Butyl Tape (AHI)** along the groove running along the top edge of the opening of the Panel. Cut the Butyl Tape.
- Mettre le **ruban butylique (AHI)** le long de la rainure qui s'étend le long du bord supérieur de la couverture du panneau. Couper le ruban butylique.
- Colocar la **cinta de butilo (AHI)** a lo largo de la ranura que corre a lo largo del borde superior de la abertura del panel. Cortar la cinta de butilo.

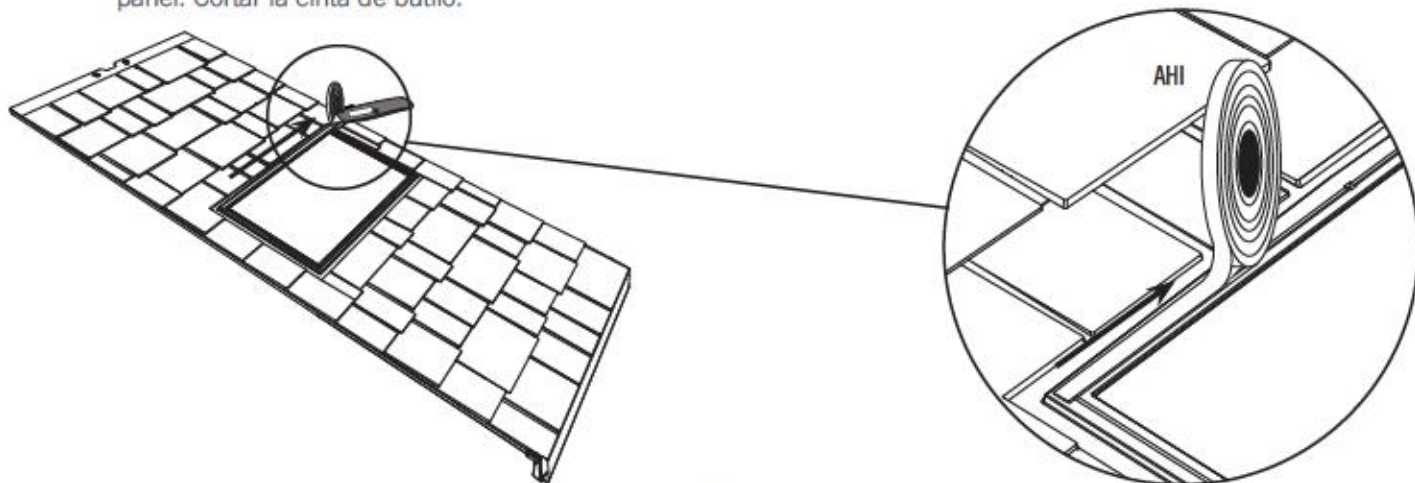

► SECTION 7 (CONTINUED) / SECTION 7 (SUITE) / SECCIÓN 7 (CONTINUACIÓN)

TOOLS AND HARDWARE REQUIRED / OUTILS ET QUINCAILLERIE REQUIS / INSTRUMENTAL Y HERRAJE REQUERIDOS



AHI (x2)

7.3

- **Do not remove any paper backing yet!** Lay **Butyl Tape (AHI)** along the groove running along the right edge of the opening of the Panel. Cut the Tape.
- **Ne pas retirer encore le papier protecteur !** Mettre le **ruban butylique (AHI)** le long de la rainure qui s'étend le long du bord droit de la couverture du panneau. Couper le ruban.
- **¡No retirar todavía el papel protector!** Colocar la **cinta de butilo (AHI)** a lo largo de la ranura que corre a lo largo del borde derecho de la abertura del panel. Cortar la cinta.

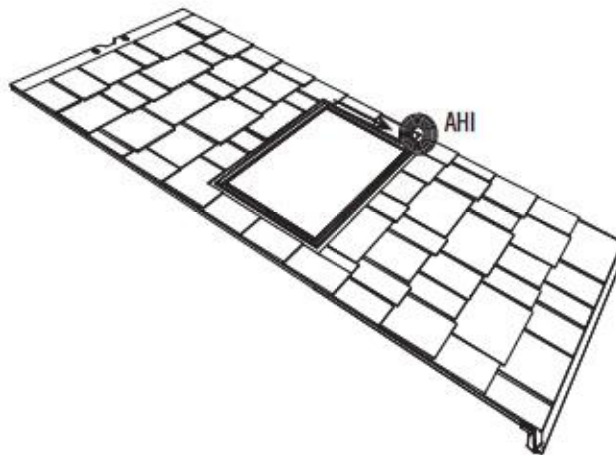

7.4

- **Do not remove any paper backing yet!** Lay **Butyl Tape (AHI)** along the groove running along the bottom edge of the opening of the Panel. Cut the Tape.
- **Ne pas retirer encore le papier protecteur !** Mettre le **ruban butylique (AHI)** le long de la rainure qui s'étend le long du bord inférieur de la couverture du panneau. Couper le ruban.
- **¡No retirar todavía el papel protector!** Colocar la **cinta de butilo (AHI)** a lo largo de la ranura que corre a lo largo del borde inferior de la abertura del panel. Cortar la cinta.

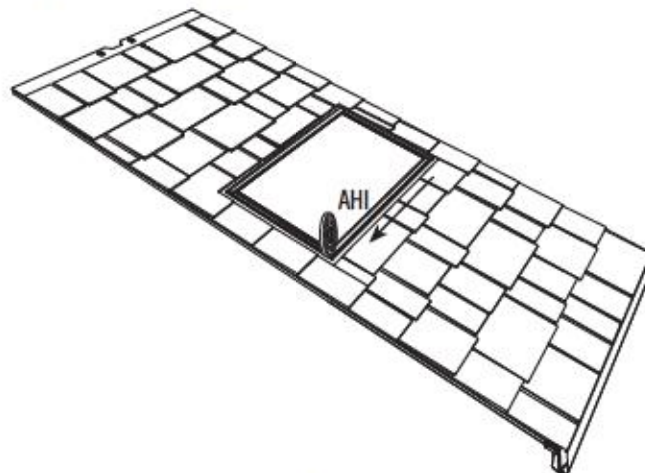

► SECTION 7 (CONTINUED) / SECTION 7 (SUITE) / SECCIÓN 7 (CONTINUACIÓN)

TOOLS AND HARDWARE REQUIRED / OUTILS ET QUINCAILLERIE REQUIS / INSTRUMENTAL Y HERRAJE REQUERIDOS



AHI (x2)

7.5

- **Do not remove any paper backing yet!** Lay **Butyl Tape (AHI)** along the groove running along the left edge of the opening of the Panel. Cut the Tape.
- **Ne pas retirer encore le papier protecteur !** Mettre le **ruban butylique (AHI)** le long de la rainure qui s'étend le long du bord gauche de la couverture du panneau. Couper le ruban.
- **¡No retirar todavía el papel protector!** Colocar la **cinta de butilo (AHI)** a lo largo de la ranura que corre a lo largo del borde izquierdo de la abertura del panel. Cortar la cinta.

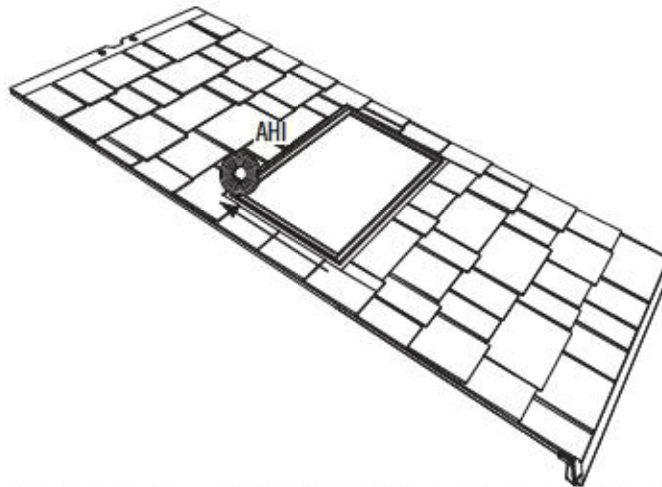

7.6

- **Smooth out the Tape to remove any bubbles.** Remove the paper backing. Using a plain screwdriver, poke holes through the Butyl Tape and through the holes in the Roof Panel. The holes in the Roof Panel must remain square.
- **Lisser le ruban pour éliminer des bulles.** Enlever la pellicule protectrice. Mettre un tournevis plat dans le ruban butylique et à travers les trous carrés dans le panneau de toit. Les trous dans le panneau de toit doivent rester carrés.
- **Alisar la cinta para eliminar cualquier burbuja.** Retirar el papel protector. Metar un destornillador de punta plana a través de la cinta de butilo y los agujeros cuadrados en el panel de tejado. Los agujeros en el panel de tejado deben quedarse cuadrados.

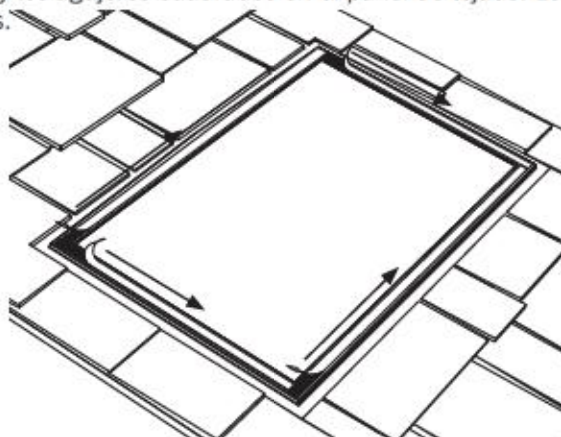

► SECTION 7 (CONTINUED) / SECTION 7 (SUITE) / SECCIÓN 7 (CONTINUACIÓN)

TOOLS AND HARDWARE REQUIRED / OUTILS ET QUINCAILLERIE REQUIS / INSTRUMENTAL Y HERRAJE REQUERIDOS



3/8 in/po
(10 mm)



EFA (x24)



ADK (x24)



AEE (x48)

7.7

- Remove the protective film from both sides of the **Skylight (AGB)**.
- Soulever la pellicule protectrice des deux côtés de la **lucarne (AGB)**.
- Retirar la capa protectora de los dos caras del **tragaluz (AGB)**.

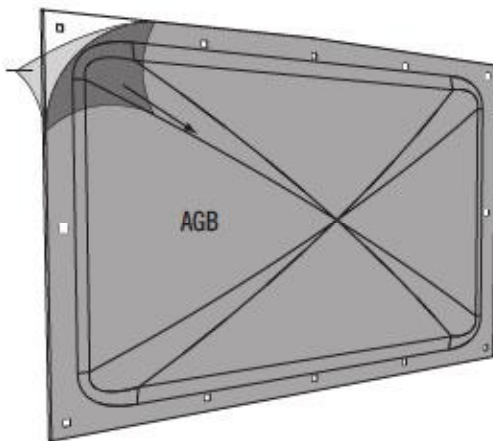

7.8

- Align the holes in the Skylight with those in the Panel, and lay the Skylight on the Panel. Press the Skylight onto the Butyl Tape to remove any bubbles.
- Aligner les trous dans la lucarne avec ceux dans le panneau, et mettre la lucarne sur le panneau. Pousser la lucarne contre le ruban pour éliminer des bulles.
- Alinear los agujeros en el tragaluz con ellos en el panel, y colocar el tragaluz en el panel. Empujar el tragaluz contra la cinta para eliminar las burbujas.

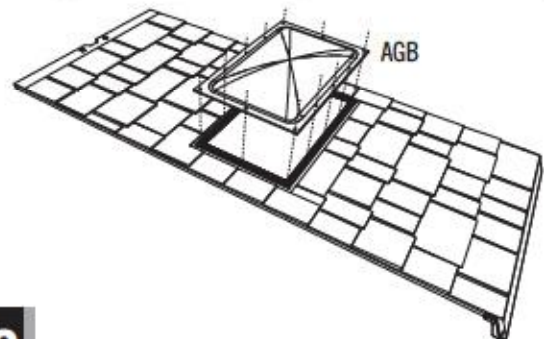

7.9

- Secure the Skylight to the Panel using the hardware provided.
- Attacher la lucarne au panneau à l'aide de la quincaillerie incluse.
- Sujetar el tragaluz al panel usando el herraje incluido.

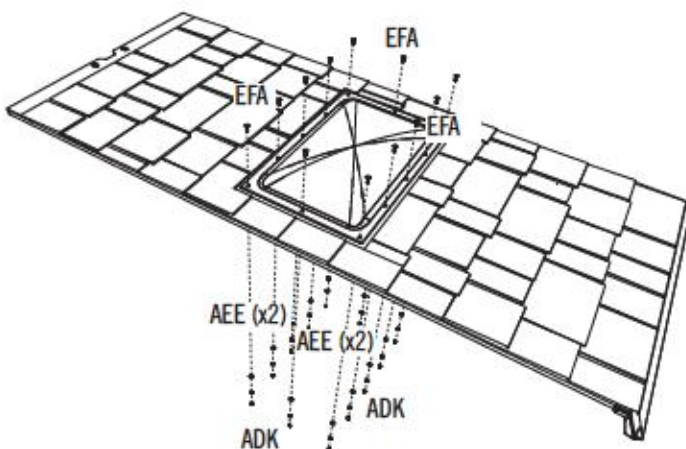

7.10

- Repeat this section for the **second Domed Skylight**.
- Répéter cette section pour la deuxième lucarne en forme de dôme.
- Repetir esta sección para el segundo tragaluz en forma de cúpula.

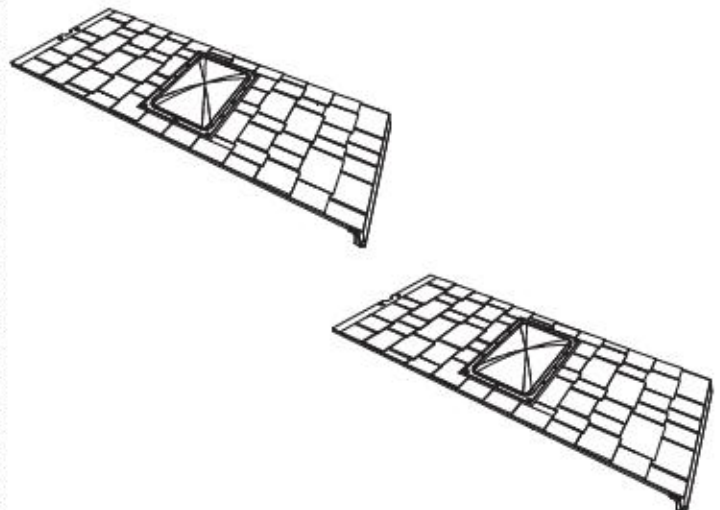

8

FLOOR ASSEMBLY / ASSEMBLAGE DU PLANCHER / ENSAMBLE DEL PISO



HARDWARE REQUIRED / QUINCAILLERIE REQUISE / HERRAJE REQUERIDO

Hardware Bags / Sacs de quincaillerie / Bolsas de herraje



0, 3 oder, of, eller 4

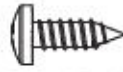

BQC (x50-x98)



ADC (x1)



*Note: These Screws do not anchor the Floor; they only hold the Panels together.
Note : Ces vis n'ancrent pas le plancher ; ils ne servent que pour attacher les panneaux les uns aux autres.
Nota: Estos tornillos no anclan el piso; sirven sólo para sujetar los paneles los unos a los otros.*



PARTS REQUIRED / PIÈCES REQUISES / PIEZAS REQUERIDAS

Plastic Parts / Pièces en plastique / Piezas de plástico



AGJ (x6, x12, or x14)

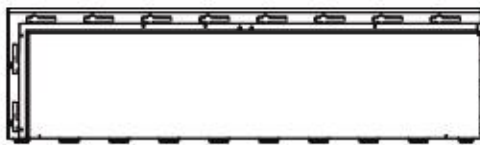

AGS (x2)



AGT (x2)



TOOLS REQUIRED / OUTILS REQUIS / INSTRUMENTAL REQUERIDO



(x1)



(x1)

► SECTION 8 (CONTINUED) / SECTION 8 (SUITE) / SECCIÓN 8 (CONTINUACIÓN)

TOOLS AND HARDWARE REQUIRED / OUTILS ET QUINCAILLERIE REQUIS / INSTRUMENTAL Y HERRAJE REQUERIDOS



8.1



- Hold an **Outer Floor Panel (AGS)** at an angle and slide the tabs along the edge underneath the other **Outer Floor Panel (AGT)**. The tabs interlock. Lay Panel down flat.
- Poser un **panneau de plancher extérieur (AGS)** à un angle et faire glisser les languettes le long du bord au-dessus de l'autre **panneau de plancher extérieur (AGT)**. Les languettes s'enclenchent les uns les autres. Étendre-le par terre.
- Colocar un **panel de piso exterior (AGS)** a un ángulo y deslizar las lengüetas a lo largo del borde debajo el otro **panel de piso exterior (AGT)**. Las lengüetas se entrelazan las unas con las otras. Aplanar el panel.

- ! Do not place any sharp objects on Floor.
- ! Ne placer aucun objet tranchant sur le plancher.
- ! No ponga ningún objeto afilado en el piso.

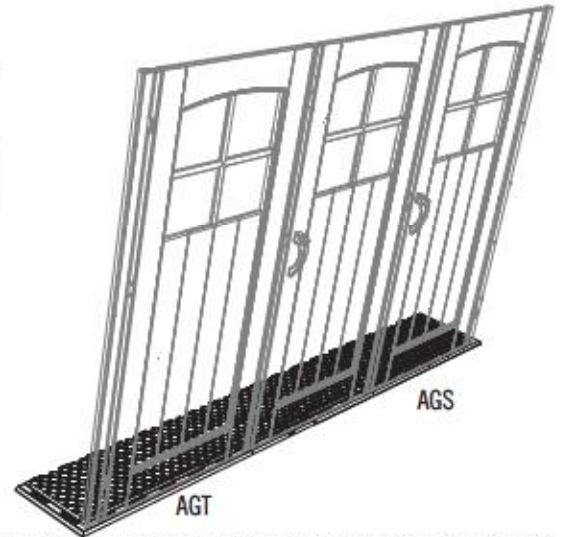
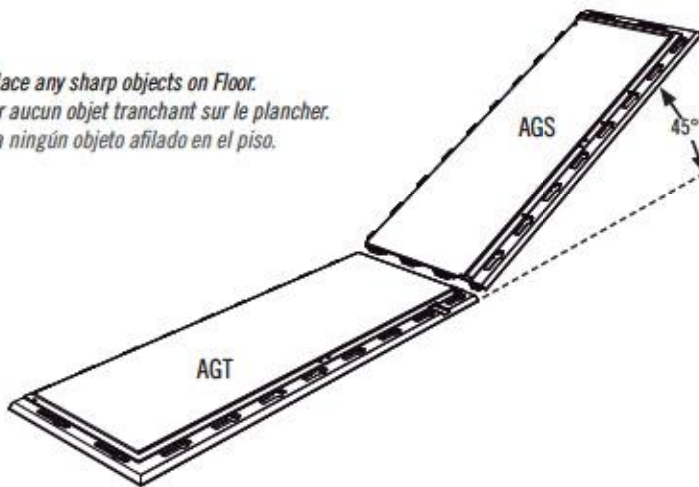

8.2

- Join two **Inner Floor Panels (AGJ)**. Then, slide the tabs along the edge underneath the first two Outer Floor Panels. The tabs interlock. Lay the Panels down flat.
- Attacher deux **panneaux de plancher intérieurs (AGJ)**. Ensuite, faire glisser les languettes le long du bord au-dessus des autres panneaux de plancher extérieurs. Les languettes s'enclenchent les uns les autres. Étendre-les par terre.
- Juntar dos **paneles de piso interiores (AGJ)**. Entonces, deslizar las lengüetas a lo largo del borde debajo los otros paneles de piso exteriores. Las lengüetas se entrelazan las unas con las otras. Aplanar los paneles.

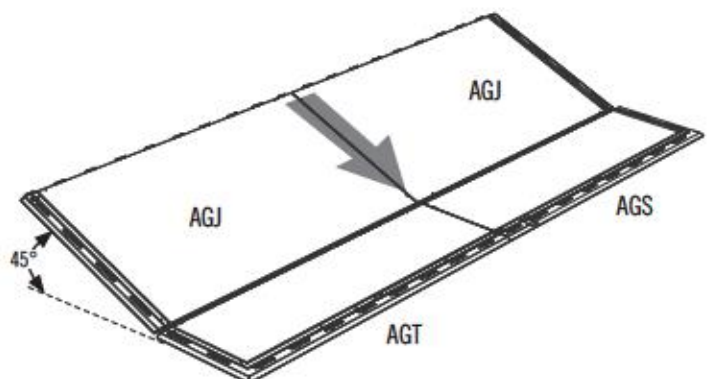
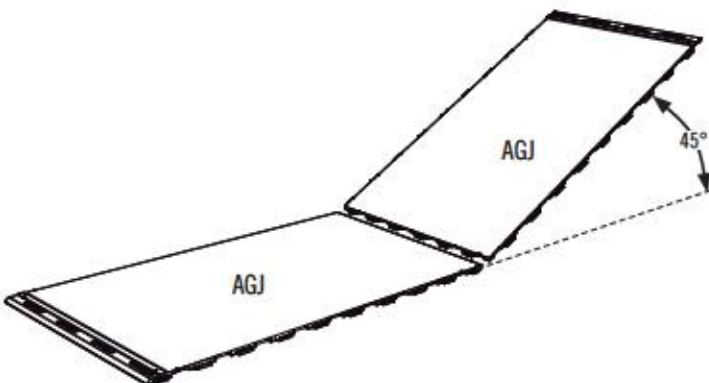

► SECTION 8 (CONTINUED) / SECTION 8 (SUITE) / SECCIÓN 8 (CONTINUACIÓN)

TOOLS AND HARDWARE REQUIRED / OUTILS ET QUINCAILLERIE REQUIS / INSTRUMENTAL Y HERRAJE REQUERIDOS



8.3

• Continue joining two (2) **Inner Floor Panels (AGJ)** and connecting them to the previous Panels. The 11'x11' (3.4 m x 3.4 m) shed uses six (6) Inner Floor Panels, the 11'x18.5' (3.4 m x 5.6 m) shed uses twelve (12) Inner Floor Panels, and the 11'x21' (3.4 m x 6.4 m) shed uses fourteen (14) Inner Floor Panels. Finally, attach the last two (2) **Outer Floor Panels (AGS & AGT)** to the Inner Floor Panels.

• Continuer d'assembler deux (2) **panneaux de plancher intérieurs (AGJ)** et de les attacher aux panneaux précédents. L'abri de 3,4 m x 3,4 m consiste en six (6) panneaux de plancher intérieurs, l'abri de 3,4 m x 5,6 m consiste en douze (12) panneaux de plancher intérieurs, et l'abri de 3,4 m x 6,4 m consiste en quatorze (14) panneaux de plancher intérieurs. Enfin, attacher les deux (2) derniers **panneaux de plancher extérieurs (AGS et AGT)** aux panneaux de plancher intérieurs.

• Continuar a juntar dos (2) **paneles de piso interiores (AGJ)** y a conectarlos a los paneles anteriores. La caseta de 3,4 m x 3,4 m consiste de seis (6) paneles de piso interiores, la caseta de 3,4 m x 5,6 m consiste de doce (12) paneles de piso interiores, y la caseta de 3,4 m x 6,4 m consiste de catorce (14) paneles de piso interiores. Por último, sujetar los últimos dos (2) **paneles de piso exteriores (AGS y AGT)** a los paneles de piso interiores.

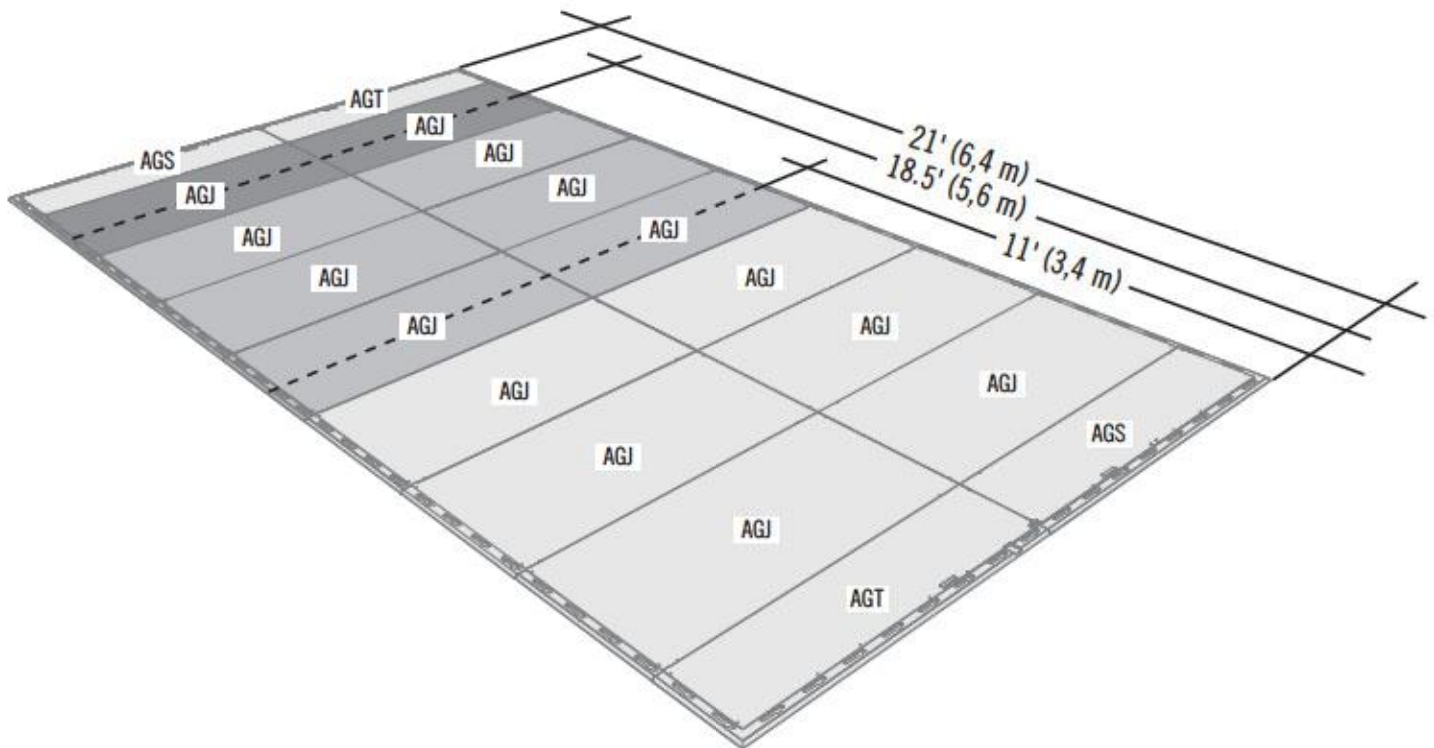

► SECTION 8 (CONTINUED) / SECTION 8 (SUITE) / SECCIÓN 8 (CONTINUACIÓN)

TOOLS AND HARDWARE REQUIRED / OUTILS ET QUINCAILLERIE REQUIS / INSTRUMENTAL Y HERRAJE REQUERIDOS

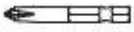

ADC (x1)

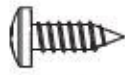

BQC (x50)
60237

or/ou/o

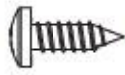

BQC (x44)
60236

or/ou/o

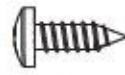

BQC (x26)
60187



Note: These Screws do not anchor the Floor; they only hold the Panels together.

Note : Ces vis n'ancrent pas le plancher ; ils ne servent que pour attacher les panneaux les uns aux autres.

Nota: Estos tornillos no anclan el piso; sirven sólo para sujetar los paneles los unos a los otros.

8.4

- Use a screwdriver or drill to connect the Panels together using the **screws (BQC)** provided: (1) four Screws in the divots at each seam intersection, (2) one Screw in the divot near each end of the center seam, and (3) one Screw in the divot near each seam along the sides of the Floor. **Do not overtighten.**
- Employer un tournevis or perceuse électrique pour fixer les panneaux les uns les autres en utilisant les **vis (BQC)** incluses : (1) quatre vis dans les marques aux intersections de chaque jointure, (2) une vis près chaque extrémité de la jointure centrale, et (3) une vis dans la marque près chaque jointure le long des bords latéraux du plancher. **Ne pas trop serrer.**
- Usar un destornillador o taladro eléctrico para fijar los paneles usando los **tornillos (BQC)** incluidos: (1) cuatro tornillos en las marcas a los cruces de cada línea, (2) un tornillo en la marca cerca cada extremo de la línea central, y (3) un tornillo en la marca cerca cada línea a lo largo de los bordes laterales del piso. **No apretar demasiado.**

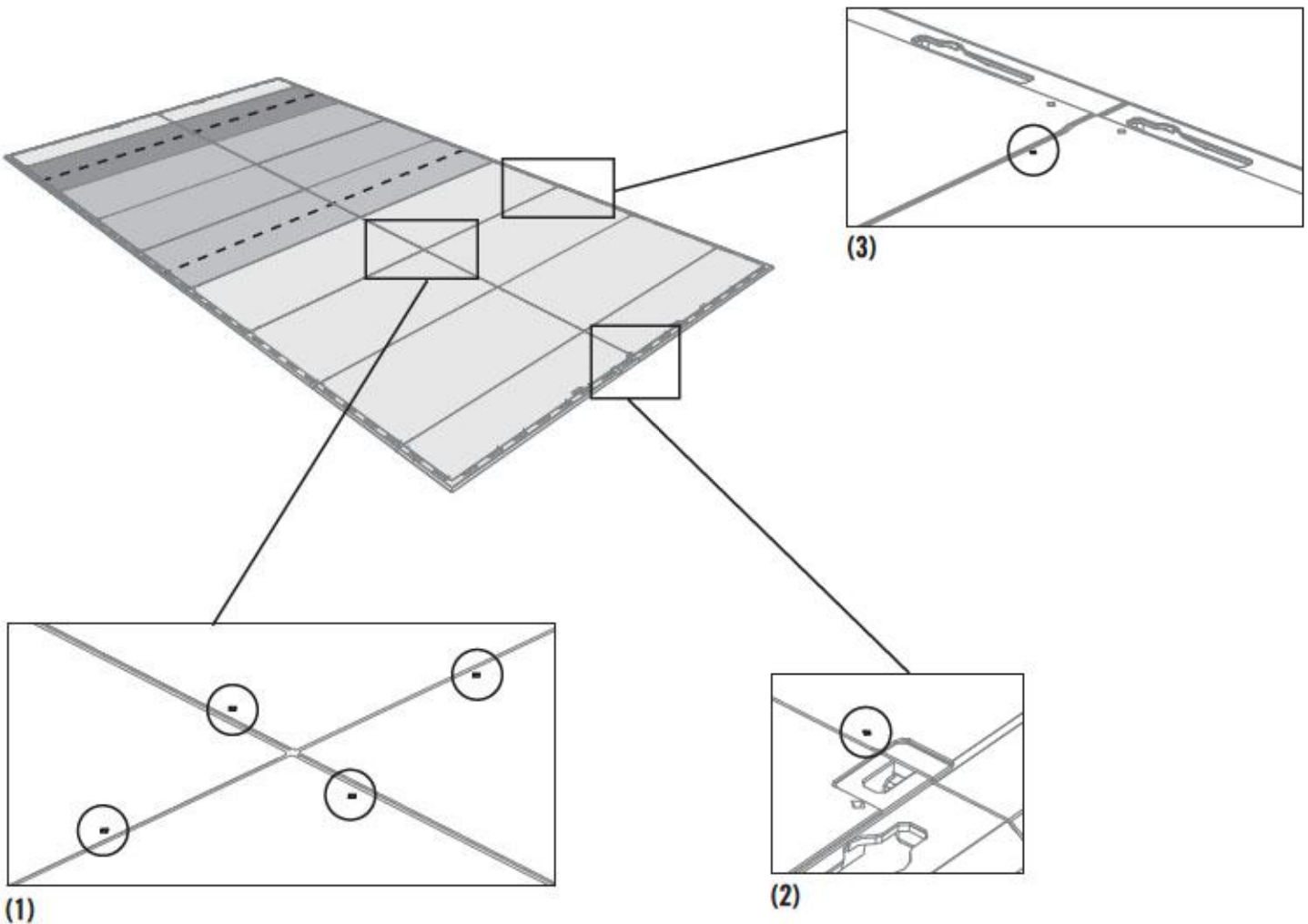

9

WALL ASSEMBLY / ASSEMBLAGE DES MURS / ENSAMBLE DE LOS MUROS



HARDWARE REQUIRED / QUINCAILLERIE REQUISE / HERRAJE REQUERIDO

Hardware Bags / Sacs de quincaillerie / Bolsas de herraje

(11', 18.5', 21')

(18.5')

(21')

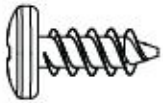

ADZ (x78, 120, or, ou, o 132)



ADC (x1)

!

- The quantities of the hardware shown below vary due to the size of your shed. Bag **EZN** is used for all three sheds. Bags **BGT** are used for both the 18.5' (5,6 m) and 21' (6,4 m) sheds.
- Les quantités de la quincaillerie illustrées à gauche varient selon le longueur de votre abri. Le sac **EZN** est utilisé pour tous les trois abris. Les sacs **BGT** sont utilisés pour les abris de 5,6 m et 6,4 m.
- Las cantidades de herraje ilustradas a la izquierda varían según el largo de su caseta. Se usa la bolsa **EZN** para todas las tres casetas. Se usan las bolsas **BGT** para la caseta de 6,4 m.



PARTS REQUIRED / PIÈCES REQUISES / PIEZAS REQUERIDAS

Metal Parts / Pièces en métal / Piezas de metal



AFR (x2)



Plastic Parts / Pièces en plastique / Piezas de plástico

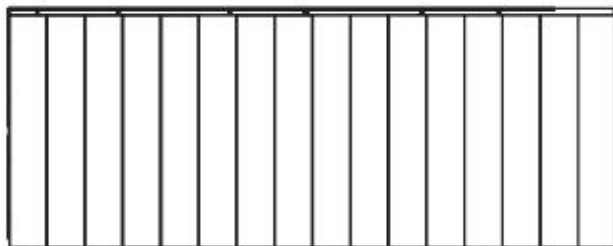

AHD (x6, x12, or, ou, o x14)

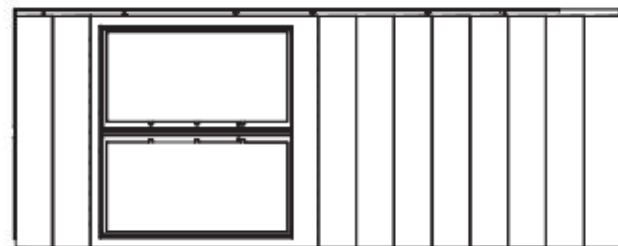

AHH (x2, 4, or, ou, o 6)



TOOLS REQUIRED / OUTILS REQUIS / INSTRUMENTAL REQUERIDO



► SECTION 9 (CONTINUED) / SECTION 9 (SUITE) / SECCIÓN 9 (CONTINUACIÓN)

TOOLS AND HARDWARE REQUIRED / OUTILS ET QUINCAILLERIE REQUIS / INSTRUMENTAL Y HERRAJE REQUERIDOS



9.1



• Insert the tabs at the bottom of the **Wall Panel (AHD)** into the four slots along the right, front corner of the Floor. Slide the Panel forward.

• Insérer les languettes au bord inférieur du **panneau mural (AHD)** dans les quatre rainures le long du coin avant droit du plancher. Faire glisser le panneau vers le bord avant.

• Insertar las lengüetas al borde inferior del **panel mural (AHD)** en las cuatro ranuras a lo largo de la esquina delantera derecha del piso. Deslizar el panel hacia el borde delantero.

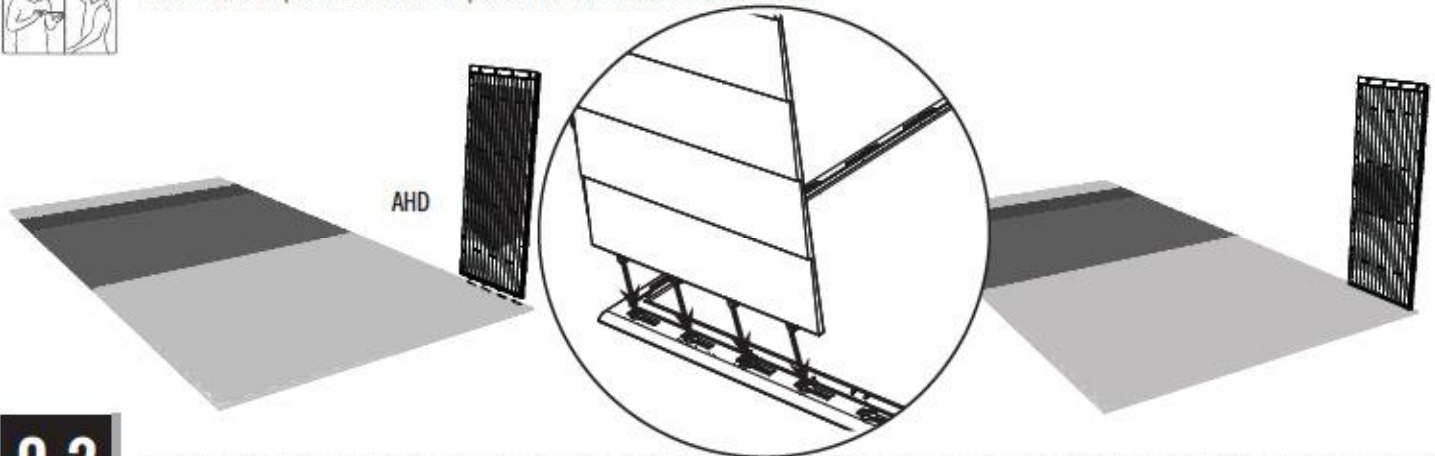

9.2

• One by one, insert the tabs of the next three Panels into the next slots along the right side of the Floor, and slide them toward the front. **The Window Wall Panels (AHH) may be placed in any non-corner position along the sides of the shed.**

• Un par un, insérer les languettes des trois panneaux dans les fentes suivantes le long du bord droit du plancher, et faire glisser-les vers le bord avant. **Le panneau avec fenêtre s'insère (AHH) dans n'importe quel endroit, sauf les encoignures, le long des bords latéraux.**

• Uno por uno, insertar las lengüetas de los próximos tres paneles en las próximas ranuras a lo largo del borde derecho del piso, y deslizarlos hacia el borde delantero. **Se puede insertar el panel mural para la ventana (AHH) en cualquier posición, salvo las esquinas, a lo largo de los bordes laterales.**

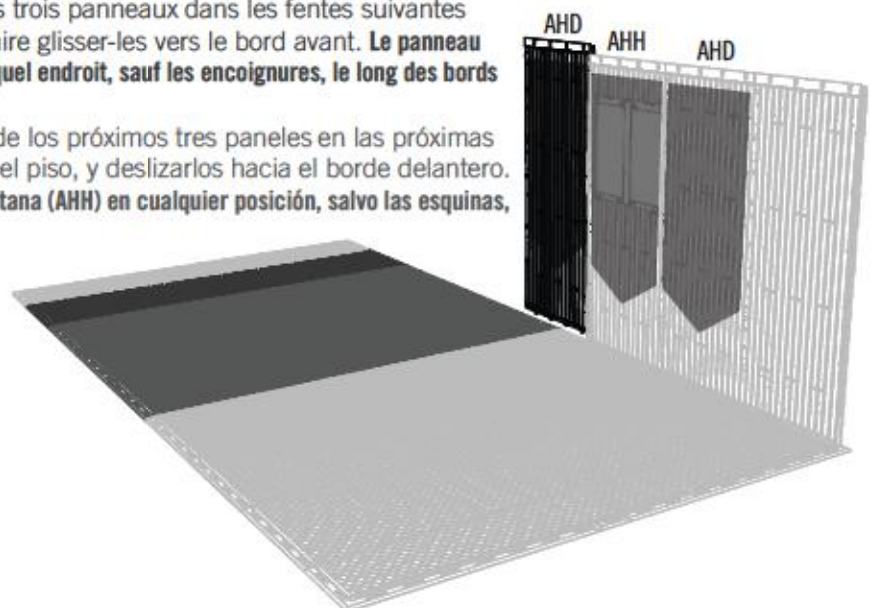

► SECTION 9 (CONTINUED) / SECTION 9 (SUITE) / SECCIÓN 9 (CONTINUACIÓN)

TOOLS AND HARDWARE REQUIRED / OUTILS ET QUINCAILLERIE REQUIS / INSTRUMENTAL Y HERRAJE REQUERIDOS

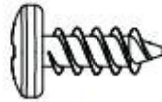

ADZ (x18, 36, or 42)

9.3

- Align the holes in adjacent Panels, and secure them with six (6) **Screws (ADZ)** at each seam. **If you have an 11' x 11' (3,35 m x 3,35 m) shed, skip to step 9.5.**
- Aligner les trous dans les panneaux contigus, et attacher-les à l'aide de six (6) **vis (ADZ)** pour chaque jointure. **Avec l'abri de 3,35 m x 3,35 m, continuer à l'étape 9.5.**
- Alinear los agujeros en los paneles adyacentes, y sujetarlos usando seis (6) **tornillos (ADZ)** para cada junta. **Con la caseta de 3,35 m x 3,35 m, continuar al paso 9.5.**

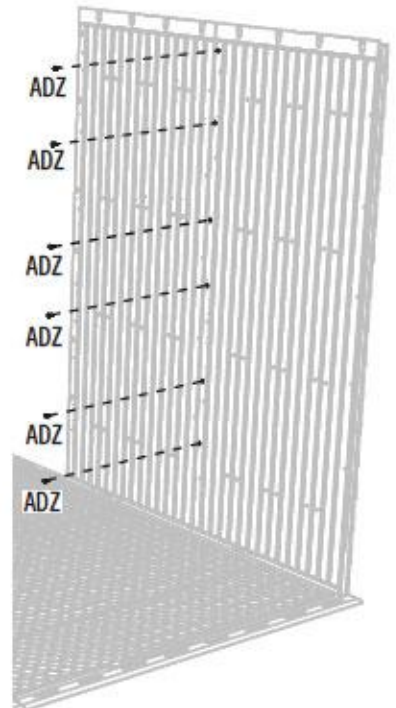

9.4

- The 18.5' shed uses seven (7) **Panels (ADH and AHH)** along the side. The 21' shed has eight (8) Panels. Continue attaching Panels to one another until you reach the end of your Floor. Align the holes in adjacent Panels, and secure them with six (6) **Screws (ADZ)** at each seam. **Avoid installing a Window Wall Panel at a corner.**
- L'abri de 5,64 m utilise sept (7) **panneaux (ADH et AHH)** le long du bord latéral. L'abri de 6,40 m utilise huit (8) panneaux. Continuer d'attacher les panneaux l'un à l'autre jusqu'au coin arrière de votre plancher. Aligner les trous dans les panneaux contigus, et attacher-les à l'aide de six (6) **vis (ADZ)** pour chaque jointure. **Éviter d'installer un panneau mural avec fenêtre à un coin.**
- La caseta de 5,64 m usa siete (7) **paneles (ADH y AHH)** mientras que la caseta de 6,40 usa ocho (8). Continuar de sujetar los paneles los unos a los otros hasta que llegue a la esquina trasera de su piso. Alinear los agujeros en los paneles adyacentes, y sujetarlos usando seis (6) **tornillos (ADZ)** para cada junta. **Evitar de instalar un panel mural con ventana a una esquina.**

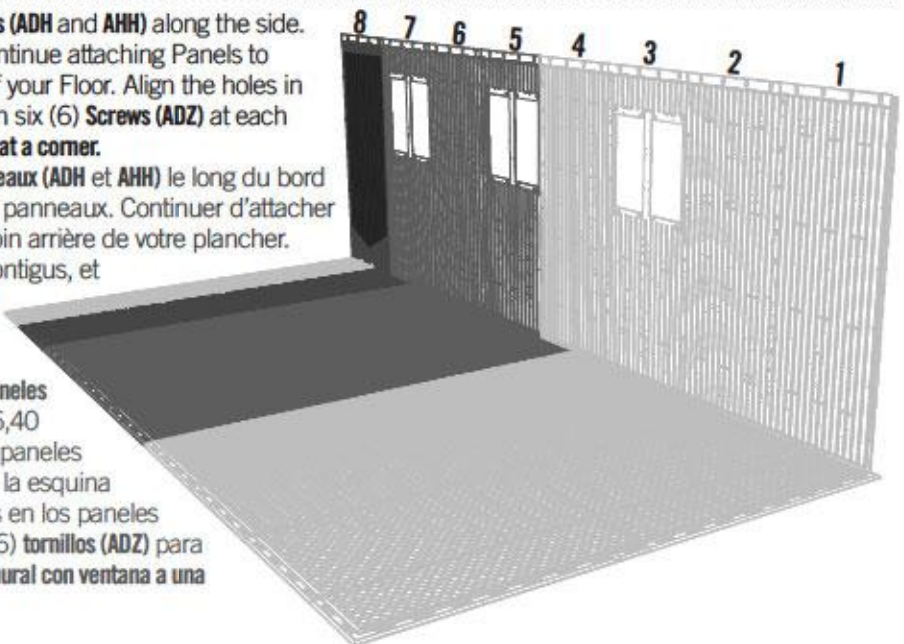

► SECTION 9 (CONTINUED) / SECTION 9 (SUITE) / SECCIÓN 9 (CONTINUACIÓN)

TOOLS AND HARDWARE REQUIRED / OUTILS ET QUINCAILLERIE REQUIS / INSTRUMENTAL Y HERRAJE REQUERIDOS

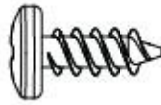

ADZ (x12)

9.5

• The installation of the rear Wall Panels is the same for all the depths of our sheds. Insert a **Wall Panel (AHD)** into the four slots next to the right rear corner of the shed. Slide the Panel to the right. **Window Wall Panels are only installed on the sides of the sheds.**

• Les panneaux muraux s'installent le long du bord arrière de la même façon que pour tous les profondeurs de nos abris. Insérer un **panneau mural (AHD)** dans les quatre fentes près du coin arrière droit de l'abri comme illustré. Faire glisser le panneau à droite. **Installer les panneaux muraux avec fenêtre seulement le long des bords latéraux.**

• Se instalan los paneles murales traseros de la misma manera que para todas las profundidades de nuestras casetas. Inserte un **panel mural (AHD)** en las cuatro ranuras junto a la esquina trasera derecha de la caseta. Deslizar el panel a la derecha. **Se instalan los paneles murales con ventana sólo a lo largo de los bordes laterales del piso.**

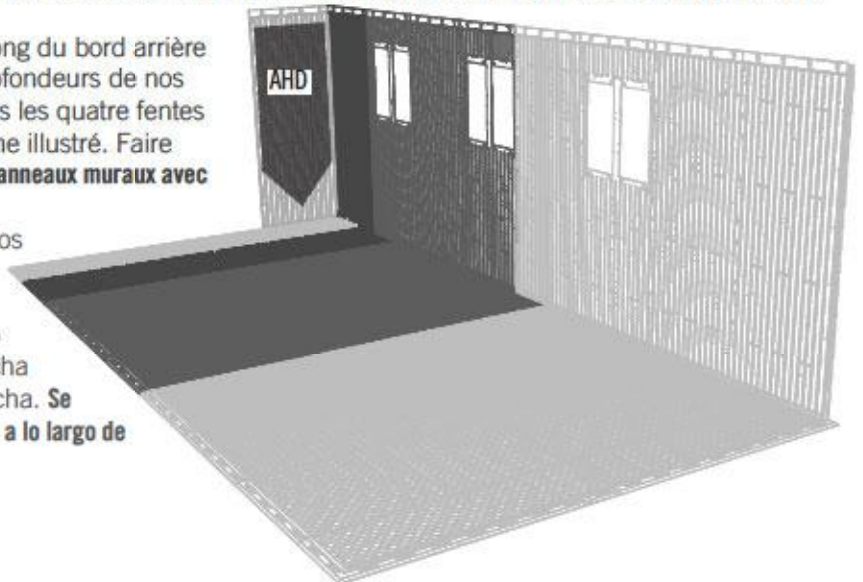

9.6

• Align the holes in a **Corner Channel (AFR)** with the holes where the two Panels connect. Attach the Corner Channel to the Panels using the included hardware. **This step is done for each corner.**

• Aligner les trous dans le **canal angulaire (AFR)** avec les trous le long des bords des deux panneaux qui forment l'encoignure. Attacher le canal angulaire aux panneaux à l'aide de la quincaillerie incluse. **Il faut faire cette étape pour chaque coin.**

• Alinear los agujeros en un **canal angular (AFR)** con los agujeros a lo largo de los dos paneles que forman el ángulo. Sujetar el canal angular a los paneles usando el herraje incluido. **Se hace este paso para cada esquina.**



ADZ (x12)



AFR

Top / Partie supérieure / Parte superior

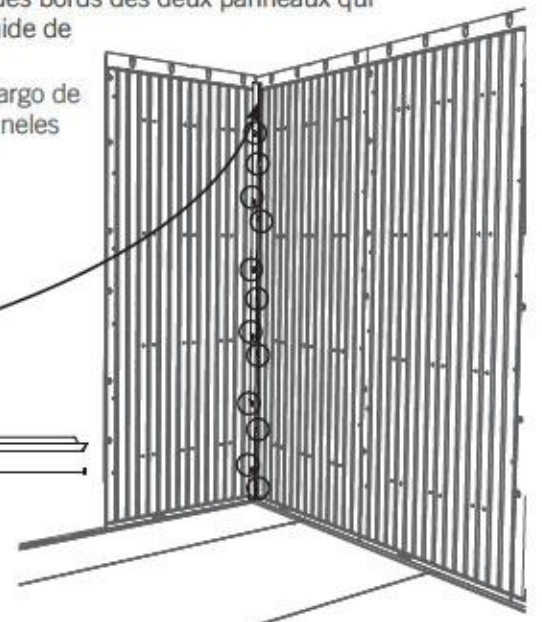

► SECTION 9 (CONTINUED) / SECTION 9 (SUITE) / SECCIÓN 9 (CONTINUACIÓN)

TOOLS AND HARDWARE REQUIRED / OUTILS ET QUINCAILLERIE REQUIS / INSTRUMENTAL Y HERRAJE REQUERIDOS

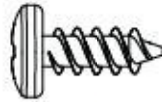

ADZ (x18)

9.7

- Attach the next three **Wall Panels (AHD)** along the rear of the Floor in the same manner as before.
- Attacher les trois **panneaux muraux (AHD)** suivants le long du bord arrière du plancher dans la même façon que les panneaux précédents.
- Sujetar los próximos tres **paneles murales (AHD)** a lo largo del borde trasero del piso en la misma manera que los paneles precedentes.

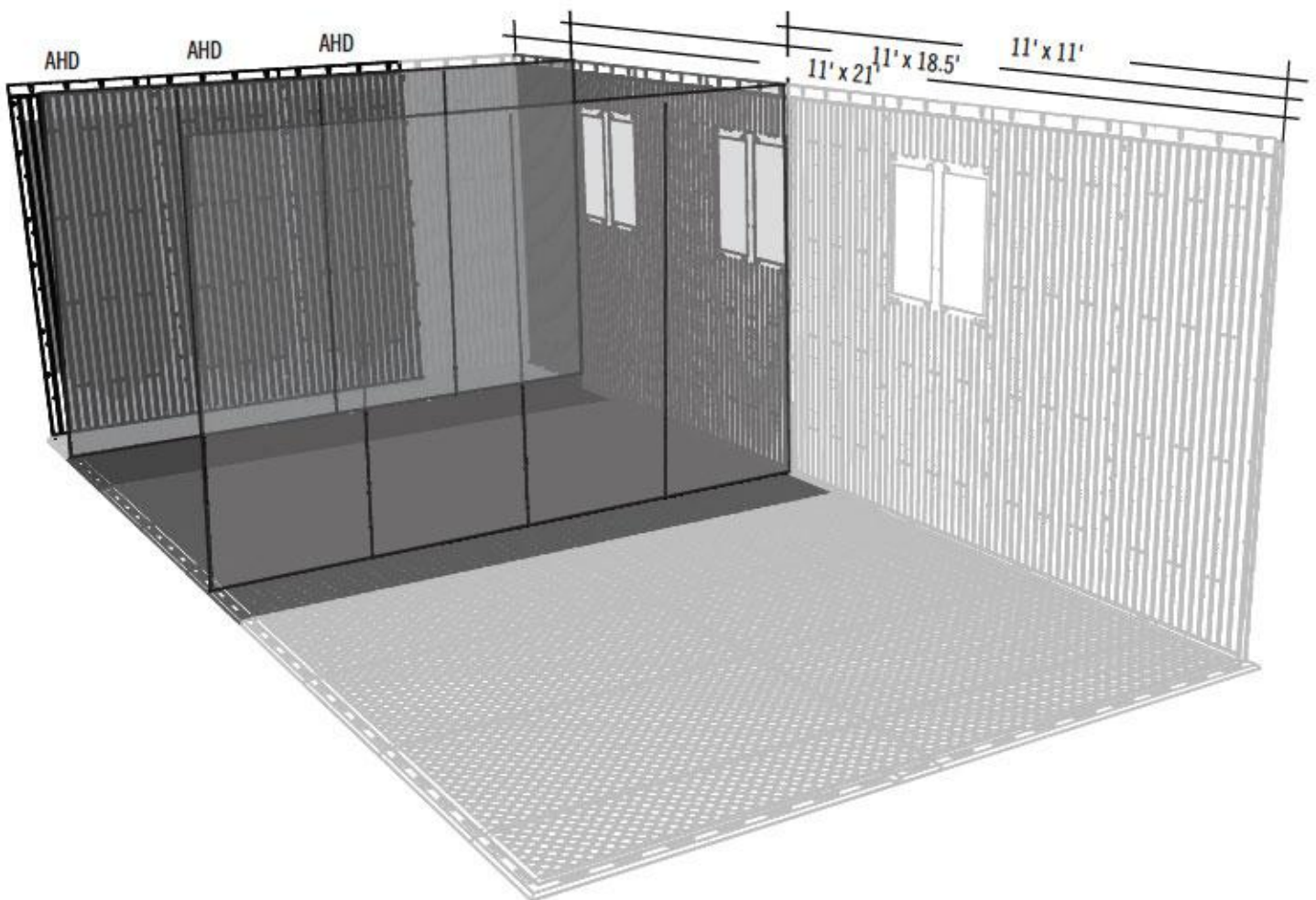

► SECTION 9 (CONTINUED) / SECTION 9 (SUITE) / SECCIÓN 9 (CONTINUACIÓN)

TOOLS AND HARDWARE REQUIRED / OUTILS ET QUINCAILLERIE REQUIS / INSTRUMENTAL Y HERRAJE REQUERIDOS

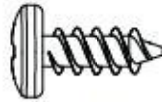

ADZ (x30, 54, or 60)

9.8

- The 11' shed uses four (4) **Panels (ADH and AHH)** along the side. The 18.5' shed uses seven (7) and the 21' shed has eight (8). Continue attaching Panels to one another until you reach the front left corner of your Floor. Align the holes in adjacent Panels, and secure them with six (6) **Screws (ADZ)** at each seam. Attach the Corner Channel to the left rear corner Panels using twelve (12) **Screws (ADZ)**.
- L'abri de 3,35 m utilise quatre (4) **panneaux (ADH et AHH)** le long du bord latéral. L'abri de 5,64 m utilise sept (7) panneaux, et l'abri de 6,40 m utilise huit (8) panneaux. Attacher les panneaux l'un à l'autre jusqu'au coin avant gauche du plancher. Aligner les trous dans les panneaux contigus, et attacher-les à l'aide de six (6) **vis (ADZ)** pour chaque jointure. Attacher le canal angulaire aux panneaux au coin arrière gauche à l'aide de douze (12) **vis (ADZ)**.
- La caseta de 3,35 m usa cuatro (4) **paneles (ADH y AHH)**. La caseta de 5,64 m usa siete (7) paneles mientras que la caseta de 6,40 usa ocho (8). Continuar de sujetar los paneles los unos a los otros hasta la esquina delantera izquierda del piso. Alinear los agujeros en los paneles adyacentes, y sujetarlos usando seis (6) **tornillos (ADZ)** para cada juntura. Sujetar el canal angular a los paneles en la esquina trasera izquierda usando doce (12) **tornillos (ADZ)**.

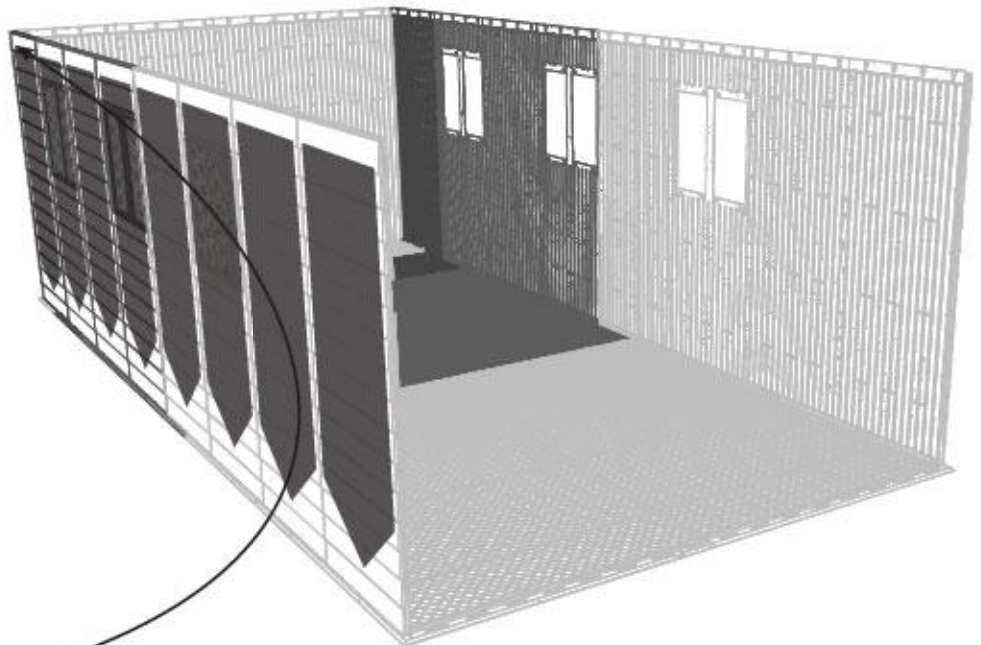

AFR

Top / Partie supérieure / Parte superior



HARDWARE REQUIRED / QUINCAILLERIE REQUISE / HERRAJE REQUERIDO

Hardware Bag / Sac de quincaillerie / Bolsa de herraje

(11', 18.5', 21')

(18.5')

(21')

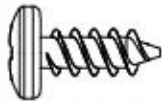

ADZ (x92, 136, or 148)

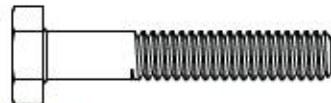

AAK (x12)



ADJ (x12)



AHT (x4)



• The quantities of the hardware shown vary due to the size of your shed. Bag **EXU** is used for all three sheds. Bags **BGT** are used for both the 18.5' (5,6 m) and 21' (6,4 m) sheds.

• Les quantités de la quincaillerie illustrées à gauche varient selon le longueur de votre abri. Le sac **EXU** est utilisé pour tous les trois abris. Les sacs **BGT** sont utilisés pour les abris de 5,6 m et 6,4 m.

• Las cantidades de herraje ilustradas a la izquierda varían según el largo de su caseta. Se usa la bolsa **EXU** para todas las tres casetas. Se usan las bolsas **BGT** para la caseta de 6,4 m.



PARTS REQUIRED / PIÈCES REQUISES / PIEZAS REQUERIDAS

Metal Parts / Pièces en métal / Piezas de metal



AFQ (x4)



AFJ (x2)



AFN (x2)

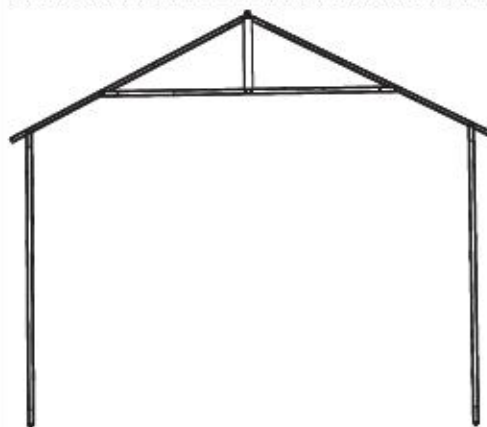

(x4, 7, or 8)



TOOLS REQUIRED / OUTILS REQUIS / INSTRUMENTAL REQUERIDO



7/16 in/po (11 mm) (x2)

► SECTION 10 (CONTINUED) / SECTION 10 (SUITE) / SECCIÓN 10 (CONTINUACIÓN)

TOOLS AND HARDWARE REQUIRED / OUTILS ET QUINCAILLERIE REQUIS / INSTRUMENTAL Y HERRAJE REQUERIDOS

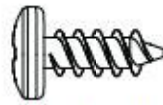

ADZ (x60, 104, or 116)

10.1

- Starting at the rear of the shed, place the Trusses in the centers of opposite Wall Panels (Regular and Window). Align the holes, and secure with sixteen (16) **Screws (ADZ)** per Truss for a regular Wall Panel and twelve/fourteen (12/14) **Screws (ADZ)** per Truss on a Window Wall Panel. **The 11' shed uses four (4) Trusses, the 18.5' shed uses seven (7), and the 21' shed uses eight (8).**
- En commençant à l'arrière de l'abri, mettre les fermes aux centres des panneaux muraux opposés (les normaux et ceux pour la fenêtre). Aligner les trous, et attacher les fermes aux panneaux à l'aide de seize (16) **vis (ADZ)** par ferme pour un panneau mural normal et douze/quatorze (12/14) **vis (ADZ)** pour les panneaux muraux pour la fenêtre. **L'abri de 3,4 m utilise quatre (4) fermes, l'abri de 5,6 m utilise sept (7), et l'abri de 6,4 m utilise huit (8).**
- Empezando a la parte trasera de la caseta, colocar las cerchas en los centros de los paneles murales opuestos (los normales y los para las ventanas). Alinear los agujeros, y sujetarlas usando dieciseis (16) **tornillos (ADZ)** por cercha para un panel mural normal y doce/catorce (12/14) **tornillos (ADZ)** por cercha para un panel mural para la ventana. **La caseta de 3,4 m usa cuatro (4) cerchas, la caseta de 5,6 m usa siete (7), y l'abri de 6,4 m usa ocho (8).**

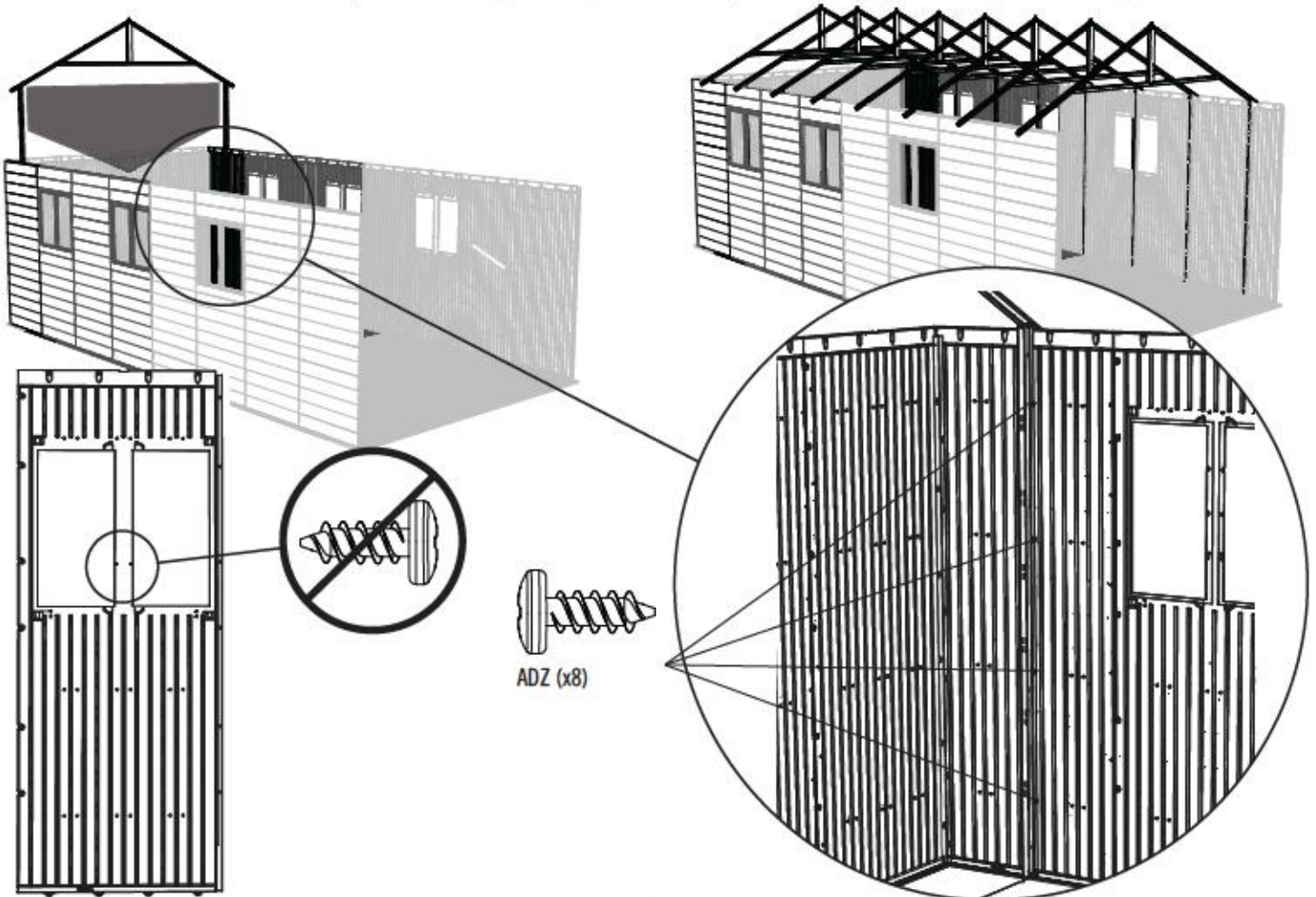

► SECTION 10 (CONTINUED) / SECTION 10 (SUITE) / SECCIÓN 10 (CONTINUACIÓN)

TOOLS AND HARDWARE REQUIRED / OUTILS ET QUINCAILLERIE REQUIS / INSTRUMENTAL Y HERRAJE REQUERIDOS



7/16 in/po (x2)
(11 mm (x2))

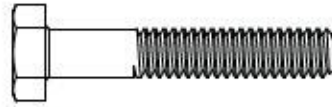

AAK (x8)



ADJ (x8)

10.2

• Place a **Short Wall Channel Extension (AFN)** into the top of the Wall Channel. Secure with two (2) **Bolts (AAK)** and two (2) **Cap Nuts (ADJ)**. **Do not overtighten. Repeat this step.**

• Insérer un **rallonge court pour le support mural (AFN)** dans l'extrémité supérieure du support mural. Attacher-le au support à l'aide de deux (2) **boulons (AAK)** et deux (2) **écrous à chape (ADJ)**. **Ne pas trop serrer. Répétez cette étape.**

• Colocar una **extensión corta para el soporte mural (AFN)** dentro del extremo superior del soporte mural. Sujetarla usando dos (2) **pernos (AAK)** y dos (2) **tuercas ciegas (ADJ)**. **No apretar demasiado. Repetir este paso.**

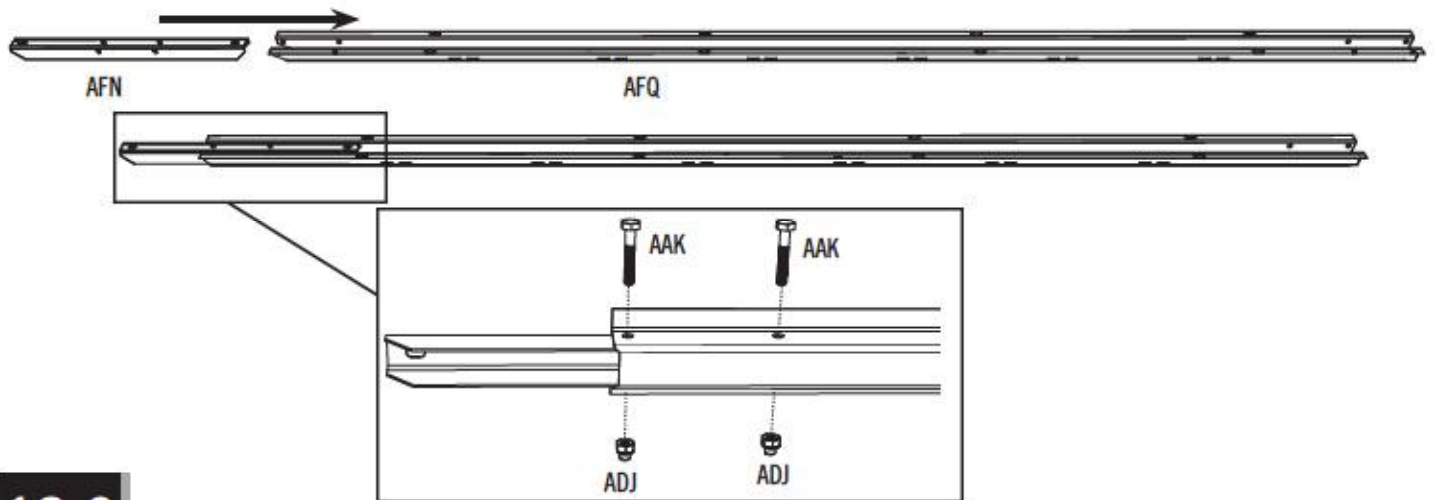

10.3

• Place a **Long Wall Channel Extension (AFJ)** into the top of the Wall Channel. Secure with two (2) **Bolts (AAK)** and two (2) **Cap Nuts (ADJ)**. **Do not overtighten. Repeat this step.**

• Insérer un **rallonge long pour le support mural (AFJ)** dans l'extrémité supérieure du support mural. Attacher-le au support à l'aide de deux (2) **boulons (AAK)** et deux (2) **écrous à chape (ADJ)**. **Ne pas trop serrer. Répéter cette étape.**

• Colocar una **extensión larga para el soporte mural (AFJ)** dentro del extremo superior del soporte mural. Sujetarla usando dos (2) **pernos (AAK)** y dos (2) **tuercas ciegas (ADJ)**. **No apretar demasiado. Repetir este paso.**

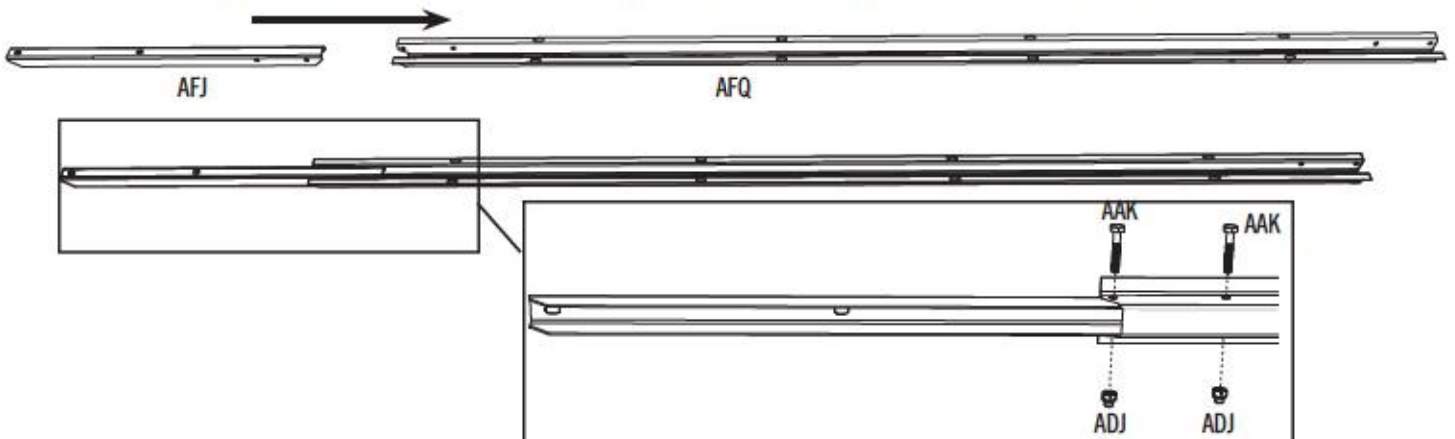

► SECTION 10 (CONTINUED) / SECTION 10 (SUITE) / SECCIÓN 10 (CONTINUACIÓN)

TOOLS AND HARDWARE REQUIRED / OUTILS ET QUINCAILLERIE REQUIS / INSTRUMENTAL Y HERRAJE REQUERIDOS



7/16 in/po (x2)
(11 mm (x2))

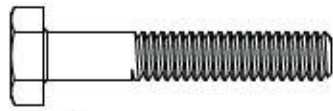

AAK (x4)

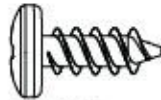

ADZ (x32)



ADJ (x4)



AHT (x4)

10.4

- Secure a **Floor Bracket (AHT)** to the bottom of the Wall Channel using one (1) **Bolt (AAK)** and one (1) **Cap Nut (ADJ)**. **Do not overtighten. Repeat this step three times.**
- Attacher **support de plancher (AHT)** à l'extrémité inférieure du support mural à l'aide d'un (1) **boulon (AAK)** et un (1) **écrou à chape (ADJ)**. **Ne pas trop serrer. Répéter cette étape trois fois.**
- Sujetar un **soporte del piso (AHT)** al extremo inferior del soporte mural usando un (1) **perno (AAK)** y una (1) **tuerca ciega (ADJ)**. **No apretar demasiado. Repetir este paso tres veces.**

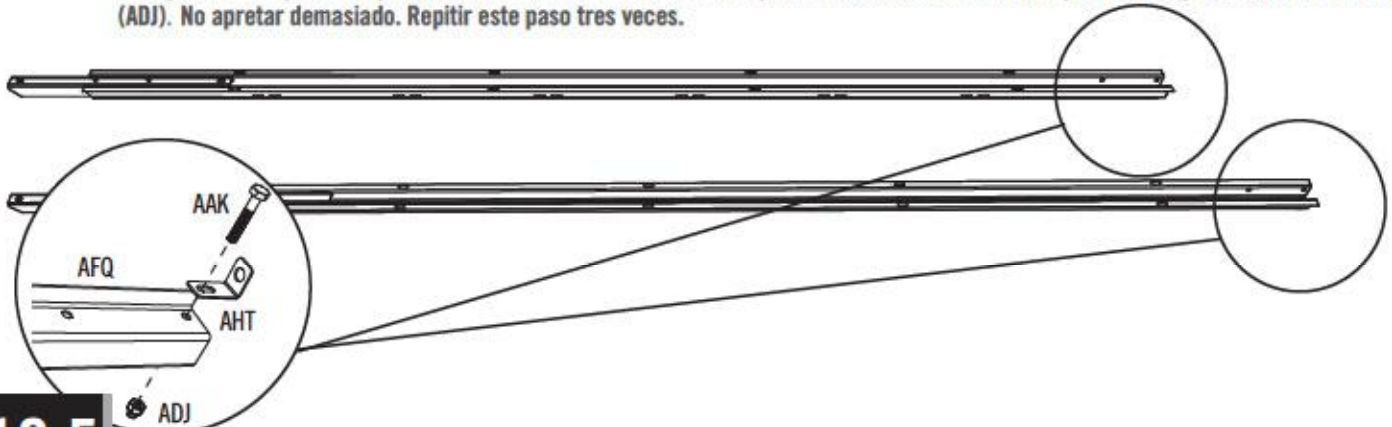

10.5

REAR WALL PANELS / PANNEAUX MURAUX ARRIÈRES / PANELES MURALES TRASEROS



- Secure a Wall Support Channel (with a Short Extension) to each of the rear, corner Wall Panels as shown. **Do not overtighten.**
- Secure a Wall Support Channel (with a Long Extension) to each of the rear, center Wall Panels as shown. **Do not overtighten.**
- Attacher un support mural (avec un rallonge court) à chaque panneau mural arrière latéral comme illustré. **Ne pas trop serrer.** Attacher un support mural (avec un rallonge long) à chaque panneau mural arrière central comme illustré. **Ne pas trop serrer.**
- Sujetar un soporte mural (con una extensión corta) a cada panel mural trasero lateral como se muestra. **No apretar demasiado.** Sujetar un soporte mural (con una extensión larga) a cada panel mural trasero central como se muestra. **No apriete demasiado.**

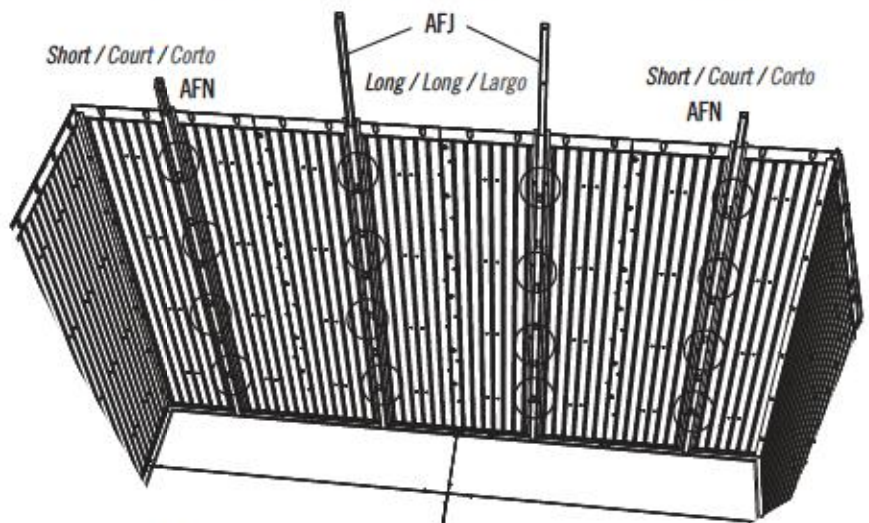



MODELS / MODÈLES / MODELOS 60187 (11' (3,4 m)), 60136 (18.5' (5,6 m)), 60137 (21' (6,4 m))



PARTS IDENTIFIER / IDENTIFICATEUR DE PIÈCES / IDENTIFICADOR DE PIEZAS

CONTENTS OF BOX 1 / CONTENU DE LA BOÎTE 1 / CONTENIDO DE LA CAJA 1

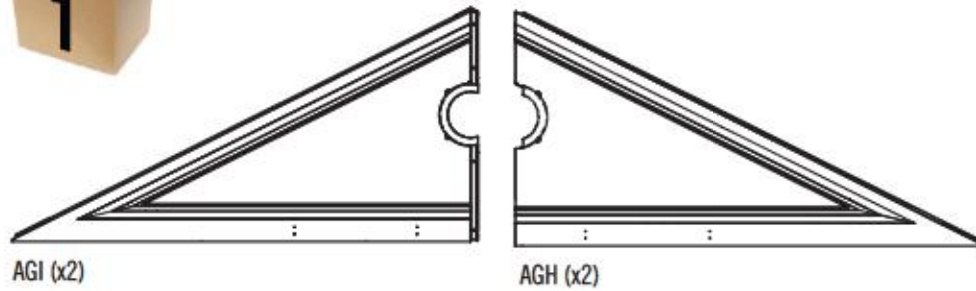

AGI (x2)

AGH (x2)

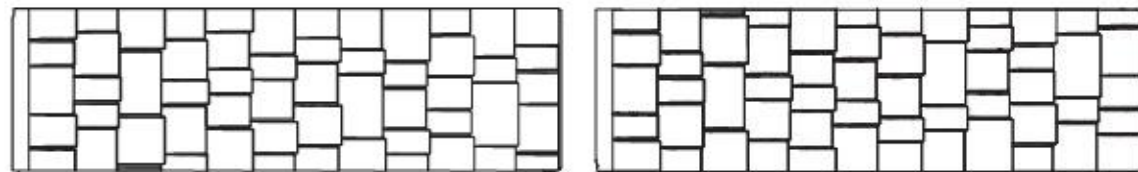

AGU (x2)

AGV (x2)



AGS (x2)

AGT (x2)

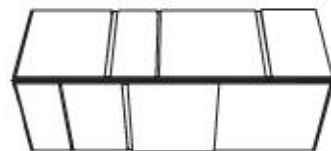

AGE (x2)

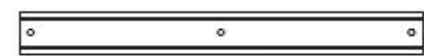

26 1/4 in/po (66,7 cm)

AFB (x8)

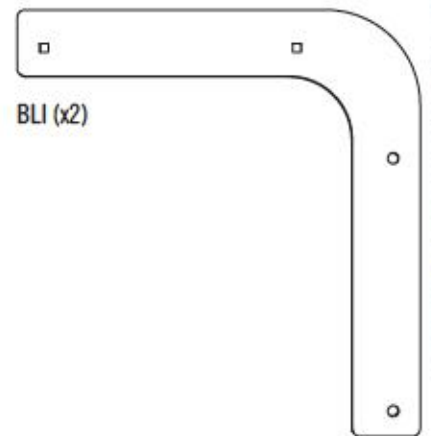

BLI (x2)

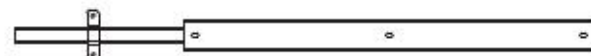

BLG (x1)



AFT (x2)

Remove This Section / Enlevez cette section / Retire esta sección

CONTENTS METAL KIT 1 / CONTENU DU KIT DE PIÈCES EN MÉTAL 1 / CONTENIDO DEL KIT DE PIEZAS DE METAL 1

EZR

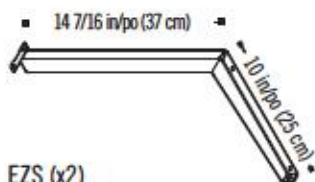

EZS (x2)



MODELS / MODÈLES / MODELOS 60187 (11' (3,4 m)), 60136 (18.5' (5,6 m)), 60137 (21' (6,4 m))



PARTS IDENTIFIER / IDENTIFICATEUR DE PIÈCES / IDENTIFICADOR DE PIEZAS

CONTENTS METAL KIT 2 / CONTENU DU KIT DE PIÈCES EN MÉTAL 2 / CONTENIDO DEL KIT DE PIEZAS DE METAL 2



BLK (x2)



EVA (x1)



CONTENTS METAL KIT 3 / CONTENU DU KIT DE PIÈCES EN MÉTAL 3 / CONTENIDO DEL KIT DE PIEZAS DE METAL 3



AFQ (x6)



AFJ (x2)

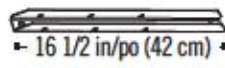

AFN (x2)

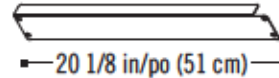

AFP (x2)



AFH (x2)



AFG (x1)



AFC (x2)



BLL (x1)

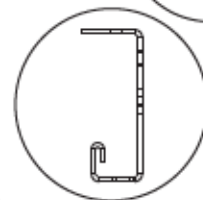

BLN (x1)

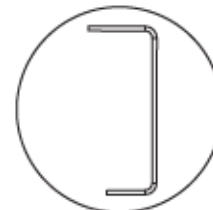

Remove This Section / Enlevez cette section / Retire esta sección



MODELS / MODÈLES / MODELOS 60187 (11' (3,4 m)), 60136 (18.5' (5,6 m)), 60137 (21' (6,4 m))



PARTS IDENTIFIER / IDENTIFICATEUR DE PIÈCES / IDENTIFICADOR DE PIEZAS

CONTENTS METAL KIT 3 / CONTENU DU KIT DE PIÈCES EN MÉTAL 3 / CONTENIDO DEL KIT DE PIEZAS DE METAL 3

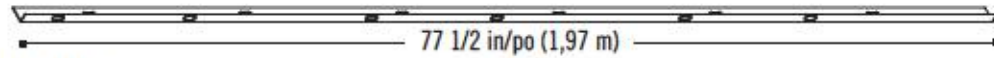
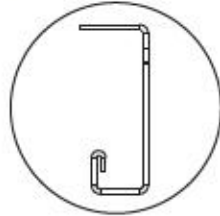
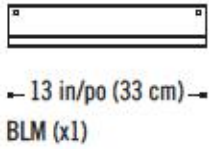

AFR (x2)



CONTENTS OF BOX 2 / CONTENU DE LA BOÎTE 2 / CONTENIDO DE LA CAJA 2

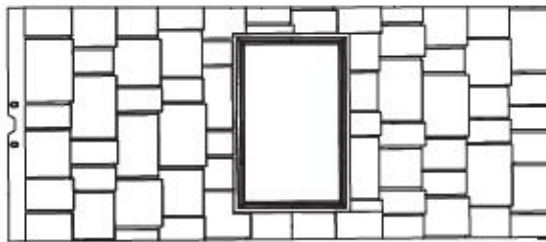

AHB (x1)

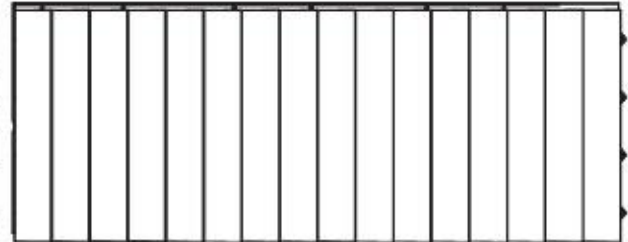

AHD (x3)

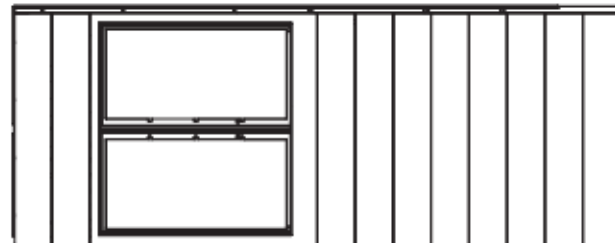

AHH (x1)



AGJ (x4)

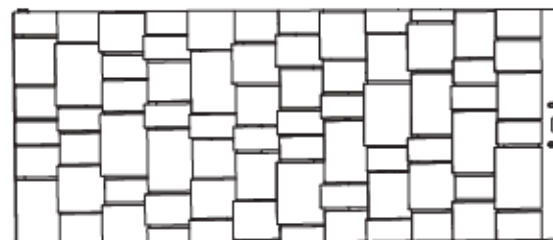

AGQ (x3)

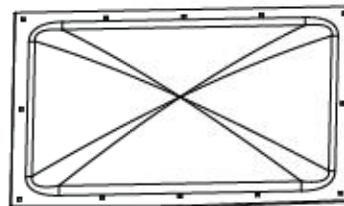

AGB (x1)

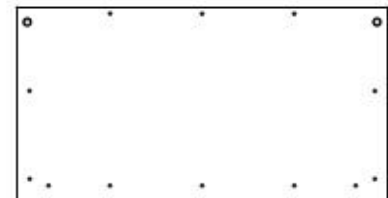

AHF (x2)



AFL (x12)

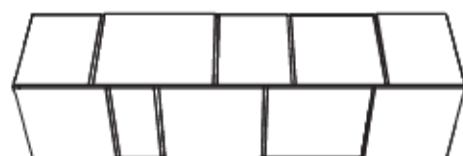

AFY (x2)

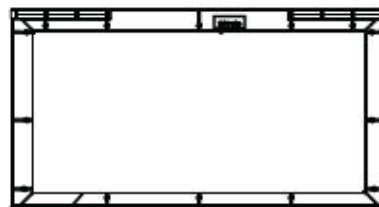

AHG (x2)

Remove This Section / Enlevez cette section / Retire esta sección



MODELS / MODÈLES / MODELOS 60187 (11' (3,4 m)), 60136 (18.5' (5,6 m)), 60137 (21' (6,4 m))



PARTS IDENTIFIER / IDENTIFICATEUR DE PIÈCES / IDENTIFICADOR DE PIEZAS

CONTENTS METAL KIT 4 / CONTENU DU KIT DE PIÈCES EN MÉTAL 4 / CONTENIDO DEL KIT DE PIEZAS DE METAL 4

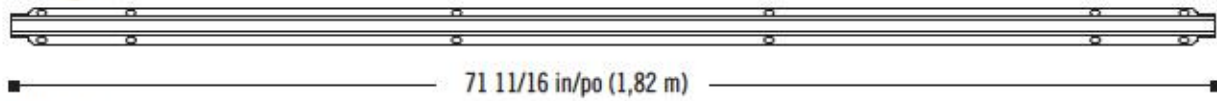

AFH (x4)



AFG (x2)

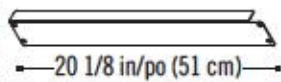

AFP (x4)

Remove This Section / Enlevez cette section / Retire esta sección

CONTENTS METAL KIT 5 / CONTENU DU KIT DE PIÈCES EN MÉTAL 5 / CONTENIDO DEL KIT DE PIEZAS DE METAL 5



AFQ (x4)

HARDWARE BAGS / SACS DE QUINCAILLERIE / BOLSAS DE HERRAJE



CONTENTS OF BOX 3 / CONTENU DE LA BOÎTE 3 / CONTENIDO DE LA CAJA 3

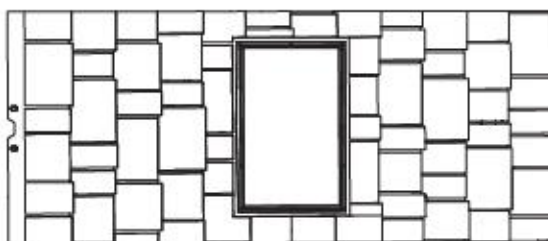

AHB (x1)

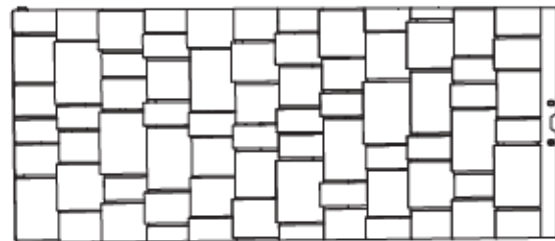

AGQ (x1)



MODELS / MODÈLES / MODELOS 60187 (11' (3,4 m)), 60136 (18.5' (5,6 m)), 60137 (21' (6,4 m))



PARTS IDENTIFIER / IDENTIFICATEUR DE PIÈCES / IDENTIFICADOR DE PIEZAS

CONTENTS OF BOX 3 / CONTENU DE LA BOÎTE 3 / CONTENIDO DE LA CAJA 3

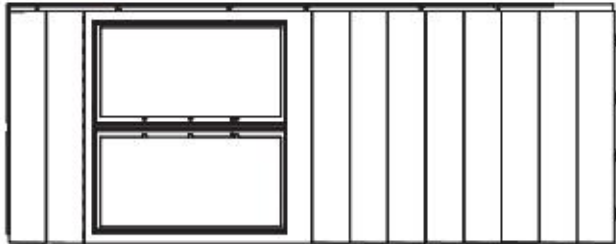

AHH (x1)



AHD (x1)



AGJ (x2)

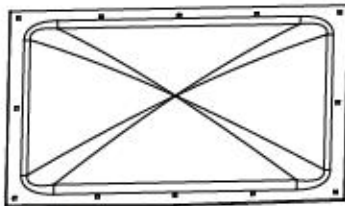

AGB (x1)

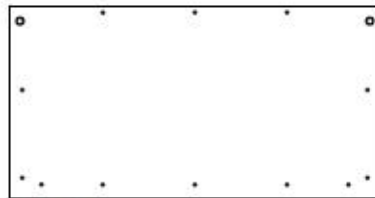

AHF (x2)

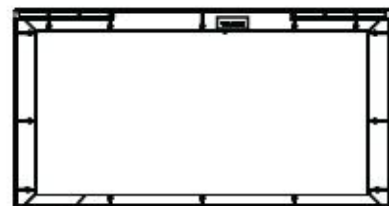

AHG (x2)

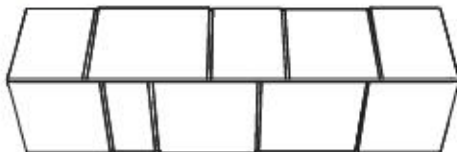

AFY (x1)



AFL (x6)

HARDWARE BAGS / SACS DE QUINCAILLERIE / BOLSAS DE HERRAJE



Remove This Section / Enlevez cette section / Retire esta sección



MODELS / MODÈLES / MODELOS 60187 (11' (3,4 m)), 60136 (18.5' (5,6 m)), 60137 (21' (6,4 m))



PARTS IDENTIFIER / IDENTIFICATEUR DE PIÈCES / IDENTIFICADOR DE PIEZAS

CONTENTS METAL KIT 6 / CONTENU DU KIT DE PIÈCES EN MÉTAL 6 / CONTENIDO DEL KIT DE PIEZAS DE METAL 6



AFH (x2)

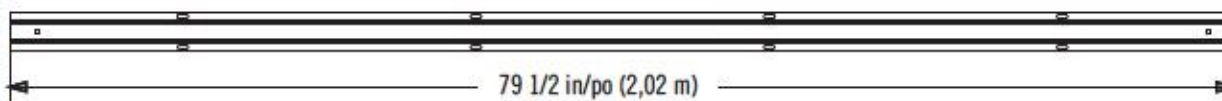

AFG (x1)



CONTENTS METAL KIT 7 / CONTENU DU KIT DE PIÈCES EN MÉTAL 7 / CONTENIDO DEL KIT DE PIEZAS DE METAL 7



AFQ (x2)

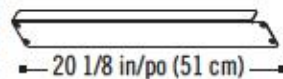

AFP (x2)

CONTENTS OF BOX 4 / CONTENU DE LA BOÎTE 4 / CONTENIDO DE LA CAJA 4

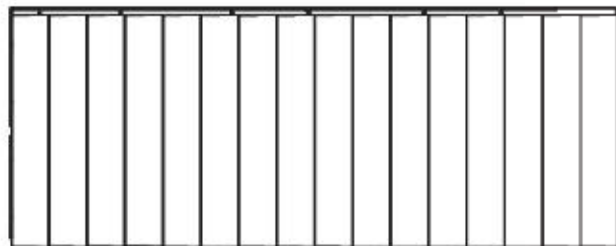

AHD (x6)

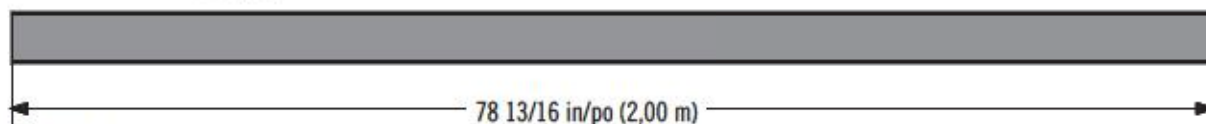

AQX (x4)

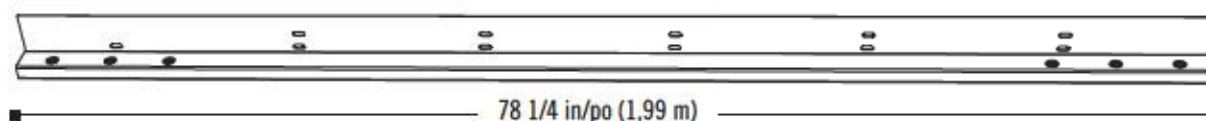

BLJ (x2)



Remove This Section / Enlevez cette section / Retire esta sección



MODELS / MODÈLES / MODELOS 60187 (11' (3,4 m)), 60136 (18.5' (5,6 m)), 60137 (21' (6,4 m))



PARTS IDENTIFIER / IDENTIFICATEUR DE PIÈCES / IDENTIFICADOR DE PIEZAS

CONTENTS OF SMALL PARTS BOX / CONTENIDO DE LA CAJA DE PIEZAS PEQUEÑAS / CONTENU DE LA BOÎTE DE PETITES PIÈCES

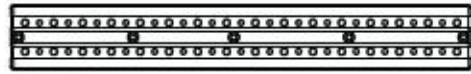

AFU (x2)



AIZ (x4)



AHA (x2)



AIX (x4)

HARDWARE BAGS / SACS DE QUINCAILLERIE / BOLSAS DE HERRAJE



CONTENTS OF BOX 5 / CONTENU DE LA BOÎTE 5 / CONTENIDO DE LA CAJA 5

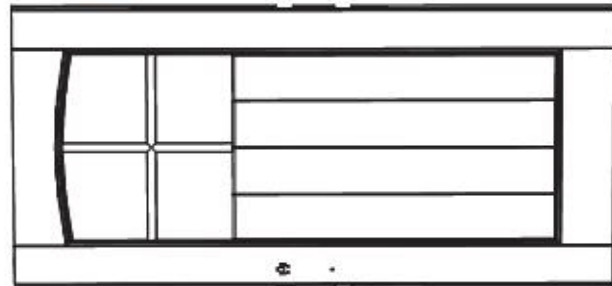

AGZ (x2)

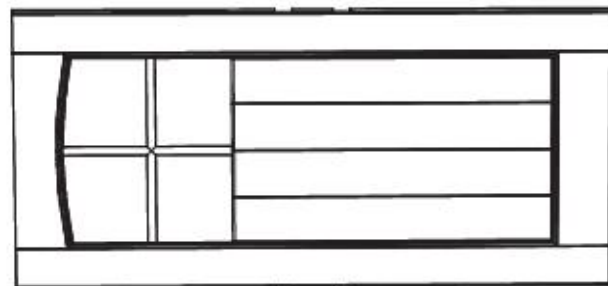

AGO (x1)

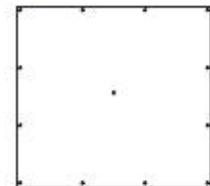

BLO (x3)

Remove This Section / Enlevez cette section / Retire esta sección



MODEL / MODÈLE / MODELO 0125 (60136 (18.5' (5,6 m)))



PARTS IDENTIFIER / IDENTIFICATEUR DE PIÈCES / IDENTIFICADOR DE PIEZAS

Metal Parts / Pièces en métal / Piezas de metal

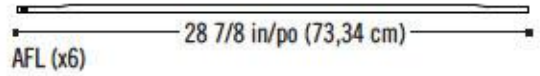

AFL (x6)



AFH (x2)

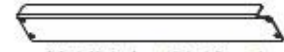

AFP (x2)



AFG (x1)

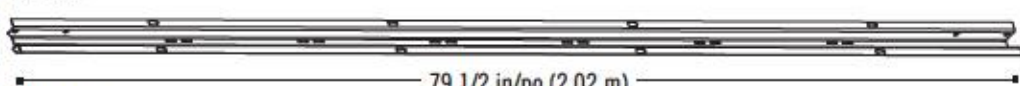

AFQ (x2)



Remove This Section / Enlevez cette section / Retire esta sección

Plastic Parts / Piezas de plástico / Pièces en plastique

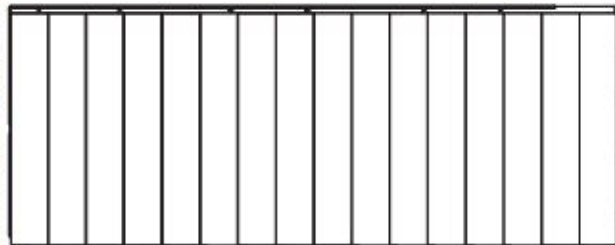

AHD (x2)

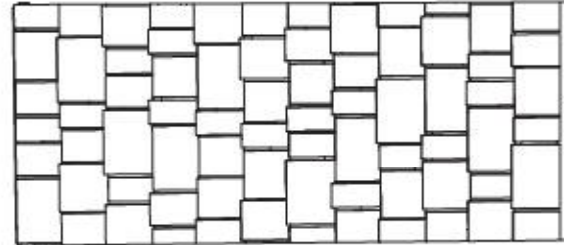

AGQ (x2)

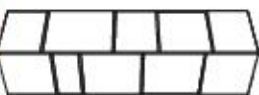

AFY (x1)



AGJ (x2)



HARDWARE BAGS / SACS DE QUINCAILLERIE / BOLSAS DE HERRAJE

Hardware Bags / Sacs de quincaillerie / Bolsas de herraje





MODEL / MODÈLE / MODELO 6426 (60136 (18.5' (5,6 m)))



PARTS IDENTIFIER / IDENTIFICATEUR DE PIÈCES / IDENTIFICADOR DE PIEZAS

Metal Parts / Pièces en métal / Piezas de metal



71 11/16 in/po (1,82 m)

AFH (x4)



79 1/2 in/po(2,02 m)

AFG (x2)

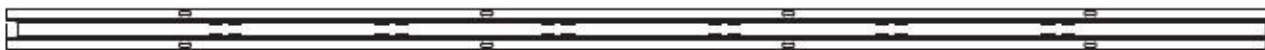

79 1/2 in/po(2,02 m)

AFQ (x4)



20 1/8 in/po (51,12 cm)

AFP (x4)

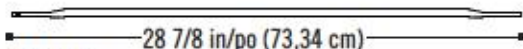

28 7/8 in/po (73,34 cm)

AFL (x12)



HARDWARE BAGS / SACS DE QUINCAILLERIE / BOLSAS DE HERRAJE

Hardware Bags / Sacs de quincaillerie / Bolsas de herraje



Remove This Section / Enlevez cette section / Retire esta sección



MODEL / MODÈLE / MODELO 6426 (x1) (60136 (21' (5,6 m)))



PARTS IDENTIFIER / IDENTIFICATEUR DE PIÈCES / IDENTIFICADOR DE PIEZAS

Plastic Parts / Piezas de plástico / Pièces en plastique

Remove This Section / Enlevez cette section / Retire esta sección

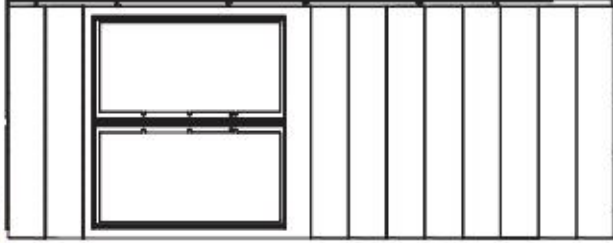

AHH (x2)

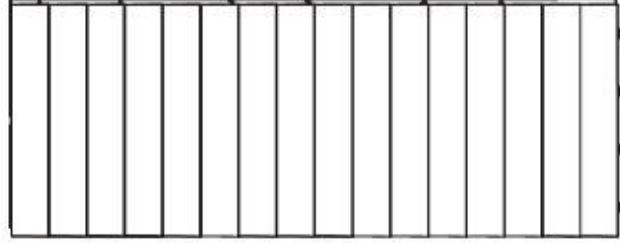

AHD (x2)

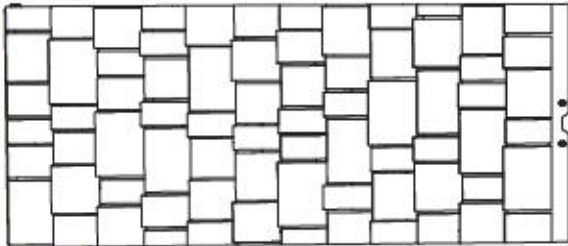

AGQ (x4)



AGJ (x4)

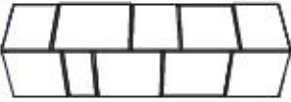

AFY (x2)

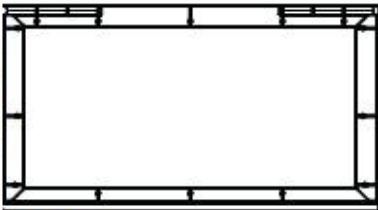

AHG (x4)

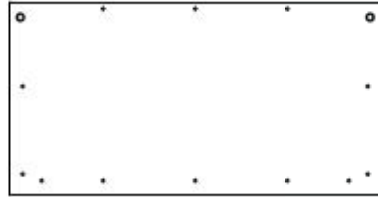

AHF (x4)



MODEL / MODÈLE / MODELO 6426 (x2) (60137 (18.5' (6,4 m)))



PARTS IDENTIFIER / IDENTIFICATEUR DE PIÈCES / IDENTIFICADOR DE PIEZAS

Metal Parts / Pièces en métal / Piezas de metal



71 11/16 in/po (1,82 m)

AFH (x4)



79 1/2 in/po(2,02 m)

AFG (x2)



79 1/2 in/po(2,02 m)

AFQ (x4)



20 1/8 in/po (51,12 cm)

AFP (x4)

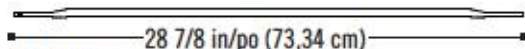

28 7/8 in/po (73,34 cm)

AFL (x12)



HARDWARE BAGS / SACS DE QUINCAILLERIE / BOLSAS DE HERRAJE

Hardware Bags / Sacs de quincaillerie / Bolsas de herraje



Remove This Section / Enlevez cette section / Retire esta sección



MODEL / MODÈLE / MODELO 6426 (x2) (60137 (18.5' (6,4 m)))



PARTS IDENTIFIER / IDENTIFICATEUR DE PIÈCES / IDENTIFICADOR DE PIEZAS

Plastic Parts / Piezas de plástico / Pièces en plastique

Remove This Section / Enlevez cette section / Retire esta sección

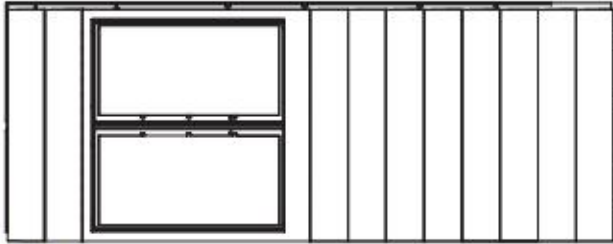

AHH (x2)

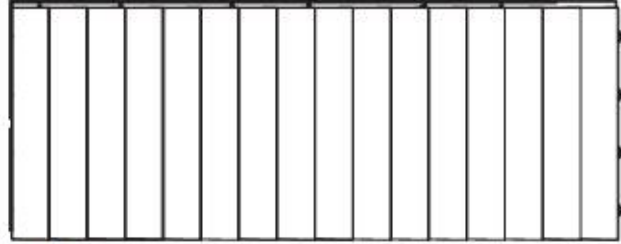

AHD (x2)

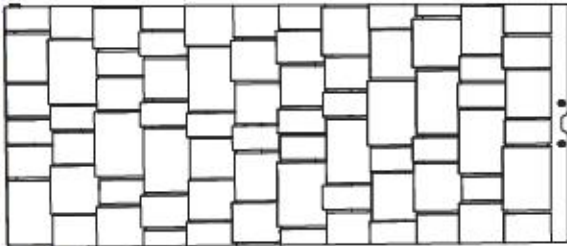

AGQ (x4)



AGJ (x4)



AFY (x2)

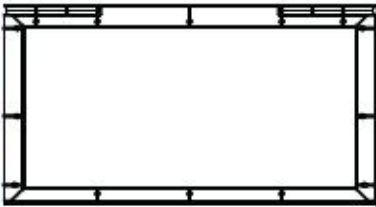

AHG (x4)

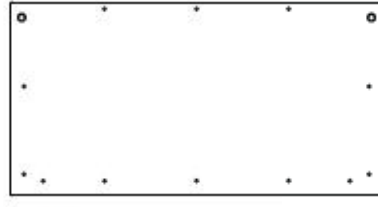

AHF (x4)

11

SHELF INSTALLATION / INSTALLATION DU RAYONNAGE / INSTALACIÓN DE LA ESTANTERÍA



HARDWARE REQUIRED / QUINCAILLERIE REQUISE / HERRAJE REQUERIDO

Hardware Bags / Sacs de quincaillerie / Bolsas de herraje



ADX (x8)



AEE (x8)



PARTS REQUIRED / PIÈCES REQUISES / PIEZAS REQUERIDAS

Metal Parts / Pièces en métal / Piezas de metal



AIZ (x4)

Plastic Parts / Pièces en plastique / Piezas de plástico



AFT (x2)



TOOLS REQUIRED / OUTILS REQUIS / INSTRUMENTAL REQUERIDO



► SECTION 11 (CONTINUED) / SECTION 11 (SUITE) / SECCIÓN 11 (CONTINUACIÓN)

TOOLS AND HARDWARE REQUIRED / OUTILS ET QUINCAILLERIE REQUIS / INSTRUMENTAL Y HERRAJE REQUERIDOS



AIZ (x4)



ADX (x8)

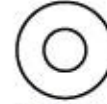

AEE (x8)

11.1

14 in/po x 30 in/po (36,6 cm x 76,2 cm) (AFT)

- Decide where you would like to place your 14" (36,6 cm) Shelves. Insert two **Shelf Brackets (AIZ)** into opposite slots in the Shelf Support Channels as shown.
- Décider où placer les étagères de 36,6 cm (14 po). Insérer deux **équerres (AIZ)** dans les fentes opposées dans les canaux de support comme illustré.
- Decidir donde colocar los estantes de 36,6 cm (14 in.). Insertar dos **escuadras (AIZ)** en las ranuras opuestas en los canales de soporte como se muestra.

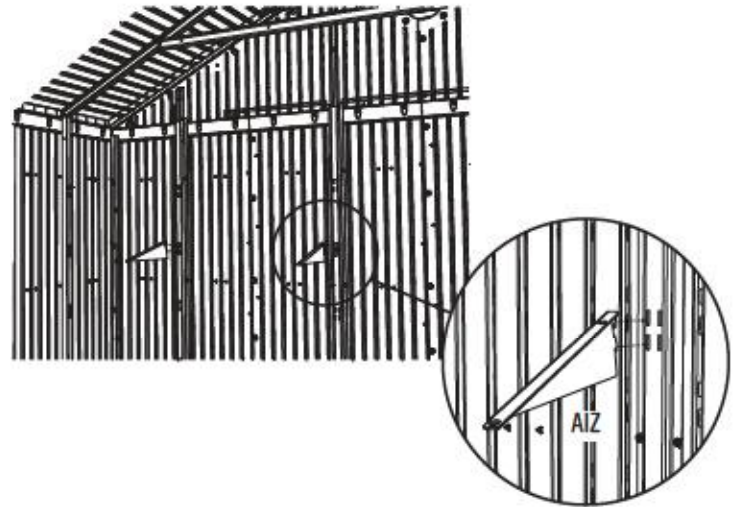

11.2

- Attach a **Shelf (AFT)** to the Shelf Brackets using the hardware indicated. **Repeat steps 11.1–11.2 for the remaining Shelf.**
- Attacher une **étagère (AFT)** aux équerres à l'aide de la quincaillerie indiquée. **Répéter les étapes 11.1 – 11.2 pour l'étagère restante.**
- Sujetar un **estante (AFT)** a las escuadras usando el herraje indicado. **Repetir los pasos 11.1–11.2 para el estante restante.**

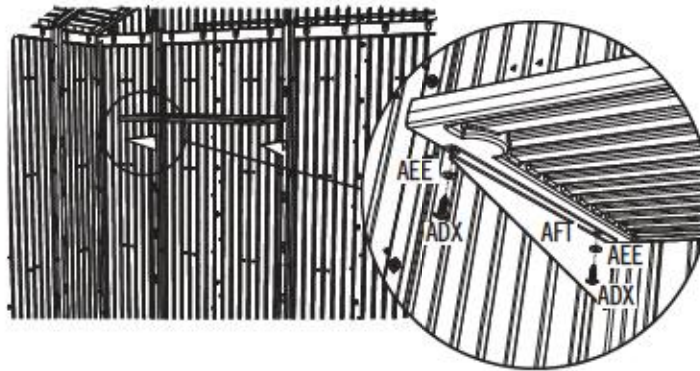



HARDWARE REQUIRED / QUINCAILLERIE REQUISE / HERRAJE REQUERIDO

Hardware Bag / Sac de quincaillerie / Bolsa de herraje

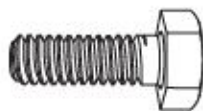

BBL (x6)



BQP (x12)



AAV (x2)



AEB (x14)



BBG (x1)

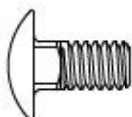

ACA (x12)



ADJ (x26)

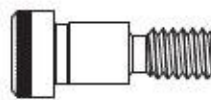

BBF (x2)



AID (x1)



ADX (x4)

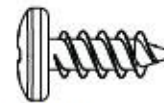

ADZ (x17)



EVB (x6)



BBE (x2)

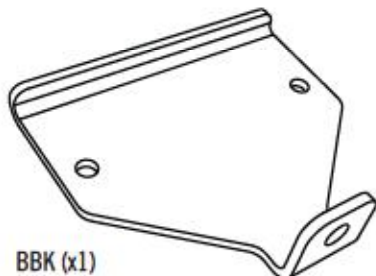

BBK (x1)

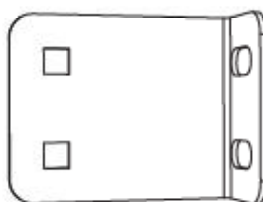

CJR (x2)



BBJ (x1)

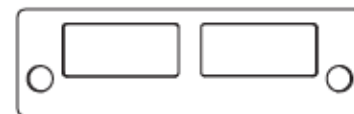

EZL (x2)



PARTS REQUIRED / PIÈCES REQUISES / PIEZAS REQUERIDAS

Metal Parts / Pièces en métal / Piezas de metal

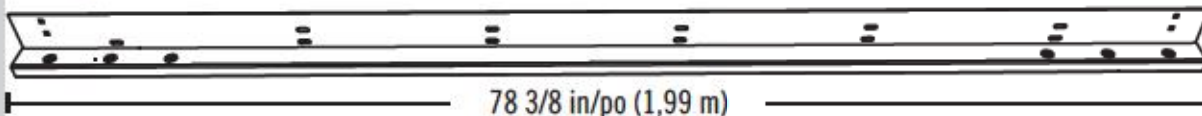

BLJ (x2)

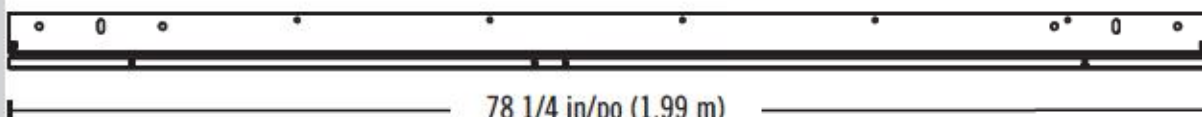

BLK (x2)



12

DOOR-TO-DOOR FRAME ASSEMBLY / ASSEMBLAGE DES PORTES À L'ENCADREMENT / ENSAMBLE DE LAS PUERTAS A LA MARCA



PARTS REQUIRED / PIÈCES REQUISES / PIEZAS REQUERIDAS

Metal Parts / Pièces en métal / Piezas de metal

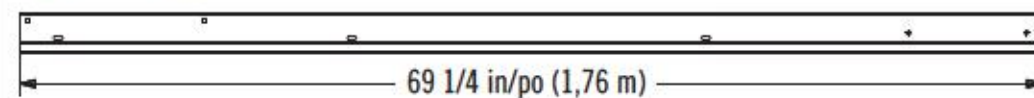

BLL (x1)



• 13 in/po (0,33 m) •

BLM (x1)

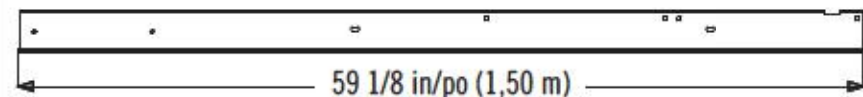
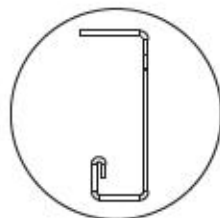

BLN (x1)

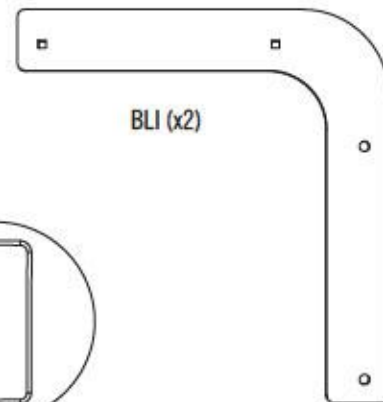
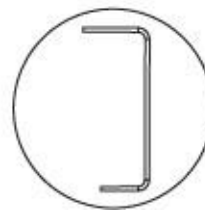

BLI (x2)

Plastic Parts / Pièces en plastique / Piezas de plástico

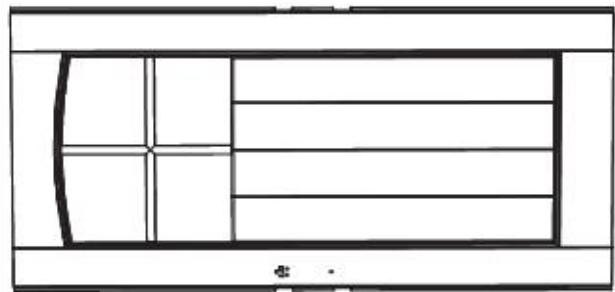

AGZ (x2)

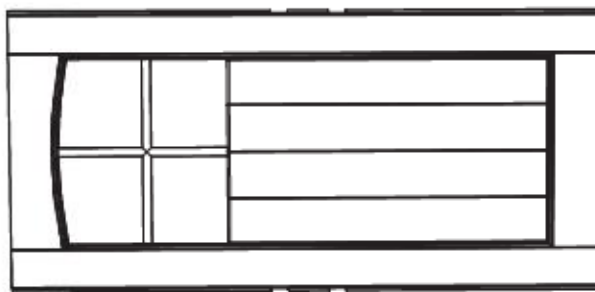

AGO (x1)



TOOLS REQUIRED / OUTILS REQUIS / INSTRUMENTAL REQUERIDO



7/16 in/po (11 mm)



AID (x1)

► SECTION 12 (CONTINUED) / SECTION 12 (SUITE) / SECCIÓN 12 (CONTINUACIÓN)

TOOLS AND HARDWARE REQUIRED / OUTILS ET QUINCAILLERIE REQUIS / INSTRUMENTAL Y HERRAJE REQUERIDOS

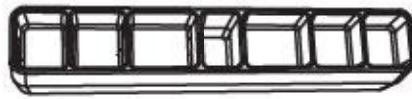

EVB (x2)

12.1



- Insert the **Spacers (EVB)** into the slots on the right side of the back of the **Left Door (AGO)** as shown.
- Insérer les **pièces d'écartement (EVB)** dans les fentes sur le côté droit du dos de la **porte gauche (AGO)** comme illustré.
- Insertar los **espaciadores (EVB)** en las ranuras en el lado derecho del reverso de la **puerta izquierda (AGO)** como se muestra.

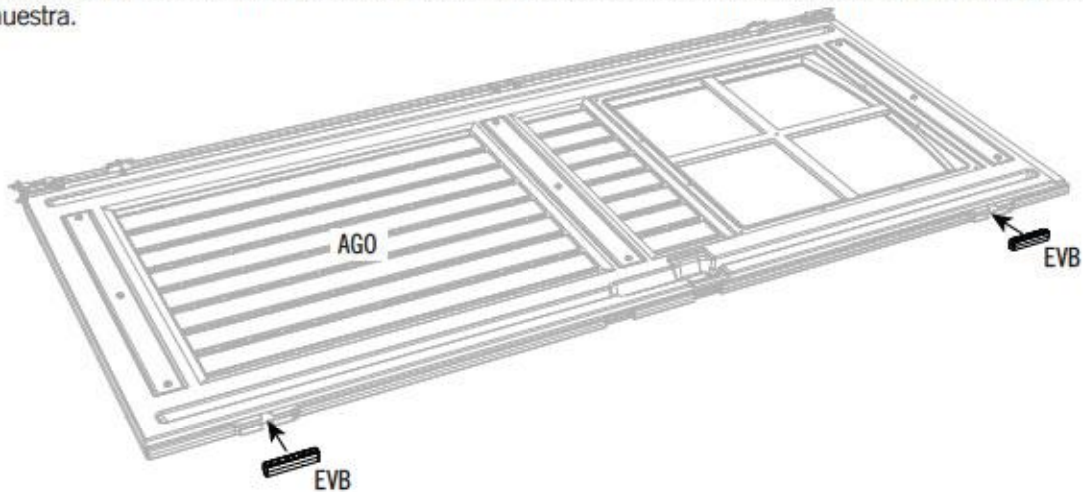

12.2

- Slide a **Door Hinge (BLK)** onto the edge of the **Left Door (AGO)** (The Left Door has no handle). Align the holes in the Hinge with those in the center of the edge of the Door.
- Faire glisser une **charnière de la porte (BLK)** sur le bord de la **porte gauche (AGO)** (La porte gauche n'a pas poignée). Aligner les trous dans la charnière avec ceux du bord de la porte.
- Deslizar una **bisagra para la puerta (BLK)** sobre el borde de la puerta izquierda (AGO) (La puerta izquierda no tiene picaporte). Alinear los agujeros en la bisagra con ellos en el centro del borde de la puerta.

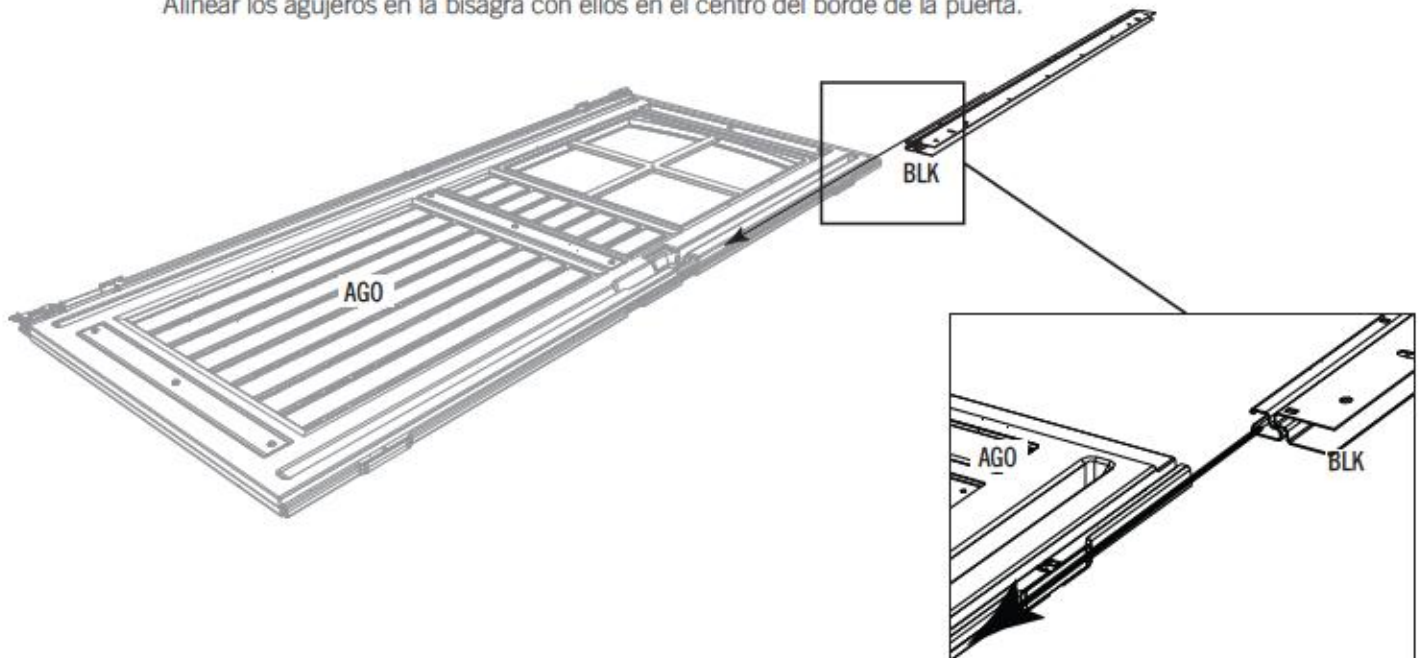

► SECTION 12 (CONTINUED) / SECTION 12 (SUITE) / SECCIÓN 12 (CONTINUACIÓN)

TOOLS AND HARDWARE REQUIRED / OUTILS ET QUINCAILLERIE REQUIS / INSTRUMENTAL Y HERRAJE REQUERIDOS



7/16 in/po
(11 mm)



BQP (x4)



ADJ (x4)



BBL (x3)



AEB (x5)



EVB (x2)

12.3

- Secure the Hinge to the Door with the hardware included.
- Attacher la charnière à la porte à l'aide de la quincaillerie incluse.
- Sujetar la bisagra a la puerta usando el herraje incluido.

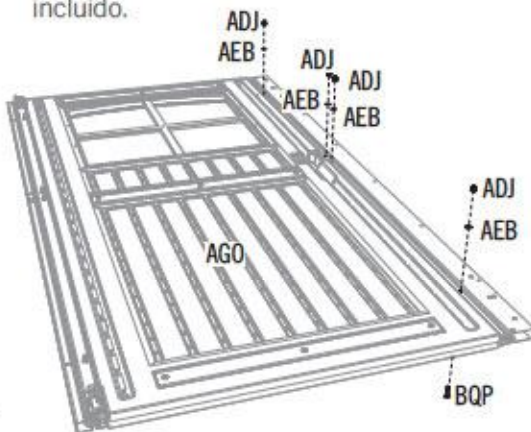

12.4

- Insert the **Left Door Jamb (BLJ)** into the Hinge and align the holes.
- Insérer le **montant gauche (BLJ)** dans la charnière, et aligner les trous.
- Insertar la **jamba izquierda (BLJ)** en la bisagra, y alinear los agujeros.

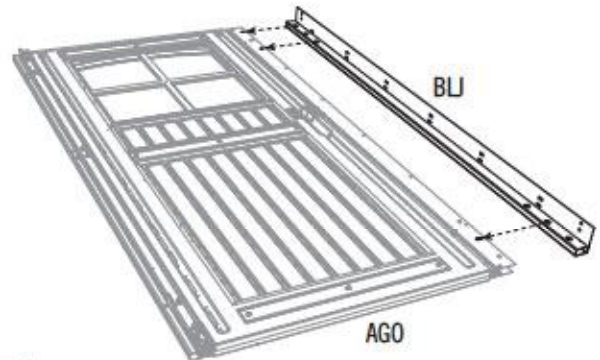

12.5

- Secure the Left Door Jamb and **Angle Bracket (BLI)** to the Door with the hardware provided.
- Attacher le montant gauche et le **support angulaire (BLI)** à la porte à l'aide de la quincaillerie incluse.
- Sujetar la jamba izquierda y el **soporte angular (BLI)** a la puerta usando el herraje incluido.

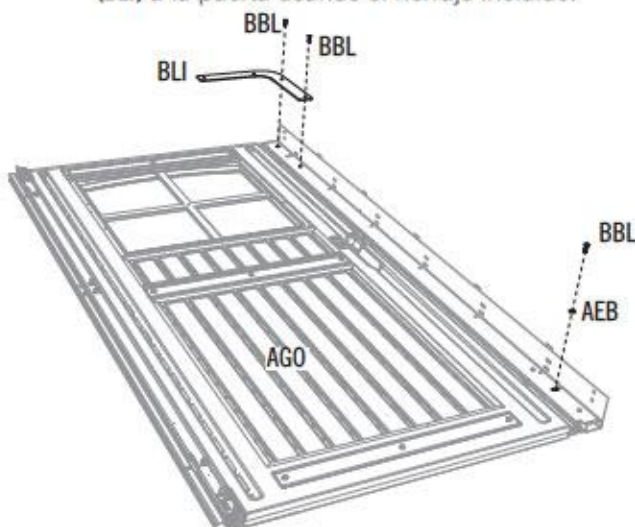

12.6

- Insert the **Spacers (EVB)** into the slots on the right side of the back of the Center Door as shown.
- Insérer les **pièces d'écartement (EVB)** dans les fentes sur le côté droit du dos de la porte centrale comme illustré.
- Insertar los **espaciadores (EVB)** en las ranuras en el lado derecha del reverso de la puerta central como se muestra.

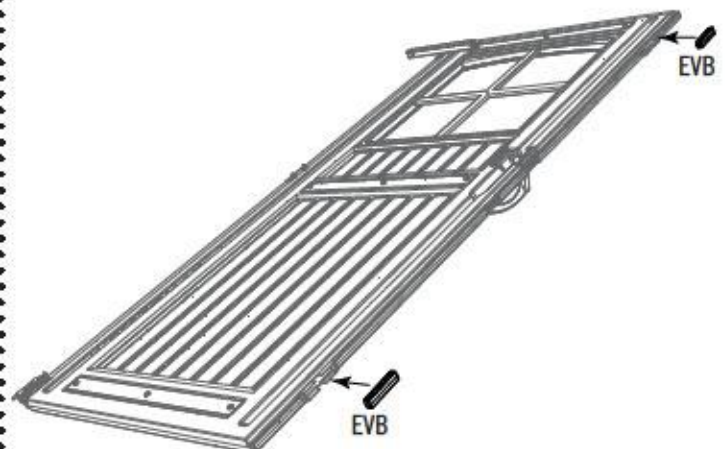

► SECTION 12 (CONTINUED) / SECTION 12 (SUITE) / SECCIÓN 12 (CONTINUACIÓN)

TOOLS AND HARDWARE REQUIRED / OUTILS ET QUINCAILLERIE REQUIS / INSTRUMENTAL Y HERRAJE REQUERIDOS



7/16 in/po
(11 mm)



BBL (x4)



AEB (x4)



BQP (x4)

12.7



- Slide the Center Door down into the Hinge on the Left Door, and align the holes.
- Faire glisser la porte centrale dans la charnière dans la porte gauche, et aligner les trous.
- Deslizar la puerta central dentro de la bisagra en la puerta izquierda, y alinear los agujeros.

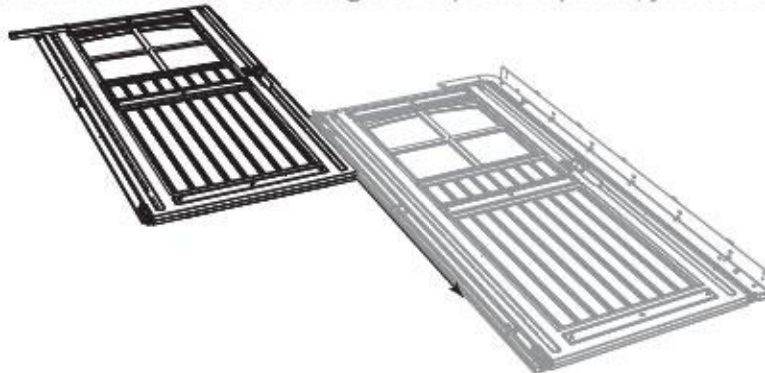

12.8

- Secure the Center Door to the Hinge with the hardware included.
- Attacher la porte centrale à la charnière à l'aide de la quincaillerie incluse.
- Sujetar la puerta central a la bisagra usando el herraje incluido.

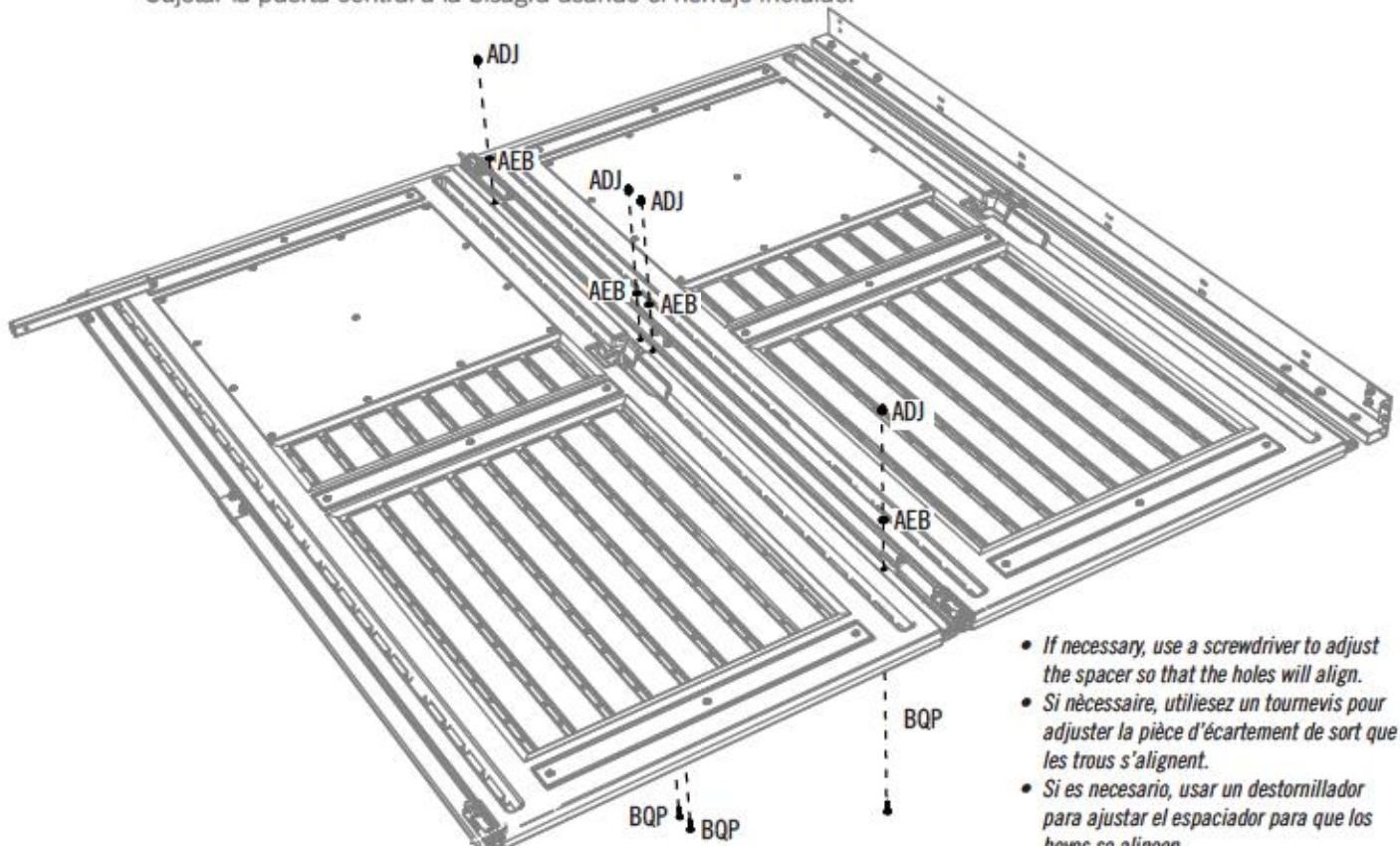

- If necessary, use a screwdriver to adjust the spacer so that the holes will align.
- Si nécessaire, utilisez un tournevis pour ajuster la pièce d'écartement de sorte que les trous s'alignent.
- Si es necesario, usar un destornillador para ajustar el espaciador para que los hoyos se alineen.

► SECTION 12 (CONTINUED) / SECTION 12 (SUITE) / SECCIÓN 12 (CONTINUACIÓN)

TOOLS AND HARDWARE REQUIRED / OUTILS ET QUINCAILLERIE REQUIS / INSTRUMENTAL Y HERRAJE REQUERIDOS



7/16 in/po
(11 mm)



BQP (x4)



ADJ (x4)



AEB (x4)

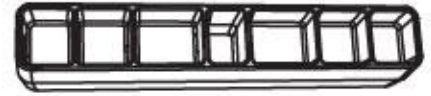

EVB (x2)

12.9



- Insert the **Spacers (EVB)** into the slots on the right side of the back of the Right Door as shown.
- Insérer les **pièces d'écartement (EVB)** dans les fentes sur le côté droit du dos de la porte centrale comme illustré.
- Insertar los **espaciadores (EVB)** en las ranuras en el lado derecha del reverso de la puerta central como se muestra.

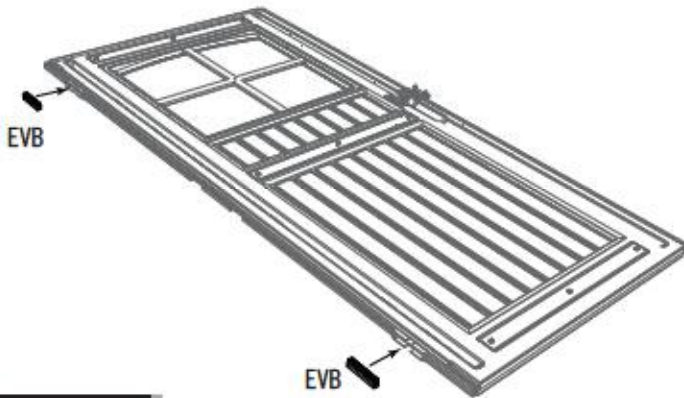

12.10

- Slide a **Door Hinge (BLK)** onto the edge of the Right Door. Align the holes in the Hinge with those in the center of the edge of the Door.
- Faire glisser une **charnière de la porte (BLK)** sur le bord de la porte gauche. Aligner les trous dans la charnière avec ceux du bord de la porte.
- Deslizar una **bisagra para la puerta (BLK)** sobre el borde de la puerta derecha. Alinear los agujeros en la bisagra con ellos en el centro del borde de la puerta.

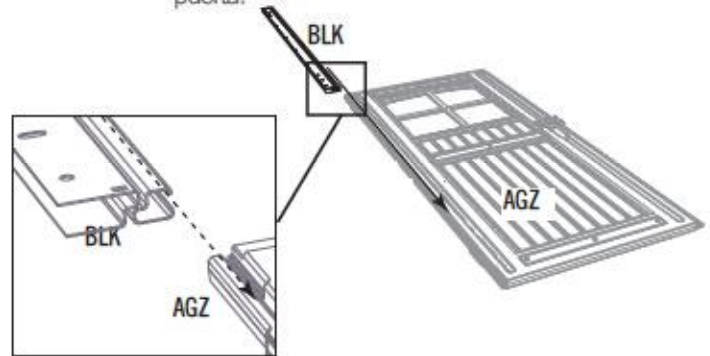

12.11

- Secure the Hinge to the Door with the hardware provided.
- Attacher la charnière à la porte à l'aide de la quincaillerie incluse.
- Sujetar la bisagra a la puerta usando el herraje incluido.

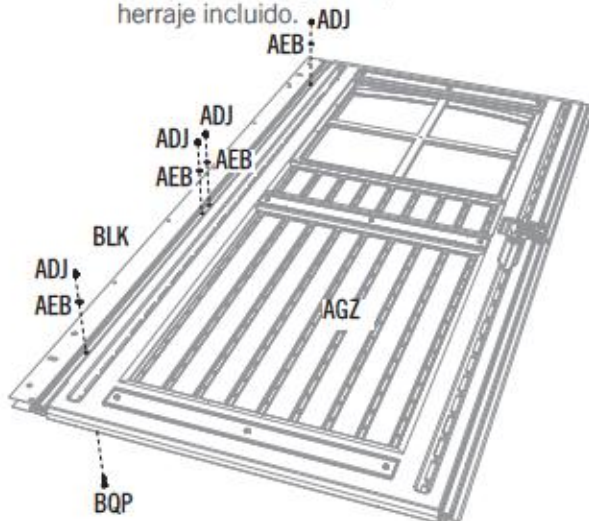

12.12

- Insert the **Right Door Jamb (BLJ)** into the Hinge and align the holes.
- Insérer le **montant droit (BLJ)** dans la charnière, et aligner les trous.
- Insertar la **jamba derecha (BLJ)** en la bisagra, y alinear los agujeros.

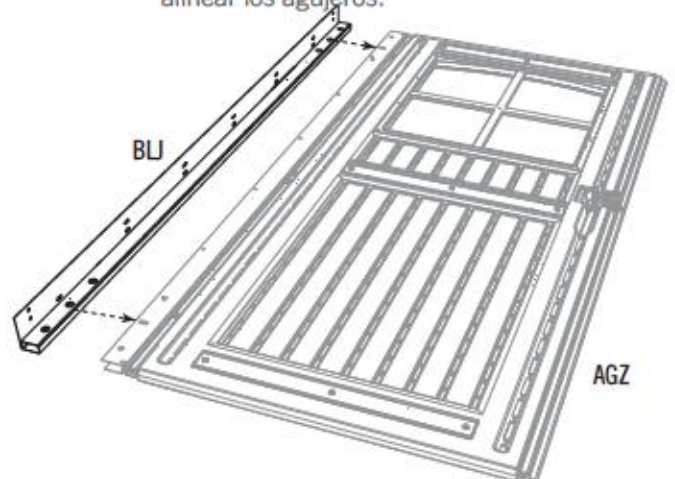

► SECTION 12 (CONTINUED) / SECTION 12 (SUITE) / SECCIÓN 12 (CONTINUACIÓN)

TOOLS AND HARDWARE REQUIRED / OUTILS ET QUINCAILLERIE REQUIS / INSTRUMENTAL Y HERRAJE REQUERIDOS



7/16 in/po (x2)
(11 mm) (x2)

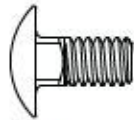

ACA (x2)



ADJ (x2)



BBL (x3)



AEB (x1)

12.13

- Secure the Right Door Jamb and **Angle Bracket (BLI)** to the Door with the hardware provided.
- Attacher le montant droit et le **support angulaire (BLI)** à la porte à l'aide de la quincaillerie incluse.
- Sujetar la jamba derecha y el **soporte angular (BLI)** a la puerta usando el herraje incluido.

- *If necessary, use a screwdriver to adjust the spacer so that the holes will align.*
- *Si nécessaire, utilisez un tournevis pour ajuster la pièce d'écartement de sorte que les trous s'alignent.*
- *Si es necesario, usar un destornillador para ajustar el espaciador para que los hoyos se alineen.*

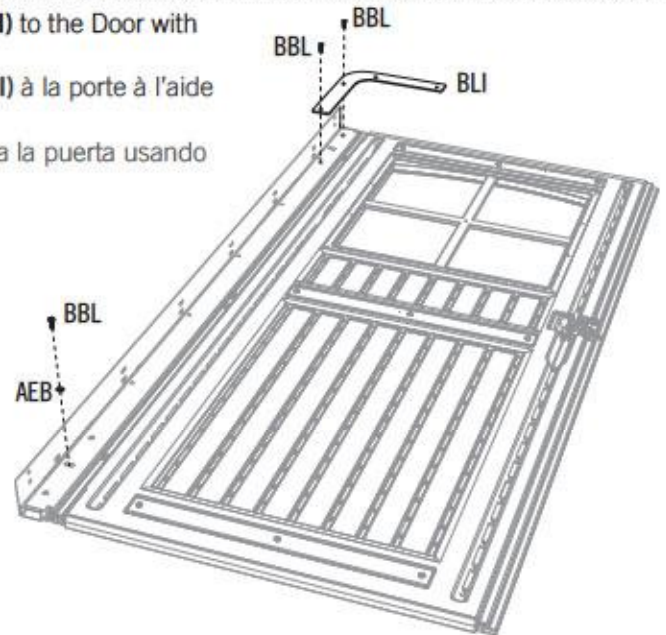

12.14

- Set the **Short Glider Track (BLM)** into the **Glider Channel (BLN)**, align the holes, and secure with the hardware provided.
- Mettre le rail coulissant court (**BLM**) dans le canal coulissant (**BLN**), aligner les trous, et attacher-le à l'aide de la quincaillerie incluse.
- Colocar la **vía corrediza corta (BLM)** dentro del **canal corredizo (BLN)**, alinear los agujeros, y sujetarla con el herraje incluido.

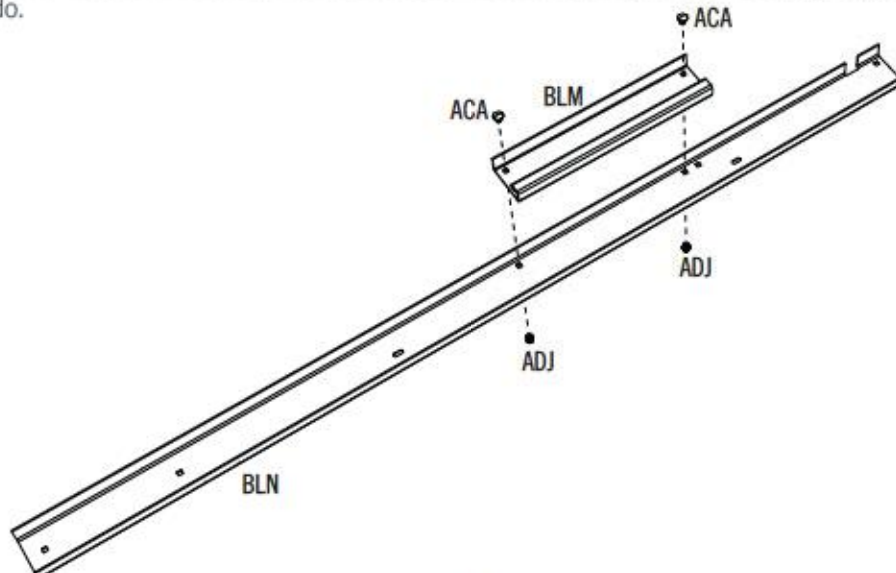

► SECTION 12 (CONTINUED) / SECTION 12 (SUITE) / SECCIÓN 12 (CONTINUACIÓN)

TOOLS AND HARDWARE REQUIRED / OUTILS ET QUINCAILLERIE REQUIS / INSTRUMENTAL Y HERRAJE REQUERIDOS



7/16 in/po (x2)
(11 mm) (x2)

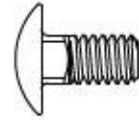

ACA (x2)



ADJ (x2)

12.15

- Slide the Long Glider Track into the Glider Channel, align the holes, and secure with the hardware provided. **Do not overtighten Cap Nuts (ADJ).**
- Faire glisser le rail coulissant dans le canal coulissant, aligner les trous, et attacher-le à l'aide de la quincaillerie incluse. **Ne pas trop serrer les écrous borgnes (ADJ).**
- Deslizar la vía corrediza dentro del canal corredizo, alinear los agujeros, y sujétela usando el herraje incluido. **No apretar demasiado las tuercas ciegas (ADJ).**

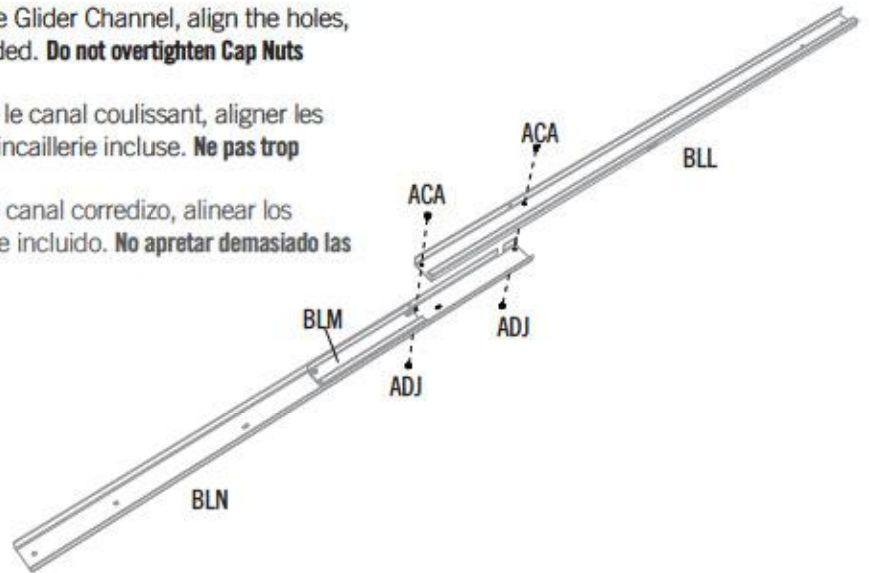

12.16

- Set the Glider Track Assembly onto the two Corner Brackets, and align two holes at each end.
- Mettre l'assemblage du rail coulissant sur les supports angulaires, et aligner les deux trous à chaque extrémité.
- Coloque el conjunto de la vía corrediza sobre los soportes angulares, y alinear los dos agujeros a cada extremo.

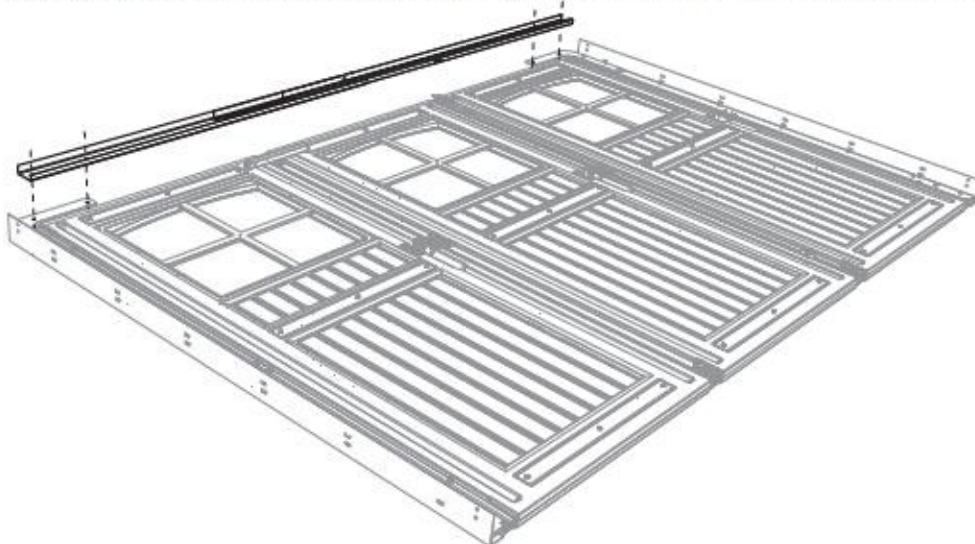

► SECTION 12 (CONTINUED) / SECTION 12 (SUITE) / SECCIÓN 12 (CONTINUACIÓN)

TOOLS AND HARDWARE REQUIRED / OUTILS ET QUINCAILLERIE REQUIS / INSTRUMENTAL Y HERRAJE REQUERIDOS

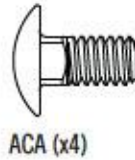
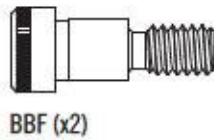
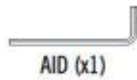
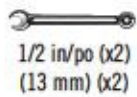

12.17

- Attach the Glider Track Assembly to the Doors using the hardware provided.
- Attacher l'assemblage du rail couissant aux portes à l'aide de la quincaillerie incluse.
- Sujetar el conjunto de la vía corrediza a las puertas usando el herraje incluido.

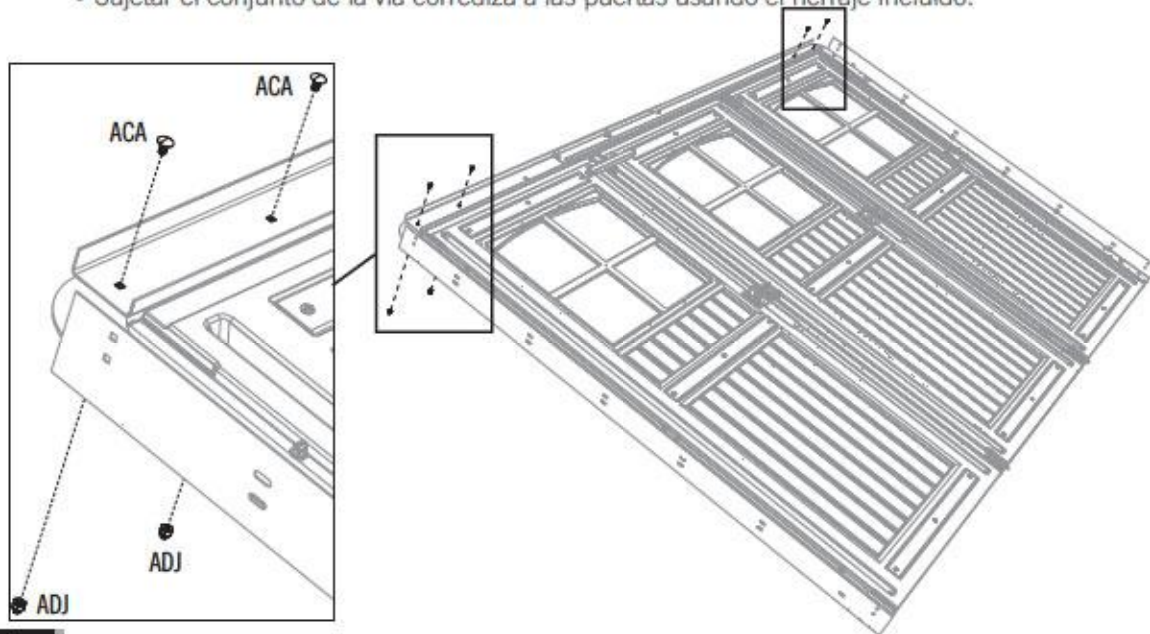

12.18

- Secure the Glider Wheels (BBE) to the Carriage Bracket (BBK) using the hardware provided. **Do not overtighten Cap Nuts (ADJ).**
- Attacher bien les roues coulissantes (BBE) au support couissant (BBK) à l'aide de la quincaillerie incluse. **Ne pas trop serrer les écrous borgnes (ADJ).**
- Sujetar las ruedas corredizas (BBE) al soporte corredizo (BBK) usando el herraje incluido. **No apretar demasiado las tuercas ciegas (ADJ).**

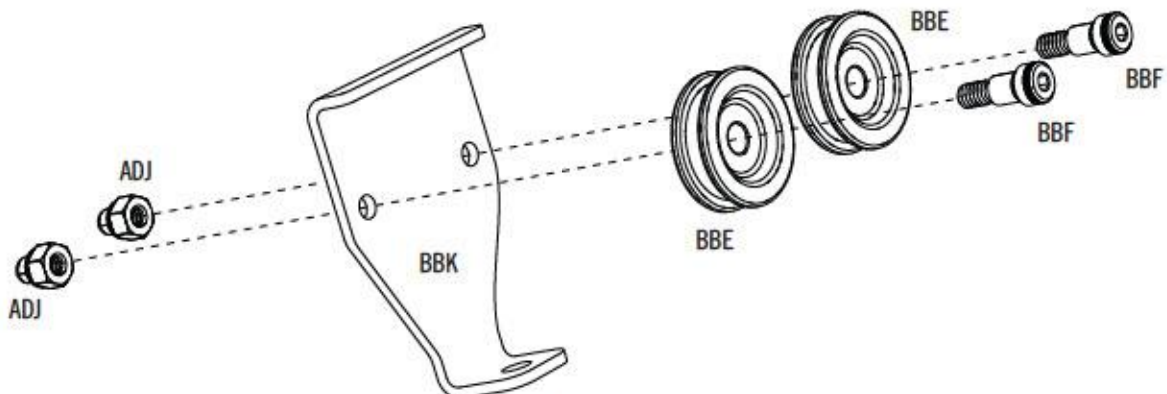

► SECTION 12 (CONTINUED) / SECTION 12 (SUITE) / SECCIÓN 12 (CONTINUACIÓN)

TOOLS AND HARDWARE REQUIRED / OUTILS ET QUINCAILLERIE REQUIS / INSTRUMENTAL Y HERRAJE REQUERIDOS

7/16 in/po
(11 mm)
1/2 in/po (x2)
(13 mm) (x2)



BBG (x1)



AAV (x2)

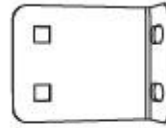

CJR (x2)



ADJ (x4)

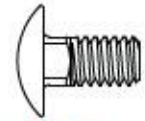

ACA (x4)

12.19

- Set the Glider Wheels onto the Glider Track as shown.
- Mettre les roues coulissantes sur le rail coulissant comme illustré.
- Meter las ruedas corredizas en la vía corrediza como se muestra.

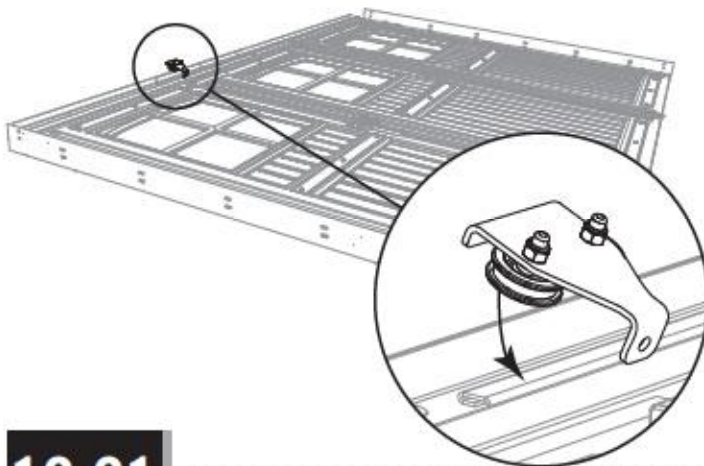

12.20

- Secure the end of the top, center Door Brace to the Carriage Bracket as shown.
- Attacher bien l'extrémité du support supérieur central de la porte au support coulissant comme illustré.
- Sujetar el extremo del soporte superior central de la puerta al soporte corredizo como se muestra.

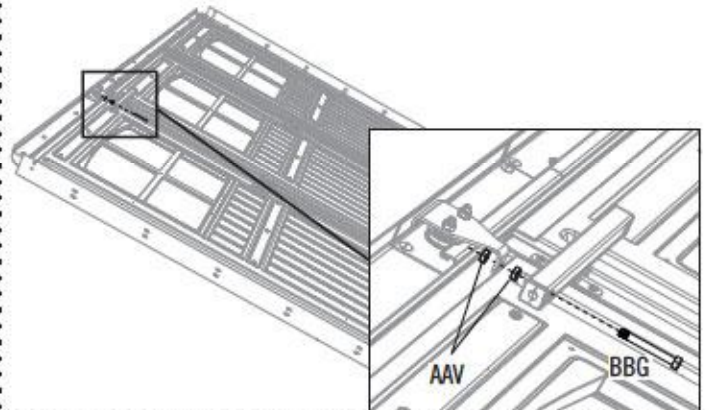

12.21

- Secure a Floor Bracket (CJR) to the Left and Right Door Jambs using the hardware indicated. **Do not overtighten.**
- Attacher bien un support de plancher (CJR) aux montants droit et gauche à l'aide de la quincaillerie indiquée. **Ne pas trop serrer.**
- Sujetar un soporte de piso (CJR) a las jambas derecha e izquierda usando el herraje indicado. **No apretar demasiado.**

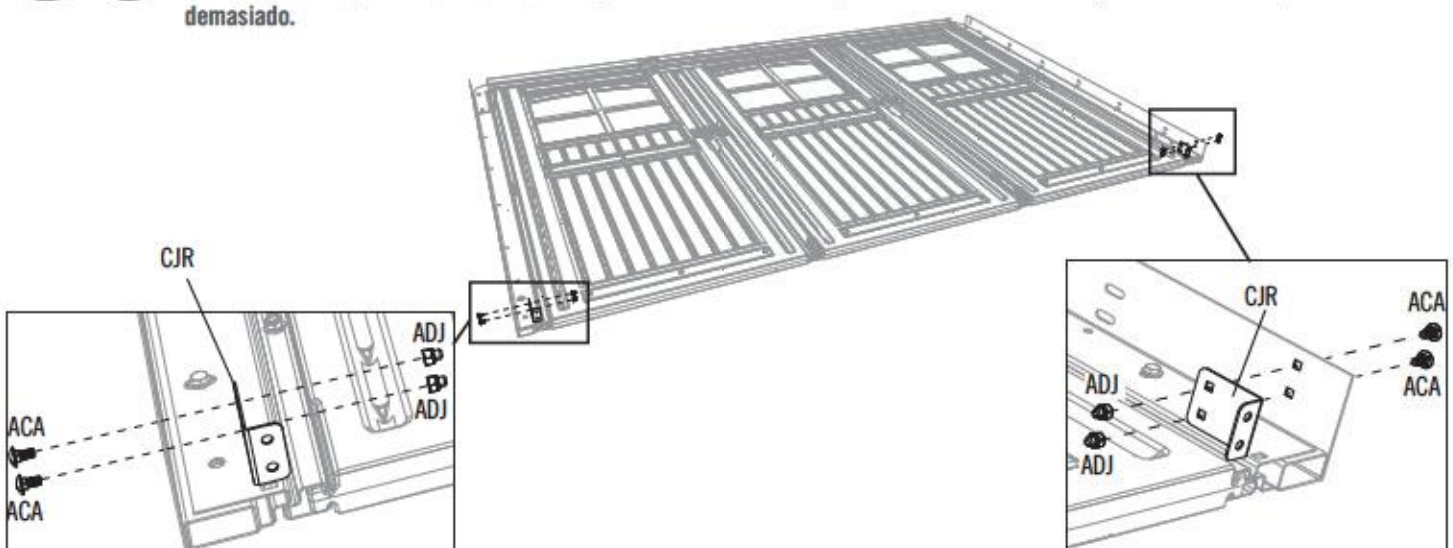

► SECTION 12 (CONTINUED) / SECTION 12 (SUITE) / SECCIÓN 12 (CONTINUACIÓN)

TOOLS AND HARDWARE REQUIRED / OUTILS ET QUINCAILLERIE REQUIS / INSTRUMENTAL Y HERRAJE REQUERIDOS



12.22

- With the help of two adults, one on each side of the Door Frame Assembly and the one with the tools inside the shed, set the bottom of the Door Frame Assembly on the Floor just inside the Shed, and raise the Assembly upright so the edges are flush with the sides of the Wall Panels.
- À l'aide de deux adultes, un de chaque côté de l'assemblage de l'encadrement et un, avec les outils, à l'intérieur de l'abri, mettre le bord inférieur de l'assemblage sur le plancher juste à l'intérieur de l'abri, et lever l'assemblage vertical pour que les bords soient au ras des côtés des panneaux muraux.
- Usando dos adultos, uno en cada lado del conjunto de la marca de las puertas y uno con las herramientas adentro de la caseta, colocar el borde inferior del conjunto de la marca de las puertas en el piso justo tras la puerta, y levantar el conjunto vertical para que los bordes estén al ras con los lados de los paneles murales.

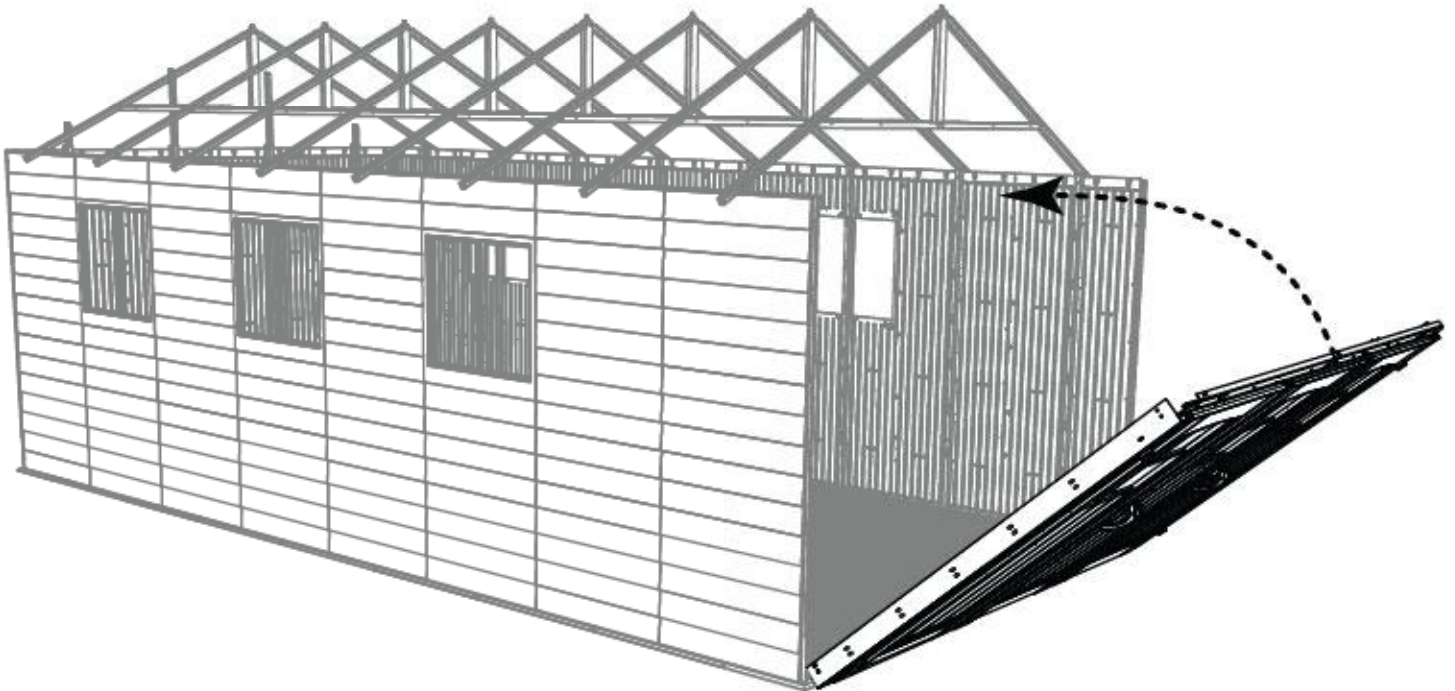

► SECTION 12 (CONTINUED) / SECTION 12 (SUITE) / SECCIÓN 12 (CONTINUACIÓN)

TOOLS AND HARDWARE REQUIRED / OUTILS ET QUINCAILLERIE REQUIS / INSTRUMENTAL Y HERRAJE REQUERIDOS

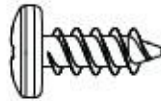

ADZ (x11)

12.23

- Reinsert the five (5) **Screws (ADZ)** connecting one Hinge to the right side of the shed and the six (6) **Screws (ADZ)** connecting the second hinge do the left side of the shed.
- Réinsérer les cinq (5) **vis (ADZ)** qui attachent une charnière au côté droit de l'abri et les six (6) **vis (ADZ)** qui attachent la deuxième charnière au côté gauche de l'abri.
- Reinsertar los cinco (5) **tornillos (ADZ)** que sujetan una bisagra al lado derecho de la caseta y los seis (6) **tornillos (ADZ)** que sujetan la segunda bisagra al lado izquierdo de la caseta.

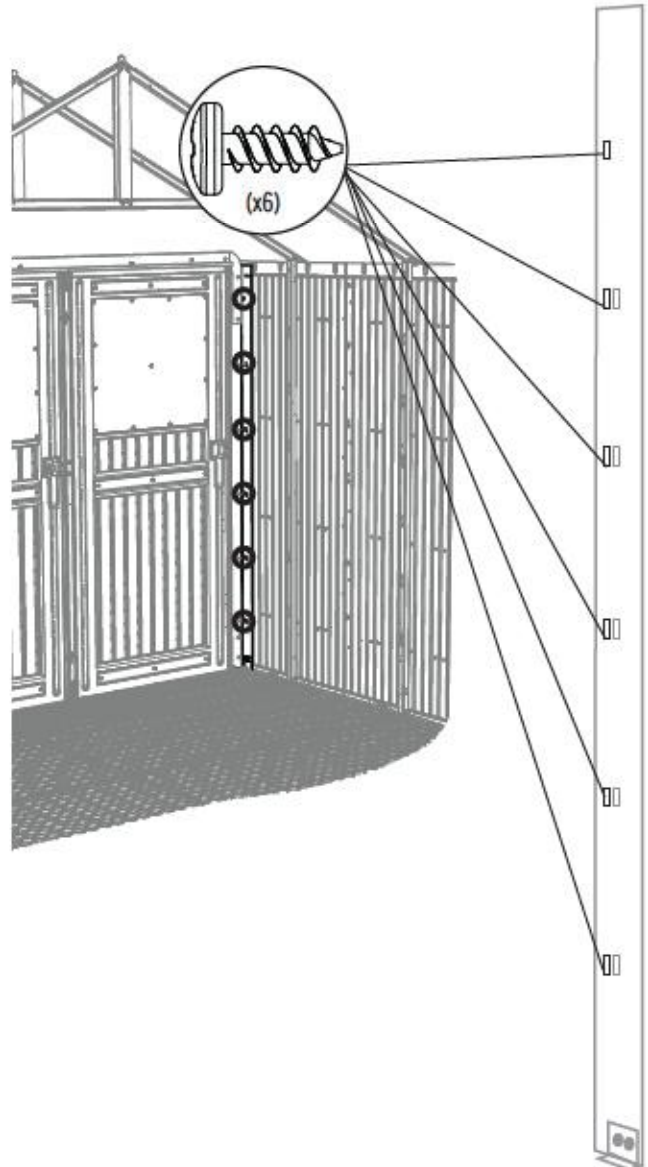
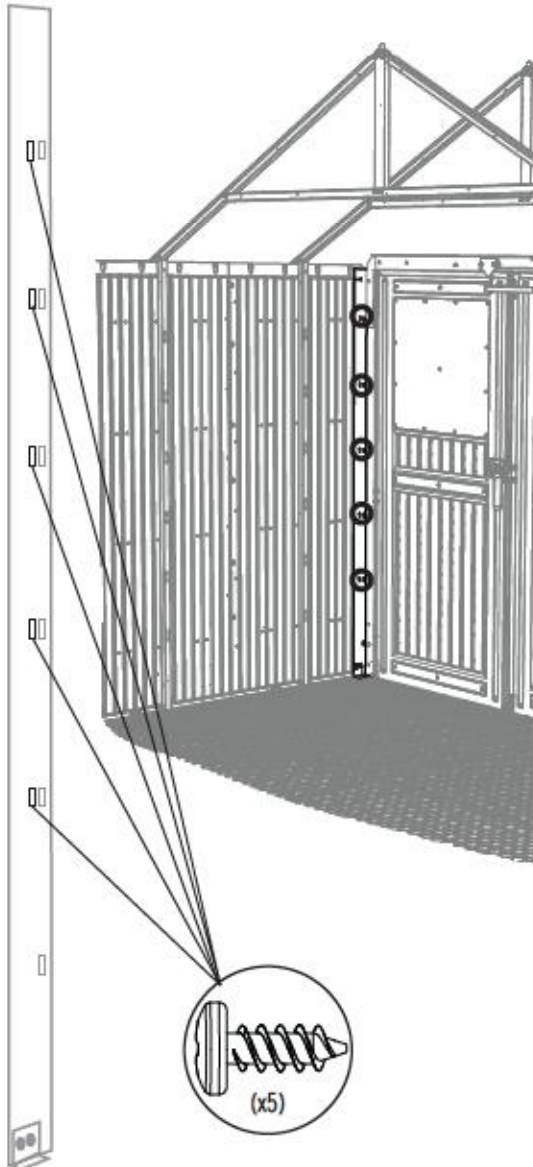

► SECTION 12 (CONTINUED) / SECTION 12 (SUITE) / SECCIÓN 12 (CONTINUACIÓN)

TOOLS AND HARDWARE REQUIRED / OUTILS ET QUINCAILLERIE REQUIS / INSTRUMENTAL Y HERRAJE REQUERIDOS

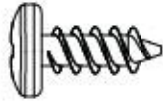

ADZ (x4)

12.24

- Insert two (2) **Screws (ADZ)** through each of the two Floor Brackets and into the Floor as shown.
- Insérer deux (2) **vis (ADZ)** à travers chaque un des deux supports de plancher et dans le plancher comme illustré.
- Insertar dos (2) **tornillos (ADZ)** por cada uno de los soportes de piso y adentro del piso como se muestra.

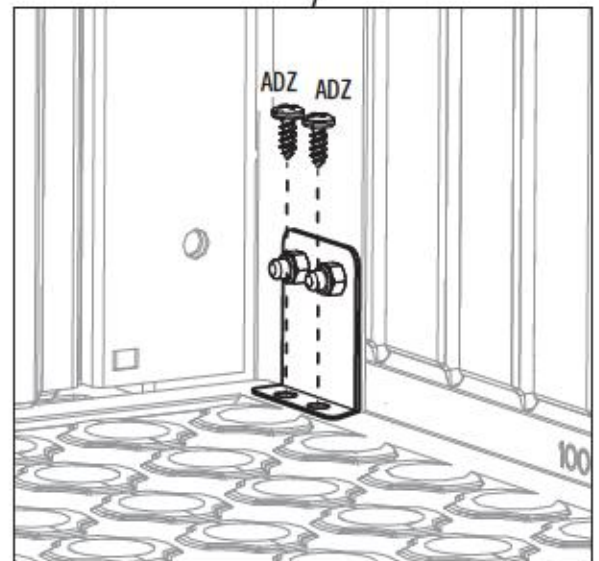
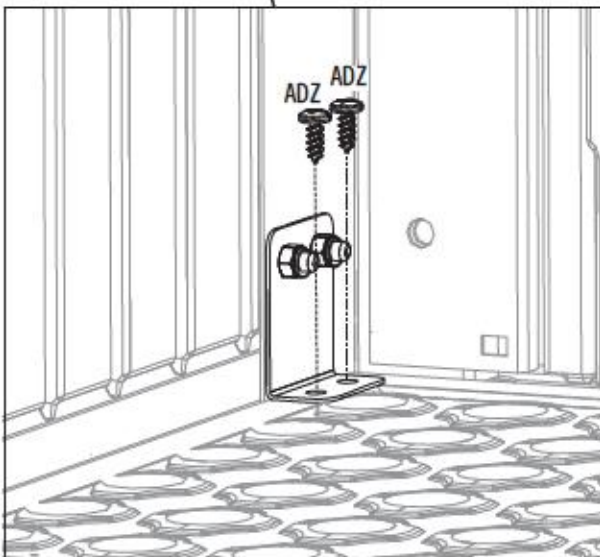
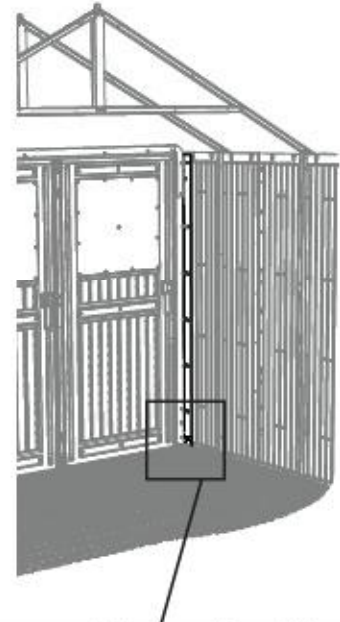
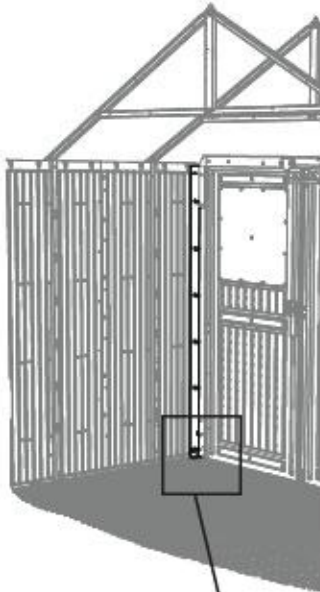

► SECTION 12 (CONTINUED) / SECTION 12 (SUITE) / SECCIÓN 12 (CONTINUACIÓN)

TOOLS AND HARDWARE REQUIRED / OUTILS ET QUINCAILLERIE REQUIS / INSTRUMENTAL Y HERRAJE REQUERIDOS

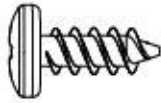

ADZ (x2)



ADX (x4)



EZL (x2)



BBJ (x1)

12.25

- Open the Doors, and secure the two **Short Strike Plates (EZL)** and the **Long Strike Plate (BBJ)** to the Floor at the locations shown. **After attaching the Small Strike Plates, you may need to cut out the plastic for the holes in the Floor under the Small Strike Plates.**
- Ouvrir les portes, et attacher bien les deux **gâches courtes (EZL)** et la **gâche longue (BBJ)** au plancher aux endroits indiqués. **Après avoir attaché les gâches courtes, il pourra être nécessaire de couper le plastique pour les trous sous les gâches courtes.**
- Abrir las puertas, y sujetar las dos **placas de refuerzo (EZL)** y la **placa de refuerzo larga (BBJ)** al piso a las ubicaciones indicadas. **Después de sujetar las placas de refuerzo cortas, puede ser necesario de cortar el plástico para los agujeros en el piso debajo las placas de refuerzo cortas.**

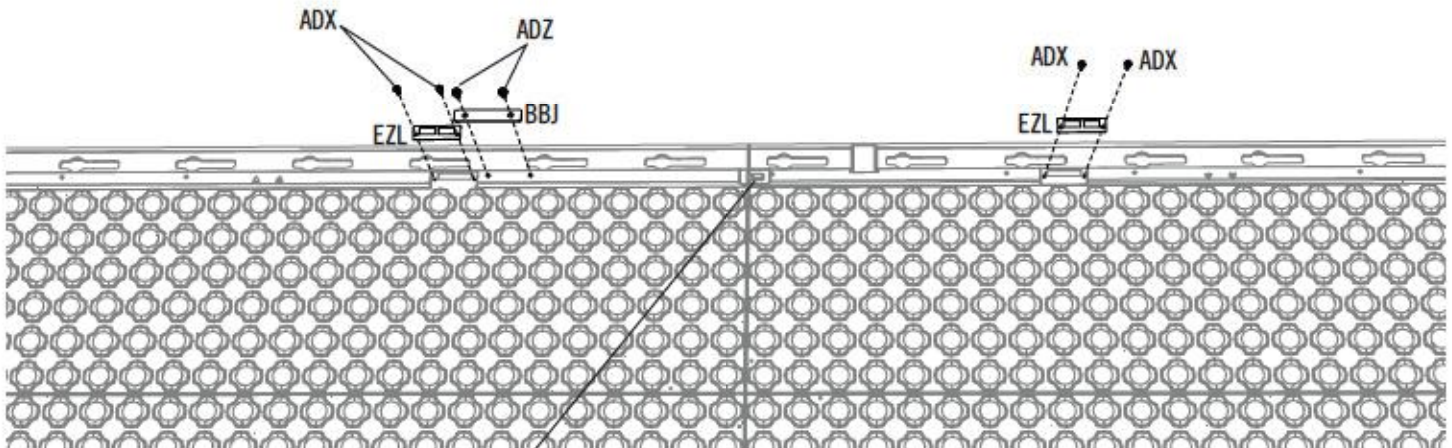

- *No Strike Plate goes here in these models.*
- *Il n'y a pas de gâche ici dans ces modèles.*
- *No hay una placa de refuerzo aquí en estos modelos.*

13

TRIM INSTALLATION / INSTALLATION DES MOULURES / INSTALACIÓN DE LAS MOLDURAS



HARDWARE REQUIRED / QUINCAILLERIE REQUISE / HERRAJE REQUERIDO

Hardware Bag / Sac de quincaillerie / Bolsa de herraje



ADX (x34)



ACK (x4)

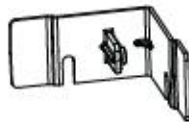

AGA (x12)

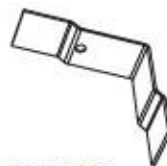

BMH (x10)



PARTS REQUIRED / PIÈCES REQUISES / PIEZAS REQUERIDAS

Plastic Parts / Pièces en plastique / Piezas de plástico

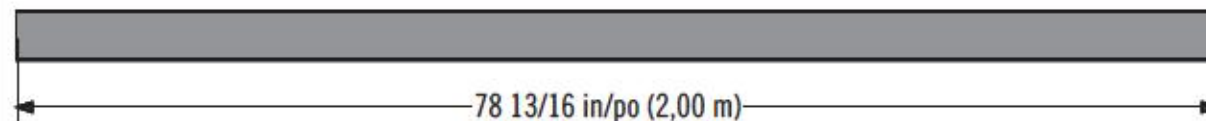

AQX (x4)

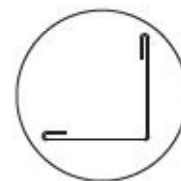

TOOLS REQUIRED / INSTRUMENTAL REQUERIDO / OUTILS REQUIS



► SECTION 13 (CONTINUED) / SECTION 13 (SUITE) / SECCIÓN 13 (CONTINUACIÓN)

TOOLS AND HARDWARE REQUIRED / OUTILS ET QUINCAILLERIE REQUIS / INSTRUMENTAL Y HERRAJE REQUERIDOS



ADX (x5)

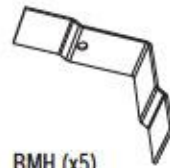

BMH (x5)

13.1

- For the 11', 18.5', and 21' sheds, attach five (5) **Metal Corner Brackets (BMH)** to the left, front corner of the shed as shown.
- Pour les tailles d'abris de 3,4 m, 5,6 m, et 6,4 m, attacher bien cinq (5) **supports angulaires en métal (BMH)** à l'encoignure avant droite de l'abri comme illustré.
- Para los tamaños de casetas de 3,4 m, 5,6 m, y 6,4 m, sujetar cinco (5) **soportes angulares de metal (BMH)** a la esquina delantera izquierda como se muestra.

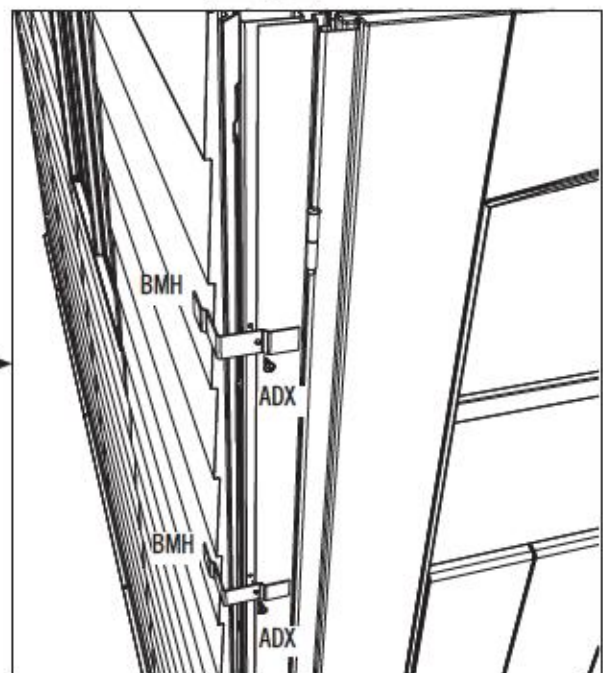
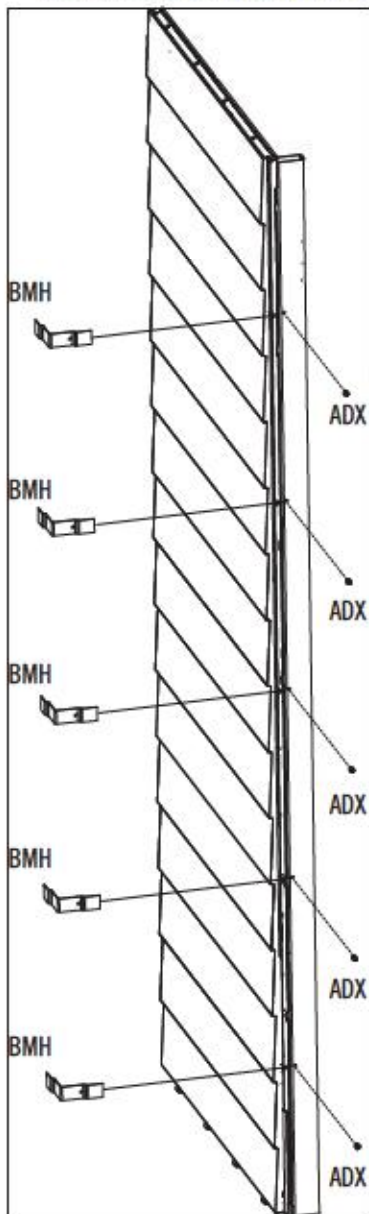

► SECTION 13 (CONTINUED) / SECTION 13 (SUITE) / SECCIÓN 13 (CONTINUACIÓN)

TOOLS AND HARDWARE REQUIRED / OUTILS ET QUINCAILLERIE REQUIS / INSTRUMENTAL Y HERRAJE REQUERIDOS



ACK (x2)



ADX (x5)

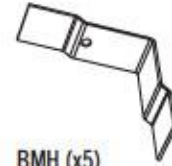

BMH (x5)

13.2

- Slide a piece of **Corner Trim (AQX)** down over the Corner Brackets as shown.
- Faire glisser une pièce de **moulure angulaire (AQX)** sur les supports angulaires comme illustré.
- Deslizar una pieza de **moldura angular (AQX)** sobre los soportes angulares como se muestra.

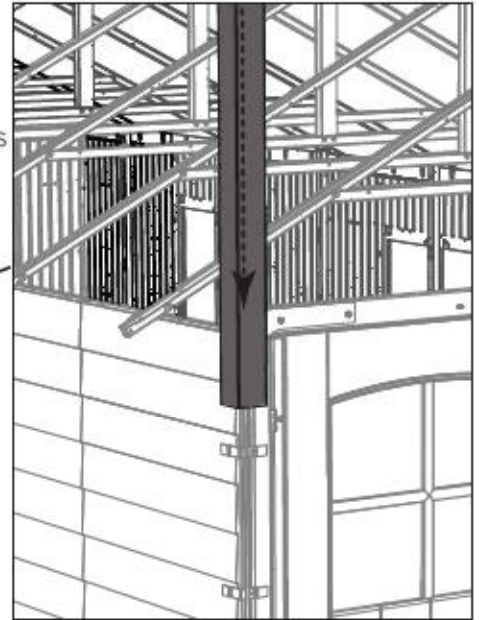

13.3

- Secure the Trim at the top with one (1) **Screw (ACK)**.
- Attacher le moulure à l'extrémité supérieure à l'aide d'une (1) **vis (ACK)**.
- Sujetar la moldura al extremo superior con un (1) **tornillo (ACK)**.

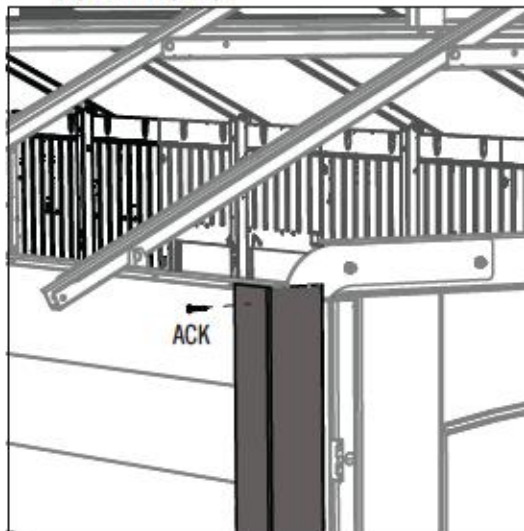

13.4

- Repeat the previous steps for the **right, front corner of the shed.**
- Répéter les étapes précédentes pour l'**encoignure avant droite de l'abri.**
- Repetira los pasos anteriores para la **esquina delantera derecha de la caseta.**

► SECTION 13 (CONTINUED) / SECTION 13 (SUITE) / SECCIÓN 13 (CONTINUACIÓN)

TOOLS AND HARDWARE REQUIRED / OUTILS ET QUINCAILLERIE REQUIS / INSTRUMENTAL Y HERRAJE REQUERIDOS



ADX (x24)



ACK (x2)

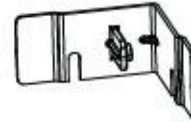

AGA (x12)

13.5

- Attach six (6) **Plastic Corner Brackets (AGA)** to the left, rear corner of the shed as shown.
- Attacher bien six (6) **supports angulaires en plastique (AGA)** à l'encoignure arrière gauche de l'abri comme illustré.
- Sujetar seis (6) **soportes angulares de plástico (AGA)** a la esquina trasera izquierda como se muestra.

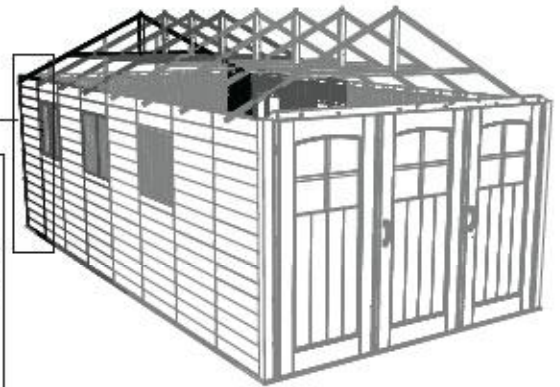
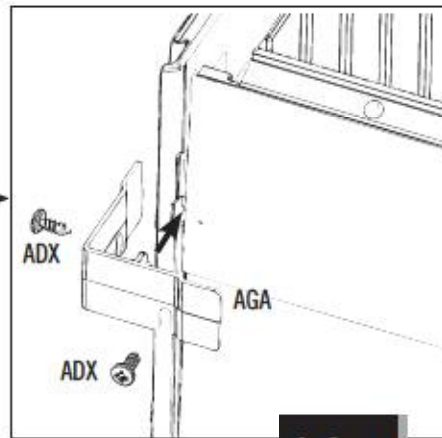
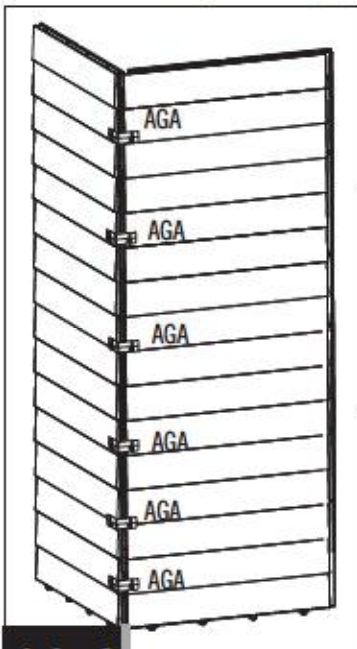

13.6

- Slide a piece of **Corner Trim (AQX)** down over the Corner Brackets. Secure the Trim at the top with one (1) **Screw (ACK)**.
- Faire glisser une pièce de **moulure angulaire (AQX)** sur les supports angulaires. Attacher le moulure à l'extrémité supérieure à l'aide d'une (1) **vis (ACK)**.
- Deslizar una pieza de **moldura angular (AQX)** sobre los soportes angulares. Sujetar la moldura al extremo superior con un (1) **tornillo (ACK)**.

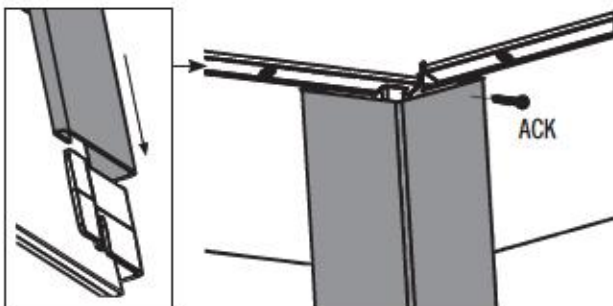

13.7

- Repeat the previous steps for the right, rear corner of the shed.
- Répéter les étapes précédentes pour l'encoignure arrière droite de l'abri.
- Repetir los pasos anteriores para la esquina trasera derecha de la caseta.

14

GABLE INSTALLATION / INSTALLATION DES PIGNONS / INSTALACIÓN DE LAS FACHADAS



HARDWARE REQUIRED / QUINCAILLERIE REQUISE / HERRAJE REQUERIDO

Hardware Bag / Sac de quincaillerie / Bolsa de herraje



ADZ (x30)



PARTS REQUIRED / PIÈCES REQUISES / PIEZAS REQUERIDAS

Metal Parts / Pièces en métal / Piezas de metal

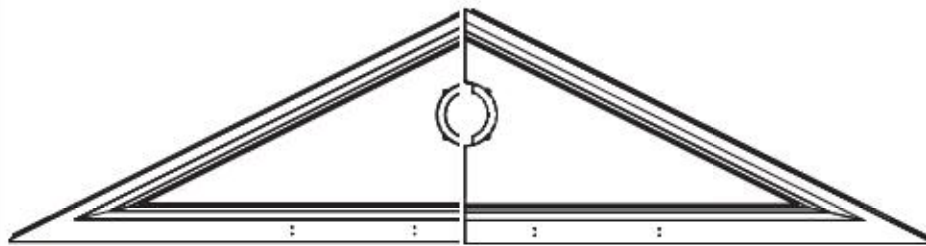

(x2)



TOOLS REQUIRED / OUTILS REQUIS / INSTRUMENTAL REQUERIDO



► SECTION 14 (CONTINUED) / SECTION 14 (SUITE) / SECCIÓN 14 (CONTINUACIÓN)

TOOLS AND HARDWARE REQUIRED / OUTILS ET QUINCAILLERIE REQUIS / INSTRUMENTAL Y HERRAJE REQUERIDOS

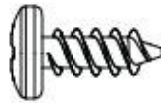

ADZ (x26)

14.1

REAR GABLE / PIGNON ARRIÈRE / FACHADA TRASERA

- Attach a Gable to the rear Wall and Wall Supports of your 11', 18.5', or 21' shed using twenty-two (22) **Screws (ADZ)** at the locations shown.
- Attacher un pignon au mur arrière et aux supports du mur de votre abri de 3,4 m, 5,6 m, ou 6,4 m à l'aide de vingt-deux (22) **vis (ADZ)** aux endroits indiqués.
- Sujetar una fachada al muro trasero y a los soportes del muro de su caseta de 3,4 m, 5,6 m, o 6,4 m usando veintidós (22) **tornillos (ADZ)** a las ubicaciones indicadas.

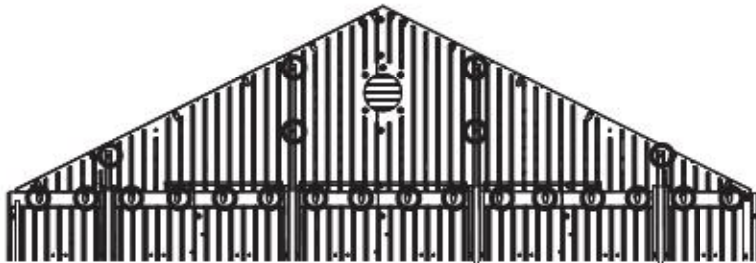

14.2

FRONT GABLE / PIGNON AVANT / FACHADA DELANTERA

- Attach a Gable to the Header of your 11', 18.5', or 21' shed at the locations indicated using four (4) **Screws (ADZ)**.
- Attacher un pignon au linteau de votre abri de 3,4 m, 5,6 m, ou 6,4 m aux endroits indiqués à l'aide de quatre (4) **vis (ADZ)**.
- Sujetar una fachada al dintel de su caseta de 3,4 m, 5,6 m, o 6,4 m a las ubicaciones indicadas usando cuatro (4) **tornillos (ADZ)**.

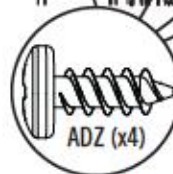
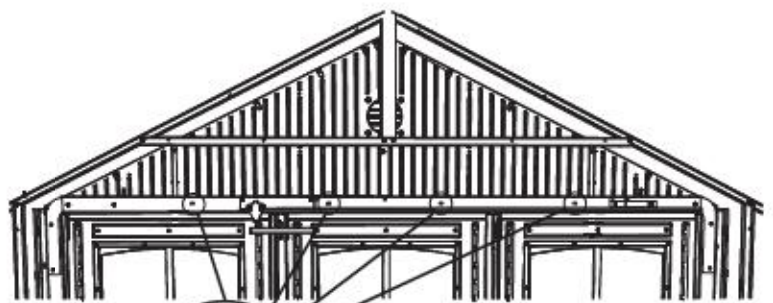
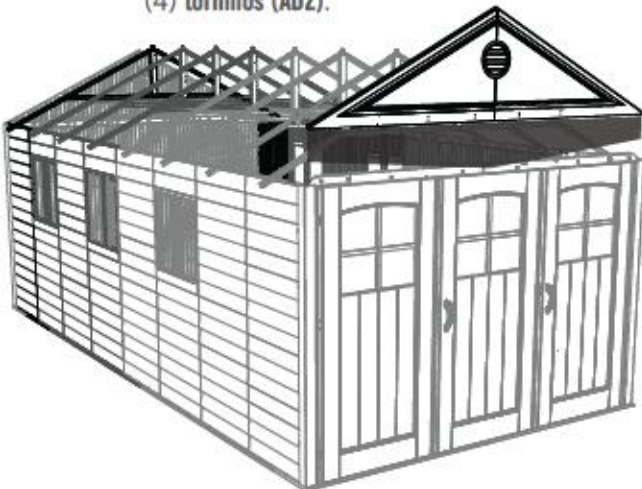



HARDWARE REQUIRED / QUINCAILLERIE REQUISE / HERRAJE REQUERIDO

Hardware Bag / Sac de quincaillerie / Bolsa de herraje

(11', 18.5', 21')



(18.5')



(21')



EVC (x18, 36, or 42)



ADZ (x232, 292, or, ou, o 372)



AJA (x20, 32, or, ou, o 36)



ADK (x1)



ADX (x4)



ACF (x1)



ACJ (x12, 24, or, ou, o 28)

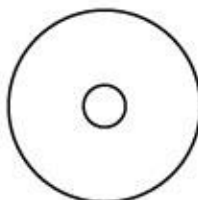

AED (x12, 24, or, ou, o 28)



• The quantities of the hardware shown below vary due to the size of your shed. Bag **EZU** is used for all three sheds. Bags **BGT** are used for both the 18.5' (5,6 m) and 21' (6,4 m) sheds.

• Les quantités de la quincaillerie illustrées à gauche varient selon le longueur de votre abri. Le sac **EZU** est utilisé pour tous les trois abris. Les sacs **BGT** sont utilisés pour les abris de 5,6 m et 6,4 m.

• Las cantidades de herraje ilustradas a la izquierda varían según el largo de su caseta. Se usa la bolsa **EZU** para todas las tres casetas. Se usan las bolsas **BGT** para la caseta de 6,4 m.



PARTS REQUIRED / PIÈCES REQUISES / PIEZAS REQUERIDAS

Metal Parts / Pièces en métal / Piezas de metal



AFL (x18, 36, or 42)

EGR

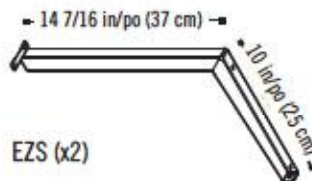

EZR (x2)

Plastic Parts / Pièces en plastique / Piezas de plástico

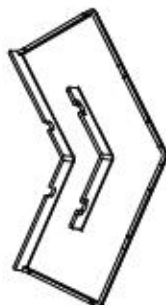

AHA (x2)

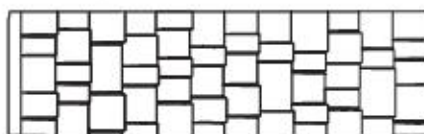

AGU (x2)

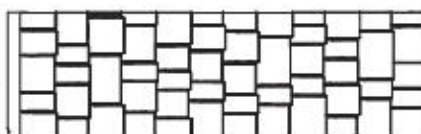

AGV (x2)

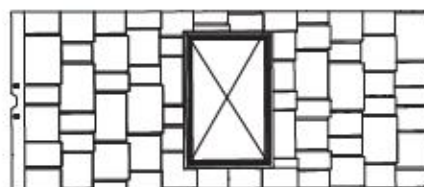

(x2)

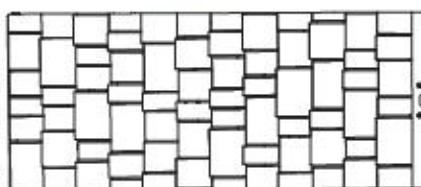

AGQ (x4, 10, or 12)



AFY (x3, 6, or 7)

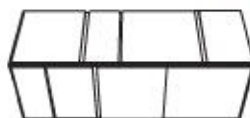

AGE (x2)



TOOLS REQUIRED / OUTILS REQUIS / INSTRUMENTAL REQUERIDO



7/16 in/po (11 mm) (x2)



3/8 in/po (10 mm)

► SECTION 15 (CONTINUED) / SECTION 15 (SUITE) / SECCIÓN 15 (CONTINUACIÓN)

TOOLS AND HARDWARE REQUIRED / OUTILS ET QUINCAILLERIE REQUIS / INSTRUMENTAL Y HERRAJE REQUERIDOS



7/16 in/po
(11 mm)



ADX (x4)



ADK (x1)



ACF (x1)

15.1

• On the Truss closest to the Doors, remove the Bolts and Nuts connecting the Horizontal Truss Brace to the Vertical Truss Brace. Now, attach the **Angle Bracket (EZS)** between the first Truss and Entry Gable as shown. Attach the Bracket to the Gable using two (2) **Screws (ADX)**, and attach the bottom of the Angle Bracket to the Header. **Repeat steps 15.1–15.2 for the Rear Gable but without the Screw and Nut for the Header. The Angle Bracket (EZS) also connects the rear-most Truss to the Rear Gable.**

• Sur la ferme la plus proche des portes, soulever les boulons et écrous qui attachent le support horizontal de la ferme aux supports verticaux de la ferme. Maintenant, attacher le **support angulaire (EZS)** à la ferme comme illustré. Ensuite, attacher le support au pignon à l'aide de deux (2) **vis (ADX)**, et attacher la partie inférieure du support au linteau. **Répéter les étapes 15.1 – 15.2 pour le pignon mais sans la vis et l'écrou pour le linteau. Le support angulaire (EZS) attache la ferme la plus arrière au pignon arrière aussi.**

• En la cercha más cercana de las puertas, retirar los pernos y tuercas que sujetan el soporte horizontal de la cercha a los soportes verticales de la cercha. Ahora, sujetar el **soporte angular (EZS)** a la cercha como se muestra. Sujetar el soporte angular a la fachada usando dos (2) **tornillos (ADX)**, y sujetar la parte inferior del soporte al dintel. **Repetir los pasos 15.1–15.2 para la fachada trasera mas sin el tornillo y la tuerca para el dintel. El soporte angular (EZS) también sujeta la última cercha a la fachada trasera.**

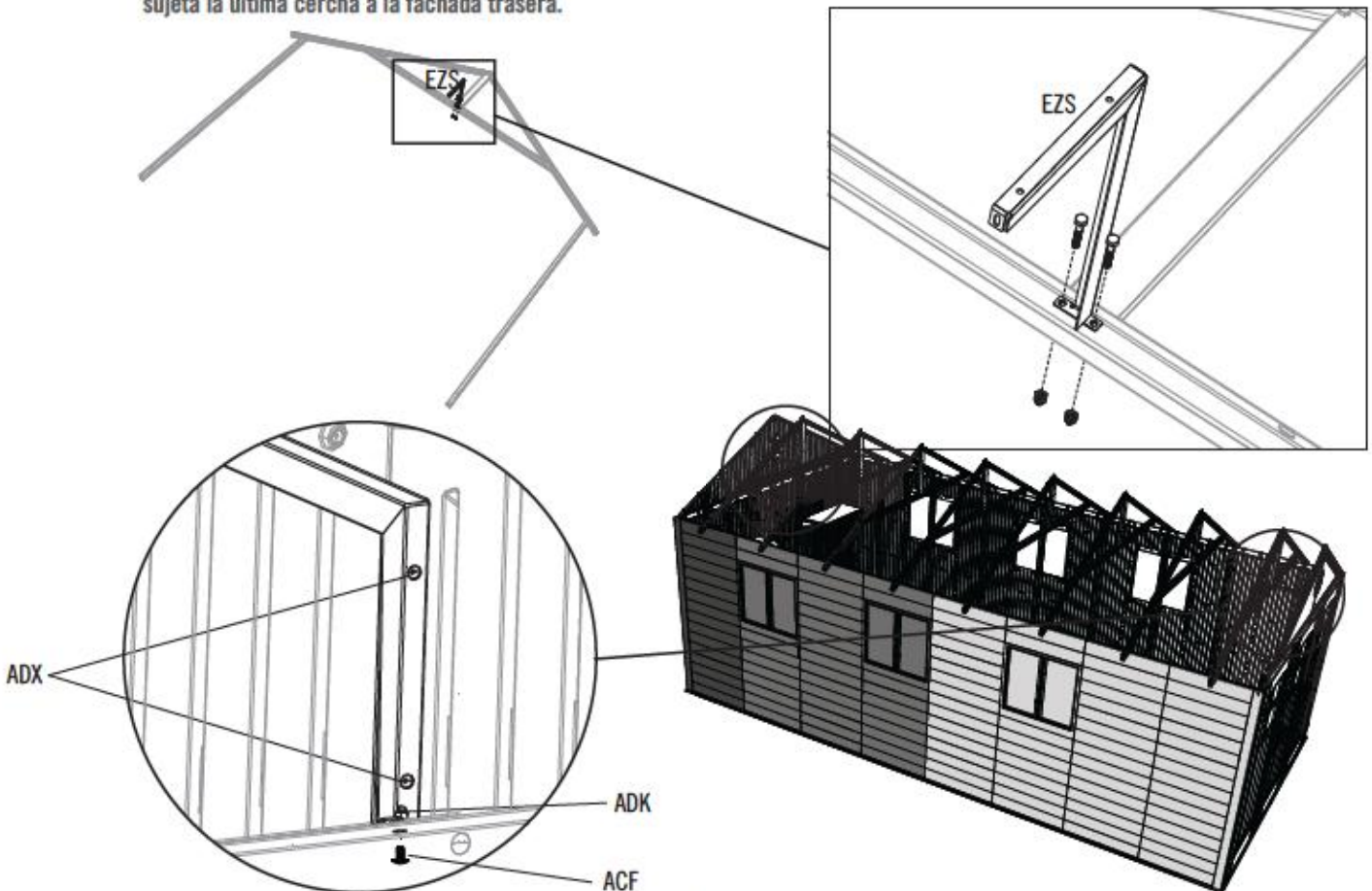

► SECTION 15 (CONTINUED) / SECTION 15 (SUITE) / SECCIÓN 15 (CONTINUACIÓN)

TOOLS AND HARDWARE REQUIRED / OUTILS ET QUINCAILLERIE REQUIS / INSTRUMENTAL Y HERRAJE REQUERIDOS

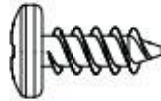

ADZ (x12)

15.2

• Set a **Roof Panel (AGU)** down onto the Truss and front Gable. Align the holes in the Truss, Gable, and Wall Panel with those in the Roof Panel. Secure the Panel using twelve (12) **Screws (ADZ)**.

• Mettre un **panneau de toit (AGU)** sur la ferme et le pignon avant. Aligner les trous dans la ferme, le pignon, et le panneau mural avec ceux dans le panneau de toit. Attacher le panneau à l'aide de douze (12) **vis (ADZ)**.

• Colocar un **panel de tejado (AGU)** sobre la cercha y la fachada delantera. Alinear los agujeros en la cercha, la fachada, y el panel mural con ellos en el panel. Sujetar el panel de tejado usando doce (12) **tornillos (ADZ)**.

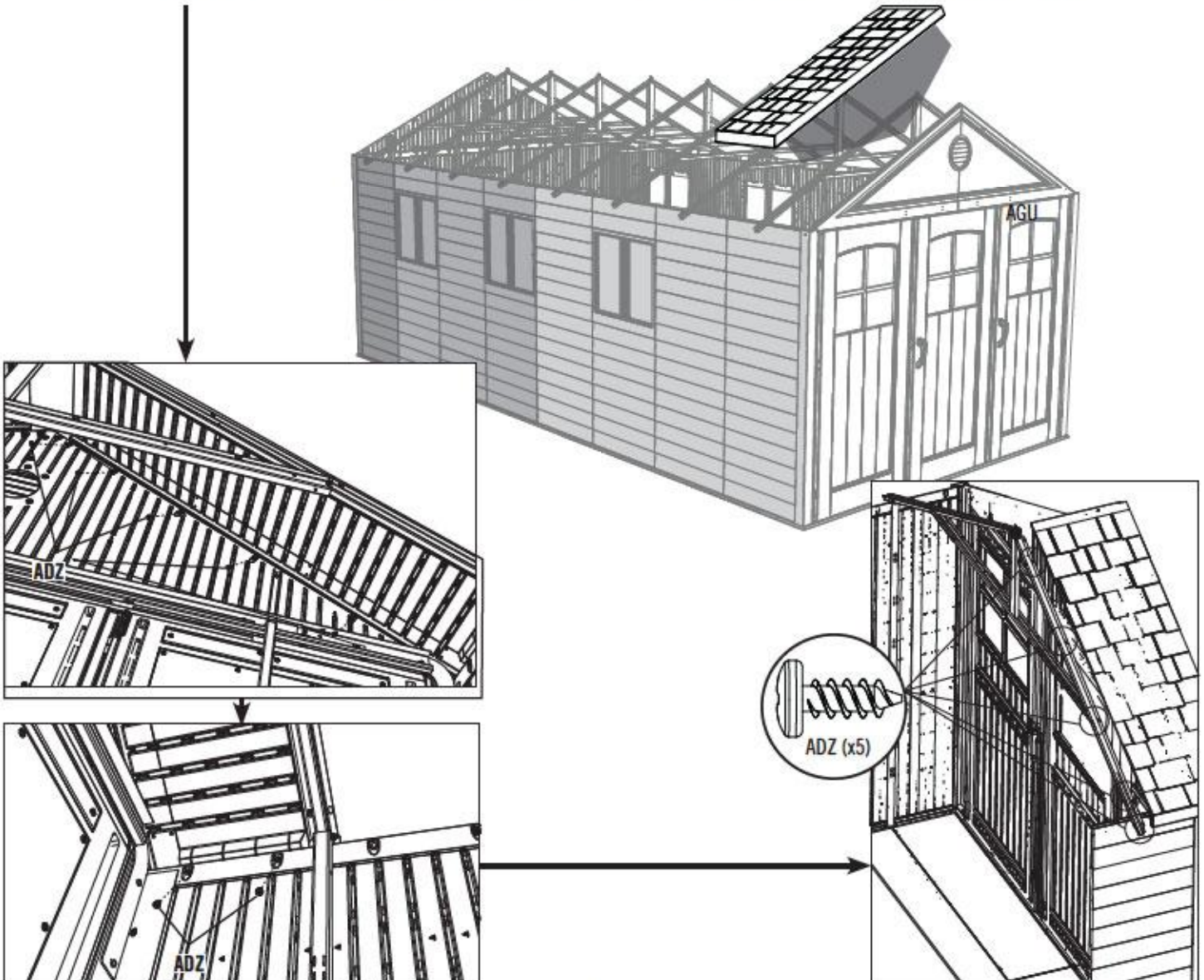

► SECTION 15 (CONTINUED) / SECTION 15 (SUITE) / SECCIÓN 15 (CONTINUACIÓN)

TOOLS AND HARDWARE REQUIRED / OUTILS ET QUINCAILLERIE REQUIS / INSTRUMENTAL Y HERRAJE REQUERIDOS

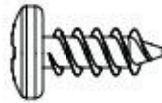

ADZ (x36)

15.3

- Repeat the previous step for Roof Panel (AGV).
- Répéter l'étape précédente pour un panneau de toit (AGV).
- Repetir el paso anterior para el panel de tejado (AGV).

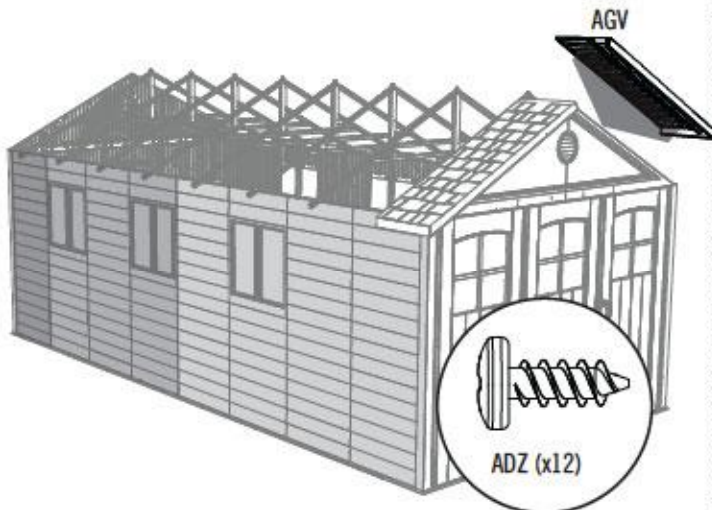

15.4

- Insert three (3) Roof Supports (AFL) into the notches on each side of the Roof Panel (AGQ or AHB) as you insert the Screws through the Truss and into the Panel. **The Roof Panels with Skylights may be placed in any Inner Roof Panel position.**
- Insérer trois (3) supports de toit (AFL) dans les encoches à chaque côté du panneau de toit (AGQ ou AHB) alors que vous insérez les vis à travers la ferme et dans le panneau. **Les panneaux de toit avec lucarnes s'attachent dans n'importe quel endroit des panneaux de toit intérieurs.**
- Insertar tres (3) soportes de tejado (AFL) en las muescas a cada lado del panel de tejado (AGQ o AHB) al insertar los tornillos a través de la cercha y en el panel. **Se sujetan los paneles de tejado con tragaluz en cualquier ubicación para los paneles de tejado interiores.**

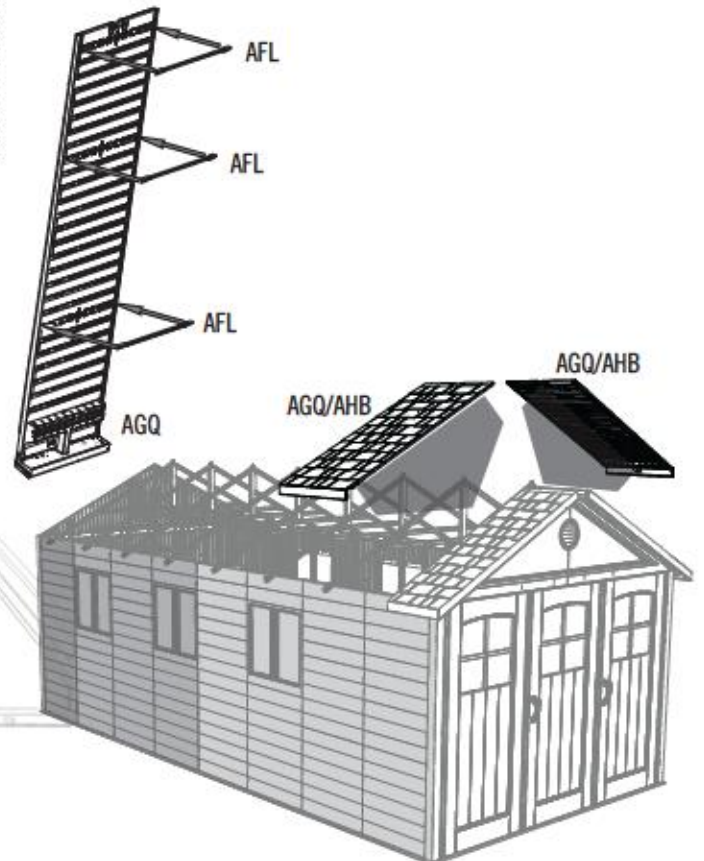

► SECTION 15 (CONTINUED) / SECTION 15 (SUITE) / SECCIÓN 15 (CONTINUACIÓN)

TOOLS AND HARDWARE REQUIRED / OUTILS ET QUINCAILLERIE REQUIS / INSTRUMENTAL Y HERRAJE REQUERIDOS



ADZ (x12)



EVC (x6)

15.5

- Secure the Roof Supports to the Roof Panels using one (1) **Support Bracket (EVC)** and two (2) **Screws (ADZ)** for each Roof Support. **The Roof Panels with Skylights may be placed in any Inner Roof Panel position.**
- Attacher bien les supports de toit aux panneaux de toit en utilisant un (1) **support (EVC)** et deux (2) **vis (ADZ)** par chaque support de toit. **Les panneaux de toit avec lucarnes s'attachent dans n'importe quel endroit des panneaux de toit intérieurs.**
- Sujetar bien los soportes de tejado a los paneles de tejado usando un (1) **soporte (EVC)** y dos (2) **tornillos (ADZ)** por soporte de tejado. **Se sujetan los paneles de tejado con tragaluz en cualquier ubicación para los paneles de tejado interiores.**

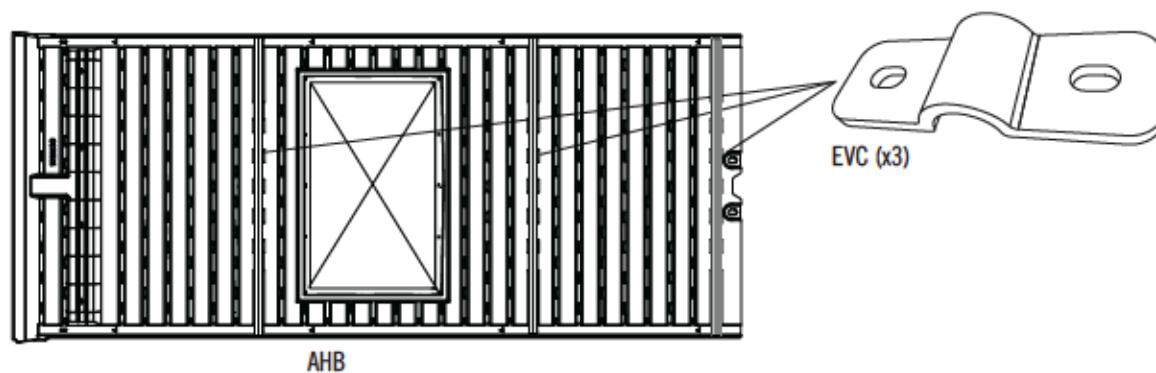
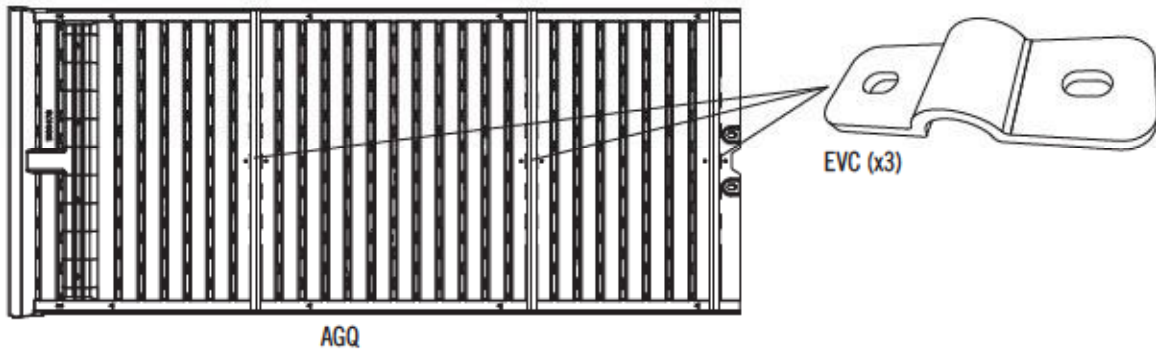

► SECTION 15 (CONTINUED) / SECTION 15 (SUITE) / SECCIÓN 15 (CONTINUACIÓN)

TOOLS AND HARDWARE REQUIRED / OUTILS ET QUINCAILLERIE REQUIS / INSTRUMENTAL Y HERRAJE REQUERIDOS

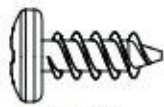

ADZ (x108)



EVC (x18)

15.6

• Secure the Roof Panels for Domed Skylights as you did the regular Roof Panels. **The Roof Panels with Skylights may be placed in any Inner Roof Panel position.**

• Attacher les panneaux de toit pour les lucarnes en forme de dôme de la même façon que les panneaux de toit normaux.

Les panneaux de toit avec lucarnes s'attachent dans n'importe quel endroit des panneaux de toit intérieurs.

• Sujetar los paneles de tejado para el tragaluz en forma de cúpula de la misma manera que los paneles de tejado normales. **Se sujetan los paneles de tejado con tragaluz en cualquier ubicación para los paneles de tejado interiores.**

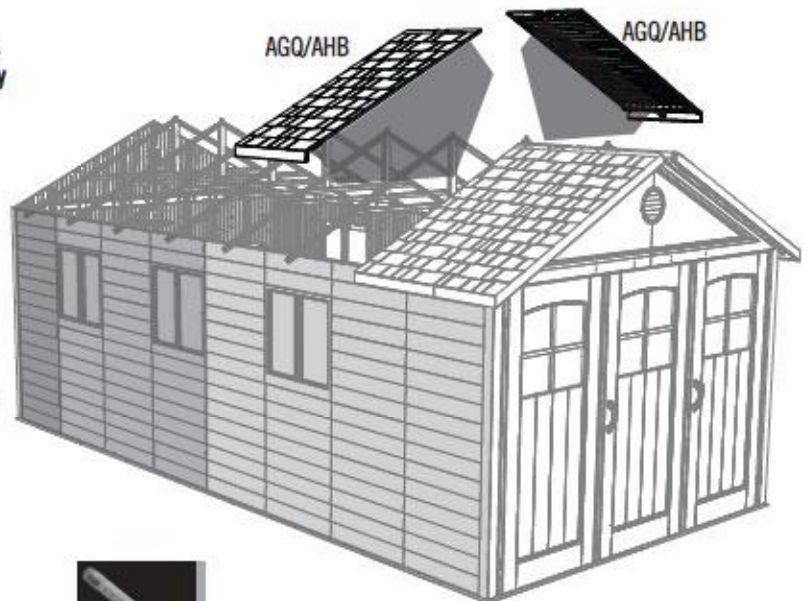

15.7

• Continue attaching the Roof Panels and Roof Supports.

• Continuer d'attacher les panneaux et supports de toit.

• Seguir sujetando los paneles y soportes de tejado.



• **If you have an 11' x 11' shed, go to step 15.9 now.** For the 18.5' and 21' sheds continue attaching **Roof Panels (AGQ or AHB).**

• **Pour l'abri de 3,35 m x 3,35 m, continuer à l'étape 15.9 maintenant.** Para los abris de 5,6 m et 6,4 m, continuer d'attacher les **panneaux de toit (AGQ or AHB).**

• **Para la caseta de 3,35 m x 3,35 m, seguir al paso 15.9 ahora.** Para las casetas de 5,6 m y 6,4 m, seguir sujetando los **paneles de tejado (AGQ or AHB).**

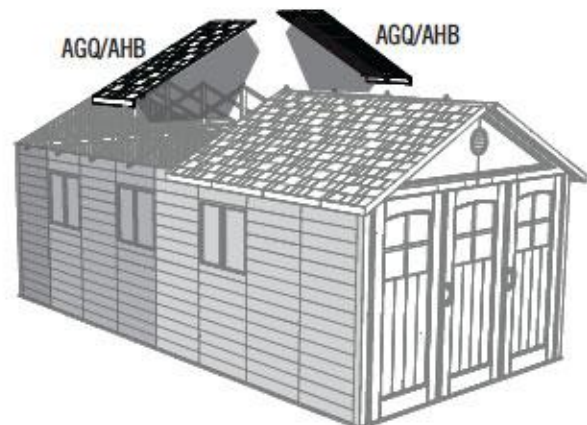
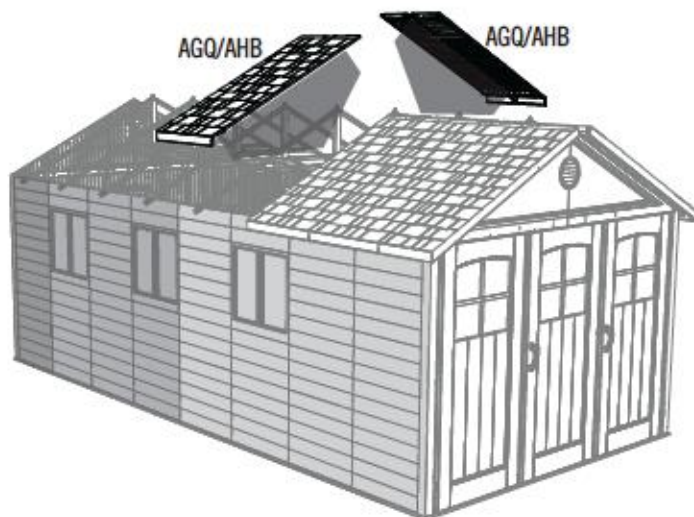

► SECTION 15 (CONTINUED) / SECTION 15 (SUITE) / SECCIÓN 15 (CONTINUACIÓN)

TOOLS AND HARDWARE REQUIRED / OUTILS ET QUINCAILLERIE REQUIS / INSTRUMENTAL Y HERRAJE REQUERIDOS



ADZ (x60 or 108)



EVC (x12 or 18)

15.8

- For the 18.5' and 21' sheds continue attaching **Roof Panels (AGQ or AHB)**.
- Para les abris de 5,6 m et 6,4 m, continuer d'attacher les **panneaux de toit (AGQ or AHB)**.
- Para las casetas de 5,6 m y 6,4 m, seguir sujetando los **paneles de tejado (AGQ or AHB)**.



18.5' and 21' / 5,6 m et 6,4 m / 5,6 m y 6,4 m



18.5' and 21' / 5,6 m et 6,4 m / 5,6 m y 6,4 m



21' (6,4 m)

► SECTION 15 (CONTINUED) / SECTION 15 (SUITE) / SECCIÓN 15 (CONTINUACIÓN)

TOOLS AND HARDWARE REQUIRED / OUTILS ET QUINCAILLERIE REQUIS / INSTRUMENTAL Y HERRAJE REQUERIDOS



ADZ (x24)

15.9

- Finally, attach the last two **Outer Roof Panels (AGU & AGV)** as you did the first two.
- Enfin, attacher les deux derniers **panneaux de toit extérieurs (AGU et AGV)** comme les premiers deux.
- Por último, sujetar los dos últimos **paneles de tejado exteriores (AGU y AGV)** como los primeros dos.



► SECTION 15 (CONTINUED) / SECTION 15 (SUITE) / SECCIÓN 15 (CONTINUACIÓN)

TOOLS AND HARDWARE REQUIRED / OUTILS ET QUINCAILLERIE REQUIS / INSTRUMENTAL Y HERRAJE REQUERIDOS

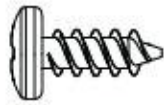

ADZ (x20, 32, or 36)

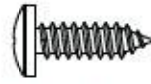

ACJ (x12, 24, or 28)

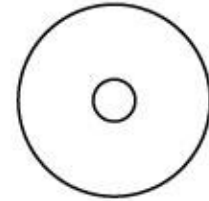

AED (x12, 24, or 28)

15.10

• Starting at the front of the shed, attach the **Roof Caps (AGE & AFY)** using the hardware included: four (4) **Screws (ADZ)** into each Truss, four (4) **Screws (ACJ)** and **Washers (AED)** for the **Center Roof Caps (AFY)** to the Roof Panels, and two (2) **Screws (ADZ)** for the **End Roof Caps (AGE)** to the Gables.

• En commençant à la partie avant de l'abri, attacher les **capuchons de toit (AGE et AFY)** à l'aide de la quincaillerie incluse : quatre (4) vis (ADZ) dans chaque ferme, quatre (4) vis (ACJ) et rondelles (AED) pour les **capuchons de toit centraux (AFY)** aux panneaux de toit, et deux (2) vis (ADZ) pour les **capuchons de toit (AGE)** aux pignons.

• Empezando a la parte delantera de la caseta, sujetar las **cumbreras de tejado (AGE y AFY)** usando el herraje incluido: cuatro (4) tornillos (ADZ) en cada armazón, cuatro (4) tornillos (ACJ) y rondanas (AED) para las **cumbreras centrales (AFY)** a los paneles de tejado, y dos (2) tornillos (ADZ) para las **cumbreras de tejado (AGE)** a las fachadas.

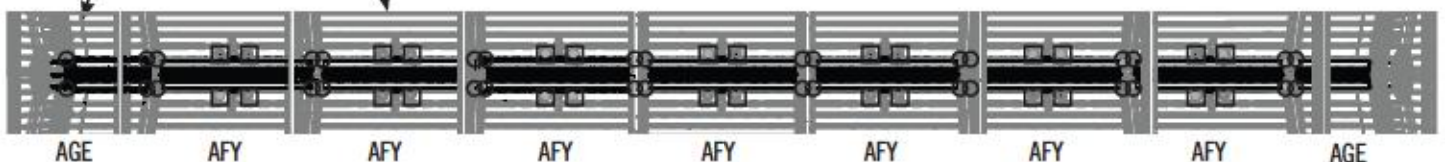
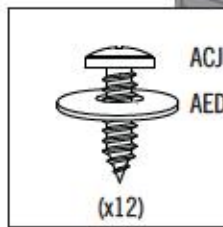
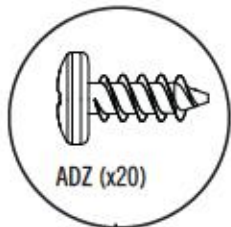
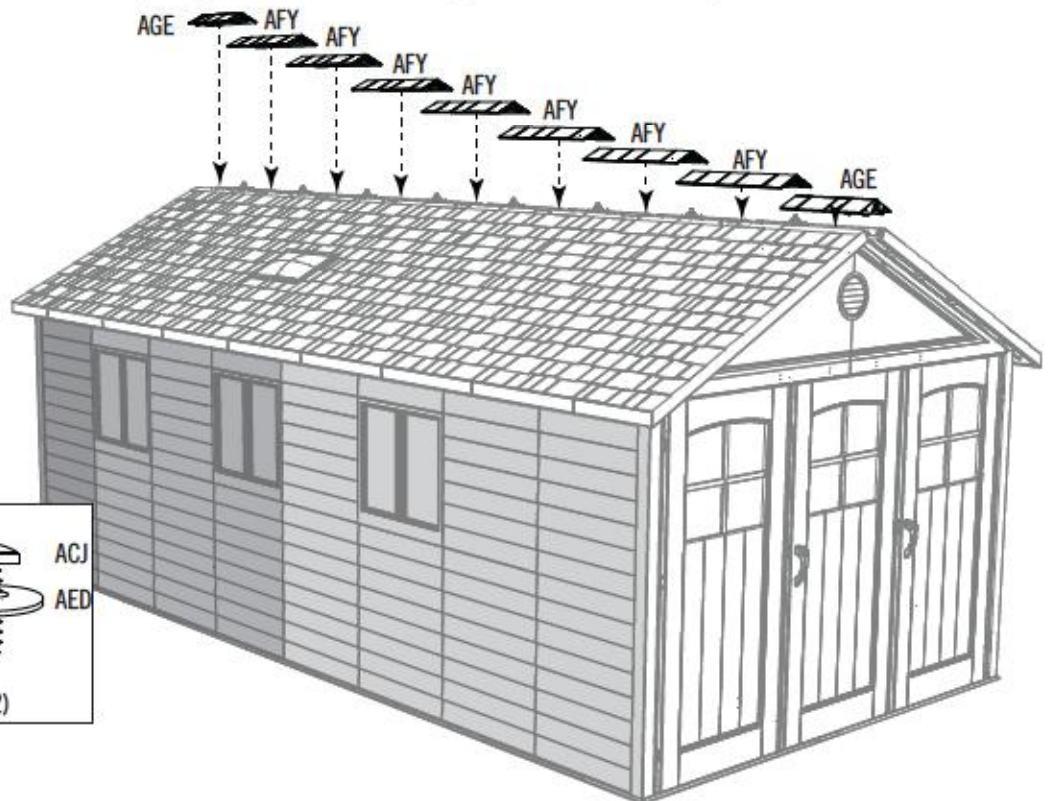

► SECTION 15 (CONTINUED) / SECTION 15 (SUITE) / SECCIÓN 15 (CONTINUACIÓN)

TOOLS AND HARDWARE REQUIRED / OUTILS ET QUINCAILLERIE REQUIS / INSTRUMENTAL Y HERRAJE REQUERIDOS

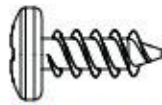

ADZ (x20, 32, or 36)



AJA (x20, 32, or 36)

15.11

- Attach the two (2) **Roof End Caps (AHA)** to the front and rear of the shed using two (2) **Screws (ADZ)** each.
- Attacher les deux (2) **façades de toit (AHA)** aux parties avant et arrière de l'abri à l'aide de deux (2) **vis (ADZ)** chaque un.
- Sujetar las dos (2) **fachadas de tejado (AHA)** a las partes delantera y trasera de la caseta usando dos (2) **tornillos (ADZ)** cada uno.

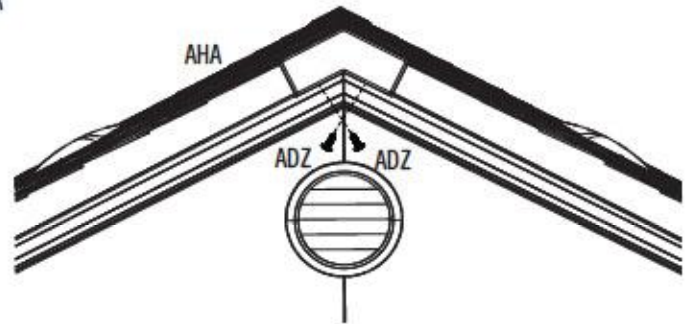
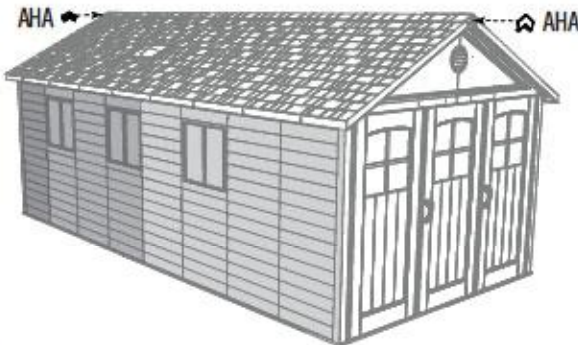

15.12

- Insert two (2) **Screws (ADZ)** through the Truss and into the Roof Panels. Insert a **Foam Block (AJA)** into the spaces between the Trusses and the top of the Wall Panels.
- Insérer deux (2) **vis (ADZ)** à travers la ferme et dedans les panneaux de toit. Insérer un **cube en mousse (AJA)** dans les espaces entre les fermes et le bord supérieur des panneaux muraux.
- Insertar dos (2) **tornillos (ADZ)** a través de la cercha y dentro de los paneles de tejado. Insertar un **cubo de espuma (AJA)** en los espacios entre las cerchas y los paneles murales.

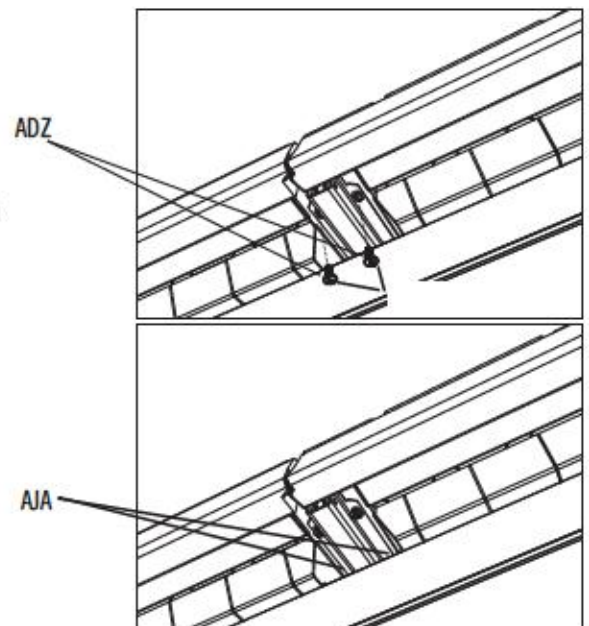
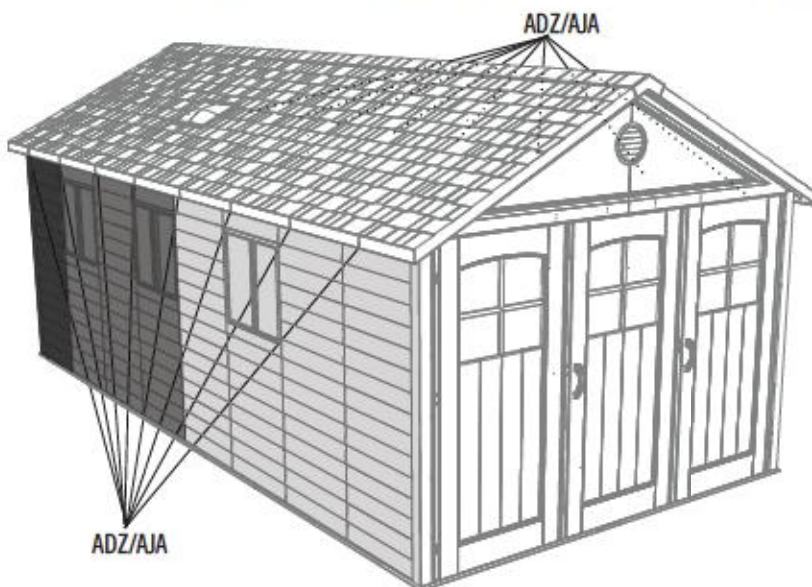



HARDWARE REQUIRED / QUINCAILLERIE REQUISE / HERRAJE REQUERIDO

Hardware Bag / Sac de quincaillerie / Bolsa de herraje

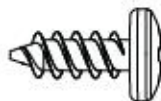

ADZ (x8, 16, or, ou, o 24)

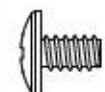

ACF (x4, 8, or, ou, o 12)



ADW (x8, 16, or, ou, o 24)

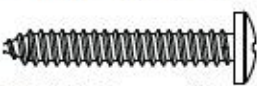

ACB (x8, 16, or, ou, o 24)



ADX (x44, 88, or, ou, o 132)

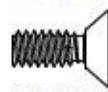

ACD (x4, 8, or, ou, o 12)



AEE (x4, 8, or, ou, o 12)



ADK (x4, 8, or, ou, o 12)



AIE (x4, 8, or, ou, o 12)



AIN (x4, 8, or, ou, o 12)



AIV (x4, 8, or, ou, o 12)



AIR (x8, 16, or, ou, o 24)



AIU (x8, 16, or, ou, o 24)

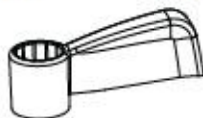

AIT (x8, 16, or, ou, o 24)

! • The quantities of the hardware shown below vary due to the size of your shed. Bags **BGU** are used for all three sheds. Bags **BNC** are used for all three sheds.
 • Les quantités de la quincaillerie illustrées à gauche varient selon le longueur de votre abri. Les sacs **BGU** sont utilisés pour tous les trois abris. Les sacs **BNC** sont utilisés pour tous les trois abris.
 • Las cantidades de herraje ilustradas a la izquierda varían según el largo de su caseta. Se usan las bolsas **BGU** para todas las tres casetas. Se usan las bolsas **BNC** para todas las tres casetas.



ADZ (x39, 78, or, ou, o 117)



PARTS REQUIRED / PIÈCES REQUISES / PIEZAS REQUERIDAS

Plastic Parts / Pièces en plastique / Piezas de plástico

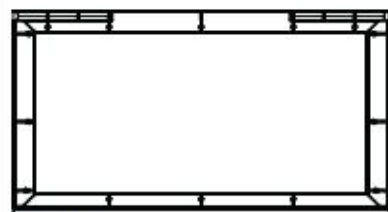

AHG (x4)

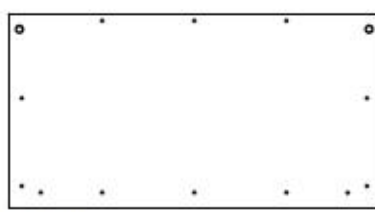

AHF (x4)

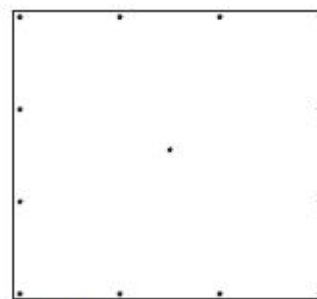

BLO (x3)



TOOLS REQUIRED / OUTILS REQUIS / INSTRUMENTAL REQUERIDO



3/8 in/po (10 mm)

► SECTION 16 (CONTINUED) / SECTION 16 (SUITE) / SECCIÓN 16 (CONTINUACIÓN)

TOOLS AND HARDWARE REQUIRED / OUTILS ET QUINCAILLERIE REQUIS / INSTRUMENTAL Y HERRAJE REQUERIDOS

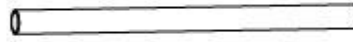

AIR (x8, 16, or 24)

16.1

- Insert each **Hinge Tube (AIR)** up into the holes at the corners of each Window as shown.
- Insérer chaque **tube de charnière (AIR)** dans les trous aux coins de chaque fenêtre comme illustré.
- Insertar cada **tubo de bisagra (AIR)** dentro de los agujeros en las esquinas de cada ventana como se muestra.

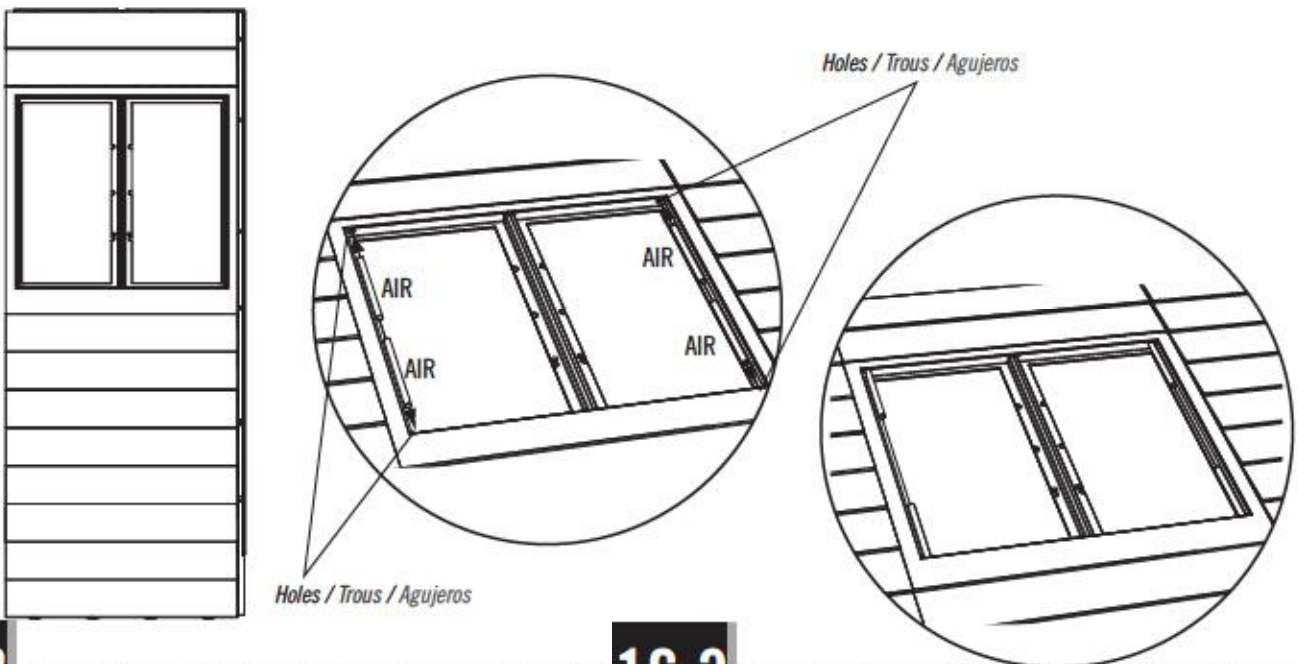

16.2

- Peel off the protective backing from both sides of the **Window Pane (AHF)**.
- Soulever la pellicule protectrice des deux côtés du **carreau (AHF)**.
- Retirar la capa protectora de las dos caras de la **hoja de ventana (AHF)**.

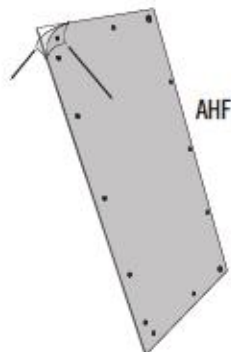

16.3

- Repeat this step for the **second Window Pane**.
- Répéter cette étape pour le **deuxième carreau**.
- Repetir este paso para la **segunda hoja de ventana**.

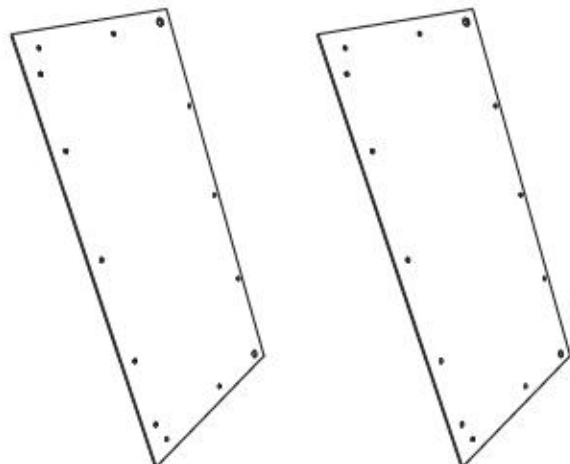

► SECTION 16 (CONTINUED) / SECTION 16 (SUITE) / SECCIÓN 16 (CONTINUACIÓN)

TOOLS AND HARDWARE REQUIRED / OUTILS ET QUINCAILLERIE REQUIS / INSTRUMENTAL Y HERRAJE REQUERIDOS



16.4

- Place a **Window Frame (AHG)** over a set of Hinge Tubes as shown.
- Mettre un **cadre de fenêtre (AHG)** sur un jeu de charnières comme illustré.
- Colocar un **marco de ventana (AHG)** sobre un juego de bisagras como se muestra.

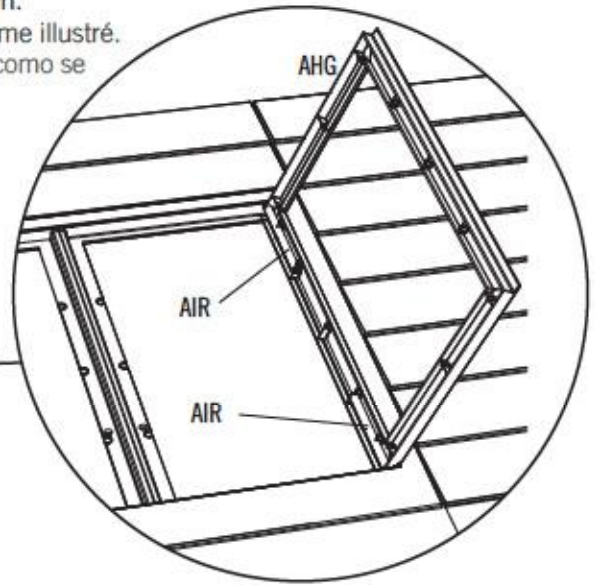
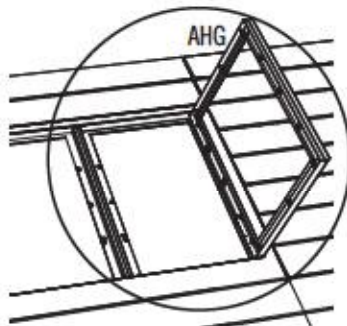
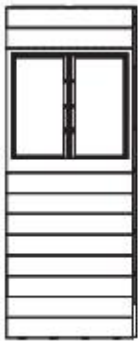

16.5

- Repeat the last step for the second Frame.
- Répéter l'étape précédente pour le deuxième fenêtre.
- Repetir el paso anterior para el segundo marco.

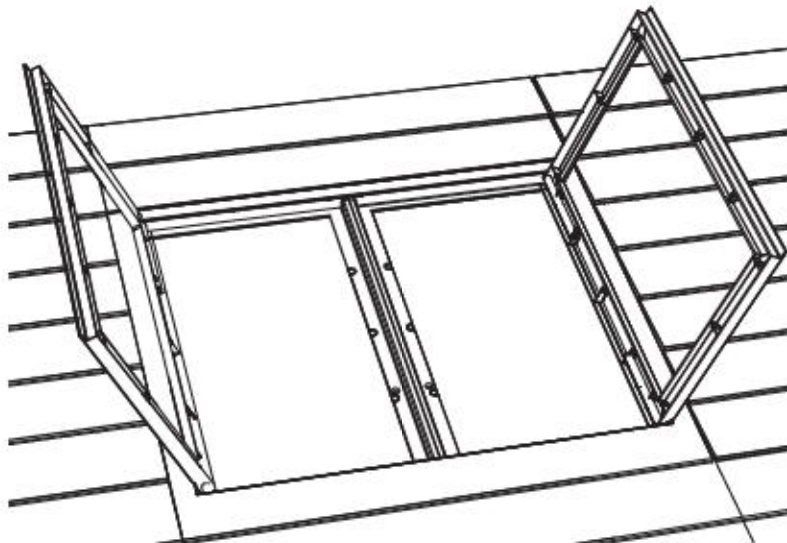

► SECTION 16 (CONTINUED) / SECTION 16 (SUITE) / SECCIÓN 16 (CONTINUACIÓN)

TOOLS AND HARDWARE REQUIRED / OUTILS ET QUINCAILLERIE REQUIS / INSTRUMENTAL Y HERRAJE REQUERIDOS



ADX (x40, 80, or 120)

16.6

- Attach the Window Panes to the Frames only at the locations indicated.
- Attacher les carreaux aux cadres seulement aux endroits indiqués.
- Sujetar las hoja de ventana a los marcos sólo a las ubicaciones indicadas.

Window Panes / Carreaux / Hojas de ventana

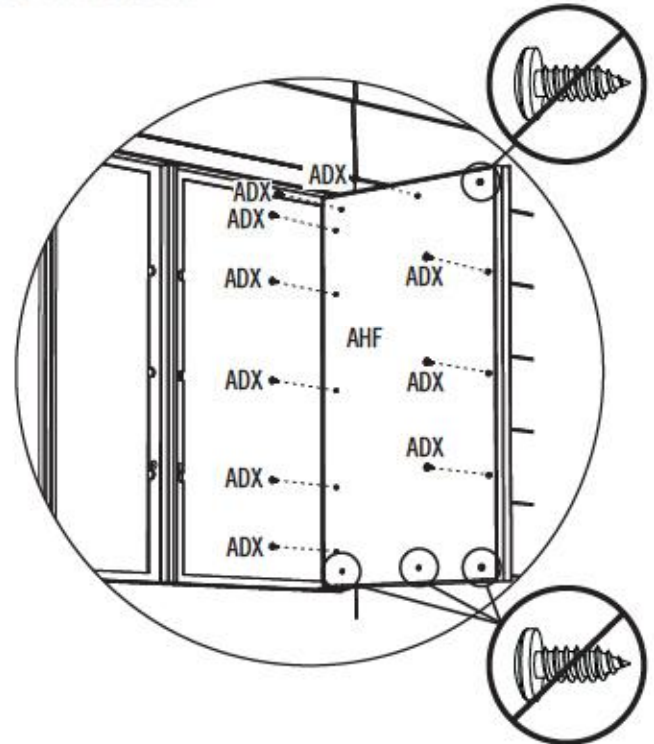
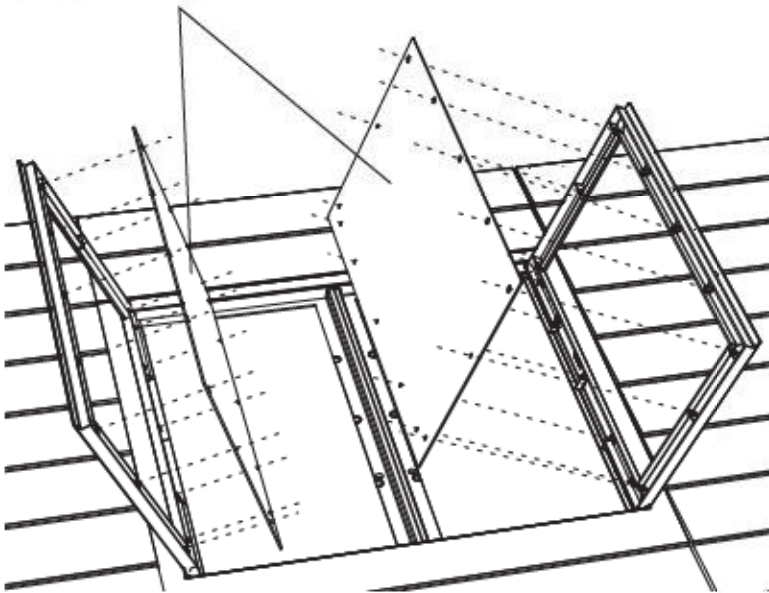

► SECTION 16 (CONTINUED) / SECTION 16 (SUITE) / SECCIÓN 16 (CONTINUACIÓN)

TOOLS AND HARDWARE REQUIRED / OUTILS ET QUINCAILLERIE REQUIS / INSTRUMENTAL Y HERRAJE REQUERIDOS

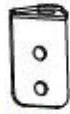

AIV (x4, 8, or, ou, o 12)

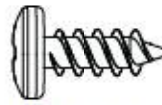

ADZ (x8, 16, or, ou, o 24)



ADW (x8, 16, or, ou, o 24)



AIE (x4, 8, or, ou, o 12)

16.7

- Attach a **Window Stay Bracket (AIV)** to each side of a Window Wall Panel as shown.
- Attacher un **support à limiteur d'ouverture de fenêtre (AIV)** à chaque côté d'un panneau mural à fenêtre comme illustré.
- Sujetar un **soporte para el limitador de apertura para la ventana (AIV)** a cada lado de un panel mural para la ventana como se muestra.

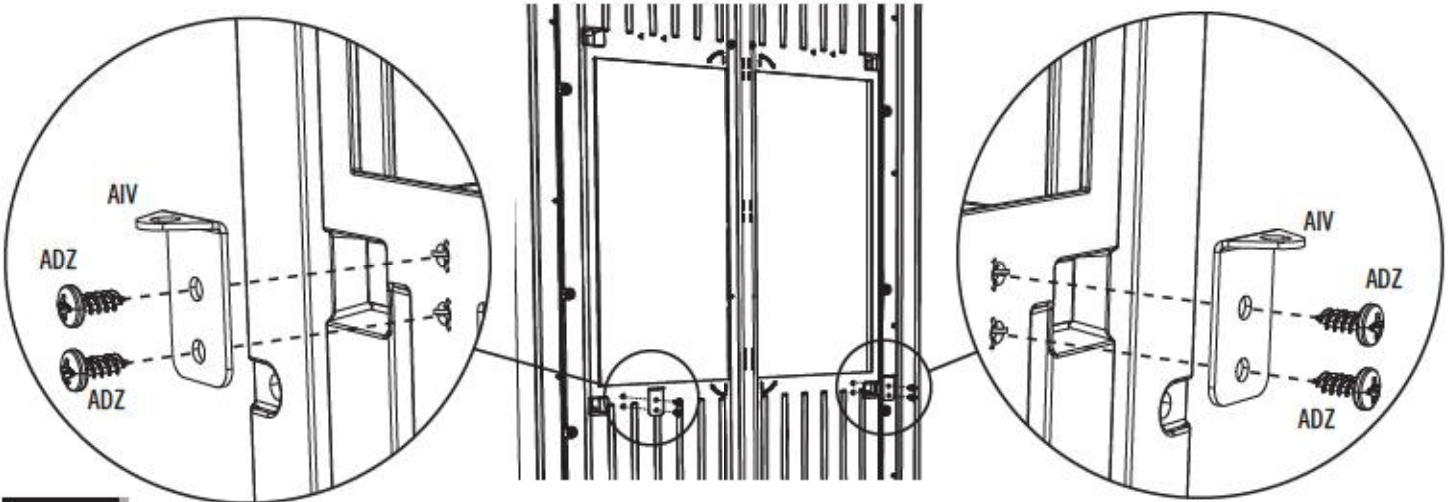

16.8

- Attach the **Window Stays (AIE)** to the Window Frames at the locations shown.
- Attacher les **limiteur d'ouverture de fenêtre (AIE)** aux cadres de fenêtre aux endroits indiqués.
- Sujetar los **limitadores de apertura para la ventana (AIE)** a los marcos de ventana a las ubicaciones indicadas.

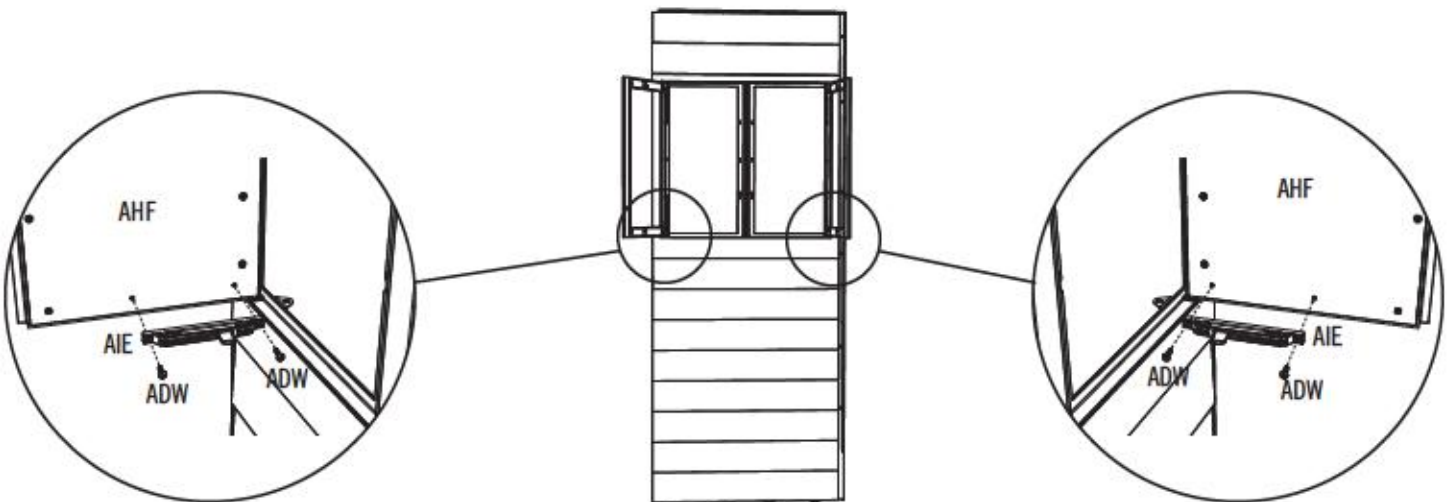

► SECTION 16 (CONTINUED) / SECTION 16 (SUITE) / SECCIÓN 16 (CONTINUACIÓN)

TOOLS AND HARDWARE REQUIRED / OUTILS ET QUINCAILLERIE REQUIS / INSTRUMENTAL Y HERRAJE REQUERIDOS



AIN (x4, 8, or, ou, o 12)



ACF (x4, 8, or, ou, o 12)



ADX (x4, 8, or, ou, o 12)



AEE (x4, 8, or, ou, o 12)

16.9

- Insert a Screw (ADX) into each Sliding Window Stay (AIN) as shown.
- Insérer une vis (ADX) dans chaque limiteur d'ouverture glissant de fenêtre (AIN) comme illustré.
- Insertar un tornillo (ADX) en cada limitador corredizo de apertura para la ventana (AIN) como se muestra.

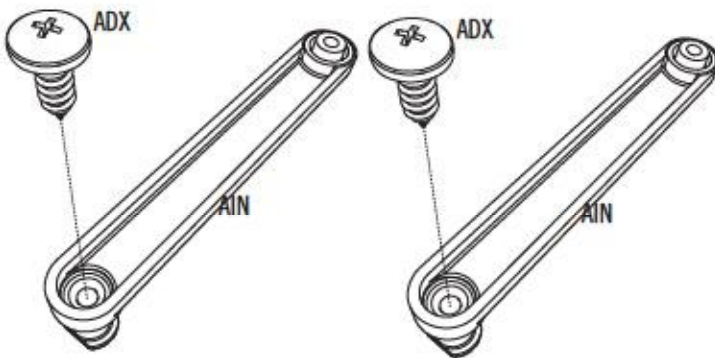

16.10

- Insert the Sliding Window Stay into Window Stay as shown. Repeat this step for a second Window Stay.
- Insérer un limiteur d'ouverture glissant de fenêtre dans un limiteur d'ouverture de fenêtre comme illustré. Répéter cette étape pour un deuxième limiteur d'ouverture de fenêtre.
- Insertar un limitador corredizo de apertura para la ventana en un limitador de apertura para la ventana como se muestra. Repetir este paso para un segundo limitador de apertura para la ventana.

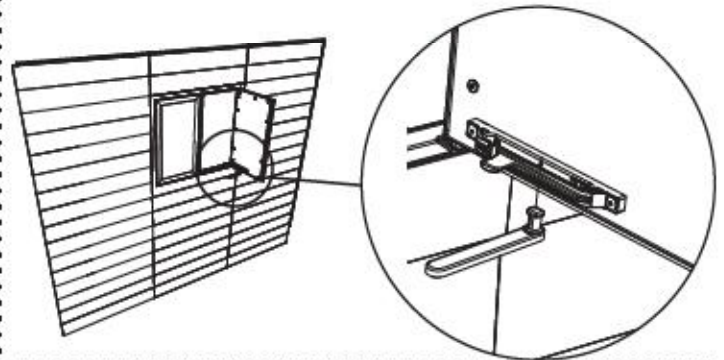

16.11

- Attach the Sliding Window Stays to the Sliding Window Stay Brackets as shown.
- Attacher le limiteur d'ouverture glissant de fenêtre au support au limiteur d'ouverture de fenêtre comme illustré.
- Sujetar el limitador corredizo de apertura para la ventana al soporte del limitador corredizo de apertura para la ventana como se muestra.

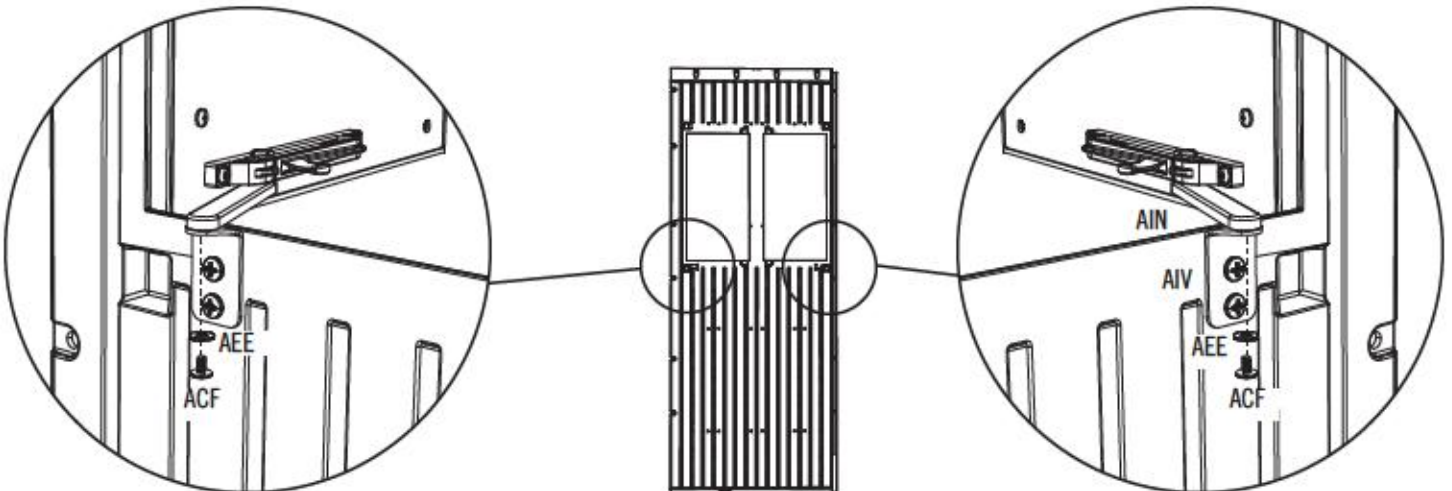

► SECTION 16 (CONTINUED) / SECTION 16 (SUITE) / SECCIÓN 16 (CONTINUACIÓN)

TOOLS AND HARDWARE REQUIRED / OUTILS ET QUINCAILLERIE REQUIS / INSTRUMENTAL Y HERRAJE REQUERIDOS



3/8 in/po
(10 mm)

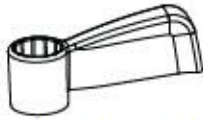

AIT (x8, 16, or, ou, o 24)



AIU (x8, 16, or, ou, o 24)

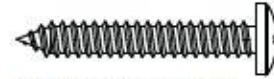

ACB (x8, 16, or, ou, o 24)



ACD (x4, 8, or, ou, o 12)



ADK (x4, 8, or, ou, o 12)

16.12

- Attach two **Window Latches (AIT)** to each Window Frame as shown.
- Attacher deux **loquets de fenêtres (AIT)** à chaque cadre de fenêtre comme illustré.
- Sujeter dos **pestillo de ventana (AIT)** a cada marco de ventana como se muestra.

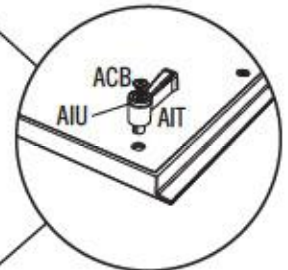
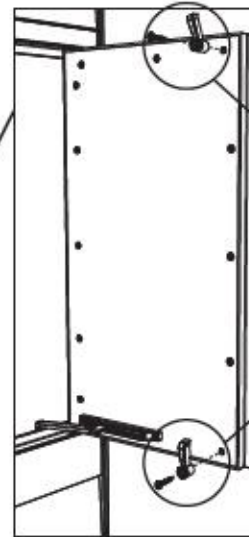
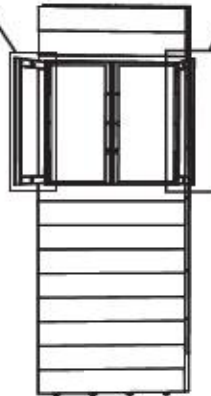
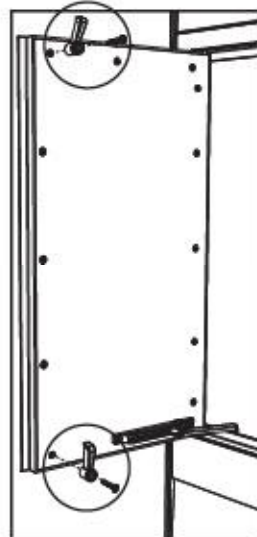
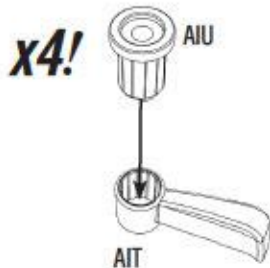

16.13

- Insert two **Screws (ACD)** through the two Window Wall Panels and Wall Support Channels. Secure each with a **Cap Nut (ADK)** as shown. **Do not overtighten the Nuts. Repeat the previous steps for all sets of Windows.**
- Insérer deux **vis (ACD)** à travers les deux panneaux muraux à fenêtre et les canaux de support muraux. Attacher chaque vis à l'aide d'un **écrou à chape (ADK)** comme illustré. **Ne pas trop serrer les écrous. Répéter les étapes précédentes pour tous les jeux de fenêtres.**
- Insertar dos **tornillos (ACD)** a través de los dos paneles murales para la ventana y los canales de soporte murales. Sujetar cada tornillo con una **tuerca ciega (ADK)** como se muestra. **No apretar demasiado las tuercas. Repetir los pasos anteriores para todos los juegos de ventanas.**

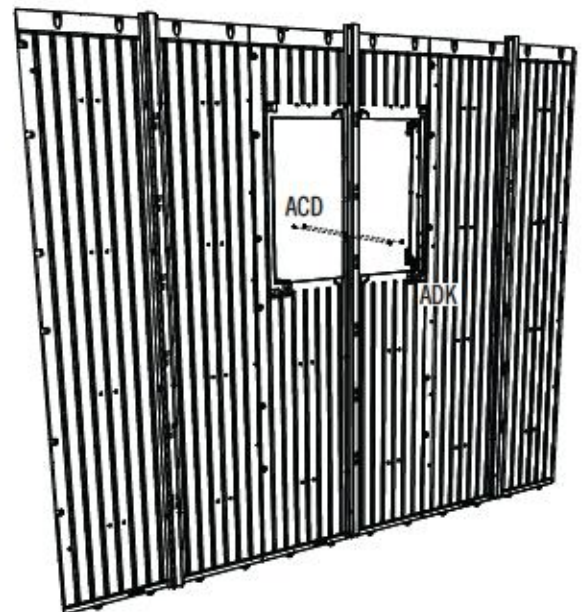

► SECTION 16 (CONTINUED) / SECTION 16 (SUITE) / SECCIÓN 16 (CONTINUACIÓN)

TOOLS AND HARDWARE REQUIRED / OUTILS ET QUINCAILLERIE REQUIS / INSTRUMENTAL Y HERRAJE REQUERIDOS

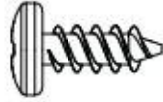

ADZ (x39, 78, or, ou, o 117)

16.14

- Peel off the protective film from both sides of a **Window Pane (BLO)**. Align the holes in the Window Pane with those in the Door, and secure with thirteen (13) **Screws (ADZ)**.
- Soulever la pellicule protectrice des deux côtés d'un **carreau (BLO)**. Aligner les trous dans le carreau avec ceux de la porte, et attacher le carreau à l'aide de treize (13) **vis (ADZ)**.
- Retire la capa protectora de las dos caras de la **hoja de ventana (BLO)**. Alinear los agujeros en la hoja con ellos en la puerta, y sujetar la hoja usando trece (13) **tornillos (ADZ)**.

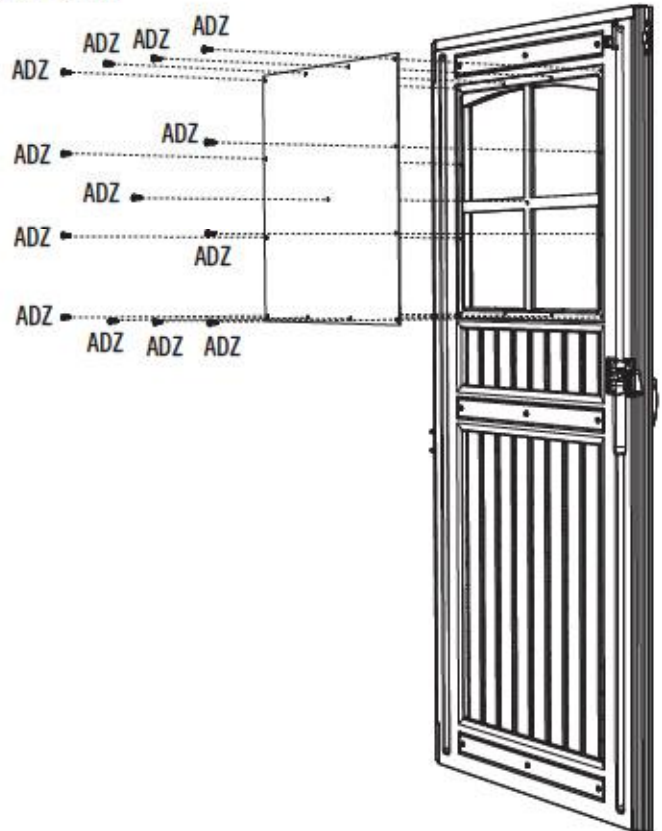
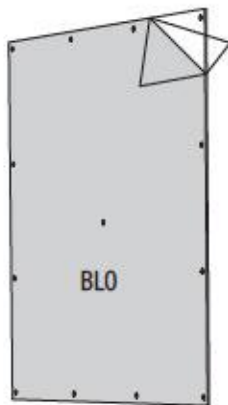

16.15

- Repeat the last step for the other two Doors.
- Répéter l'étape précédente pour les deux portes restantes.
- Repetir el paso anterior para las dos puertas restantes.



HARDWARE REQUIRED / QUINCAILLERIE REQUISE / HERRAJE REQUERIDO

Hardware Bag / Sac de quincaillerie / Bolsa de herraje



ADW (x10)

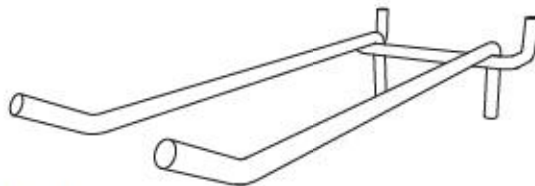

AIG (x1)



AIJ (x2)

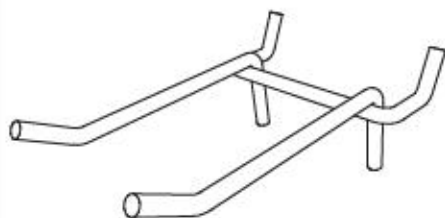

AIF (x1)



AIH (x3)

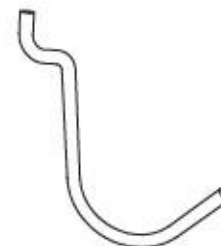

AII (x3)



PARTS REQUIRED / PIÈCES REQUISES / PIEZAS REQUERIDAS

Plastic Parts / Pièces en plastique / Piezas de plástico

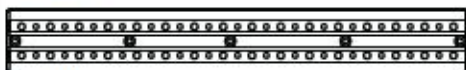

AFU (x1)



TOOLS REQUIRED / OUTILS REQUIS / INSTRUMENTAL REQUERIDO



► SECTION 17 (CONTINUED) / SECTION 17 (SUITE) / SECCIÓN 17 (CONTINUACIÓN)

TOOLS AND HARDWARE REQUIRED / OUTILS ET QUINCAILLERIE REQUIS / INSTRUMENTAL Y HERRAJE REQUERIDOS



ADW (x5)



AIG (x1)



AIF (x1)



AIH (x3)



AII (x3)



AU (x2)

17.1

• Attach the **Pegboard Strips (AFU)** to the Wall Panels using five (5) **Screws (ADW)**. Try to avoid placing the holes in the Strip over grooves in the Wall Panels. They may be attached to the side Wall Panels also.

• Attacher les **organiseurs d'outils (AFU)** aux panneaux muraux à l'aide de cinq (5) **vis (ADW)**. Essayer d'éviter situer les trous dans l'organisateur sur les rainures dans les panneaux muraux. On peut les attacher également aux panneaux muraux latéraux.

• Sujetar los **organizadores de herramientas (AFU)** a los paneles de pared usando cinco (5) **tornillos (ADW)**. Tratar de evitar de situar los agujeros en el organizador encima de las ranuras en los paneles murales. Se los pueden sujetar también a los paneles murales laterales.

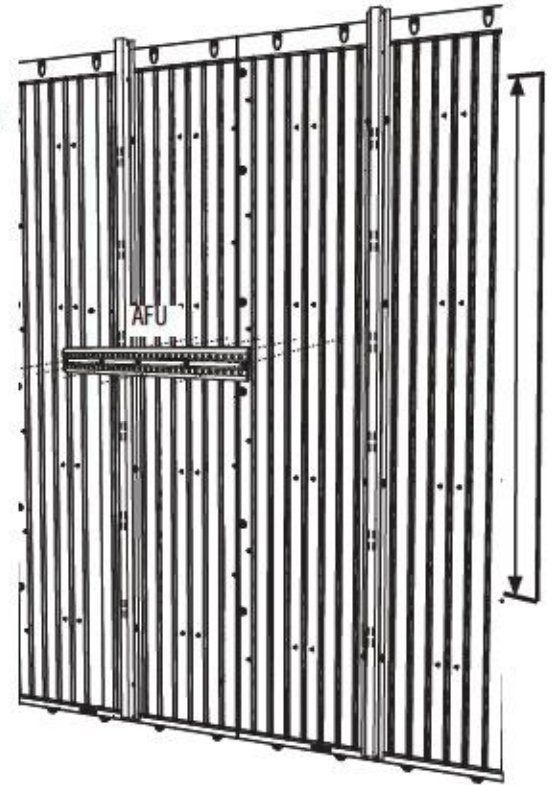

17.2

• Insert the various **Hooks (AIF, AIG, AIH, AII, AU)** as shown.

• Insérer les divers **Crochets (AIF, AIG, AIH, AII, AU)** comme illustré.

• Insertar los varios **Ganchos (AIF, AIG, AIH, AII, AU)** como se muestra.

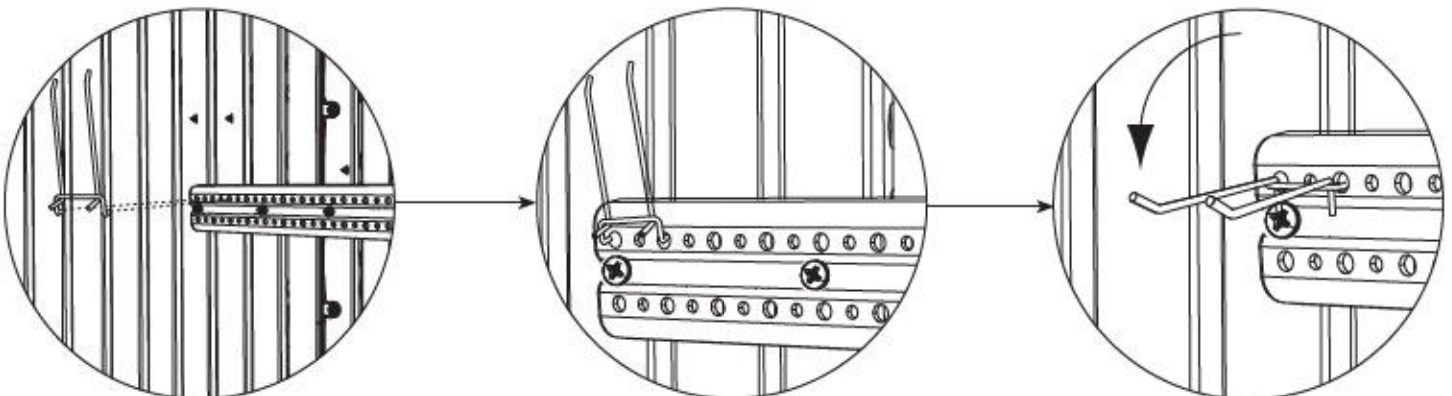

18

DOOR ALIGNMENT / ALIGNEMENT DES PORTES / ALINEACIÓN DE LAS PUERTAS



HARDWARE REQUIRED / QUINCAILLERIE REQUISE / HERRAJE REQUERIDO

Hardware Bag / Sac de quincaillerie / Bolsa de herraje



AIX (x4)



PARTS REQUIRED / PIÈCES REQUISES / PIEZAS REQUERIDAS

Parts / Pièces / Piezas



TOOLS REQUIRED / OUTILS REQUIS / INSTRUMENTAL REQUERIDO



5/16 in/po (8 mm) (x2)

► SECTION 18 (CONTINUED) / SECTION 18 (SUITE) / SECCIÓN 18 (CONTINUACIÓN)

TOOLS AND HARDWARE REQUIRED / OUTILS ET QUINCAILLERIE REQUIS / INSTRUMENTAL Y HERRAJE REQUERIDOS



- If the Doors are not even at the top, follow the steps on this page to align them.
- Si les portes ne sont pas alignées l'une avec l'autre à la partie supérieure, suivez les étapes dans cette page pour les aligner.
- Si las puertas no están alineadas a la parte superior, siga los pasos en esta página para alinearlas.



18.1

- If the Right Door scrapes the Floor or is lower than the Left Door, insert a **Shim (AIX)** under the Floor directly under the bottom corner of the Right Door. If necessary, repeat for the Left Door until the Doors are level and do not scrape. **Break off any excess Shim.**
- Si la porte droite frotte en se ferment ou est plus bas que la porte gauche, insérer une **cale (AIX)** sous le plancher directement sous le coin droit inférieur de la porte droite. Si besoin, répéter cette étape pour la porte gauche jusqu'à ce que les portes soient de niveau et ne frottent pas. **Détacher de l'excès de la cale.**
- Si la puerta derecha se roza con el piso o es más bajo que la izquierda, insertar una **cuña (AIX)** debajo el piso directamente debajo la esquina inferior derecha de la puerta derecha. Si es necesario, repetir este paso para la puerta izquierda o hasta que las puertas estén niveladas y no se rocen. **Quebrantar cualquier exceso de la cuña.**

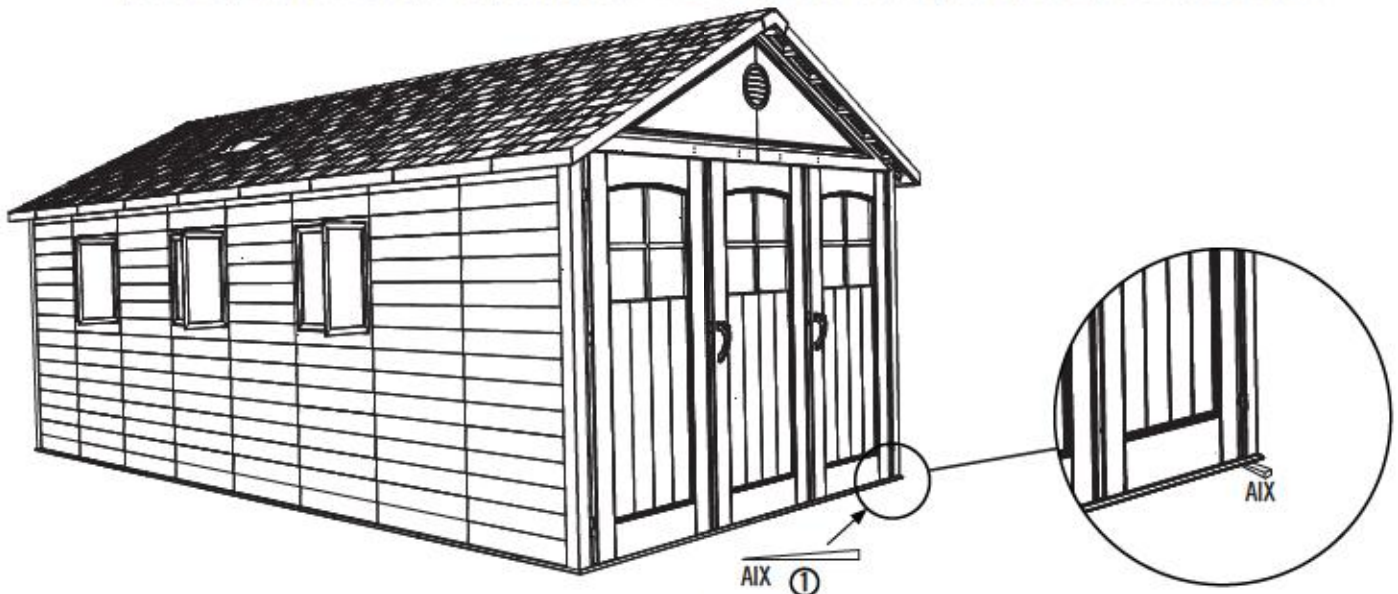

► SECTION 18 (CONTINUED) / SECTION 18 (SUITE) / SECCIÓN 18 (CONTINUACIÓN)

TOOLS AND HARDWARE REQUIRED / OUTILS ET QUINCAILLERIE REQUIS / INSTRUMENTAL Y HERRAJE REQUERIDOS



5/16 in/po (x2)
8 mm (x2)



18.2

ADJUST THE CENTER DOOR HEIGHT / REGLER LA HAUTEUR DE LA PORTE CENTRALE / AJUSTAR LA ALTURA DE LA PUERTA CENTRAL

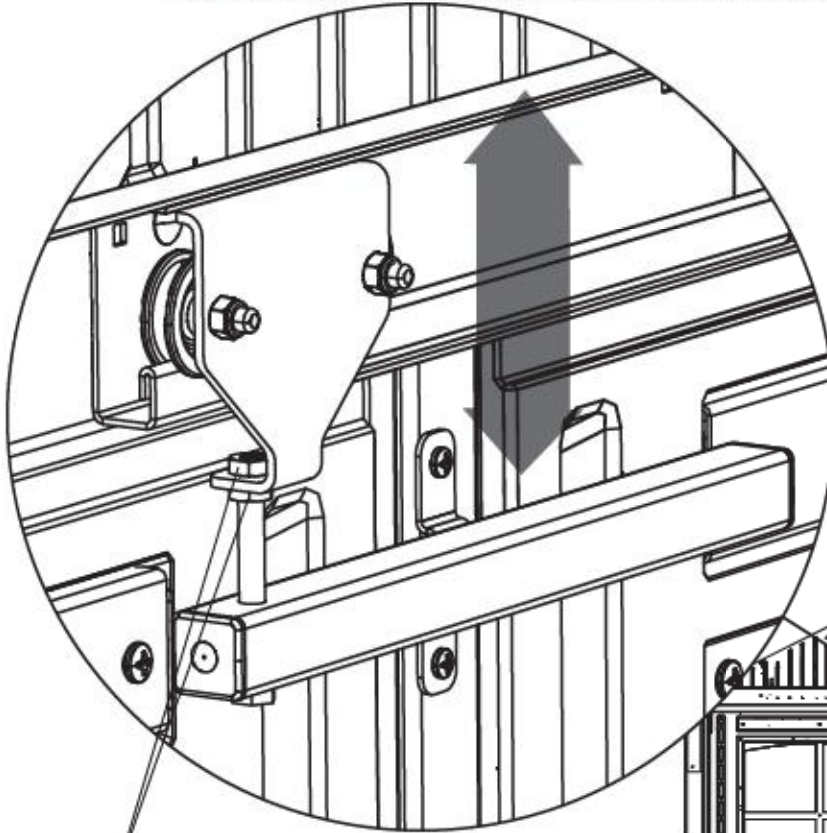
- If the Center Door rubs the Floor when closing, loosen or tighten the Nuts indicated to adjust the height.
- Si la porte centrale frotte le plancher lorsque l'on la ferme, desserrer ou serrer les écrous indiqués pour ajuster la hauteur.
- Si la puerta central fronta el piso al cerrarla, aflojar o apretar las tuercas indicadas para ajustar la altura.



Nut / Écrou / Tuerca

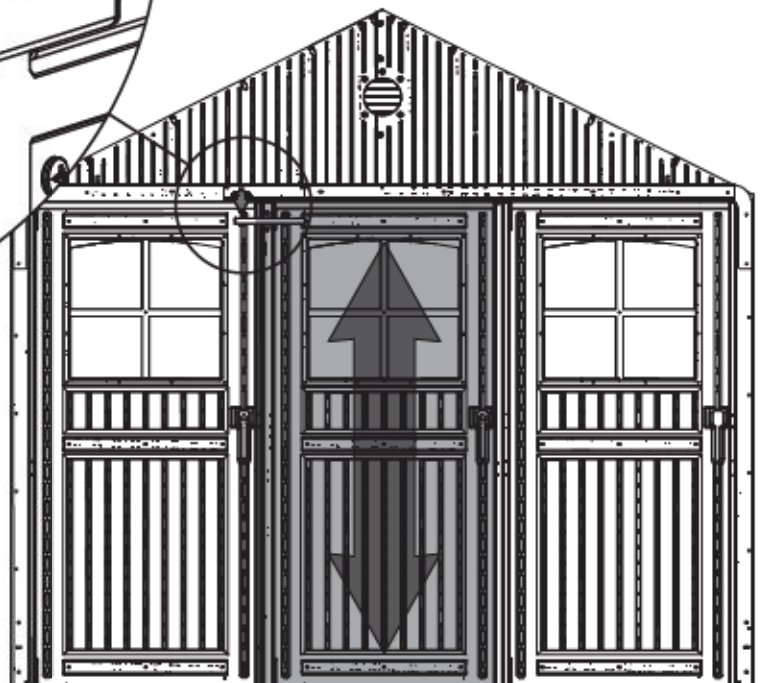

HARDWARE REQUIRED / QUINCAILLERIE REQUISE / HERRAJE REQUERIDO

Hardware Bag / Sac de quincaillerie / Bolsa de herraje

*NO HARDWARE OR PARTS INCLUDED FOR THIS SECTION
AUCUNE QUINCAILLERIE OU PIÈCE INCLUSE POUR CETTE SECTION
NINGÚN HERRAJE O PIEZA INCLUIDO PARA ESTA SECCIÓN*

PARTS REQUIRED / PIÈCES REQUISES / PIEZAS REQUERIDAS

*NO HARDWARE OR PARTS INCLUDED FOR THIS SECTION
AUCUNE QUINCAILLERIE OU PIÈCE INCLUSE POUR CETTE SECTION
NINGÚN HERRAJE O PIEZA INCLUIDO PARA ESTA SECCIÓN*

TOOLS REQUIRED / OUTILS REQUIS / INSTRUMENTAL REQUERIDO

7/16" (11 mm)



5/16" (8 mm) Wood Drill Bit
8 mm (5/16 po) Mèche à bois
8 mm (5/16 in.) Broca para madera



5/16" (8 mm) Masonry Drill Bit
8 mm (5/16 po) Mèche à maçonnerie
8 mm (5/16 in.) Broca para albañilería

► SECTION 19 (CONTINUED) / SECTION 19 (SUITE) / SECCIÓN 19 (CONTINUACIÓN)

FOR A CONCRETE PLATFORM / POUR UNE PLATE-FORME EN BÉTON / PARA UNA PLATAFORMA DE CONCRETO



19.1

- If you plan on anchoring your shed to a concrete platform, you must purchase the correct anchoring hardware. We recommend using a hammer drill, 5/16" (8 mm) masonry bit, **twelve (12), eighteen (18), or twenty (20)** 3/8" x 2" (10 mm x 5 cm) Concrete Screws and **twelve (12), eighteen (18), or twenty (20)** 3/8" x 1" (10 mm x 2,5 cm) Fender Washers at the bottom of the Trusses.
- Pour ancrer l'abri à une plate-forme en béton, il faut acheter la quincaillerie d'ancrage correcte. Nous recommandons que l'on utilise une perceuse de percussion, une mèche à maçonnerie de 8 mm (5/16 po), **douze (12), dix-huit (18), ou vingt (20)** vis d'ancrage à béton de 10 mm x 5 cm (3/8 po x 2 po) et **douze (12), dix-huit (18), ou vingt (20)** rondelles de protection de 10 mm x 2,5 cm (3/8 po x 1 po) à la partie inférieure des fermes.
- Para anclar la caseta a una plataforma hecho de concreto, es necesario comprar el herraje de anclaje correcto. Recomendamos que se usen un martillo perforador, una broca de albañilería de 8 mm (5/16 in.), **doce (12), dieciocho (18), o veinte (20)** tornillos de anclaje para concreto de 10 mm x 5 cm (3/8 in. x 2 in.) y **doce (12), dieciocho (18), o veinte (20)** rondanas de protección de 10 mm x 2,5 cm (3/8 in. x 1 in.) a la parte inferior de las cerchas.



- Do not exceed a 3/8" (10 mm) diameter screw. Refer to your local hardware store for this hardware.
- Ne pas dépasser un diamètre de 10 mm (3/8 po). La quincaillerie locale aura ces accessoires.
- No exceder un diámetro de 10 mm (3/8 in.). Refirarse a su ferretería local para obtener este herraje.

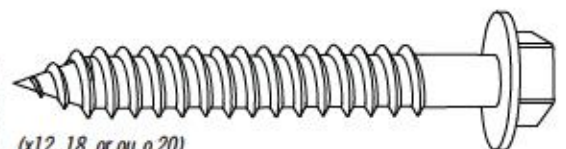
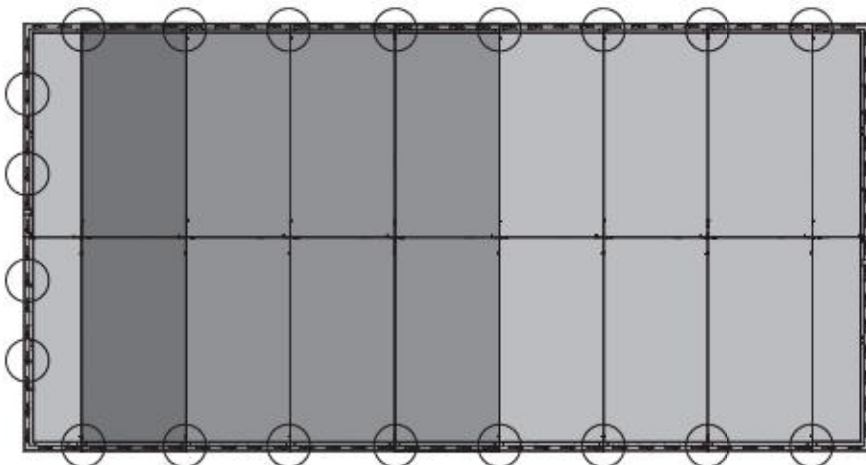

(x12, 18, or, ou, o 20)

(Not included) (Non incluses) (No incluidos)

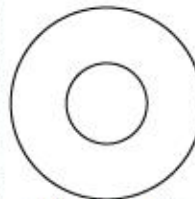

(x12, 18, or, ou, o 20)

(Not included) (Non incluses) (No incluidos)

! WARNING / AVERTISSEMENT / ADVERTENCIA !

- Failure to anchor the shed may result in property damage and/or personal injury.
- Si vous n'ancrez pas votre abri, des dommages à la propriété et/ou des blessures peuvent en résulter.
- No anclar la caseta puede resultar en daños a la propiedad y/o en lesiones personales.

▶ SECTION 19 (CONTINUED) / SECTION 19 (SUITE) / SECCIÓN 19 (CONTINUACIÓN)

FOR A CONCRETE PLATFORM / POUR UNE PLATE-FORME EN BÉTON / PARA UNA PLATAFORMA DE CONCRETO



5/16 in/po
(8 mm)



7/16 in/po
(11 mm)



19.1

- To anchor the shed to a wood platform, it's necessary to purchase the correct anchoring hardware. We recommend using a drill, 5/16" (8 mm) drill bit, **twelve (12), eighteen (18), or twenty (20)** 3/8" x 1 1/2" (10 mm x 4 cm) Lag Screws and **twelve (12), eighteen (18), or twenty (20)** 3/8" x 1" (10 mm x 2,5 cm) Fender Washers at the bottom of the Trusses.
- Pour ancrer votre abri à une plate-forme en bois, il faut acheter la quincaillerie d'ancrage correcte. Nous recommandons que l'on utilise une perceuse électrique, une mèche de 8 mm (5/16 po), **douze (12), dix-huit (18), ou vingt (20)** vis de retard de 10 mm x 4 cm (3/8 po x 1 1/2 po), et **douze (12), dix-huit (18), ou vingt (20)** rondelles de protection de 10 mm x 2,5 cm (3/8 po x 1 po) à la partie inférieure des fermes.
- Para anclar la caseta a una plataforma hecho de madera, es necesario comprar el herraje de anclaje correcto. Recomendamos que use un taladro eléctrico, una broca de 8 mm (5/16 in.), **doce (12), dieciocho (18), o veinte (20)** tornillos para madera de 10 mm x 4 cm (3/8 in. x 1 1/2 in.) y **doce (12), dieciocho (18), o veinte (20)** rondanas de protección de 10 mm x 2,5 cm (3/8 in. x 1 in.) a la parte inferior de las cerchas.



- Do not exceed a 3/8" (10 mm) diameter screw. Refer to your local hardware store for this hardware.
- Ne pas dépasser un diamètre de 10 mm (3/8 po). La quincaillerie locale aura ces accessoires.
- No exceder un diámetro de 10 mm (3/8 in.). Refirarse a su ferretería local para obtener este herraje.

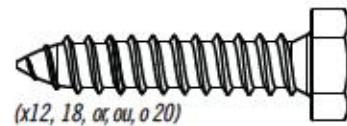
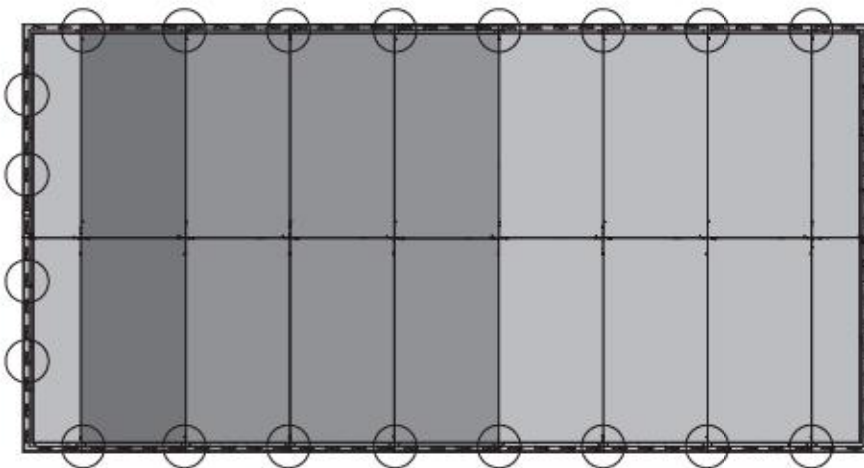

(x12, 18, or, or, or 20)

(Not included) (Non includes) (No incluidos)

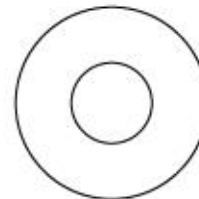

(x12, 18, or, or, or 20)

(Not included) (Non includes) (No incluidas)

⚠ WARNING / AVERTISSEMENT / ADVERTENCIA ⚠

- Failure to anchor the shed may result in property damage and/or personal injury.
- Si vous n'ancrez pas votre abri, des dommages à la propriété et/ou des blessures peuvent en résulter.
- No anclar la caseta puede resultar en daños a la propiedad y/o en lesiones personales.







CLEANING & CARE

Congratulations on your Lifetime® product purchase. By following the instructions below, your new Lifetime product should provide you with years of service and enjoyment.

The polyethylene panels are stain and solvent resistant. Most stains can be removed using a mild soap and a soft-bristled brush. Abrasive cleaning materials may scratch the plastic and are not recommended. Repair scratches or rust spots on the metal by sanding the affected area lightly; using a rust preventative spray primer; and finally, spraying with a high-gloss spray enamel paint. Avoid placing a direct heat source on or near surfaces unless using a heat barrier.



NETTOYAGE ET ENTRETIEN

Nous vous félicitons d'avoir acheté ce produit Lifetime®. En suivant les instructions ci-dessous, votre nouveau produit Lifetime devrait vous fournir des années de service et de plaisir.

Les murs et les étagères en polyéthylène sont résistants aux taches et solvants de nettoyage. Pour les nettoyer, se servir d'un savon doux et d'une brosse douce. Les produits abrasifs de nettoyage risquent d'égratigner le plastique et ne sont pas recommandés. Pour réparer les égratignures ou taches de rouille sur le métal, frotter légèrement l'endroit affecté au papier de verre, puis passer une couche de produit vaporisant préventif, et, enfin, vaporiser une peinture émail ultrabrillante. Éviter de placer une source de chaleur directe sur ou près des surfaces, ou les protéger à l'aide d'une protection contre la chaleur.



LIMPIEZA Y CUIDADO

Felicidades por la compra de su producto Lifetime®. Al seguir las siguientes instrucciones, su nuevo producto Lifetime le brindará años de servicio y satisfacción.

Los paneles de polietileno son resistentes a las manchas y solventes. La mayoría de las manchas puede removerse usando un jabón suave y un cepillo de cerdas suaves. Los materiales abrasivos para limpieza pueden rayar el plástico y no se recomiendan. Reparar rayones o manchas de óxido en el metal, lijando suavemente la parte afectada; usando un aerosol preventivo de óxido y finalmente, rociando con una pintura de esmalte brillante. Evitar poner una fuente de calor directa en o cerca de las superficies sin usar una barrera de calor.



REGISTER YOUR PRODUCT ONLINE AT WWW.LIFETIME.COM

At Lifetime®, we are committed to providing innovative and quality products. While registering, you will have the opportunity to give us your feedback. Your input is valuable to us.

- You can also opt in to receive new product notifications or promotions.
- In the unlikely event of a product recall or safety modification, your registration provides the information we need to notify you directly.
- Registration is fast, easy, and completely voluntary.

LIFETIME'S PROMISE TO YOU:

Maintaining your privacy is our long-standing policy at Lifetime®. And you can rest assured that Lifetime® will not sell or provide your personal data to other third parties, or allow them to use your personal data for their own purposes.

We invite you to read our privacy policy at www.lifetime.com

REGISTER today!



ENREGISTRER CE PRODUIT EN LIGNE À WWW.LIFETIME.COM

Chez Lifetime®, nous nous engageons à fournir des produits innovateurs de qualité. Lors de votre inscription, vous aurez l'occasion de nous faire parvenir vos commentaires. Votre opinion est importante pour nous.

- On peut également choisir de recevoir des avis ou des promotions dans le cadre de nouveaux produits.
- Dans l'éventualité improbable d'un rappel ou d'un avis de sécurité, l'inscription fournit les renseignements nécessaires nous permettant de communiquer avec vous.
- L'inscription est rapide, facile et complètement volontaire.

LA PROMESSE DE LIFETIME :

Conserver votre confidentialité est notre politique de longue date chez Lifetime®. Vous pouvez donc être rassuré par le fait que Lifetime® ne vendra pas ou ne fournira pas vos données personnelles à des tiers, et ne leur permettra pas d'utiliser vos données personnelles à leurs propres fins.

Nous vous invitons à lire notre politique de confidentialité à www.lifetime.com (en anglais seulement)

ENREGISTRER CE PRODUIT aujourd'hui!



REGISTRAR EL PRODUCTO EN LÍNEA EN WWW.LIFETIME.COM

En Lifetime®, estamos comprometidos a ofrecer productos innovadores y de calidad. Al registrarse, usted tendrá la oportunidad de darnos su retroalimentación. Su información es valiosa para nosotros.

- También puede optar por recibir nuestras notificaciones o promociones.
- En el caso improbable de que el producto tenga que salir del mercado o que sufra alguna modificación, su registro provee la información que necesitamos para notificarle directamente.
- El registro es rápido, fácil y completamente voluntario.

LA PROMESA DE LIFETIME® PARA USTED:

Mantener privacidad es nuestra política permanente en Lifetime®. Y puede estar seguro que Lifetime® no venderá ni dará datos personales a terceros, ni les permitirá usar datos personales para fines propios.

Lo invitamos a leer nuestra política de privacidad en www.lifetime.com (sólo en inglés)

¡REGISTRARSE hoy mismo!



10-YEAR LIMITED FACTORY WARRANTY

THE MANUFACTURER RESERVES THE RIGHT TO MAKE SUBSTITUTIONS TO WARRANTY CLAIMS IF PARTS ARE UNAVAILABLE OR OBSOLETE.

1. Lifetime outdoor sheds are warranted to the original purchaser to be free from defects in material or workmanship for a period of ten years from the date of original retail purchase. The word "defects" is defined as imperfections that impair the use of the product. Defects resulting from misuse, abuse or negligence will void this warranty. This warranty does not cover defects due to improper installation, alteration or accident. This warranty does not cover damage caused by vandalism, rusting, "acts of nature" or any other event beyond the control of the manufacturer.
2. This warranty is nontransferable and is expressly limited to the repair or replacement of defective product. If the product is defective within the terms of this warranty, Lifetime Products, Inc. will repair or replace defective parts at no cost to the purchaser. Shipping charges to and from the factory or distribution center are not covered and are the responsibility of the purchaser. Labor charges and related expenses for removal, installation or replacement of the shed or its components are not covered under this warranty.
3. This warranty does not cover scratching or scuffing of the product that may result from normal usage. In addition, defects resulting from intentional damage, negligence, unreasonable use or hanging from the truss will void this warranty.
4. Liability for incidental or consequential damages is excluded to the extent permitted by law. While every attempt is made to embody the highest degree of safety in all equipment, freedom from injury cannot be guaranteed. The user assumes all risk of injury resulting from the use of this product. All merchandise is sold on this condition, and no representative of the company may waive or change this policy.
5. This product is not intended for institutional or commercial use; Lifetime Products, Inc. does not assume any liability for such use. Institutional or commercial use will void the warranty.
6. Our goods come with guarantees that cannot be excluded under the Australian Consumer Law. You are entitled to a replacement or refund for a major failure and for compensation for any other reasonably foreseeable loss or damage. You are also entitled to have the goods repaired or replaced if the goods fail to be of acceptable quality and the failure does not amount to a major failure.
7. This warranty is expressly in lieu of all other warranties, expressed or implied, including warranties of merchantability or fitness for use to extent permitted by Federal and state law. Neither Lifetime Products, Inc., nor any representative assumes any other liability in connection with this product. This warranty gives you specific legal rights, and you may also have other rights which vary from state to state (or province to province, as applicable in Canada).

PLEASE INCLUDE YOUR DATED SALES RECEIPT AND PHOTOGRAPHS OF DAMAGED PARTS.

REPORT PRODUCT DEFECTS IN WRITING TO:
Lifetime Products, Inc., PO Box 160010 Clearfield, UT 84016-0010
or call 1-800-225-3865 M-F 7 a.m. to 5 p.m. MST.

REGISTER YOUR PRODUCT FOR QUICKER CUSTOMER SERVICE.

Visit www.lifetime.com or call 1-800-225-3865 to register your product today.

FOR INTERNATIONAL WARRANTY CLAIMS:

All warranty claims must be accompanied by a sales receipt. Report all warranty claims in writing to your regional sales support representative. Please include your dated sales receipt and photographs of damaged parts. To identify the representative for your region, please visit: www.lifetime.com/international



www.lifetime.com



GARANTÍA DE FÁBRICA LIMITADA POR 10 AÑOS

EL FABRICANTE SE RESERVA EL DERECHO DE HACER SUSTITUCIONES EN LOS ELEMENTOS REEMPLAZADOS BAJO GARANTÍA SI LAS PIEZAS NO ESTÁN DISPONIBLES O SON OBSOLETAS.

1. El comprador original recibe la garantía de que las casetas Lifetime estarán libres de defectos de material o de mano de obra por un período de 10 años a contar desde la fecha de la compra original. La palabra "defectos" se define como imperfecciones que perjudican el uso del producto. Los defectos emergentes de un mal uso, abuso o negligencia invalidarán esta garantía. Esta garantía no cubre defectos debidos a una instalación o alteración incorrecta o a un accidente. Esta garantía no cubre daños causados por vandalismo, oxidación, "actos de la naturaleza" u otros eventos que estén más allá del control del fabricante.
2. Esta garantía es intransferible, y queda expresamente limitada a la reparación o reemplazo de los productos defectuosos. Si el producto se encuentra defectuoso dentro de los términos de esta garantía, Lifetime Products, Inc. reparará o reemplazará las piezas defectuosas sin costo alguno para el comprador. Los gastos de envío hacia y desde la fábrica no están cubiertos, y quedan bajo la responsabilidad del comprador.
3. Esta garantía no cubre raspaduras ni marcas en el producto que pueden resultar de su uso normal. Además, los defectos causados por daños intencionales, negligencia, uso irrazonable o por colgarse de las cabriadas invalidarán esta garantía.
4. La responsabilidad por daños incidentales o consecuentes queda excluida hasta el punto en que lo permita la ley. Si bien se hace el mayor esfuerzo posible para lograr el más alto grado de seguridad en todos nuestros equipos, no puede garantizarse la libertad de cualquier tipo de lesión. El usuario asume todos los riesgos de lesiones emergentes del uso de este producto. Toda nuestra mercadería se vende bajo esta condición, y ningún representante de la compañía puede anular ni cambiar esta política.
5. Este producto no está pensado para el uso institucional ni comercial; Lifetime Products, Inc. no asume ninguna otra responsabilidad en conexión con este producto. El uso institucional o comercial invalidará la garantía.
6. Nuestros productos vienen con garantías que no se pueden excluir bajo la Ley del consumidor de Australia. Ustedes están autorizados para reemplazarlos u otorgar una devolución o reembolso en caso de falla mayor y en compensación por cualquier otra falla o daño previsible. También, están autorizados para hacer reparar los productos o reemplazarlos si éstos no cumplen con una calidad aceptable y si la falla no es motivo de una deficiencia mayor.
7. Esta garantía se otorga en reemplazo expreso de toda otra garantía, expresa o implícita, incluidas las garantías de comercialización o adaptación para el uso en la medida permitida por las leyes federales y estatales. Ni Lifetime Products, Inc., ni ninguno de sus representantes asume ninguna otra responsabilidad en conexión con este producto. Esta garantía le otorga derechos legales específicos, y usted puede tener otros derechos que varían de estado a estado (o de una provincia a otra, según corresponda en Canadá).

NINGUNA GARANTÍA OFRECIDA POR EL FABRICANTE ES VÁLIDA EN MÉXICO

TODOS LOS RECLAMOS DE GARANTÍA DEBEN ESTAR ACOMPAÑADOS POR UN RECIBO DE COMPRA

INFORME POR ESCRITO LOS DEFECTOS EN EL PRODUCTO A:

Por favor, incluir el recibo de compra fechado y fotografías de las piezas dañadas.

Lifetime Products, Inc., PO Box 160010 Clearfield, UT 84016-0010,

o marcar al 1.800.225.3865 de lunes a viernes de 0700 hasta 1700 (Hora de las Montañas)

REGISTRAR SU PRODUCTO

Visitar nuestra página en Internet www.lifetime.com, o marcar al 1.800.225.3865 para registrar el producto hoy.

PARA RECLAMOS DE GARANTÍA INTERNACIONALES:

Todos los reclamos de garantía deben estar acompañados por un recibo de compra. Informar por escrito todos los reclamos de garantía a su representante regional de ventas. Favor de incluir el recibo de compra fechado y fotografías de las piezas dañadas.

Para identificar el representante regional, visitar www.lifetime.com/international



www.lifetime.com



GARANTIE DE FABRICATION LIMITÉE DE 10 ANS

LE FABRICANT SE RÉSERVE LE DROIT DE FAIRE DES SUBSTITUTIONS EN CAS DE RECOURS EN GARANTIE SI LES PIÈCES NE SONT PAS DISPONIBLES OU SONT OBSOLÈTES.

1. Les abris extérieurs Lifetime® sont garantis à l'acheteur d'origine contre tous défauts de matériau ou de fabrication pendant une durée de dix (10) ans à partir de la date d'achat d'origine. Le mot « défauts » signifie des défauts qui empêchent l'utilisation du produit. Les défauts résultant de mauvais usage, d'abus ou de négligence annulent cette garantie. Cette garantie ne couvre pas les dommages causés par le vandalisme, la rouille, « les catastrophes naturelles » ou tout autre événement en dehors du contrôle du fabricant.

2. Cette garantie n'est pas transférable et est expressément limitée à la réparation ou au remplacement du produit défectueux. Si le produit est déclaré défectueux selon les termes de cette garantie, Lifetime® Products, Inc. réparera ou remplacera les parties défectueuses gratuitement pour l'acheteur. Les frais d'expédition aller et retour de l'usine ne sont pas couverts et sont à la charge de l'acheteur. Les frais de main-d'œuvre et frais associés à l'enlèvement, au montage ou au remplacement de l'abri ou de ses composants ne sont pas couverts par cette garantie.

3. Cette garantie ne couvre pas les égratignures ou éraflures du produit résultant d'une utilisation normale. Par ailleurs, les défauts résultant de dommages intentionnels, négligence, utilisation abusive ou suspension à partir de l'entretoise annulent cette garantie.

4. Toute responsabilité pour dommages incidents ou consécutifs est exclue dans la mesure permise par la loi. Bien que toutes les mesures aient été prises pour intégrer le plus haut degré de sécurité dans l'ensemble du matériel, l'impossibilité de blessure ne peut pas être garantie. L'utilisateur assume tous les risques de blessure résultant de l'utilisation de ce produit. L'ensemble de la marchandise est vendu en vertu de cette condition et aucune personne représentant la société ne peut déroger à cette politique, ni la modifier.

5. Ce produit n'est pas prévu pour l'usage institutionnel ou commercial; Lifetime® Products, Inc. n'assume aucune responsabilité pour un tel usage. L'utilisation institutionnelle ou commerciale annulera cette garantie.

6. Nos articles sont offerts avec des garanties qui ne peuvent connaître d'exclusions en vertu de la loi australienne sur la protection des consommateurs. Vous avez droit au remplacement ou au remboursement en cas de défaillance majeure de votre article ainsi qu'à une compensation en cas de perte ou de dommage prévisible. Vous avez aussi droit à la réparation ou au remplacement de l'article s'il n'est pas d'une qualité acceptable et que la défaillance n'est pas majeure.

7. Cette garantie remplace expressément toutes les autres garanties, expresses ou tacites, y compris les garanties de commercialisation ou d'adaptation à un but particulier dans la mesure permise par les lois fédérales et des états. Ni Lifetime® Products, Inc. ni aucun de ses représentants n'assume d'autre responsabilité concernant ce produit. Cette garantie vous accorde des droits particuliers, et vous aurez peut-être d'autres droits qui varient d'un état à l'autre (ou d'une province à l'autre, selon le cas au Canada).

TOUS LES RECOURS EN GARANTIE DOIVENT ÊTRE ACCOMPAGNÉS DU REÇU DE VENTE.

FAIRE PARVENIR PAR ÉCRIT UN RAPPORT PAR ÉCRIT DE DÉFECTUOSITÉ DU PRODUIT A :

Lifetime Products, Inc., PO Box 160010 Clearfield, UT 84016-0010
ou composer 1.800.225.3865 lundi à vendredi 0700 - 1700 (HNR)

ENREGISTRER VOTRE ARTICLE À :

www.lifetime.com, ou composer 1.800.225.3865 pour enregistrer votre article aujourd'hui.

POUR RECOURS EN GARANTIE INTERNATIONAUX:

Tous les recours en garantie doivent être accompagnés du reçu de vente. Faire parvenir par écrit un rapport par écrit de défauts du produit au représentant régional de ventes. Veiller inclure votre reçu de vente daté et les photographies des pièces endommagées. Pour identifier le représentant régional, visiter www.lifetime.com/international



www.lifetime.com

ENHANCE YOUR LIFETIME® PURCHASE BY ADDING ACCESSORIES OR OTHER GREAT PRODUCTS

To purchase accessories or other Lifetime® products, visit us at:

www.lifetime.com

Or call: 1-800-424-3865

7:00 am–5:00 pm (M–F) MST and 9:00 am–1:00 pm Saturday MST

AMÉLIORER L'ACHAT LIFETIME® EN AJOUTANT DES ACCESSOIRES OU D'AUTRES PRODUITS

Pour acheter des accessoires ou des autres produits Lifetime®, visiter le :

www.lifetime.com

(Anglais seulement)

Ou composer le 1-800-424-3865

Du lundi au vendredi de 7 h à 17 h, HR et le samedi de 9 h à 13 h, HR

MEJORAR LA COMPRA DE LIFETIME® AGREGANDO ACCESORIOS U OTROS MARAVILLOSOS PRODUCTOS

Para comprar accesorios u otros productos de Lifetime®, visitarnos en:

www.lifetime.com

(solo inglés)

O marcar al: 1-800-424-3865

De lunes hasta viernes 7:00 h–17:00 h Horario Estándar de la Montaña (MST) y sábados 9:00 h–13:00 h (MST)



www.lifetime.com

