

## Positioning yourself

DON'T stick your face into the booth! Just get reasonably close. A good starting position is to lean in so your forehead just touches the top of the booth, and then move back a few inches. Your mouth - to - pop filter distance, should be approximately 7 to 10 inches. With experience you'll hear the 'sweet spot' that gives you the best sound. The Pro Booth's curved back wall and slanting top help shape and then dissipate the sonic energy created as your voice reaches the back wall reducing reflected sounds or "resonance."



In a noisy room use the lightweight – but effective – fleece audio hood located in the pouch on top of the booth. Drape it over your head and shoulders and attach it to the hook and loop contact patches on the sides of your booth.

## Positioning the script or sheet music:

For voice over work place the script inside the booth alongside the microphone. Clip it to the LED script clip light. Smart phones, tablets, ebook readers and solid state laptops work great and eliminate page turn noise reducing editing time! Singers and musicians may prefer to have sheet music outside the booth.

## Flying with your Pro

Since we introduced the Pro it's flown hundreds of thousands of miles on domestic and international flights as carry-on because of the allowance most airlines make for "odd-shaped" luggage like musical instruments and Porta-Booth Pros!

*Thanks for buying the Porta-Booth Pro a truly affordable and portable way to record studio quality audio – just about anywhere! It's a simple device - that simply – works. If you need other information, want to share a tip or have a compliment or concern please visit [Porta-Booth.com](http://Porta-Booth.com) for instructions and techniques on using your booth. Suitable microphones, accessories and other gear can be found at [VoiceOverEssentials.com](http://VoiceOverEssentials.com) or your favorite audio dealer.*

*Harlan Hogan*

### IMPORTANT INFORMATION

Although Auralex Studiofoam® is self-extinguishing other materials used in the construction of your Porta Booth Pro may be flammable. To reduce the risk of fire do not use near open flames.

#### One year Limited Warranty

Wordsworth, Inc. Warrants the Porta-Booth Pro against defects in materials and workmanship for a period of one year from the date of purchase. Visit [Porta-Booth.com](http://Porta-Booth.com) for details. To the extent permitted by local law, this warranty is in lieu of any other warranty, express or implied, including any implied warranty of merchantability or fitness and precludes any other obligation on the part of the manufacturer, distributor or dealer, including any liability for special, incidental or consequential damages.



# HARLAN HOGAN'S PORTA-BOOTH® PRO



**The professional – portable – sound booth for studio quality recording at home  
and on the road plus superior sound powered by Auralex Acoustics®!**

[www.Porta-Booth.com](http://www.Porta-Booth.com)

## Features

- Sonic stage auditorium design assembles in seconds
- All interior surfaces covered in Auralex Acoustics Studiofoam® the choice of recording professionals around the world
- Seven pound, rugged 600 denier fabric construction
- Multi-purpose rear & bottom slots for long microphones, stands and cables
- Boom-arm-lifter and anti-sway strap
- Fleece audio hood for noisy environments
- Almost twice as big as the Porta-Booth Pro
- Travel bag hold cables, gear and copy
- Optional Porta-Booth Stand®
- LED script clip light

### How the Porta-Booth Pro works

The secret is that YOU don't have to be inside a sound booth – your MICROPHONE does! Inside the Porta-Booth Pro your mic "hears" a quiet, acoustically correct room instead of the tell-tale "roomy-boomy" sound of an untreated recording space.

### What the Porta-Booth Pro does

Your booth shapes the sound your microphone picks up and also helps reduce extraneous noise. Position the booth away from windows and hallways and in tough locations – like hotel rooms – turn off the heat and/or air conditioning while you are recording and use the fleece audio hood.

### Assembling the Porta-Booth Pro

Caution! Your Porta-Booth Pro uses the highest-quality Auralex Studiofoam which will stay soft and intact for decades, but foam is fragile and can be easily torn. So zip and unzip carefully when putting together your booth.

### Assembles in less than two minutes!



**1.**  
*Open the carrying bag and remove*



**2.**  
*Zip the sides and bottom together.*



**3.**  
*Zip the top.*



**4.**  
*Use the four corner hook and loop strips to square up the booth and add extra rigidity.*



**5.**  
*Put the LED light into either of the two pouches inside the booth.*

### Using your Porta-Booth Pro®

For best results use a microphone with a cardioid (heart-shaped) pickup pattern like the MXL VO: 1-A with a pop screen approximately 3 inches in front of it.

Ideally, the mic should be placed dead center and 20% to 25% of the way back in the booth. If you use a long microphone, zip open the back wall slot and push the back end of the mic, cable and connector outside.

The Harlan Hogan 3 way adjustable universal desk stand is a good choice for home and on-the-road use. Carefully insert the base through the slit in the bottom foam so the stand sits on a solid surface rather than balanced on the foam.



You can set your booth on a desk, table, shelf or height adjustable music stand. The Voice-Over Essentials Porta-Sound® Stand works perfectly with your pro - sitting or standing and includes a second shelf for your recording equipment.

You can also 'hang' your Porta-Booth Pro on a boom arm microphone stand. Insert the boom arm through the rear wall zippered slot at a slight upward angle, closing the zipper and fastening the hook and loop anti-sway strap around the mic stand.

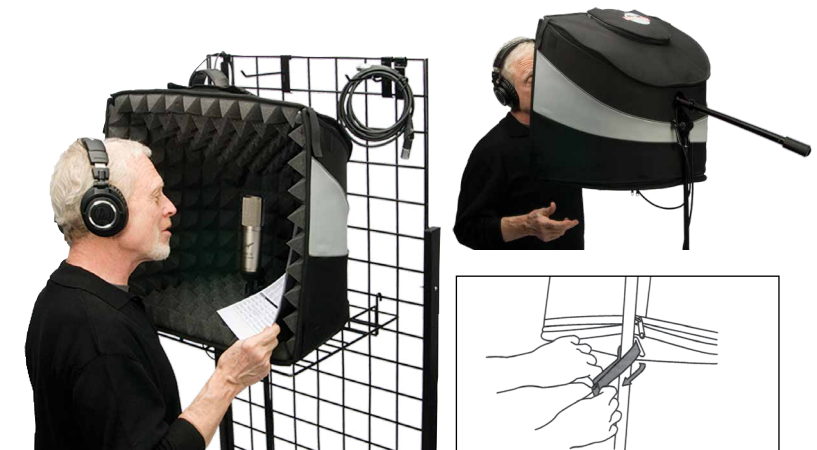

1. Zip open the bottom slot and insert the booth lifter strap pulling upward until the oval base is against the booth's bottom – then close the zipper.
2. Open the buckle and loop the strap around the boom arm and close the buckle.
3. Gently pull downward on the free end of the lifting strap while holding the boom arm steady and the booth will elevate several inches allowing room for the microphone connector.

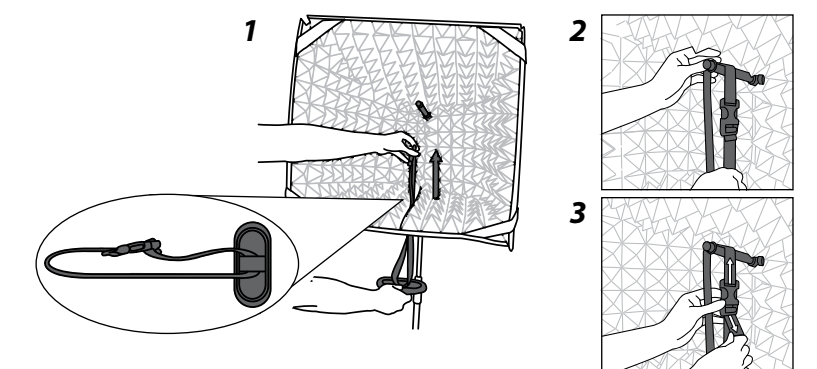

We recommend using an ABS —“Adjustable Boom Stop” — with all microphones and Porta-Booths. It's an inexpensive way to keep the boom from slipping or sagging, and potentially damaging your equipment.

[www.Porta-Booth.com](http://www.Porta-Booth.com)

