

marie[♥]-chantal

Silver Cross

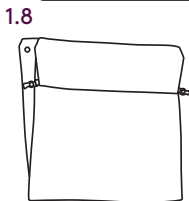
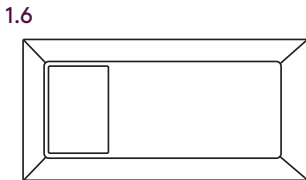
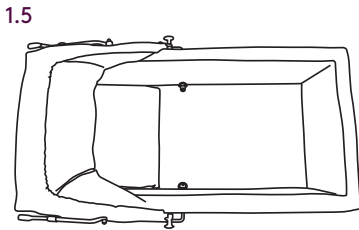
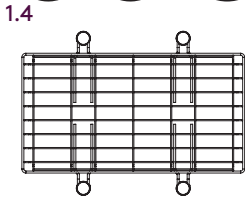
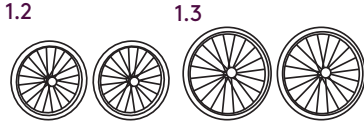
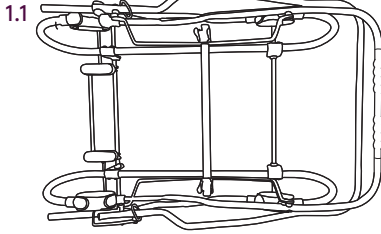

IMPORTANT: KEEP THESE INSTRUCTIONS FOR FUTURE REFERENCE

These instructions are important.

Contents

First check all your parts have been supplied. Your chassis and wheels are packaged in 1 box. Your body will be packaged in a second box.

Your Kensington chassis box includes:

- 1.1 Kensington chassis
- 1.2 2 x front wheels
- 1.3 2 x back wheels
- 1.4 Shopping tray

Your Kensington body box includes;

- 1.5 Kensington body
- 1.6 Liner
- 1.7 Mattress with cover
- 1.8 Apron

2.1

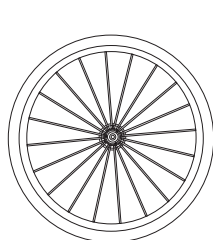
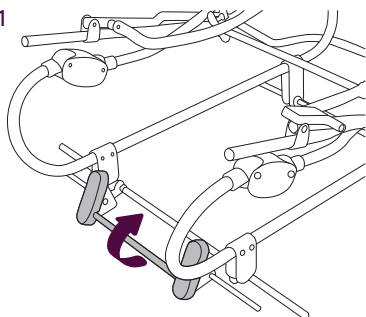

Front wheel

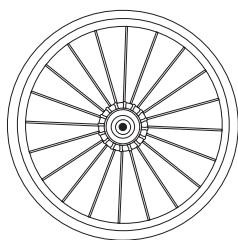

Rear wheel

Fitting the wheels

- 2.1 Ensure the brake is in the off position. Lift the brake pedal upwards to put it into the off position. Never push it downwards or force the brake as this will snap the brake.
- 2.2 Attach the wheels by tilting the chassis onto its side. The smaller wheel fits at the front of the chassis.
- 2.3 Pull the metal tab on the wheel out towards the tyre, and slide the wheel onto the axle.
- 2.4 Repeat the same action to attach the larger wheels onto the the rear axle, then do the same on the other side of the chassis.

2.2

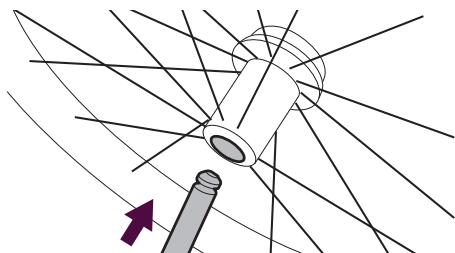

2.3

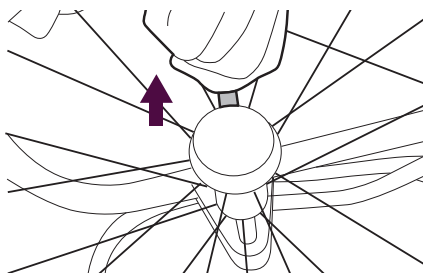

2.4

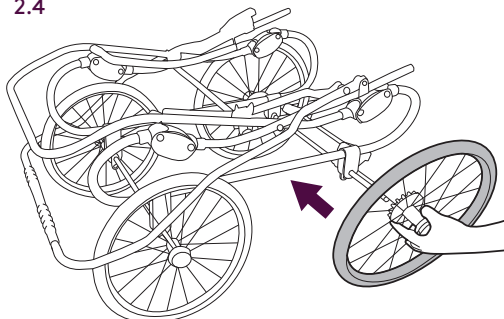

3.1

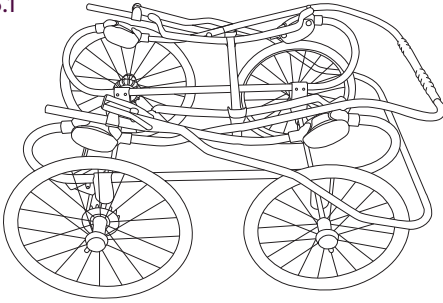

Unfolding the chassis

3.1 Stand the chassis on its wheels.

3.2 Ensure that the metal locking ring is clear of the secondary safety catch.

3.3 Pull the handle upwards towards you.

3.4 The secondary safety catch will automatically engage. Then slide the metal locking rings down the handle to securely erect the chassis.

3.2

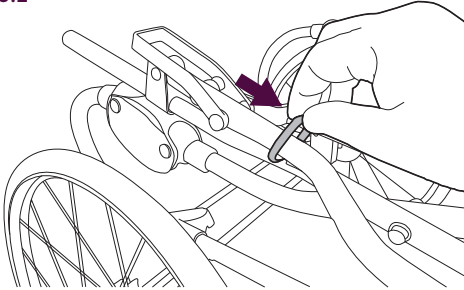

3.3

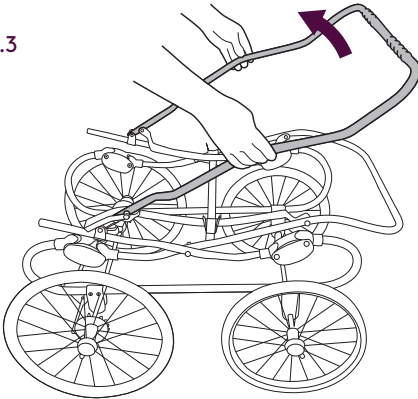

3.4

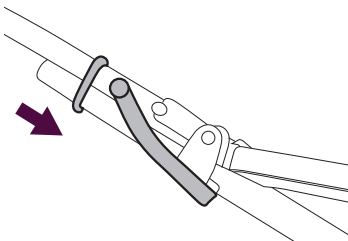

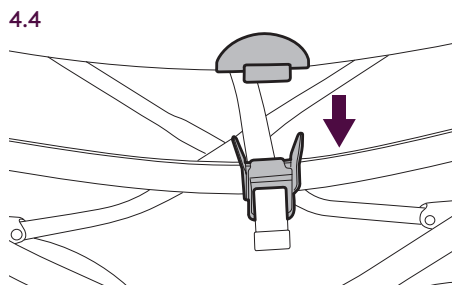
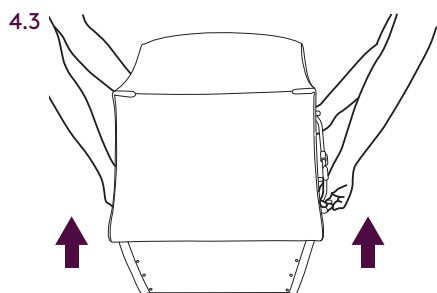
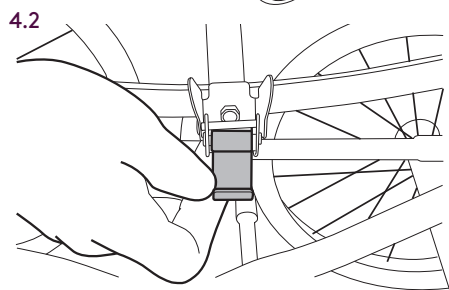
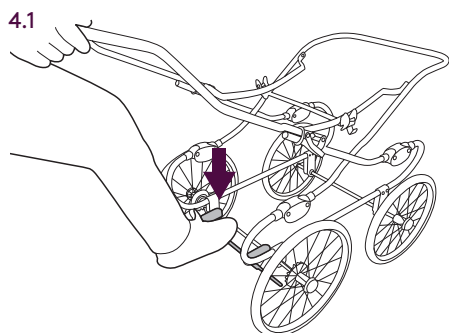

Attaching the pram body to the chassis

Never try to attach the body of the pram to the chassis with the child inside. It is recommended that two people lift the pram into position.

- 4.1 Before attaching the body, apply the brake.
- 4.2 Check that metal body locks are in the unlocked position.
- 4.3 It is best for two people to fit the body. Lift the body by the lifting handles.
- 4.4 Lower the body gently and carefully onto the chassis, ensuring the body locates into the metal body locks on both sides.
- 4.5 Lock the metal clips by the lifting them up and then pushing downwards.

Note: Always check both sides are securely fastened

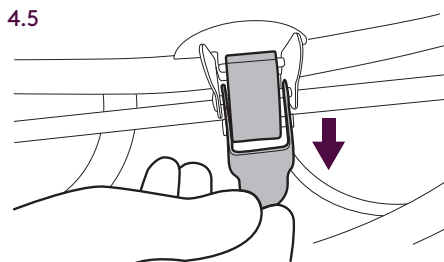

5.1

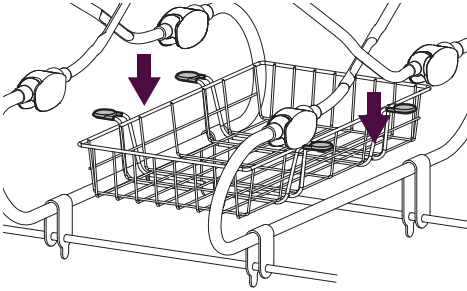

Attaching the tray

- 5.1 To fit the tray, hold in between the two 'C' frames, evenly positioned between the 'U' brackets. Lower onto the 'C' frame and click into place.

Note: Do not place items, bags of shopping for example, in the pram unit as it will cause it to become unstable.

6.1

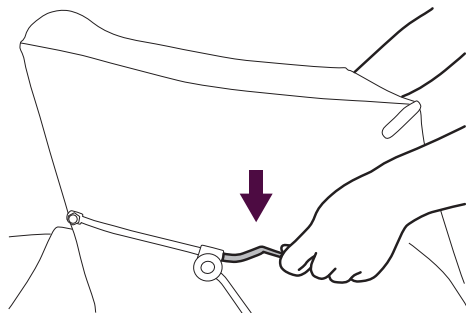

The hood and apron

CAUTION: The child should be clear of moving parts while making adjustments.

- 6.1 Lift hood into position and push down on the levers on both sides of the hood to secure in place.
- 6.2 Fit the apron around the contour of the pram body and fasten the press studs on either side of the pram. To hold the storm flap in place, loop the metal fastener over the nut on either side of the hood.

6.2

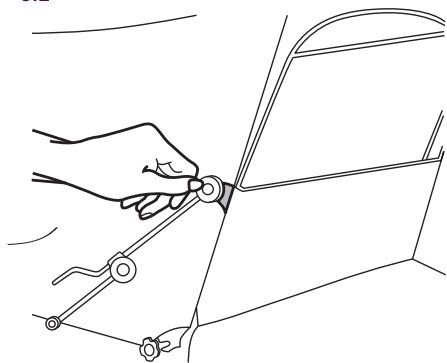

Note: The apron can still be used in conjunction with the liner.

Using the brake

- 7.1 To operate the brake push down on the pedal with your foot.
- 7.2 To release the brake lift up the pedal with your foot.

Note: Always apply the brake when the pram is stationary.

7.1

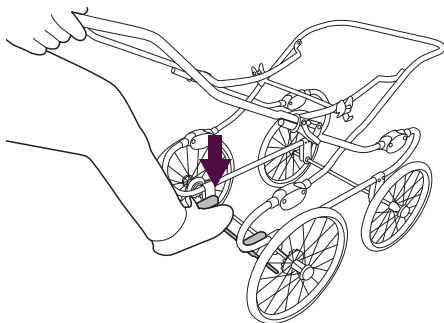

7.2

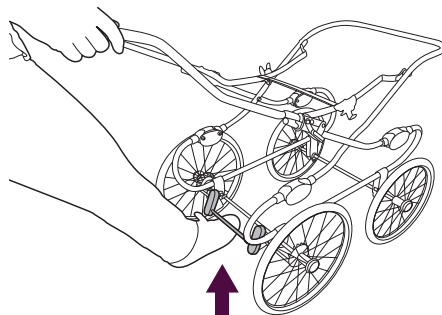

8.2

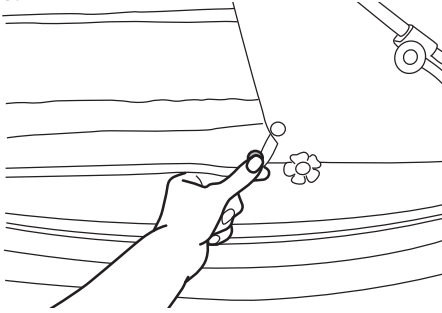

8.3

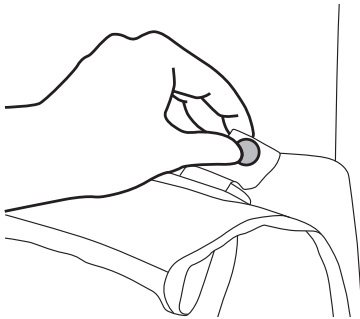

8.4



8.5

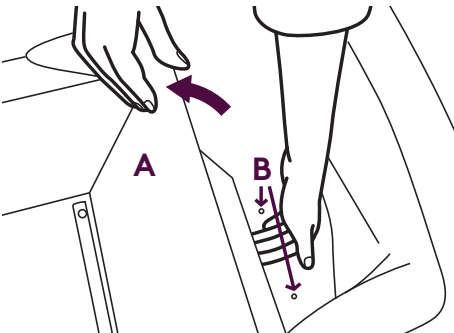

Using the liner and mattress

- 8.1 Ensure the hood is in the up position. Ensure the liner is the correct way up with the elasticated corners at the bottom of the pram body.
- 8.2 Secure the press studs which are half way up the liner to the press studs that are near the wing nut on both sides.
- 8.3 Secure the press studs that are attached to the elastic on the liner to the press studs that are built into the pram body on top of the back ledge.
- 8.4 The D-rings are accessible through the holes of the liner.

The mattress can be used with or without the liner. If using the mattress with the liner ensure the liner is in place first.
- 8.5 The support board "A" may be fixed in either a flat or angled position. Always check that the support board is placed firmly against the stops "B".

Note: Ensure the head rest part of the mattress is nearest the hood.

For advice on cleaning see the wash care label.

9.2

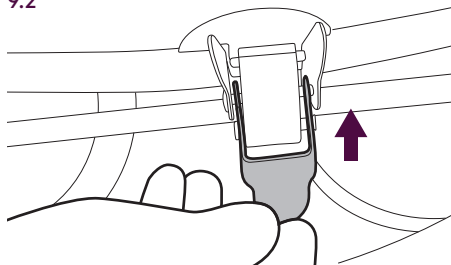

9.3

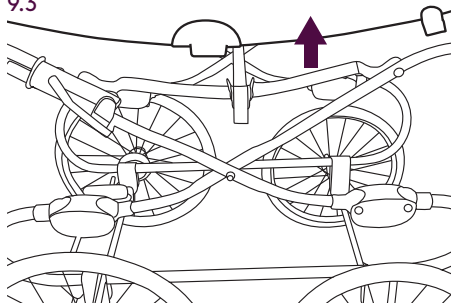

9.4

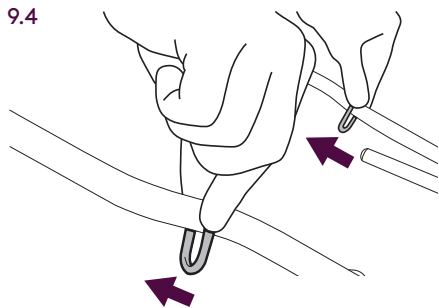

9.5

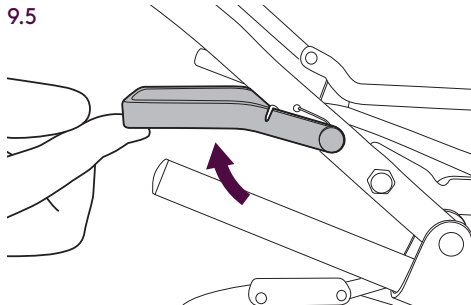

Folding the chassis

9.1 Firstly remove the pram body from the chassis.

Note: never attempt to do this with the child in the pram body, or on your own.

9.2 Release the catch on either side of the pram.

9.3 Lift the body, gently, by the lifting handles, clear of the chassis.

9.4 Slide the metal rings up the handle of the chassis.

9.5 Pull back the secondary safety catch, and allow the handle to travel forwards until it rests on the chassis.

9.6 To fold smaller the wheels can be removed by pulling the tab and sliding the wheel off the chassis.

9.6

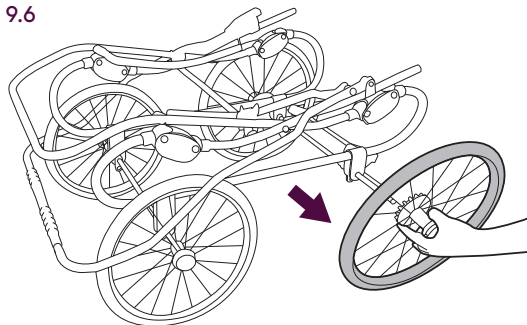

WARNINGS:

REMOVE ALL PACKAGING AND TIES BEFORE USE. CHECK YOUR KENSINGTON PRAM REGULARLY FOR SIGNS OF DAMAGE DURING USE AND DISCONTINUE USE IF FOUND.

KEEP AWAY FROM FIRE.

THIS PRODUCT IS NOT SUITABLE FOR RUNNING OR SKATING.

DO NOT CARRY MORE THAN ONE CHILD IN THIS PRAM. YOU SHOULD NEVER CARRY ANOTHER CHILD IN A SEAT ON TOP OF THIS PRAM.

NEVER LEAVE YOUR CHILD UNATTENDED.

ENSURE THAT ALL LOCKING DEVICES ARE ENGAGED BEFORE USE.

DO NOT LET YOUR CHILD PLAY WITH THIS PRODUCT.

TO AVOID INJURY ENSURE THAT YOUR CHILD IS KEPT AWAY WHEN FOLDING AND UNFOLDING THIS PRODUCT.

CHECK THAT THE PRAM BODY ATTACHMENT DEVICES ARE CORRECTLY ENGAGED BEFORE USE.

ONLY USE THE MATTRESS PROVIDED BY SILVER CROSS. NO ADDITIONAL MATTRESS SHOULD BE USED.

DO NOT USE ANY OTHER ACCESSORIES OTHER THAN THOSE SUPPLIED BY SILVER CROSS.

THIS PRODUCT CONFORMS TO APPLICABLE SAFETY STANDARDS OF BS EN 1888:2012 (WITH THE EXEMPTION OF CLAUSES 8.10.3, 8.10.4, 8.10.6)

IT IS RECOMMENDED THAT THE MOST RECLINED POSITION IS USED FOR NEW BORN BABIES.

THE PARKING DEVICE SHOULD BE FULLY ENGAGED WHEN REPLACING AND REMOVING CHILDREN.

ANY LOAD ATTACHED TO THE HANDLE AFFECTS THE STABILITY OF THE PRAM. THE ADDITIONAL SILVER CROSS CHANGING BAG AVAILABLE FOR PURCHASE MUST NOT EXCEED A LOAD OF 1KG WHEN ATTACHED TO THE PRAM.

THE CONTENTS OF THE BASKET SHOULD NOT EXCEED 5KG IN WEIGHT AND SHOULD BE EVENLY DISTRIBUTED.

THIS PRODUCT IS SUITABLE FOR A CHILD WHO CANNOT SIT UP BY ITESLFF, ROLL OVER, AND CANNOT PUSH ITSELF UP ON ITS HANDS AND KNEES.

THE KENSINGTON CHASSIS IS COMPATIBLE WITH THE KENSINGTON BODY ONLY.

MAXIMUM WEIGHT OF CHILD: 9KG

Safety Notes

Your Kensington Pram is a high quality Silver Cross product. This product conforms to applicable safety standards of BSEN1888:2012 (with the exemption of clauses 8.10.3, 8.10.4, 8.10.6) and with correct use and maintenance should give good service.

If however you should have any problems with your Kensington Pram, please contact your Silver Cross retailer who will take appropriate action.

This pram is intended to be used from birth up to 6 months.

If somebody unfamiliar is using your pram always ensure that they read these instructions carefully so that they understand how the product works best.

Always read all the instructions provided carefully and remember, the safety of your child is your responsibility.

Guarantee

All Silver Cross products are guaranteed for a period of twelve months against manufacturing faults. However please refer to the extended guarantee details included with the certificate of authenticity to register for your free 5 year guarantee.

Please read these instructions carefully before using your new Kensington Pram and keep for future reference.

Handmade in England.

Additional accessories include:

- Sun Canopy
- Bedding Set
- Dust Cover
- Rain Shield
- Changing bag

www.silvercrossbaby.com

0345 872 6900

Spares

A full range of spares for the entire Classic Collection product range by Silver Cross is available from www.heritage-prams.co.uk

Only replacement parts supplied or recommended by the manufacturer should be used.

Silver Cross®

THE BEST START IN LIFE

Silver Cross (UK) Ltd, Micklethorn, Broughton, Skipton, North Yorkshire, BD23 3JA

silvercrossbaby.com