

# PET Felt panels

## V-cut



### **Installation options**

The V-cut panels provide a simple and efficient method to create a patterned wall design. These pre-designed panels are tileable and ready-to-use. You can easily install them using adhesive or brad nails, depending on the wall lining and project requirements.

### **Handling**

The PET Felt panels should be handled carefully during transportation and unloading. Please carry vertically. This is necessary to avoid the deformation of the material.

### **Colours**

Slight color deviations may occur since the ReFelt panels are made from recycled fibers. It is recommended to use the same batch per project. When placing an order, please, take a margin into account for unforeseen changes or additions to a design plan.

### **Before installation**

We would like to emphasize that it is important to carefully check the entire order before processing or installing the panels.

Keep in mind to apply the panels in the same direction to avoid alterations in appearance.

## Adhesive

---

When installing PET Felt panels, it is advisable to use a polymer adhesive like Griffon poly max high tack. This SMP sealant is available at most hardware stores. Please, read the manufacturer's instructions before the installation. The advantage of a polymer glue is that you can apply it on large areas and still correct the placement since the adhesive does not dry immediately.

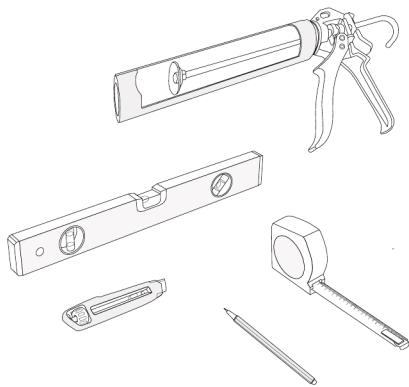

Suggested tools

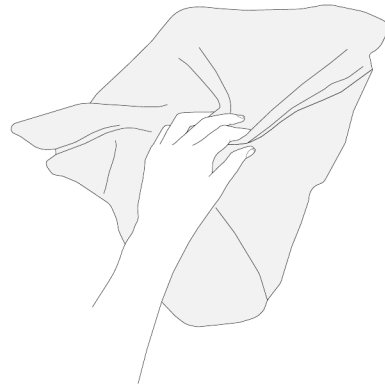

①

### Prepare the surface

Ensure that the surface is flat and clean.

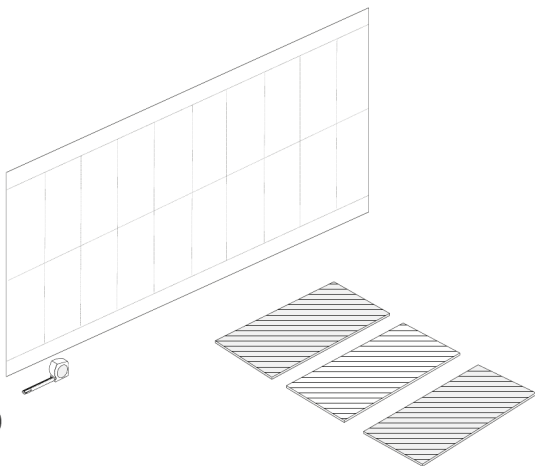

②

### Arrange

If you want to make a pattern, we advise to arrange it on the floor first.

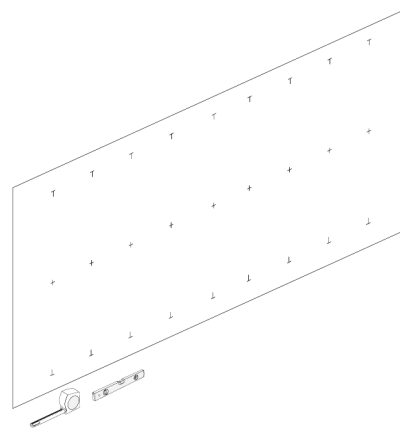

③

### Mark out

It may be useful to put a number of reference markings on the wall indicating the final alignment of the panels.

## Adhesive

---

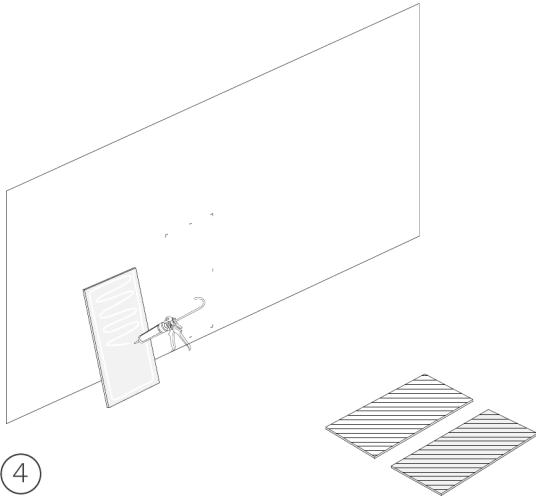

④

### Apply glue

Apply the adhesive on the panel, following the manufacturer's instructions. Distribute it evenly.

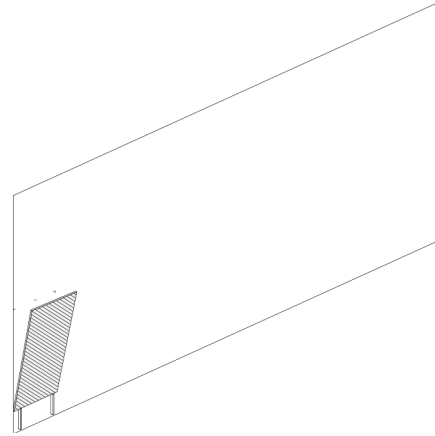

⑤

### Place panel

Start mounting the panel from the bottom. It can be helpful to use spacers to ensure a leveled placement.

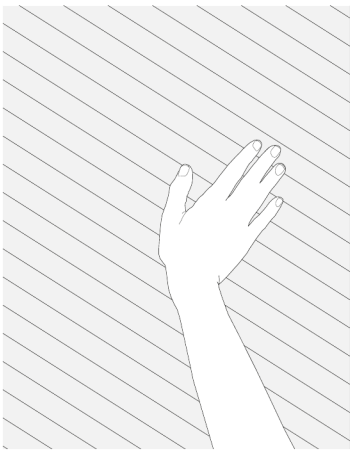

⑥

### Press

Press the panel firmly against the surface, make sure that the corners and edges are properly attached.

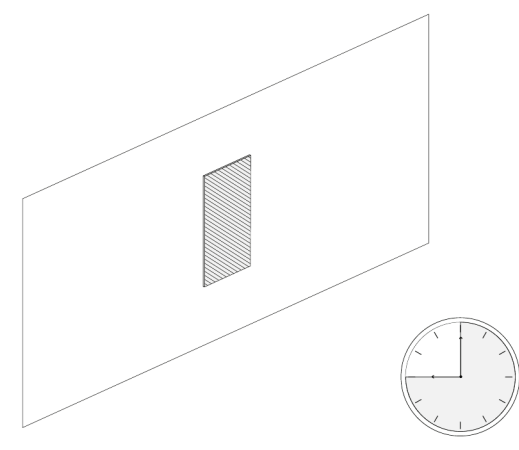

⑦

### Cure Time

Allow the adhesive to cure. The curing time may vary, follow the adhesive manufacturer's recommendations.

## Brad nails

Brad nails can be applied using a brad nailer, an equivalent pneumatic or cordless nailer tool. Using a brad nailer is the quickest way to install the PET Felt panels. The nails will not be apparent because they disappear between the fibers. However, if you look closely, small holes will still be visible.

⚠ It is not necessary to use additional adhesive in combination with the brad nails. This method also makes it easy to dismantle the panels.

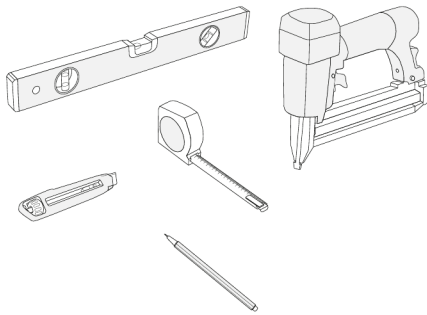

### Suggested tools

This installation method can be applied on any surface that is suitable for brad nails.

①

### Framework

Prepare a wooden framework and make sure the frame is leveled. Choose the grid suitable for the size of panels.

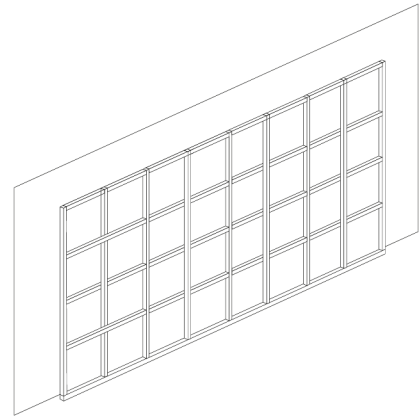

②

### Apply panels

The pressure of a pneumatic nailer tool must be set to approximately 5.0 to 5.5 bar.

③

### Angle

For a better grip of the headless nail, the nails can be applied at an angle of approximately 45°.

