

WHISPERFLO®

HIGH PERFORMANCE PUMPS



FEATURED HIGHLIGHTS:

- Unique FunnelFlo™ diffuser and high-efficiency impeller maximise water flow and energy efficiency whilst minimising turbulence and noise.
- Specially engineered design assures whisper-quiet operation.
- Oversized strainer basket and volute extends time between cleaning.
- See-through lid makes inspection fast and easy and the engineered polymer will remain clear for years.
- Lower HP's deliver higher performance than industry standard.
- Compatible with all cleaning systems, various filters and jet action spas.
- Heavy-duty/durable construction is designed for long life.
- Designed for residential and commercial applications.
- User friendly Cam & Ramp™ lid is easy to remove and quickly locks in place with a quarter turn.
- 50mm /2" barrel unions included.
- 3 years limited warranty.*

We call it the WhisperFlo pump for good reasons. The innovative hydraulic design moves water more efficiently and more quietly than conventional pumps. Our legendary hydraulic design has been refined over 40 years for superior performance. Under typical operating conditions, WhisperFlo delivers high water flow with low electrical consumption.

WhisperFlo is designed to be a tireless workhorse, its engineered thermoplastic housing withstands extreme heat and resists corrosion. The commercial grade motor has a rust-resistant, stainless steel shaft and sealed bearings that never need lubrication. Engineered to provide optimum performance in any size pool and spa combination.

ORDERING INFORMATION

Part	Model	Voltage (VAC)	Full Load (A)	Power Input (P1,W)	Power Output (P2,W)	Nominal Power (hp)	Locked Rotor Current (A)	Capacitor (uF)	Carton Dim(mm).	Carton Weight (Kg.)	Pallet Qty.
HIGH PERFORMANCE SINGLE PHASE											
WHFL-750-1P	WhisperFlo 750	230-240	3.8	890	670	1	14	25	725x325x390	15	12
WHFL-1100-1P	WhisperFlo 1100	230-240	5.5	1260	945	1.5	22	25	725x325x390	19.5	12
WHFL-1500-1P	WhisperFlo 1500	230-240	6.3	1490	1120	2	28	35	725x325x390	22	12
WHFL-2100-1P	WhisperFlo 2100	230-240	9.0*	2020	1610	3	42	2x25	725x325x390	27	12

*Terms and conditions apply

*WhisperFlo 2100 is equipped with a 15A plug

WHISPERFLO[®]

HIGH PERFORMANCE PUMPS

DIMENSIONS AND PERFORMANCE*

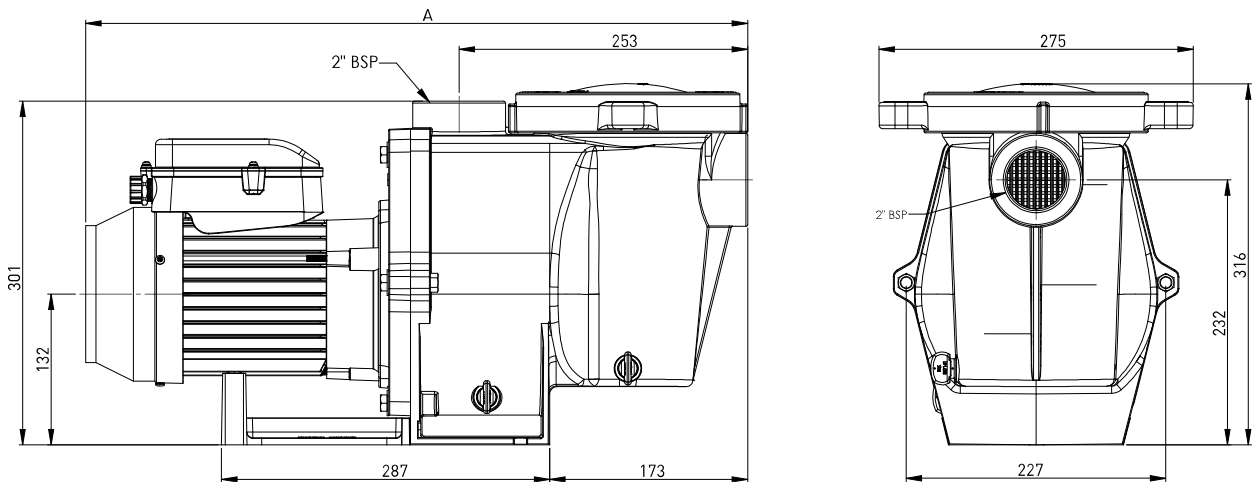
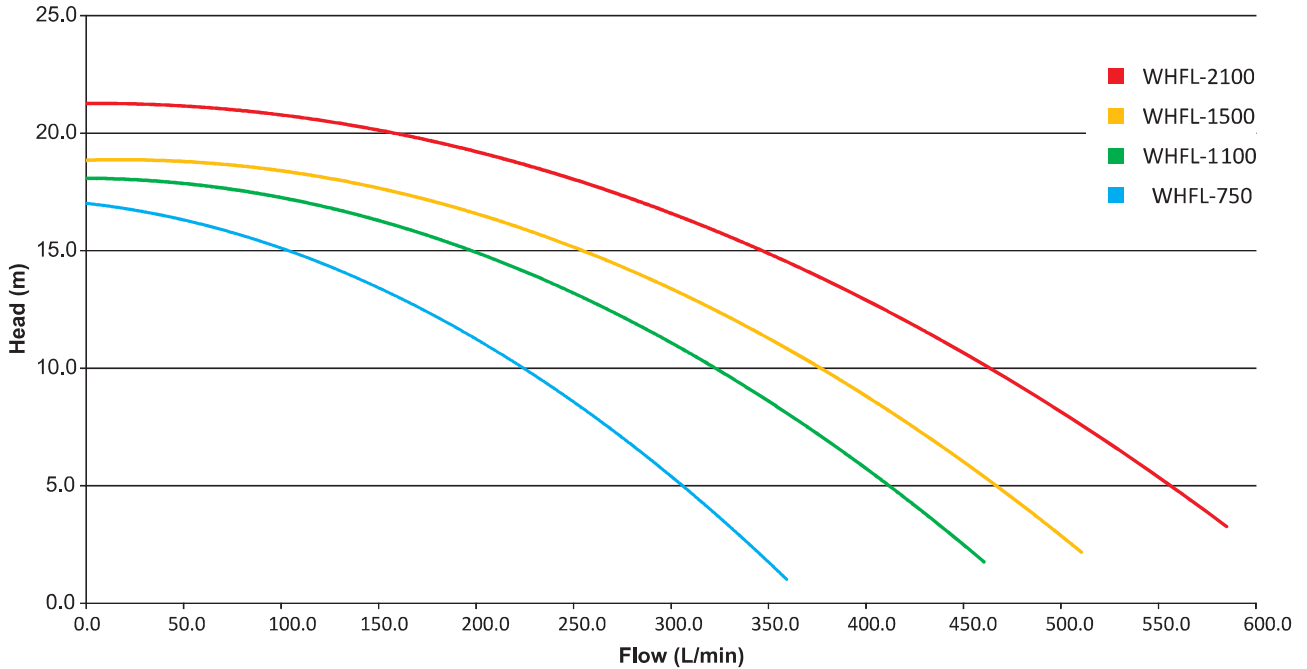

Pump Model	WHFL750	WHFL1100	WHFL1500	WHFL2100
A (mm)	570	580	620	620

*All dimensions in mm.
See pages 132-133 for replacement parts.