

## 15 SERIES

### CAST IRON WATER TRANSFER PUMPS CENTRIFUGAL PUMPS



#### FEATURES

- Cast iron external construction for strength and durability in the toughest conditions.
- Open designed impeller (150) and shroud type impeller (152) both with built-in check valve for excellent self priming characteristics.
- Handles soft solids without clogging.
- Max. Head - 18m.
- Max. flow - 375lpm.



#### APPLICATIONS

- Domestic, industrial or rural water transfer pump including grey water.
- Sump emptying.
- Effluent transfer.

#### PUMP INFORMATION

Horizontal, single-stage, surface mounted centrifugal pump with open impeller coupled to a cool running Totally Enclosed Fan Cooled 2 pole motor with external thermal overload (single phase only, three phase units require separate quick trip overload supplied by electrical contractor).

#### OPERATING CONDITIONS

Suitable for pumping clean, grey and effluent water.

Fluid:	Water
Maximum water temperature:	70°C
Minimum water temperature:	1°C
Maximum ambient temperature:	55°C

# 15 SERIES - Technical Data

## PERFORMANCE CURVE

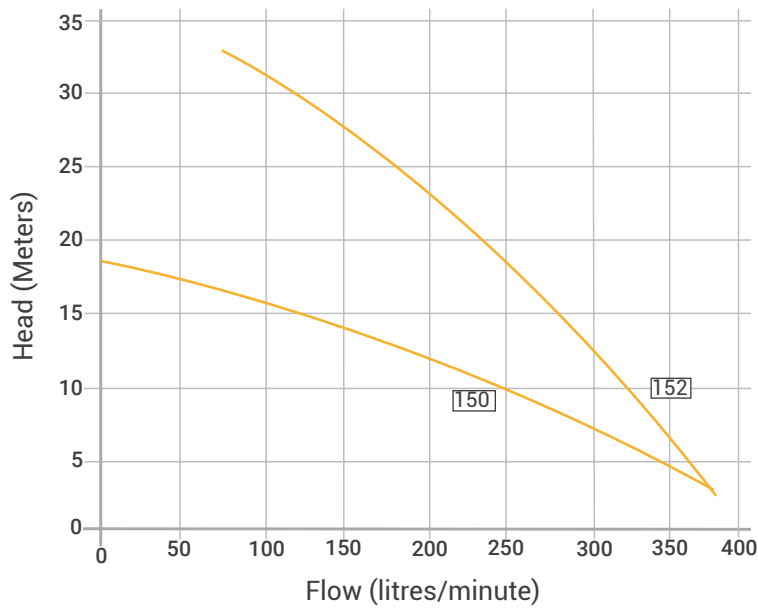

## PERFORMANCE

Type	P/No	Delivery head [m]	5	10	15	20	25	30
150	315000 (1 phase) / 315030 (3 phase)	Capacity [litre per minute]	341	249	128	-	-	-
152	315200 (1 phase) / 315230 (3 phase)		360	325	283	236	183	120

## ELECTRICAL DATA

Type	Type of current	Voltage ±10%	Frequency Hz	Motor rating kW P2	RPM	Current ampere	Locked rotor current	Motor protection	Insulation class	IP rating
150	1-phase	230	50	1.1	2900	10.8 A	38.8 A	Auto	B	IP44
150	3-phase	400	50	1.1	2900	3.3 A	23.6 A	-	B	IP44
152	1-phase	230	50	1.5	2900	10.8 A	38.8 A	Auto	B	IP44
152	3-phase	400	50	1.5	2900	3.3 A	23.6 A	-	B	IP44

DIMENSIONS				
Type	Inlet	Pump outlet	Carton L x W x H	Packed weight
150/1	2" BSP (male)	2" BSP (male)	560 x 350 x 440 mm	42 kg
150/3	2" BSP (male)	2" BSP (male)	560 x 350 x 460 mm	42 kg
152/1	2" BSP (male)	2" BSP (male)	560 x 350 x 440 mm	42 kg
152/3	2" BSP (male)	2" BSP (male)	560 x 350 x 460 mm	42 kg

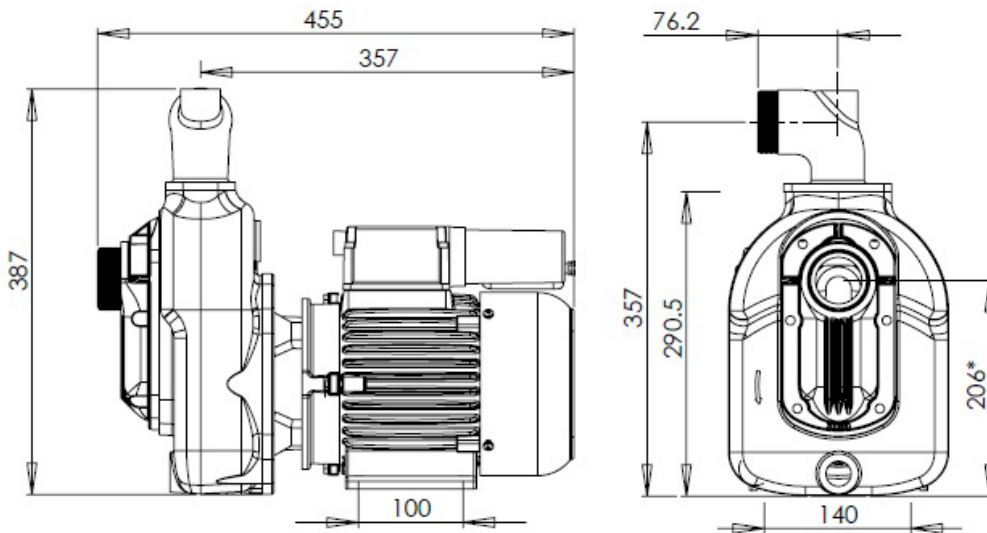

PUMP CONSTRUCTION MATERIALS		
Component	Material	
	150	152
Pump casing	Cast iron	
Baffle	20% Glass Filled Polycarbonate	20% Glass Filled Noryl
Priming cap	Acetyl	
Impeller	20% Glass Filled Polycarbonate	
Diffuser	20% Glass Filled modified Polyphenylene Oxide	20% Glass filled Noryl
Shaft sleeve	Acetyl	Nylon
Seal flexible bellows	Elastomer EPDM	
Seal stationary face	Ceramic	
Seal rotating face	Carbon	
Seal spring	304 Stainless Steel	
Motor shaft	Mild Steel	
O'Rings	Nitrile	