

JJ600 SERIES

JUNIOR JET FARMMASTER PUMP JET ASSISTED PRESSURE PUMP

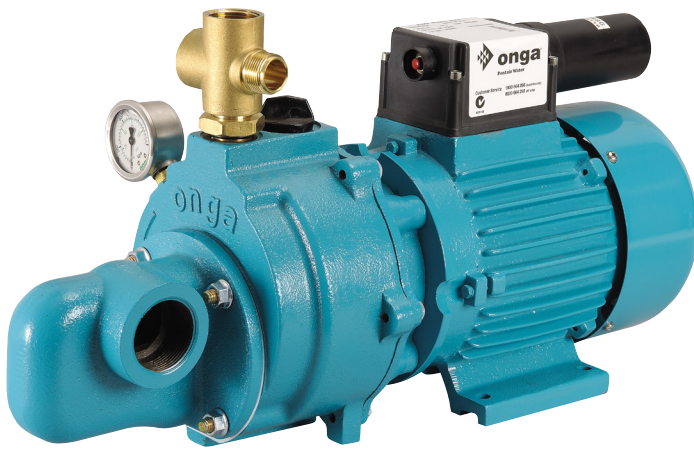

FEATURES

- Strong Cast Iron construction.
- Injectors to suit large range of applications.
- Offset combinations available.
- No moving parts down bore.
- Shallow well lifts to 7.6m
- Deep well lifts to 37m
- Manual or automatic system.
- Max. head - 63m.
- Max. flow - 137lpm.



APPLICATIONS

- Domestic, industrial or rural pressure pump for use as a manual or automatic pressure system.
- Stock watering, irrigation and water transfer.
- Option of a large range of water sources including tanks, bores, dams, creeks and rivers thanks to various injector combinations.

PUMP INFORMATION

Horizontal, single-stage, surface mounted centrifugal pump. Jet and venturi assisted performance with closed impeller for pumping debris free water. Cast iron injector housing and pump casing with 1 1/2" BSP (female) inlet and 3/4" BSP (female) outlet.

OPERATING CONDITIONS

Suitable for pumping clean non-aggressive liquids without solids or fibres in suspension.

Fluid:	Water
Maximum water temperature:	55°C
Minimum water temperature:	1°C
Maximum ambient temperature:	40°C

SCOPE OF SUPPLY

JJ600 pump and motor.
Pressure switch fitted.
Pressure gauge.

JJ600 SERIES - Technical Data

ELECTRICAL DATA

Type	Type of current	Voltage ± 10%	Frequency Hz	Motor rating kW		Normal RPM	Current ampere	Locked rotor current	Motor protection	Insulation class	IP rating
				P1	P2						
JJ600	1-phase	230	50	1.4	1.1	2900	6.4 A	42 A	Auto	B	44
JJ600	3-phase	400	50	1.5	1.1	2900	2.6 A	27 A	-	B	44

PERFORMANCE

Type	Injector model	Pressure switch setting (kPa)	Suction depth (m)	Total head in metres						Maximum pump pressure (kPa)
				15	21	27	34	40	46	
				Capacity (litres per minute)						
JJ600	S600	140-280*	0	137	112	71	24			375
			3	109	89	57			345	
			6	78	64	40			315	
			7.6	55	45	28			300	
	S601	210-350#	0	125	112	74	33		410	
			3	100	89	59	26		380	
			6	71	64	42			350	
			7.6	50	45	29			335	
	S602	280-420*	0		100	82	51	29		505
			3		80	66	41	23		475
			6		57	47	29	16		445
			7.6		40	33	20	12		440
	S603	350-560*	0			62	48	34	22	615
			3			50	38	27	18	585
			6			35	27	19	12	555
			7.6			25	19	14	9	540

PERFORMANCE CURVE

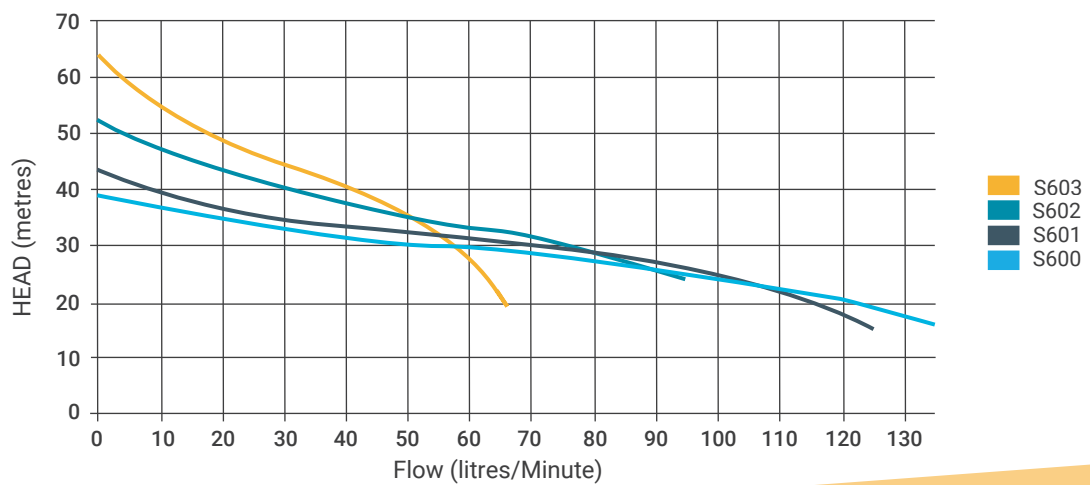

JJ600 SERIES- Technical Data

PUMP CONSTRUCTION MATERIALS

Component	Material
Pump casing	Cast iron
Casing spigot	N/A
Baffle	Noryl
Priming / drain plug	Acetal
Impeller	Polycarb 20% glass filled
Diffuser	Noryl
Shaft sleeve	Nylon
Seal flexible bellows	Elastomer EPDM
Seal stationary face	Ceramic
Seal rotating face	Resin impregnated carbon graphite
Seal spring	304 stainless steel
Motor shaft	Mild steel

DIMENSIONS

Type	Maximum L x W x H	Weight approx	Inlet	Pump outlet	Pressure kit outlet	Carton L x W x H	Packed weight
JJ600 (1-phase)	555 x 220 x 285 mm	31 kg	1 1/2" BSP (female)	3/4" BSP (female)	1" BSP (female)	590 x 300 x 330 mm	33 kg
JJ600 (3-phase)	560 x 220 x 285 mm	31 kg	1 1/2" BSP (female)	3/4" BSP (female)	1" BSP (female)	590 x 300 x 330 mm	33 kg

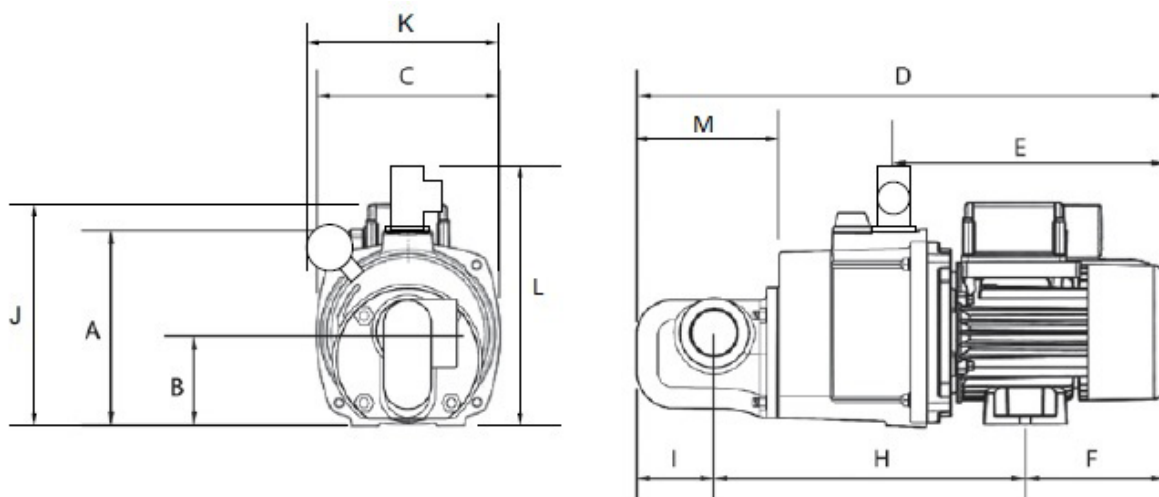

Type	A	B	C	D	E	F	H	I	J	K	L	M
JJ600 (1-phase)	210	15	210	540	335	110	350	80	265	220	285	135
JJ600 (3-phase)	210	105	210	560	350	125	355	80	245	220	285	135